



US 20020189183A1

(19) **United States**

(12) **Patent Application Publication**
Ricciardelli

(10) **Pub. No.: US 2002/0189183 A1**

(43) **Pub. Date: Dec. 19, 2002**

(54) **DECORATIVE INTERLOCKING TILE**

(52) **U.S. Cl.** **52/390**; 52/392; 52/389; 52/384;
52/313; 52/311.1; 52/311.2;
52/581; 52/588.1

(76) Inventor: **Thomas E. Ricciardelli**, Hingham, MA
(US)

Correspondence Address:

Jerry M. Presson
95 Golden Hill Road
Trumbull, CT 06611 (US)

(57) **ABSTRACT**

(21) Appl. No.: **09/884,638**

(22) Filed: **Jun. 19, 2001**

Publication Classification

(51) **Int. Cl.⁷** **E04F 15/00**; E04F 13/00;
E04F 13/08

A polymeric floor tile of elongated shape having a top surface molded to simulate a section of wood flooring with a plurality of staggered boards. The tile is adhesive-free, made possible by novel mating interlocks formed so as to lie below the linear edges defining the top tile surface. A decorative layer of wood grain may be applied to the top surface during or after molding to enhance simulation.

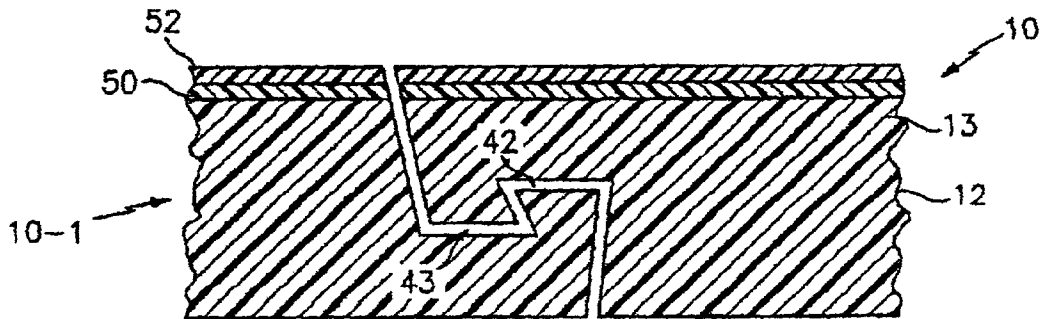

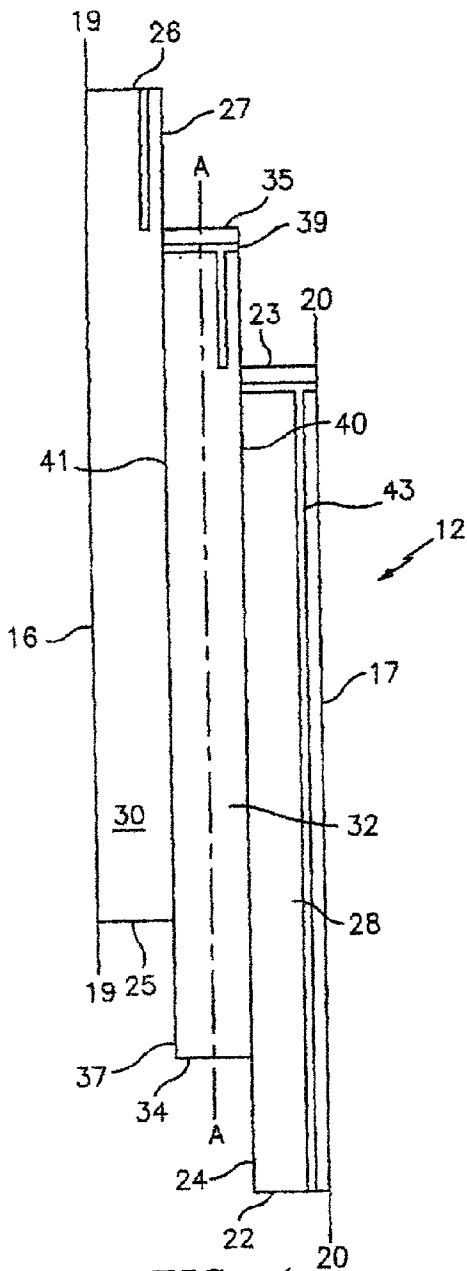

FIG. 1

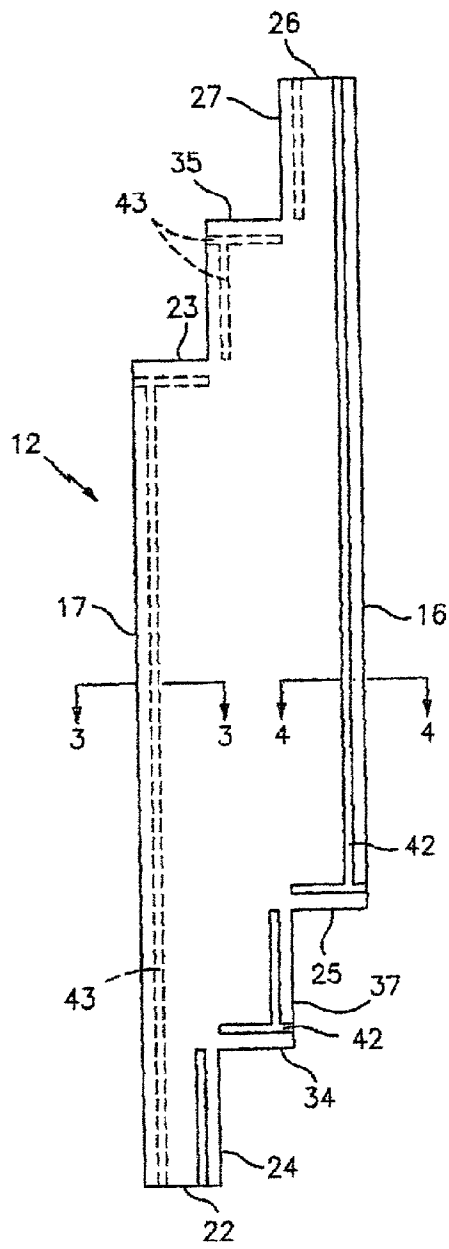

FIG. 2

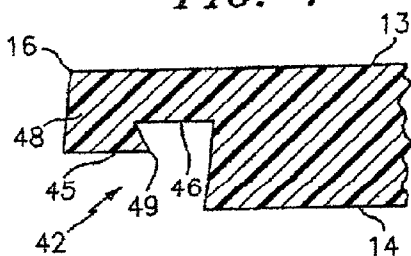

FIG. 3

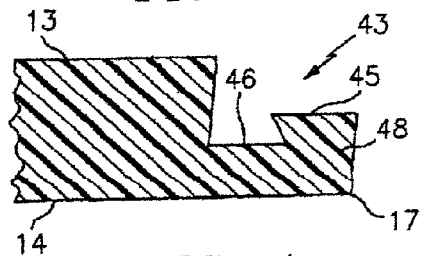

FIG. 4

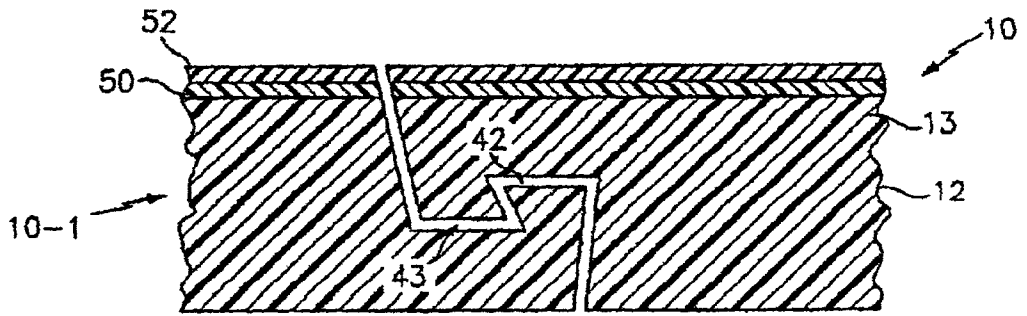

FIG. 5

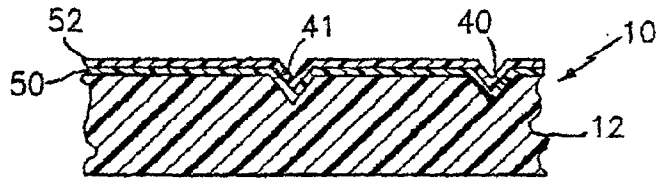

FIG. 6

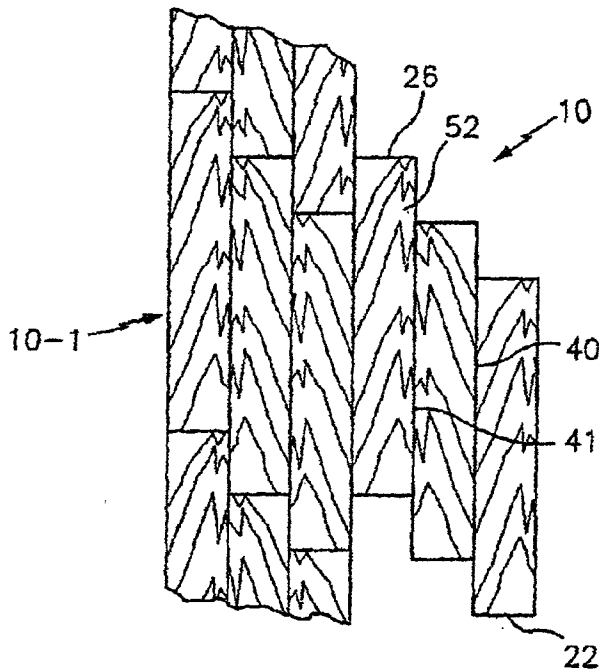

FIG. 7

DECORATIVE INTERLOCKING TILE

SUMMARY OF THE INVENTION

BACKGROUND

[0001] 1. Field of Invention

[0002] The present invention relates to a polymeric floor tile having interlock structures that interlock with similar tiles having similar interlock structures for providing an adhesive-free floor surface covering. More particularly, this invention relates to a polymeric floor tile with a wood-grained decorative surface. The tile is constructed to simulate a section of a wood floor and has border interlocks that engage the borders of adjacent tiles in a staggered relationship to simulate additional surfaces of the floor.

[0003] 2. Background Art

[0004] A floor tile molded from a polymeric material and having interlocking edge structures used in an adhesive-free floor installation is disclosed in co-pending U.S. patent application Ser. No. 09/152,684, filed Sep. 14, 1998, and assigned to the same assignee as the present invention. That application is hereby incorporated by reference in its entirety herein.

[0005] Interlocks are molded into the edges of a tile during the molding process and are designed as alternating T-shaped male tabs and interlocking T-shaped female slots of slightly larger size that can mate with similar T-shaped tabs of other tiles. Male and female interlocks of substantially the same respective dimensions and shapes enable the female and male interlocks of two or more abutting tiles to be locked together by vertically aligning the T-shaped male tabs of an interlock of one tile over the female inverted T-shaped slots of an underlying tile and then driving the male tabs into the underlying female slots, using, for instance, a mallet or hammer.

[0006] Floor tiles of the interlocking type are generally of square shape and because the interlocks alternate between a male interlock and a female interlock, and define the outer edges of the tile, the tile edges are characterized by a succession of outwardly projecting male tab portions and inwardly inverted female portions. When two tiles are assembled as described, the succession of alternating T-shaped inverted edges of abutting tiles is unattractive as well as unacceptable for installations where surface appearance is important.

[0007] Certain applications, particularly applications requiring that the tile have a decorative layer on its top surface require linear edges for desired surface appearance. Because the interlocks are typically formed on the border edges of the tile base during the molding process, the application of a decorative layer to the tile base during an extrusion process might adversely affect the subsequent functionality of the interlocks by, for example, extruding into the open ends of the female slots because the slots are in the same plan as the top tile surface.

[0008] Therefore, what is needed to overcome limitations of conventional floor tiles is an adhesive-free floor tile assembly with an interlock system that does not adversely affect the appearance of the tile assembly and appears to have substantially linear border edges. Such a system would permit the top tile surface to have a desired decorative design and appearance.

[0009] The present invention relates to a polymeric floor tile of the adhesive-free type, wherein there are interlock structures on the tile, which are concealed after the tile is installed in an interlock assembly with similar tiles, thereby providing the tile edges with a linear edge appearance. The linear tile edges are useful in providing the tile with an appropriately decorated top layer to simulate certain rectangular floor constructions, such as wood floors with longitudinally staggered wooden floorboards or ceramic tile with grout therebetween. Advantageously, a decorative layer may be adhered to the tile base during an extrusion process whereby the tile, as extruded, is appropriately decorated.

[0010] Accordingly, one embodiment of the present invention is directed to a floor tile that has a flat, elongated base having a top surface, a bottom surface and distal and proximal ends. First and second opposite sides lie in respective first and second substantially parallel side planes. A longitudinal axis is disposed between and substantially parallel to the side planes. One or more stepped edges are formed on the distal and proximal ends. The stepped edges are formed by adjoining longitudinal and transverse edge portions. The longitudinal edge portion of an edge is in a longitudinal plane inward of one of the side planes and extends substantially parallel thereto.

[0011] Another embodiment of the present invention is directed to an elongated polymeric tile with interlock structures and staggered ends for mating with similar structures of abutting rectangular tiles.

[0012] Yet another embodiment of the present invention is directed to a hermaphroditic interlock structure, which is especially useful in interlocking abutting, elongated polymeric tiles of similar size and shape in a surface-covering tile assembly.

[0013] Yet another embodiment is directed to a floor tile assembly that includes a plurality of mutually adjacent tiles mechanically interlocked along the sides thereof for adhesive-free mounting to a surface. Each of the tiles has an elongated base of substantially rectangular cross-section having a longitudinal axis, a top and bottom surface and first and second substantially linear peripheral edges that form substantially straight borders. A pair of open-sided interlock structures are molded in the base extending parallel to and adjacent to the first and second edges. The open side of an interlock structure adjacent the first side edge facing the bottom surface engages a mating interlock structure adjacent the second side edge facing the top surface. A plurality of transverse stepped end surfaces are formed on opposite ends of the base.

[0014] Yet another embodiment is directed to a floor tile molded of polymeric material, including a plurality of flat, elongated tile sections of substantially equal length. Each of the plurality of tile sections has adjoining top surfaces of generally rectangular shape. The plurality of tile sections are joined in a parallel longitudinally staggered relationship to simulate the staggering of abutting elongated boards in a wooden floor installation. A decorative layer on the top surface simulates a wood grain in each tile section. A matable interlock portion is formed on the edges of the sections for mechanically interlocking the tile to similarly staggered tiles having matable interlock portions thereon.

BRIEF DESCRIPTION OF THE DRAWINGS

[0015] FIG. 1 is a top plan view of a molded floor tile constructed in accordance with this invention.

[0016] FIG. 2 is a bottom plan view of the tile shown in FIG. 1.

[0017] FIG. 3 is an end elevational view of a first longitudinal edge portion of the tile of FIG. 2.

[0018] FIG. 4 is an end elevational view of a second longitudinal edge portion of the tile of FIG. 2.

[0019] FIG. 5 is an enlarged, partial cross-sectional view of two-interlocked floor tiles.

[0020] FIG. 6 is a partial cross-sectional view of a floor tile of FIG. 5, with a longitudinal groove formed therein to simulate the spacing between abutting edges of adjacent floorboards of a conventional wood floor section.

[0021] FIG. 7 is a top plan view of a floor assembly with similarly constructed and interlocked tiles having an applied wood grain decorative layer that simulates a conventional wood floor section with staggered flooring.

DETAILED DESCRIPTION OF THE INVENTION

[0022] FIG. 1 illustrates a tile 10 constructed in accordance with this invention. The tile 10 is typically extruded from a granular matrix of polymeric material, such as polyvinyl chloride material. The granular polyvinyl chloride matrix may have carpet fibers, which can be recycled from carpet scrap, dispersed throughout the matrix, as described in co-pending U.S. patent application Ser. No. 09/152,684, to provide a fiber-reinforced product should such be desired. That application is hereby incorporated by reference in its entirety herein.

[0023] The tile 10 is preferably made sufficiently flexible to provide some resilience and having a thickness ranging from approximately 0.20 inches to approximately 0.75 inches. In embodiments where recycled carpet scraps are used, a commercially available plasticizer may be mixed with the carpet material and the polyvinyl chloride in an amount to provide the desired flexibility to the extruded tile. Generally, the plasticizer is added to the polyvinyl chloride in an amount of up to about 5% by weight based on the total weight of the matrix mixture. The actual amount of plasticizer used will depend on the amount of polyvinyl chloride in the finished tile, the hardness of the added polyvinyl chloride and the amount of non-melting components in the carpet. In addition, the proportion of carpet fibers and the stiffness of the fibers will influence the flexibility of the tile 10. A higher proportion of fibers in the finished product generally produce a stiffer tile and requires a higher proportion of a plasticizer.

[0024] FIG. 1 shows a floor tile base section 12, which is capable of being used as a substrate to which one or more additional surfaces may be adhered. For example, a first layer that is adhered to tile base section 12 can be a decorative layer. A second layer can be a protective layer that resists scuffing an abrasion. As shown in FIG. 1, tile base section 12 is a flat, elongated substrate of polyvinyl chloride. As described in co-pending U.S. patent application Ser. No. 09/152,684, the tile base or substrate 12, (also referred to as

a backing herein) is typically made from recycled carpet squares and contains about 25% to about 90% by weight of flexible polyvinyl chloride and can also contain up to about 5% of a polyethylene copolymer. Alternatively, the base 12 may be fabricated from virgin polyvinyl chloride resin having a Shore A hardness ranging from, for example, about 40 to about 100 with little or no fiber content for reinforcement purposes.

[0025] The base 12 has a longitudinal axis A-A, a top surface (shown as element 13 in FIGS. 3 and 4), a bottom surface (shown as element 14 in FIGS. 3 and 4), and a pair of substantially linear side edges 16, and 17, respectively. The edges 16, 17 each lie in respective parallel planes designated 19 and 20, respectively. The axis A-A extends midway between the two side edges 16 and 17 of the base 12. The side edges 16 and 17 may be, and typically are, of equal length and terminate at their respective end edges. For example, side edge 16 has end edges 25 and 26 and side edge 17 has end edges 22 and 23.

[0026] The end edges 22, 23 and 25, 26 extend at right angles to the planes 20 and 19, respectively, inwardly toward the axis A-A and each other. Depending at right angles from the end edges 22 and 26 are longitudinally parallel side edges 24 and 27, respectively. The side edge 17 and its transverse end edges 22 and 23 define the exterior three sides of an edge section, or portion 28. Similarly, the opposite side edge 16 and adjoining edges 25, 26 and 27 define the exterior three sides of an edge section, or portion 30. Midsection 32, with end edges 34 and 35 is between edge sections 30 and 28.

[0027] End edges 22 and 23 of edge section 28 are displaced from end edges 34 and 35, respectively, of midsection 32. Midsection 32 has four exterior edges 34, 35, 37 and 39. The two end edges 34 and 35 are at substantially right angles to the axis A-A. The edge 37 joins the edge 34 at a substantially right angle and the edge 39 joins the edge 35, also at a substantially right angle.

[0028] As shown in FIG. 1, each section 28, 30 and 32 appears to be displaced in the longitudinal direction from its adjacent section because their transverse end edges are displaced from one another in the longitudinal direction. The displacements create a staggered appearance to the opposite linear end edges of the base 12, so that the opposite ends of the base simulate the stagger or longitudinal offsets, which typically occur between the abutting ends of floorboards of a conventional section of a wood floor. As will be apparent, the right angled ends of each base end form mutually inverted staircase-like structures, or step edges. As will be apparent to one skilled in the art, a particular application may require more or less than three stepped edges, then the base may be designed with such other desired greater or lesser number of stepped edges.

[0029] Each step is formed by abutting longitudinal and transverse end and side portions. Thus, as shown in FIG. 1, edges 17 and 23 form a first step edge; edges 35 and 39 form a second step; and edges 26 and 27 form a third step for a proximal end of tile base 12. Similarly, edges 17 and 22 form a first step; edges 34 and 24 form a second step; and edges 37 and 25 form a third step on for a distal end of tile base 12.

[0030] It is an embodiment of the present invention that the tile base, or substrate 12 may comprise only two sec-

tions, i.e., sections 30 and 28. In this embodiment, there is only one stepped, or staggered edge at each end of the tile base 12.

[0031] The ends of adjoining sections 28, 30 and 32 are typically spaced equal distances from one another in directions parallel to the axis A-A and this distance may range from about 6 inches to about 8 inches from end to end for typical installations. The length of each section may range from about 26 to about 32 inches, and the transverse dimensions mid-length of each section may range from about 2 inches to about 18 inches; again, depending on the requirements of a given installation. It will be recognized that one or more of these dimensions as well as the widths of each base section also may be unequal to achieve the desired surface appearance to the tile assembly.

[0032] To provide each section 28, 30 and 32 with a rectangularly sectioned top surface 13 that simulates a conventional wood board, grooves 40 and 41, are molded into the surface 13. The groove 40 is aligned with edges 24 and 39 to simulate a common edge between sections 28 and 32. The groove 41 is aligned with edge 27 and edge 37 to simulate a common abutting edge between sections 30 and 32. The grooves 40 and 41 are optional and may not be required, if for example, a decorative layer, which can be applied to the surface 13, embodies simulated grooves in the design of the layer or if the decorative layer embodies some other design appearance, which does not use grooves.

[0033] To provide interlock structures for the base 12 that are not visible from the top surface of the tile 10, two sets of hermaphroditic interlocks of this invention are formed in the bottom surface 14 of the base adjacent the border edges thereof. With references to FIGS. 1-4, the first set of interlocks, generally designated by the numeral 42 in FIG. 3, are positioned inwardly of the edges 16, 24, 25, 34 and 37, respectively, and the second set of interlocks, generally designated by the number 43, FIG. 4, are positioned inwardly of the edges 17, 23, 27, 35 and 39, respectively.

[0034] The interlocks are molded in the base and are spaced inwardly from corresponding adjacent base edges the same distance, as shown. The edges defining the interlocks are somewhat resilient because of the resilient nature of the base 12. Thus vertically aligned interlocks can be assembled with a mallet.

[0035] Each interlock is comprised of a vertically projecting male strip 45 and a laterally disposed female recess or slot 46. The recess 46 being a vertically disposed open-sided channel that mates with a male strip 45 of another tile 10-1, FIG. 5, to effect the interlock. The strip 45 is spaced laterally inwardly from the straight edges of the top surface 13 by its inwardly inclined edge 48. Thereby concealing the interlocks under the top surface 13. The recess 46 adjoins the strip 45 by way of a common, inwardly inclined surface 49, FIG. 5, providing mutually resilient catch structures that can be deflected to snap into mating relationship during installation. The open sides of its interlocks 42 and 43 on opposite respective sides and edges of the base face in opposite directions; interlock 42 opening downwardly and interlock 43 opening upwardly. Alternatively, opening 42 could open upwardly and interlock 43 downwardly.

[0036] The vertical distance between the surface 13 and the bottom of the recess 46 of interlock 42, FIG. 3, and the

vertical distance between the bottom surface 14 and the bottom of recess 46 of interlock 43 are made substantially equal. As illustrated, the interlocks 42 and 43 are essentially identical inverted counterparts with essentially identical dimensions. Thus, corresponding surfaces are designated by the same numbers in FIGS. 3 and 4.

[0037] Thus, as shown in FIG. 5, interlock 42 of tile 10 can be mated with an interlock 43 of an abutting tile designated 10-1 and the interlocks 43 similarly will mate with the interlocks 42 of tile 10-1 and adjoining tiles by simply driving the interlocks together. It is understood that an adjoining tile such as the tile assembly of FIG. 7, have the same inverted interlock arrangement as that illustrated by FIGS. 2 and 3. Because they are virtually inverted counterparts, and because of their mutual resilience, the interlocks of adjoining tiles will be tightly interlocked with their top and bottom surfaces substantially, and respectively, coplanar.

[0038] Since temperature and environmental conditions, which may effect internal contracting and/or expanding displacements in the tile, are likely to occur along longitudinal planes, the end edges 22 and 26, which are spaced farthest apart are not provided with any transverse interlocks. Such interlocks, if mated, might be disrupted by contracting or expanding displacements after installation.

[0039] With the base 12 molded to simulate the structured appearance of a section of wood flooring, the base 12 may have a decorative layer and if desired, a wear layer laminated to the decorative layer. With reference to FIGS. 5, 6 and 7, a decorative layer 50 simulating the appearance of wood grain is adhered to the top surface 13. The layer 50 may, for example, comprise a photographic image of a wood floor section laminated over an adhesive backing, which will adhere to the surface 13 of the previously extruded base upon the application of heat and pressure, for example. Advantageously, a decorative layer of a polymeric composition may be applied to the base 12 during an injection molding process employed to mold the base by placing the layer in laminar form into an open mold constructed of two halves before the mold halves are driven together to form the base. Upon solidification of the base, the mold is then opened to remove the decorative tile 10. Other materials and processes may be used to create and adhere a decorative laminate to the surface 13.

[0040] As shown in FIG. 4, the outermost horizontal surface of the male strip 45 is substantially below the adjacent top surface 13. This enables a more precise application of the decorative layer to the surface 13; the edge of surface 13 being sharply enough defined and offset to prevent the catch recess 46 from readily receiving and being covered by edge portions of the ornamental layer applied to the top 13.

[0041] In addition to the decorative layer 50, a transparent wear-resistant layer 52 may be adhered to the layer 50. The layer 52 may be a film of transparent polyurethane, for example, having a thickness in the range of about 200 to 800 microns.

[0042] As shown in FIGS. 6 and 7, if grooves 40 and 41 are formed on the surface 13, the decorative layer 50 may be pressed with the grooves to simulate the common space between abutting wooden boards. The wear layer 52 may

also be applied with a brush or roller to the hardened layer 52. It is understood, however, that neither the thickness of the layers 50 or 52 or their particular compositions are critical to the practice of this invention.

[0043] The present invention has been described in detail by way of examples and illustrations for purposes of clarity and understanding, and not to in any way limit the scope of what is claimed. Those skilled in the art will understand that certain changes and modifications may be made without departing from the scope of the invention.

What is claimed is:

1. A floor tile comprising:
 - a flat, elongated base having a top surface, a bottom surface a distal end and a proximal end;
 - first and second opposite sides lying in respective first and second substantially parallel side planes;
 - a longitudinal axis disposed between and substantially parallel to said side planes; and
 - one or more stepped edges formed on each of said distal and proximal ends of the base, the one or more stepped edges formed by adjoining longitudinal and transverse edge portions, the longitudinal edge portion of one said edge lying in a longitudinal plane inward of one of said side planes and extending substantially parallel thereto.
2. The tile as claimed in claim 1, wherein the longitudinal edge portions of the opposite ones of the stepped edges lie in the same longitudinal plane, whereby opposite stepped edges are in longitudinal alignment.
3. The tile as claimed in claim 1, further comprising:
 - first and second interlock surfaces on said base extending substantially parallel to each of said first and second sides respectively for locking the tile to one or more similar adjacent tiles.
4. The tile as claimed in claim 3, wherein the first and second interlock surfaces on the base face inward.
5. The tile as claimed in claim 3, wherein each of said interlock surfaces comprises an hermaphroditic interlock structure having first and second sidewalls spaced apart to form a partially enclosed, open-sided cavity facing outwardly from said base.
6. The tile as claimed in claim 5, wherein the first interlock sidewall is the outermost sidewall, and wherein said sides of said base and said first sidewall form there between the male part of said interlock structure.
7. The tile as claimed in claim 5, wherein said first sidewall is inclined toward said first side with a slope of opposite polarity to that of the first sidewall adjacent said second side of said base.
8. The tile as claimed in claim 1, further comprising an interlock surface formed in the base of said end inwardly of the edges of said step edges.
9. The tile as claimed in claim 1, wherein the distal end of the base is formed by a first, second and third step.
10. The tile as claimed in claim 9, wherein each step on the distal end of the base has a longitudinally aligned step on the proximal end of the base.
11. The tile as claimed in claim 1, further comprising a plurality of said stepped edges on each of said distal and proximal ends of the base, thereby forming a stepped staircase arrangement, the staircase arrangement at one of

said base ends being inverted with respect to the staircase arrangement at the opposite base end.

12. The tile as claimed in claim 11, wherein the steps of one of said staircase arrangements are longitudinally aligned with corresponding steps of an opposite staircase arrangement.

13. The tile as claimed in claim 1 or 2, further comprising:

- a decorative layer adhered to the top surface of the base.

14. The tile as claimed in claim 13, wherein the base is formed by an injection molding process and wherein the decorative layer is a laminate molded to the base during the process.

15. The tile as claimed in claim 1, further comprising, a wear-resistant layer adhered to the top surface of the base.

16. The tile as claimed in claim 14, further comprising, a wear-resistant layer adhered to the decorative layer.

17. The tile according to claim 13, wherein the base is at least partially composed of recycled plastic material.

18. The tile as claimed in claim 13, wherein the decorative layer simulates the surface of a wooden floor, and additionally, wherein a plurality of longitudinally extending, parallel grooves are molded in said top surface to simulate a plurality of boards.

19. The tile as claimed in claim 18, wherein each of said grooves is aligned with longitudinal edge portions of oppositely aligned step edges.

20. The tile as claimed in claim 1, wherein the step edges have longitudinal and transverse intersecting portions to simulate transverse staggering between individual boards a wood floor

21. A floor tile assembly comprising:

- a plurality of mutually adjacent tiles mechanically interlocked along the sides thereof for adhesive-free mounting to a surface,

wherein, each of said tiles comprises an elongated base of substantially rectangular cross-section having a longitudinal axis, a top and bottom surface and first and second substantially linear peripheral edges forming substantially straight borders, a pair of open-sided interlock structures molded in said base extending parallel to and adjacent to different ones of said first and second edges, the open side of the interlock structure adjacent the first side edge facing the bottom surface is disposed to engage a mating interlock structure of another adjacent tile from the top of said base, and a plurality of transverse stepped end surfaces formed on opposite ends of said base.

22. The tile assembly according to claim 21, further comprising:

- a decorative layer adhering to said top surface of each tile simulating a section of a wood floor.

23. The tile assembly according to claim 21, wherein the transversely stepped end surfaces on each tile are formed by a staircase of individual steps; each step having longitudinal and transverse intersecting portions to simulate transverse staggering between individual boards a wood floor.

24. The tile assembly according to claim 21, wherein the step staircases are positionally inverted relative to a central plane through a said base and perpendicular to said longitudinal axis, and wherein each step has a longitudinally disposed diagonal counterpart step on an opposite base end.

25. The tile assembly according to claim 21, further comprising:

a plurality of top longitudinal grooves, each groove aligned with a longitudinal portion of a step and its opposite counterpart to simulate the longitudinally abutting edges of boards of a wood floor.

26. A floor tile molded of polymeric material, comprising:

a plurality of flat, elongated tile sections of substantially equal length and each of the plurality of tile sections having adjoining top surfaces of generally rectangular shape, said plurality of tile sections being joined in parallel longitudinally staggered relationship to simulate the staggering of abutting elongated boards in a wooden floor installation, a decorative layer on said top surface simulating a wood grain in each tile section, and matable interlock portion formed on the edges of said sections for mechanically interlocking the tile to similarly staggered tiles having matable interlock portions thereon.

27. A tile according to claim 26, wherein each tile section is longitudinally spaced from its adjoining section of tile by substantially the same amount.

28. An interlock structure for a resilient plastic tile having top and bottom surfaces and a peripheral edge, with linear edge portions, the structure comprising:

a substantially linear strip formed in the bottom surface and extending to a position below said top surface, said strip and extending inwardly and parallel to an edge portion and formed by the intersection of two strip wall portions, one of the wall portions of the said strip having an inclined, outwardly projected surface and the other wall extending parallel to said top surface for forming a catch portion of the structure, and an open-sided channel having opposed walls extending parallel to and adjacent said projecting surface, said channel wall having an inwardly inclined surface for engaging a catch portion of a second tile, the open side of said channel facing the bottom surface of said tile for locking into said second tile; and

a decorative layer adhered to the top surface.

* * * * *