



(12) **United States Design Patent**
Bernard et al.

(10) **Patent No.:** **US D882,699 S**
(45) **Date of Patent:** **** Apr. 28, 2020**

(54) **GAMING MACHINE CAROUSEL DISPLAY**
(71) Applicant: **BALLY GAMING, INC.**, Las Vegas, NV (US)

4,861,037 A 8/1989 Oursler
4,960,117 A 10/1990 Moncrief et al.
4,981,298 A 1/1991 Lawlor et al.
D315,110 S 3/1991 Slater
5,015,189 A 5/1991 Wenzinger
D318,660 S 7/1991 Weber

(72) Inventors: **Vernon Bernard**, Las Vegas, NV (US);
Karl Wudtke, Las Vegas, NV (US)

(Continued)

(73) Assignee: **SG Gaming, Inc.**, Las Vegas, NV (US)

FOREIGN PATENT DOCUMENTS

(**) Term: **15 Years**

EP 649 671 A1 4/1995
JP 03210172 B2 9/2001

(Continued)

(21) Appl. No.: **29/600,744**

(22) Filed: **Apr. 14, 2017**

OTHER PUBLICATIONS

(51) **LOC (12) Cl.** **21-01**

Product Sheet for "American Eagle," Eagle Co. Ltd., 1997 (2 pages).

(52) **U.S. Cl.**
USPC **D21/385**

(Continued)

(58) **Field of Classification Search**
USPC D21/324, 325, 329, 330, 331, 332, 333,
D21/385; D14/496, 125, 126, 127, 128,
D14/129, 133, 217, 239; D26/118, 119,
D26/120, 121, 122
CPC G06F 1/1601; G06F 1/1603; G06F 1/1605;
G06F 1/1647; G06F 1/1652
See application file for complete search history.

Primary Examiner — George D. Kirschbaum
Assistant Examiner — Joseph J. Kukella
(74) *Attorney, Agent, or Firm* — Banner & Witcoff, Ltd.

(57) **CLAIM**

The ornamental design for a gaming machine carousel display, as shown and described.

(56) **References Cited**

DESCRIPTION

U.S. PATENT DOCUMENTS

- 2,661,954 A 12/1953 Koci
- D236,720 S 9/1975 Baker
- D238,379 S 1/1976 Miller
- 4,046,419 A 9/1977 Schmitt
- D264,485 S 5/1982 Kitchen
- 4,372,557 A 2/1983 Del Principe et al.
- 4,373,725 A 2/1983 Ritchie
- D275,772 S 10/1984 Akopian et al.
- D280,835 S 10/1985 Berge et al.
- D280,836 S 10/1985 Ludzia et al.
- 4,606,545 A 8/1986 Ritchie
- 4,705,274 A 11/1987 Lubeck
- 4,840,343 A 6/1989 Gasser

FIG. 1 is a front perspective view of a gaming machine carousel display showing our new design;
FIG. 2 is a front view thereof;
FIG. 3 is a rear view thereof;
FIG. 4 is a right side view thereof;
FIG. 5 is a left side view thereof;
FIG. 6 is a top view thereof; and,
FIG. 7 is a bottom view thereof.

The broken line showing of the remainder of the gaming machine represents unclaimed subject matter and forms no part of the claimed design.

1 Claim, 7 Drawing Sheets

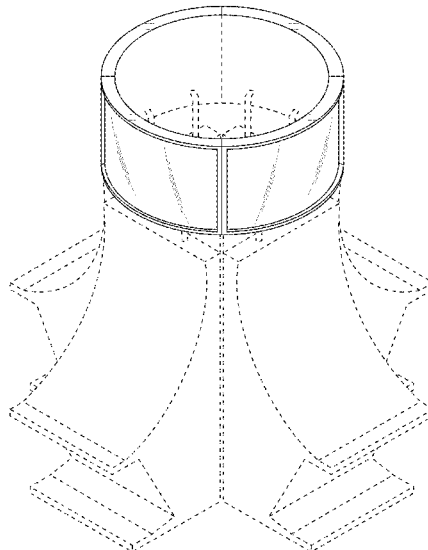

(56)

References Cited

U.S. PATENT DOCUMENTS

5,074,558	A	12/1991	Bleich et al.	D417,145	S	11/1999	McLaughlin
5,083,738	A	1/1992	Infanti	5,984,782	A	11/1999	Inoue
5,091,677	A	2/1992	Bleich et al.	6,000,697	A	12/1999	Popadiuk et al.
5,102,192	A	4/1992	Barile, Sr.	D419,201	S	1/2000	de Haas
5,110,120	A	5/1992	Smolucha	D419,606	S	1/2000	Toriyama
5,114,112	A	5/1992	Infanti	6,036,188	A	3/2000	Gomez et al.
5,120,058	A	6/1992	Trudeau et al.	6,047,962	A	4/2000	Popadiuk
5,123,647	A	6/1992	Lawlor et al.	6,047,963	A	4/2000	Pierce et al.
5,143,055	A	9/1992	Eakin	D424,122	S	5/2000	Dickenson et al.
5,149,094	A	9/1992	Tastad	6,071,190	A	6/2000	Weiss et al.
D333,164	S	2/1993	Kraft et al.	D428,062	S	7/2000	Hayashi
5,193,807	A	3/1993	Schilling et al.	6,089,663	A	7/2000	Hill
5,195,746	A	3/1993	Boyd et al.	6,102,394	A	8/2000	Wurz et al.
D335,150	S	4/1993	Biagi et al.	6,113,097	A	9/2000	Krutsch et al.
5,226,653	A	7/1993	Bil et al.	6,117,010	A	9/2000	Canterbury et al.
5,232,191	A	8/1993	Infanti	6,120,021	A	9/2000	Piotrowski et al.
5,290,034	A	3/1994	Hineman	6,129,353	A	10/2000	DeMar et al.
5,297,793	A	3/1994	DeMar et al.	6,129,355	A	10/2000	Hahn et al.
5,316,303	A	5/1994	Trudeau et al.	6,135,449	A	10/2000	Cornell et al.
5,322,283	A	6/1994	Ritchie et al.	6,135,562	A	10/2000	Infanti
5,326,104	A	7/1994	Pease et al.	6,149,153	A	11/2000	Sheats, Jr.
5,350,174	A	9/1994	Ritchie et al.	6,155,565	A	12/2000	Gomez et al.
D351,869	S	10/1994	Rothschild et al.	6,155,925	A	12/2000	Giobbi et al.
5,351,954	A	10/1994	Oursler et al.	6,158,737	A	12/2000	Cornell et al.
5,357,104	A	10/1994	Bleich	6,159,098	A	12/2000	Slomiany et al.
5,358,241	A	10/1994	Anghelo et al.	6,164,644	A	12/2000	Cornell et al.
5,358,242	A	10/1994	Trudeau et al.	6,173,955	B1	1/2001	Perrie et al.
5,358,243	A	10/1994	Eddy et al.	6,199,861	B1	3/2001	Hume et al.
D352,738	S	11/1994	Anghelo et al.	D439,931	S	4/2001	Yamaguchi
5,383,663	A	1/1995	Anghelo et al.	6,210,279	B1	4/2001	Dickinson
5,405,144	A	4/1995	Ritchie et al.	6,224,482	B1	5/2001	Bennett
5,409,296	A	4/1995	Barile	6,227,614	B1	5/2001	Rubin
5,411,257	A	5/1995	Fulton	6,227,970	B1	5/2001	Shimizu et al.
5,415,402	A	5/1995	Morrison et al.	D443,313	S	6/2001	Brettschneider
5,415,403	A	5/1995	Ritchie et al.	D446,252	S	8/2001	Yamaguchi
5,417,423	A	5/1995	Oursler et al.	6,283,546	B1	9/2001	Hill
5,417,425	A	5/1995	Blumberg et al.	6,290,229	B1	9/2001	Perez
5,437,453	A	8/1995	Hineman	D450,094	S	11/2001	Hedrick et al.
5,465,963	A	11/1995	Patla, Sr.	6,334,612	B1	1/2002	Wurz et al.
5,472,197	A	12/1995	Gwiasda et al.	6,354,660	B1	3/2002	Friedrich
5,494,286	A	2/1996	DeMar et al.	D459,402	S	6/2002	Wurz et al.
5,507,488	A	4/1996	Eddy et al.	6,422,670	B1	7/2002	Hedrick et al.
5,511,783	A	4/1996	Popadiuk et al.	6,422,941	B1	7/2002	Thorner et al.
5,516,103	A	5/1996	Lawlor et al.	6,439,993	B1	8/2002	O'Halloran
5,522,641	A	6/1996	Infanti	D463,504	S	9/2002	Stephan
5,524,887	A	6/1996	Trudeau et al.	D464,377	S	10/2002	Wurz et al.
5,533,726	A	7/1996	Nordman et al.	D465,813	S	11/2002	Randall
5,542,748	A	8/1996	Barile	D466,160	S	11/2002	Hirato et al.
D376,391	S	12/1996	Okumura	D467,977	S	12/2002	Gatto et al.
5,580,052	A	12/1996	Popadiuk et al.	D468,364	S	1/2003	Beadell et al.
5,632,482	A	5/1997	Anghelo	6,530,842	B1	3/2003	Wells et al.
D380,014	S	6/1997	Yang	6,530,872	B2	3/2003	Frehland et al.
5,655,965	A	8/1997	Takemoto et al.	6,572,187	B2	6/2003	Laufer
5,664,777	A	9/1997	Nordman et al.	6,589,114	B2	7/2003	Rose
5,669,818	A	9/1997	Thorner et al.	6,609,972	B2	8/2003	Seelig et al.
5,678,886	A	10/1997	Infanti	6,616,142	B2	9/2003	Adams
5,697,612	A	12/1997	Piotrowski et al.	6,620,047	B1	9/2003	Alcorn et al.
5,704,835	A	1/1998	Dietz, II	D481,078	S	10/2003	Stephan
5,707,059	A	1/1998	Sullivan et al.	6,646,695	B1	11/2003	Gauselmann
5,720,480	A	2/1998	Lawlor et al.	6,652,378	B2	11/2003	Cannon et al.
D395,463	S	6/1998	Scott et al.	D483,075	S	12/2003	Kang
5,762,617	A	6/1998	Infanti	D484,548	S	12/2003	Franco Munoz et al.
5,791,731	A	8/1998	Infanti	D485,583	S	1/2004	Porto
5,806,851	A	9/1998	Gomez et al.	6,715,756	B2	4/2004	Inoue
5,820,460	A	10/1998	Fulton	6,729,618	B1	5/2004	Koenig et al.
5,833,236	A	11/1998	Oursler et al.	D492,363	S	6/2004	Seelig et al.
D405,473	S	2/1999	Tikhonski et al.	D492,364	S	6/2004	Seelig et al.
D407,759	S	4/1999	Isetani et al.	D492,365	S	6/2004	Munoz et al.
D408,366	S	4/1999	Popadiuk	D492,676	S	7/2004	Monson et al.
5,890,715	A	4/1999	Gomez et al.	D493,843	S	8/2004	Jackson, Sr. et al.
5,899,454	A	5/1999	Eddy et al.	D493,846	S	8/2004	Seelig et al.
5,924,690	A	7/1999	Kopera et al.	D495,754	S	9/2004	Wurz et al.
5,934,672	A	8/1999	Sines et al.	D495,755	S	9/2004	Wurz et al.
5,938,195	A	8/1999	Anghelo et al.	D498,267	S	11/2004	Crouch
5,944,309	A	8/1999	Popadiuk et al.	D500,098	S	12/2004	Doi
				6,880,825	B2	4/2005	Seelig et al.
				D505,162	S	5/2005	Bristol et al.
				D508,268	S	8/2005	Hanchar et al.
				D508,269	S	8/2005	Wichinsky

(56)

References Cited

U.S. PATENT DOCUMENTS

D508,719 S	8/2005	de Haas	8,002,626 B2	8/2011	Englman	
D508,961 S	8/2005	Gatto et al.	D646,336 S	10/2011	Kelly et al.	
D509,254 S	9/2005	Rasmussen et al.	D646,337 S	10/2011	Kelly et al.	
D509,255 S	9/2005	Bristol et al.	D646,691 S	10/2011	Thai et al.	
D512,105 S	11/2005	Chitrapongse et al.	D649,605 S	11/2011	Terpstra et al.	
D513,511 S	1/2006	Decombe	D651,608 S	1/2012	Allen et al.	
D515,144 S	2/2006	Boyd	8,152,623 B2	4/2012	Fiden	
6,997,810 B2	2/2006	Cole	8,162,740 B2	4/2012	Aoki	
D520,504 S	5/2006	Martin	8,216,061 B2	7/2012	Pacey	
7,063,615 B2	6/2006	Alcorn et al.	8,267,764 B1	9/2012	Aoki et al.	
7,108,237 B2	9/2006	Gauselmann	D669,076 S	10/2012	Haller	
D531,677 S	11/2006	Mallory et al.	8,292,451 B2	10/2012	Hwang et al.	
7,184,277 B2	2/2007	Beime	8,303,420 B2	11/2012	Chudek et al.	
D537,885 S	3/2007	Gadda et al.	8,305,743 B2	11/2012	Wu et al.	
D539,854 S	4/2007	Luciano et al.	8,323,114 B2	12/2012	Burak et al.	
D540,398 S	4/2007	Gadda et al.	D673,620 S	1/2013	Johnson et al.	
D546,893 S	7/2007	Yamashita	8,353,755 B2	1/2013	Vann et al.	
7,247,098 B1	7/2007	Bradford et al.	8,371,920 B2	2/2013	Gomez et al.	
D548,801 S	8/2007	Groswirt	8,371,927 B2	2/2013	Englman	
D549,785 S	8/2007	Luciano, Jr. et al.	8,371,928 B2	2/2013	Englman et al.	
7,267,612 B2	9/2007	Alcorn et al.	8,376,832 B2	2/2013	O'Connor et al.	
D554,710 S	11/2007	Malone et al.	D678,955 S	3/2013	Lesley et al.	
D556,765 S	12/2007	Evans et al.	D678,956 S	3/2013	Lesley et al.	
D557,748 S	12/2007	Jumper	D678,957 S	3/2013	Cesaroni et al.	
D559,328 S	1/2008	Rasmussen et al.	D678,958 S	3/2013	Cesaroni et al.	
D559,917 S	1/2008	Cole	D681,130 S	4/2013	Lesley et al.	
D560,724 S	1/2008	Johnson	8,430,756 B2	4/2013	McComb et al.	
D560,725 S	1/2008	Johnson	D682,948 S	5/2013	Cesaroni et al.	
D563,326 S	3/2008	Patel et al.	D685,033 S	6/2013	Wudtke	
D563,481 S	3/2008	Looks et al.	D691,661 S *	10/2013	Creech	D21/324
D564,600 S	3/2008	Greenberg et al.	D691,665 S	10/2013	Chudek	
D564,601 S	3/2008	Strahinic et al.	D691,666 S	10/2013	Lesley et al.	
D566,197 S	4/2008	Greenberg et al.	D693,343 S	11/2013	Haller	
D569,863 S	5/2008	Feldstein et al.	D697,558 S *	1/2014	Myers	D21/325
D572,314 S	7/2008	Vallejo et al.	D704,273 S	5/2014	Chudek	
D578,168 S	10/2008	Looks et al.	D704,275 S	5/2014	Lesley et al.	
D581,983 S	12/2008	Bergstrom	D706,741 S	6/2014	Myers	
RE40,625 E	1/2009	Wurz et al.	D712,975 S	9/2014	Lesley et al.	
7,479,066 B2	1/2009	Emori	D714,875 S *	10/2014	Wudtke	D21/385
D587,272 S	2/2009	Morrow et al.	D715,364 S *	10/2014	Wudtke	D21/385
D587,319 S	2/2009	Moises Deiab	8,982,545 B2	3/2015	Kim et al.	
RE40,671 E	3/2009	Wurz et al.	D730,993 S	6/2015	Castro et al.	
7,503,849 B2	3/2009	Hornik et al.	D740,888 S	10/2015	DePalma et al.	
D590,025 S	4/2009	Fiore	D742,974 S	11/2015	Lesley et al.	
D594,068 S	6/2009	Hsu	D742,975 S	11/2015	Myers et al.	
D596,678 S	7/2009	Myers	D744,579 S *	12/2015	Cope	D16/241
D599,365 S	9/2009	Brown et al.	D760,846 S	7/2016	Castro et al.	
D599,858 S	9/2009	Lesley et al.	RE46,169 E	10/2016	Kelly et al.	
D599,859 S	9/2009	Lesley	D780,852 S *	3/2017	Sharp	D14/203.7
D599,860 S	9/2009	Lesley et al.	D802,675 S *	11/2017	Steelman	D21/325
D601,638 S	10/2009	Palmisano	D805,588 S *	12/2017	Sharp	D21/329
D604,368 S	11/2009	Lesley et al.	D810,830 S *	2/2018	Sharp	D21/329
7,628,693 B2	12/2009	Thomas	D832,357 S *	10/2018	Castro	D21/369
7,666,085 B2	2/2010	Vorias et al.	D832,358 S *	10/2018	Castro	D21/369
7,686,689 B2	3/2010	Thomas	D843,461 S *	3/2019	Castro	D21/369
D613,802 S	4/2010	Meyers et al.	D843,462 S *	3/2019	Castro	D21/369
D615,598 S	5/2010	McComb et al.	D843,463 S *	3/2019	Castro	D21/369
7,713,119 B2	5/2010	Pacey et al.	D858,641 S *	9/2019	Legras	D21/370
D622,780 S	8/2010	Lesley et al.	D858,642 S *	9/2019	Legras	D21/370
D622,781 S	8/2010	Lesley et al.	2002/0041069 A1	4/2002	Steelman	
D622,782 S	8/2010	Chudek et al.	2003/0122973 A1	7/2003	Huang	
D626,182 S	10/2010	Cole et al.	2004/0018877 A1	1/2004	Tastad et al.	
D626,183 S	10/2010	Cole et al.	2004/0029631 A1	2/2004	Duhamel	
7,811,167 B2	10/2010	Giobbi et al.	2004/0053662 A1	3/2004	Pacey	
D631,060 S	1/2011	Flik et al.	2005/0014547 A1	1/2005	Gomez et al.	
D631,100 S	1/2011	Palmisano	2006/0009284 A1	1/2006	Schwartz et al.	
D633,950 S	3/2011	Terpstra et al.	2006/0034042 A1	2/2006	Hisano et al.	
D637,238 S	5/2011	O'Keene et al.	2006/0079316 A1	4/2006	Flemming et al.	
D637,652 S	5/2011	Tahara et al.	2006/0131810 A1	6/2006	Nicely	
7,938,728 B2	5/2011	Vetter et al.	2006/0183553 A1	8/2006	Kiriyama et al.	
7,955,176 B2	6/2011	Tastad et al.	2006/0199638 A1	9/2006	Walker et al.	
D641,047 S	7/2011	Tahara et al.	2006/0281559 A1	12/2006	Luciano	
7,976,393 B2	7/2011	Haga et al.	2006/0287111 A1	12/2006	Mitchell et al.	
7,985,139 B2	7/2011	Lind et al.	2008/0039213 A1	2/2008	Cornell et al.	
8,002,424 B2	8/2011	Hwang et al.	2008/0051202 A1	2/2008	Lube	
			2009/0174996 A1	7/2009	Park	
			2010/0053231 A1	3/2010	Park	
			2012/0122569 A1	5/2012	Kowolik et al.	
			2012/0168058 A1	7/2012	Kim et al.	

(56)

References Cited

U.S. PATENT DOCUMENTS

2013/0180653	A1	7/2013	Kim et al.
2013/0278875	A1	10/2013	Kim et al.
2014/0055696	A1	2/2014	Lee et al.
2014/0092356	A1	4/2014	Afin et al.
2014/0176856	A1	6/2014	Lee et al.
2014/0226111	A1	8/2014	Kim
2014/0226112	A1	8/2014	Kim
2014/0354938	A1	12/2014	Kim
2014/0368782	A1	12/2014	Kim et al.
2014/0375936	A1	12/2014	Park et al.
2015/0000823	A1	1/2015	Kim et al.
2015/0036073	A1	2/2015	Im et al.
2015/0116621	A1	4/2015	Park et al.
2015/0116625	A1	4/2015	Hwang et al.
2015/0301390	A1	10/2015	Kim

FOREIGN PATENT DOCUMENTS

KR	1113734	B1	2/2012
KR	2012051630	A	5/2012
KR	1268471	B1	6/2013
KR	1278904	B1	6/2013
KR	1336677	B1	12/2013
KR	1381609	B1	4/2014
KR	1381610	B1	4/2014
KR	2015013987	A	2/2015
KR	1539221	B1	7/2015
TW	200949775	A	12/2009

OTHER PUBLICATIONS

Product Sheet for "Monopoly Chairman of the Board™," WMS Gaming Inc., 1999 (2 pages).

Product Sheet for "American Eagle," Eagle Co., Ltd., 2000 (2 pages).

Product Sheet for "Survivor," WMS Gaming Inc., 2001 (4 pages).

Product Sheet for "ProSLOT® 6000," Bally Gaming Systems, 2002 (4 pages).

Product Sheet for "EVO™ Hybrid," Bally Gaming Systems, 2002 (4 pages).

Product Sheet for "3RV™," WMS Gaming Inc., 2002 or earlier (2 pages).

Product Sheet for "Miss America," AC Coin & Slot, 2002 or earlier (2 pages).

Product Catalog for Ainsworth Game Technology Ltd, date estimated as early as 2007 (6 pages).

Product Sheet for "Ultrapin™," Global VR, 2007 (1 pages).

Brochure for "Virtual Pinball," Tab-Austria, 2007 (8 pages).

Catalog for Atronice®-Spielo®, date estimated as early as 2008 (2 pages).

Product Catalog for "Alpha Elite™," Bally Technologies, date estimated as early as 2008-2009 (2 pages).

Cabinet Brochure for Hydako Co., date estimated as early as 2009 (1 page).

Product Catalog for Bally Technologies, date estimated as early as 2010 (2 pages).

Fall & Winter Catalog for Aristocrat, date estimated as early as 2010-2011 (7 pages).

Catalog for "Your Partner Innovation," Bally Technologies, date estimated as early as 2011 (4 pages).

Co-pending Design U.S. Appl. No. 29/559,629, filed Mar. 30, 2016.

Co-pending Design U.S. Appl. No. 29/559,613, filed Mar. 30, 2016.

Co-pending Design U.S. Appl. No. 29/559,593, filed Mar. 30, 2016.

Immersaview, "Why choose a Curved Screen for your Multi-Projector Setup", Jan. 28, 2016; retrieved from <https://www.immersaview.com/resources/why-curved/> (7 pages).

Denison; "Why can't you buy a flat OLED yet? The curve isn't just about viewing experience"; Digital Trends; Aug. 18, 2013; retrieved from <http://www.digitaltrends.com/home-theater-why-did-the-use-get-stuck-with-curved-oled/#!zXypT> (8 pages).

Wilcox, "LG, Samsung, and Sony throw TV buyers a curve"; Consumer Reports; Sep. 10, 2013; retrieved from <http://www.consumerreports.org/cro/news/2013/09/curved-tv-screens/index.htm#> (1 page).

Snider; "Sony tosses latest pitch for curved TV displays"; USA Today; Oct. 15, 2013; retrieved from <http://www.usatoday.com/story/tech/personal/2013/10/15/new-curved-sony-led-hdtv/2982051/> (2 pages).

Morrison; "Curved OLED HDTV screens are a bad idea (for now)"; CNET; Jun. 18, 2013; retrieved from <https://www.cnet.com/news/curved-oled-hdtv-screens-are-a-bad-idea-for-now/> (9 pages).

Cochran; "Why Samsung's curved-screen TV might be a 'game changer'"; CBS News; Aug. 14, 2013; retrieved from <http://www.cbsnews.com/news/why-samsungs-curved-screen-tv-might-be-a-game-changer/> (3 pages).

Kelly; "TV trends at CES: 4K, curves and smart TVs"; CNN; Jan. 8, 2014; retrieved from <http://www.cnn.com/2014/01/07/tech/gaming-gadgets/ces-television-trends/> (5 pages).

Manjoo; "TV Makers Are Out of Ideas"; Wall Street Journal; Jan. 8, 2014; retrieved from <https://www.wsj.com/news/articles/SB10001424052702303393804579308801012230792> (4 pages).

Daniel; "Curved Monitors—Overview"; Curved Monitor Test; Aug. 28, 2015; retrieved from <http://www.curved-monitor-test.de/> (5 pages).

Matthias; "Curved TV—Overview"; Curved TV Test; Apr. 20, 2016; retrieved from <https://technikblog.net/fernseher-test/curved-tv/> (16 pages, in German).

Ljt216; "Flat Screen vs Curved CRTs for Retro Games"; Reddit; Jul. 29, 2015; retrieved from <https://www.reddit.com/r/gamecollecting/comments/3f25r0/flat_screen_vs_curved_crts_for_retro_games/> (4 pages).

Photonics Industry and Technology Development Association (PIDA); "E-Paper Shows Potential at Creating a Paperless Haven"; OptoLink Magazine, 3 Quarter 2008; pp. 8-11 (4 pages).

AU Optronics Corp.; News Center: "AUO Announces Multiple Upcoming Innovations"; Oct. 27, 2008; retrieved from <http://www.auo.com/?sn=107&lang=en-US&c=10&n=363>; (2 pages).

Digitimes, Inc.; "FPD China 2009: AUO 8.9-inch convex display panel"; Mar. 12, 2009; retrieved from <http://www.digitimes.com/photogallery/showphoto.asp?ID=3376>; (3 pages).

Gizmodo.com; "AUO Curved Displays, Ultra Thin LCDs On the Way"; May 20, 2008; retrieved from <http://gizmodo.com/392248/auo-curved-displays-ultra-thin-lcds-on-the-way>; (2 pages).

PC World; "AU Optronics Shows Off Curved LCD Screen"; May 20, 2008; retrieved from <http://www.pcworld.com/article/146083/article.amp.html> (3 pages).

DailyTech; "AUO Shows Off Curved Display and Touch Screen"; May 23, 2008; retrieved from <http://www.dailytech.com/AUO+Shows+Off+Curved+Display+and+Touch+Screen+Tech/article11845.htm>; (2 pages).

OLED-Info; "LG Phillips LCD Develops 14.3-Inch Color E-Paper Display"; Jan. 4, 2008; retrieved from <http://www.oled-info.com/lg/lg_phillips_lcd_develops_14_3_inch_color_e_paper_display>; (2 pages).

NewLaunches.com; "LG Phillips LCD develops world's highest resolution 14.3 inch flexible color E-paper display!"; Jan. 3, 2008; retrieved from <http://newlaunches.com/archives/lgphillips_lcd_develops_worlds_highest_resolution_143inch_flexible_color_epaper_display.php>; (4 pages).

Series of Screenshots from video: Wood, Molly (Mar. 26, 2015).

Major, Clare, Carr, Vanessa, eds. <https://www.nytimes.com/video/technology/personaltech/100000002788325/curved-screens-worth-it.html>

* cited by examiner

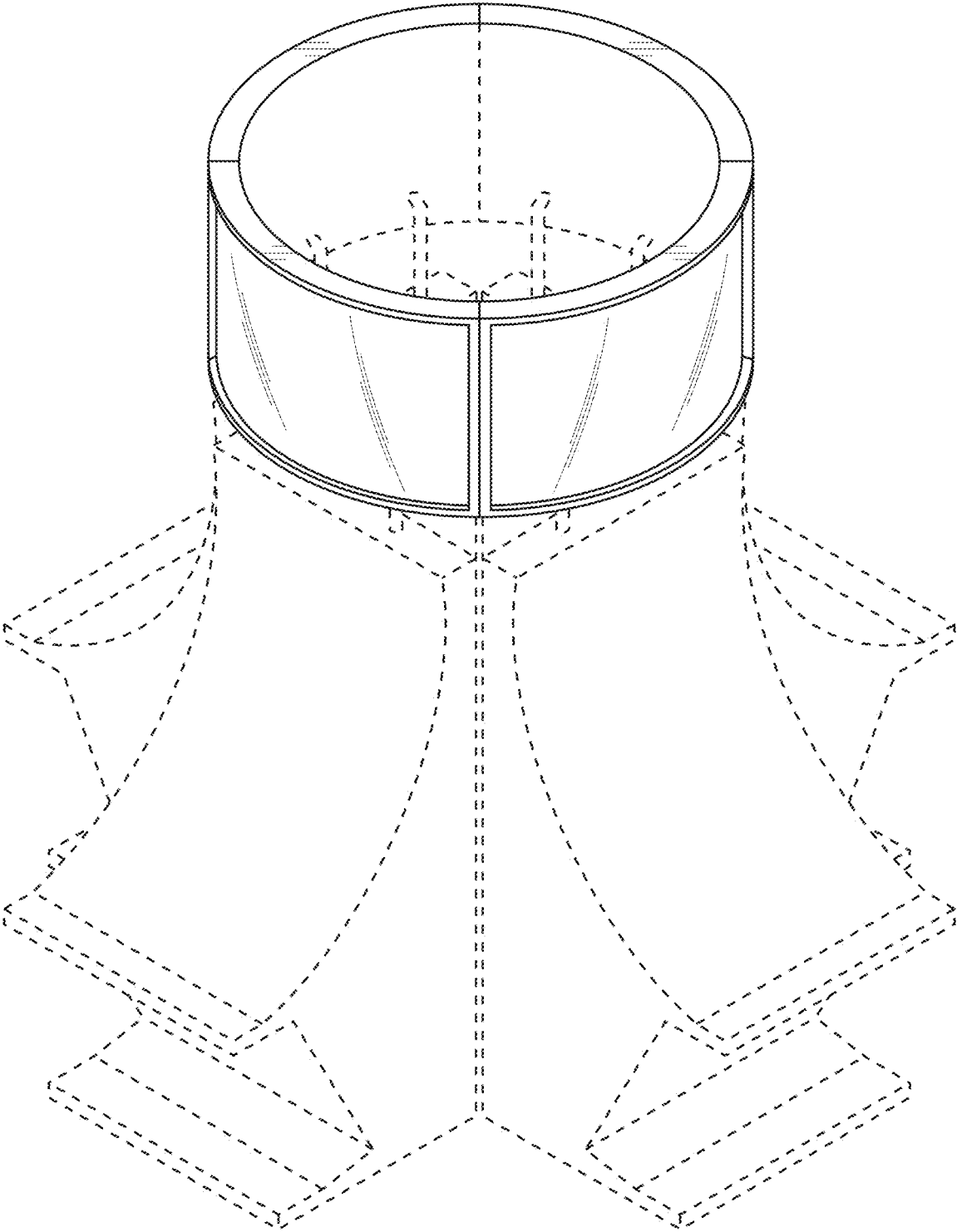

FIG. 1

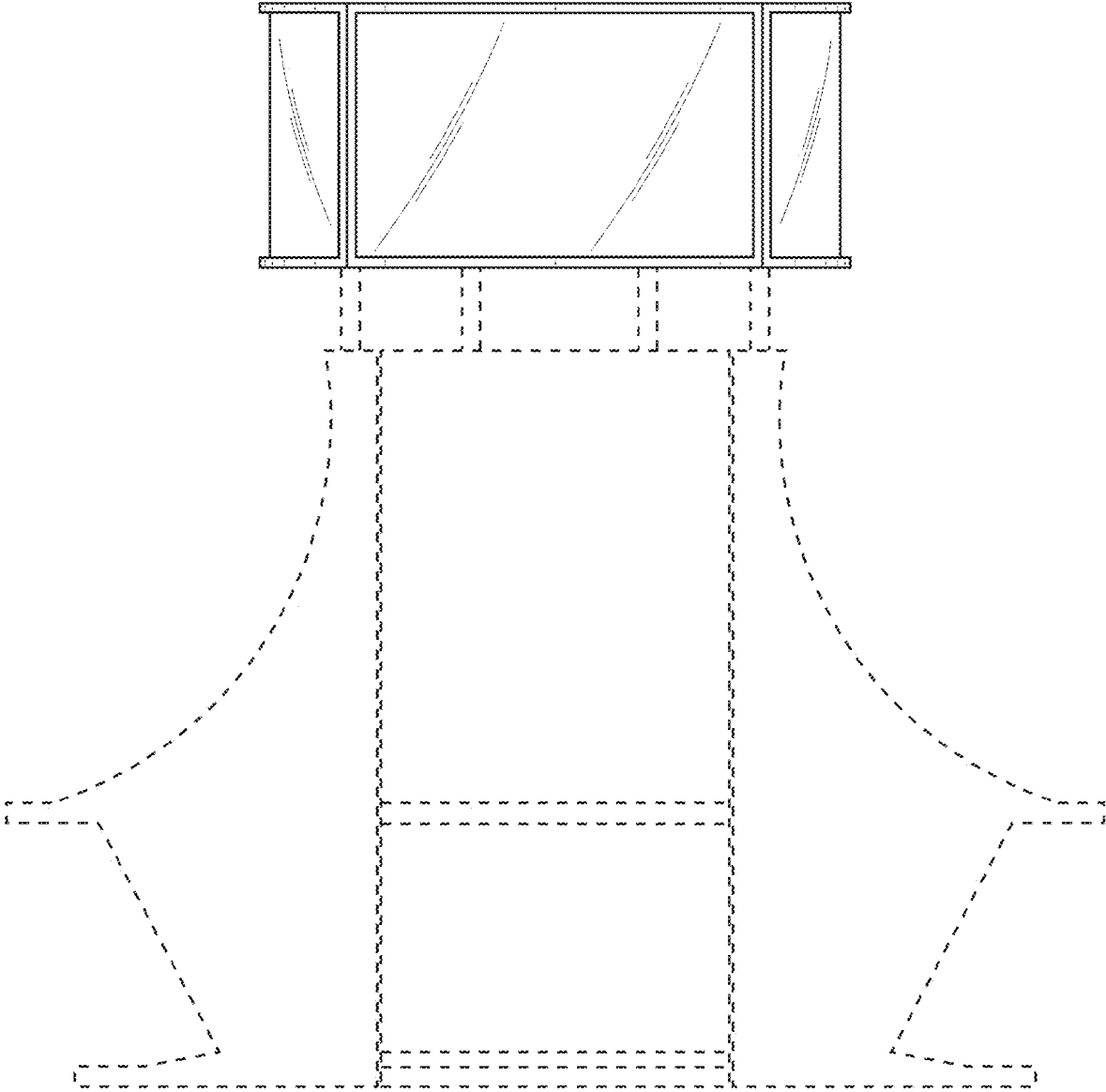

FIG. 2

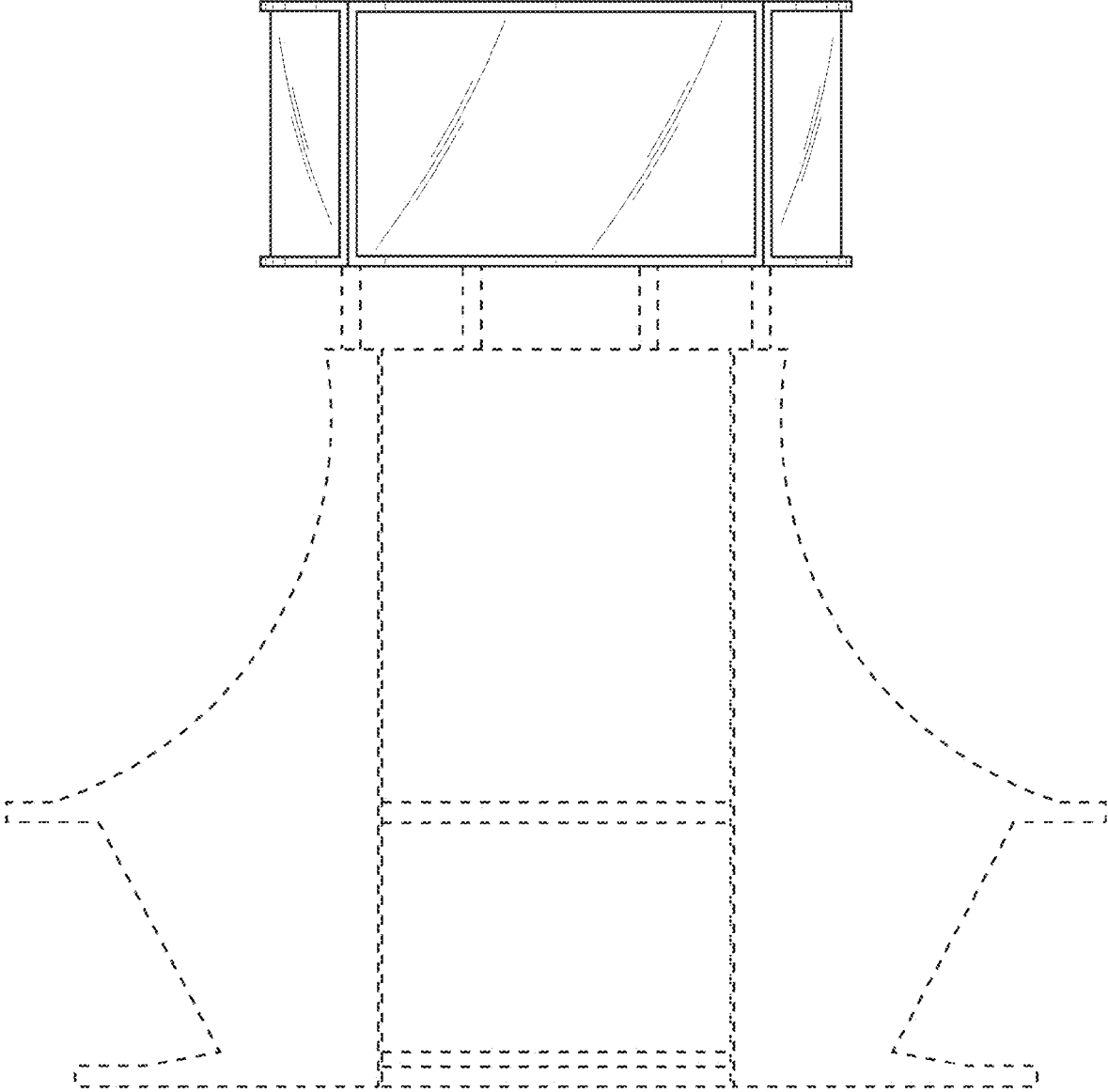

FIG. 3

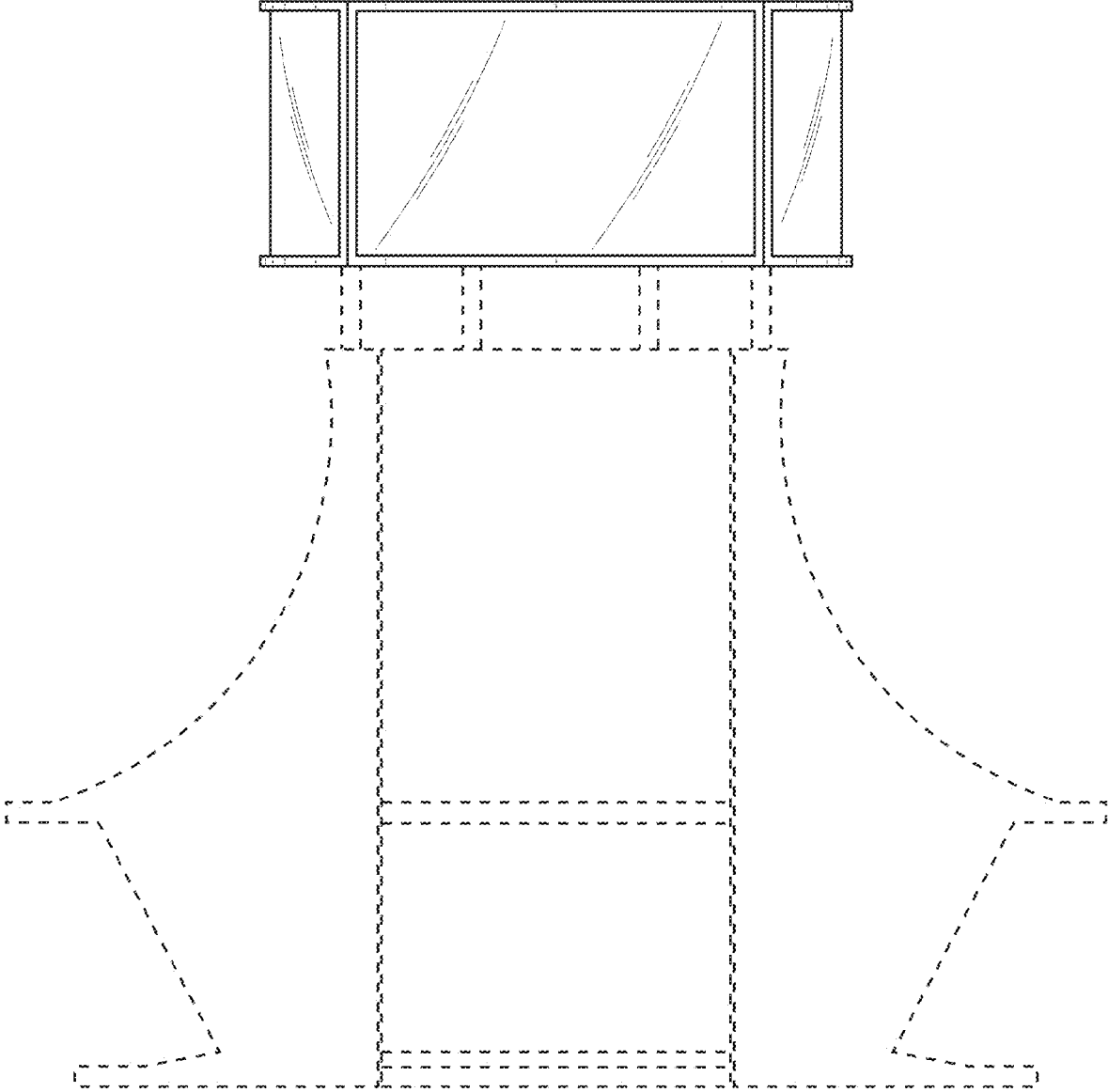

FIG. 4

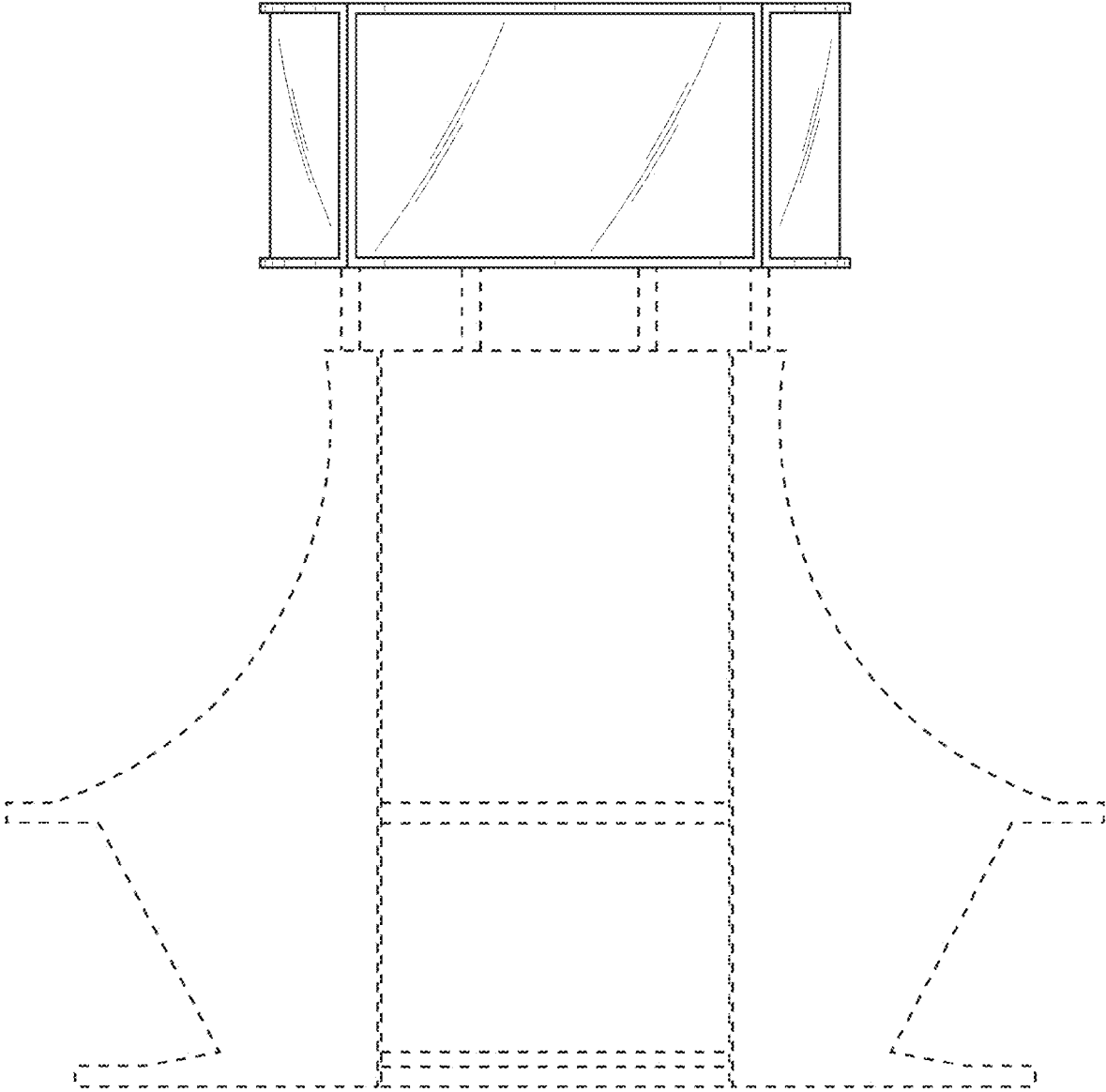

FIG. 5

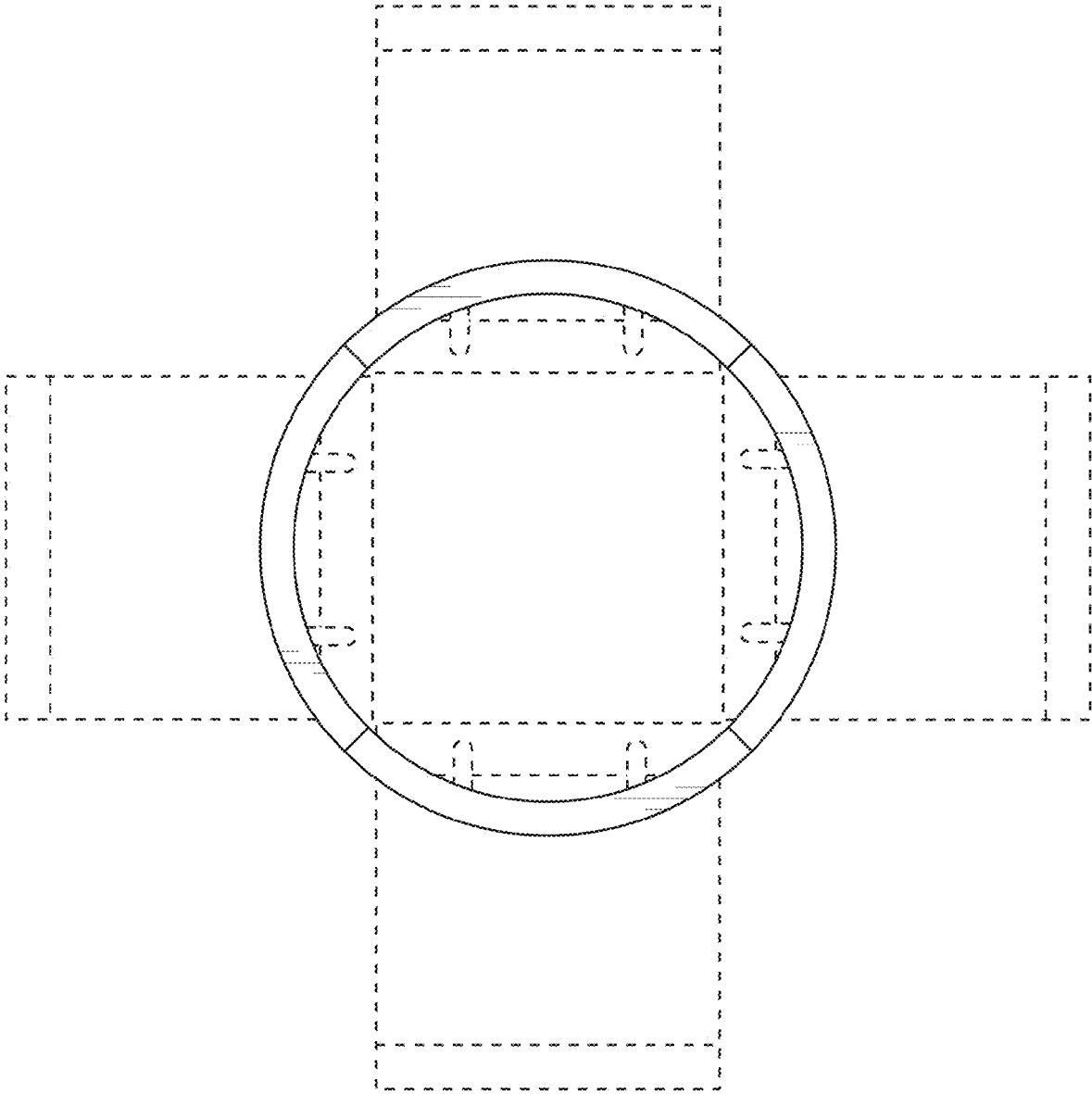

FIG. 6

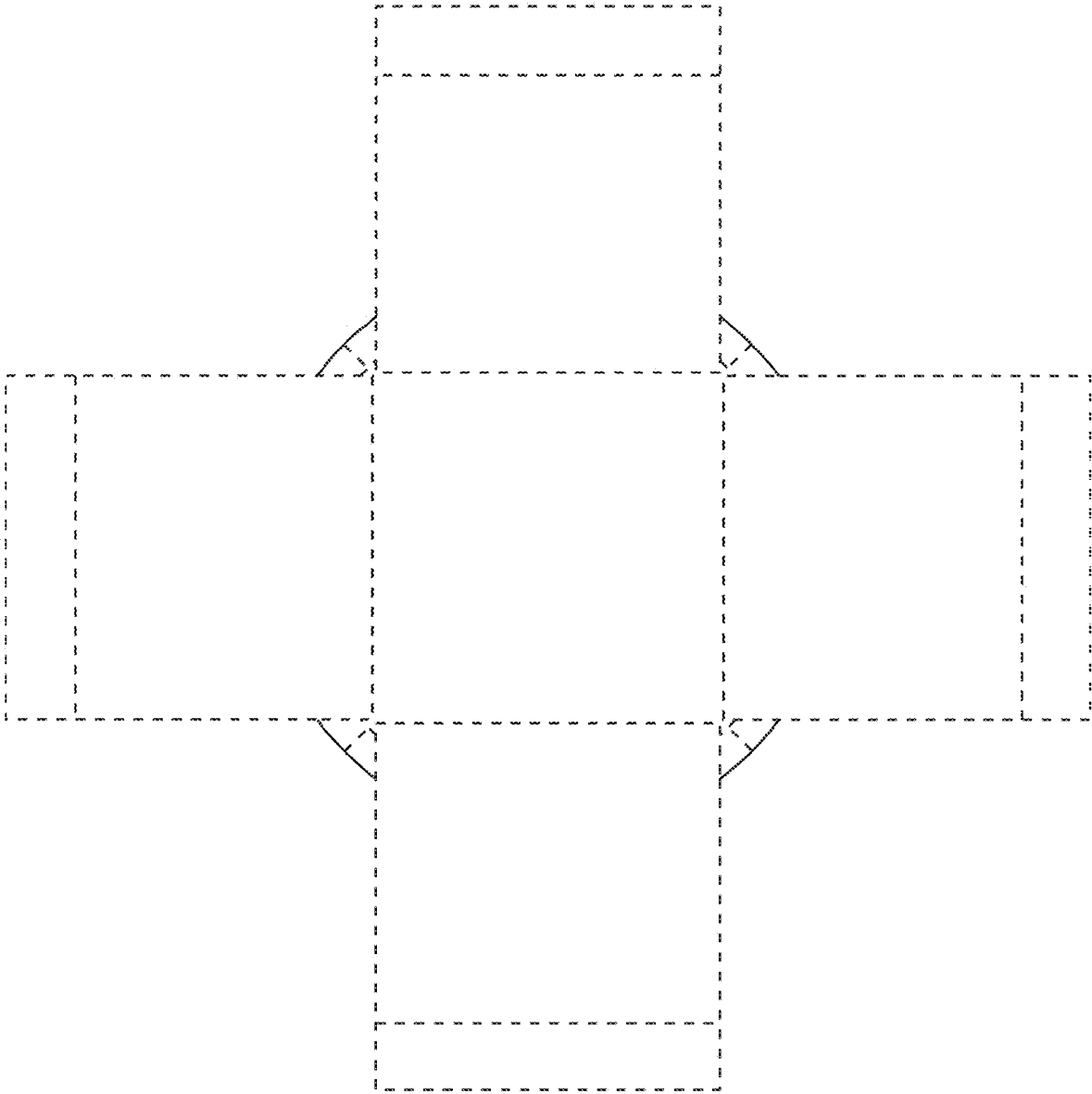

FIG. 7