



(12) **EUROPEAN PATENT APPLICATION**

(43) Date of publication:
07.03.2007 Bulletin 2007/10

(51) Int Cl.:
D06F 39/02 (2006.01)

(21) Application number: **06118805.8**

(22) Date of filing: **11.08.2006**

(84) Designated Contracting States:
AT BE BG CH CY CZ DE DK EE ES FI FR GB GR HU IE IS IT LI LT LU LV MC NL PL PT RO SE SI SK TR
 Designated Extension States:
AL BA HR MK YU

(72) Inventors:
 • **Yang, Yoon Seok**
Gwanak-Gu, Seoul (KR)
 • **Roh, Hyoung Hoon**
Yeongtong-Gu, Suwon-Si, Gyeonggi-Do (KR)

(30) Priority: **30.08.2005 KR 20050079899**
08.09.2005 KR 20050083703

(74) Representative: **Zimmer, Franz-Josef Grünecker, Kinkeldey, Stockmair & Schwanhäusser Anwaltssozietät Maximilianstrasse 58 80538 München (DE)**

(71) Applicant: **Samsung Electronics Co., Ltd. Suwon-si 442-742 Gyeonggi-Do (KR)**

(54) **Detergent dispenser for a washing machine**

(57) A detergent supplying apparatus in which bleach or rinse is not supplied by mistake is disclosed. In order to directly discharge water remaining in a siphon cap (61,62) after siphonage, concave steps (64) are formed in the lower side of a siphon cap (61,62) to form a passage between the siphon cap (61,62) and the bot-

tom of liquid detergent storing chamber (44,45). The detergent supplying apparatus includes a siphon cover (60) having a plurality of siphon caps (61,62) and a rib (66) extended from the siphon caps (61,62) by a predetermined length so that incorrect-coupling of the siphon caps (61,62) is prevented.

FIG.3

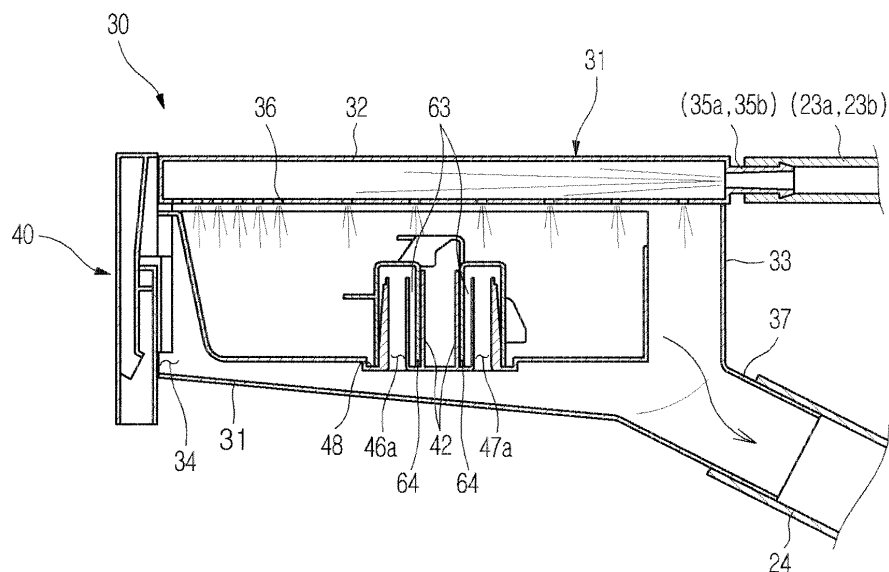

Description

CROSS-REFERENCE TO RELATED APPLICATIONS

BACKGROUND OF THE INVENTION

1. Field of the Invention

[0001] The present invention relates to a detergent supplying apparatus of a clothes washing machine, and more particularly, to a detergent supplying apparatus of a clothes washing machine including a device for preventing siphonage from continuing even when supplying a small quantity of rinse or bleach again after the siphonage in a discharging mode that the bleach and the rinse are discharged due to the siphonage and a device for preventing a siphon pipe from being incorrectly coupled with a siphon cover.

2. Description of the Related Art

[0002] Generally, clothes washing machines are grouped by a drum type clothes washing machine having a drum rotating about a horizontal axis and a pulsator type clothes washing machine, and these clothes washing machines commonly require a device for supplying washing water and detergent for washing clothes.

[0003] Thus, the clothes washing machine includes a detergent supplying device installed to a water line provided between a water supplying valve connected to a water source and a washing tub, and the detergent supplying device includes a detergent reservoir.

[0004] The detergent reservoir has a powder detergent chamber for storing powder detergent, a liquid chamber for storing liquid bleach and rinse such that the bleach and the rinse are inputted into the washing tub due to siphonage using a siphon cap.

[0005] As shown in FIG. 1, the detergent reservoir 1 is partitioned into a powder detergent chamber 2 for storing powder detergent and two liquid detergent chambers 3 for respectively storing liquid bleach and liquid rinse.

[0006] In the upper side of the detergent reservoir 1, guide plates (not shown) in which guide passages suitable for respective storing spaces are formed to guide washing water to be inputted, so that the washing water is supplied into the powder detergent chamber 2 or the liquid detergent chambers 3 in a washing mode and a rinsing mode. Moreover, the washing water supplied into the detergent reservoir 1 is supplied into a washing tub (not shown) via a discharging port provided at a rear side or at a lower side of a detergent reservoir housing (not shown) for accommodating the detergent reservoir 1.

[0007] In the liquid detergent chambers 3, siphon pipes 5 having a predetermined height and communicated with the lower side of the detergent reservoir 1 are covered with siphon caps 4, and the detergent reservoir 1 has concave steps formed at the contact spots contacting the lower sides of the siphon caps 4.

[0008] Thus, in a state of storing a predetermined quantity of the bleach and the rinse in the liquid detergent chambers 3, when the washing water is supplied from the guide plates, the levels of the liquid detergent chambers 3 are gradually increased. When the levels are equal to or greater than the height of the siphon pipes 5, the washing water is continuously discharged to the discharging port (not shown) together with the bleach or the rinse through the siphon pipes 5.

[0009] Such a siphonage is stopped when air is introduced into the siphon caps 4 instead of the washing water, this occurs when the levels are gradually lowered and finally reach the lower sides of the siphon caps 4 due to the interruption of the washing water, this can result in some of the washing water remaining in the siphon caps 4 being discharged into the liquid detergent chambers 3 and causing the siphonage to again occur when the washing water is supplied up to the height of the siphon pipes 5.

[0010] However, if due to the washing water remaining in the siphon caps 4, some of the washing water remains in the detergent reservoir 1, and a clothes washing machine is operated for a long time without cleaning the detergent reservoir 1, buildup may be generated between the siphon caps 4 and the steps so that the washing water remaining in the siphon caps 4 does not flow to the detergent reservoir 1 but remains even when the siphonage is stopped by the siphon caps 4.

[0011] Thus, in this state, when liquid such as the bleach or the rinse is supplied to the liquid detergent chambers 3, the siphonage occurs and the liquid is directly discharged to the discharging port even when the levels do not approach the height of the siphon pipes 5, resulting in the bleach or the rinse being supplied by mistake.

[0012] Moreover, since plural liquid detergent chambers 3 are provided, when a plurality of siphon devices are provided, it is inconvenient to provide the siphon caps 4 corresponding to and coupled with the siphon pipes 5 and to couple the same with the respective siphon pipes 5.

[0013] Due to the above reasons, in a case of providing a plurality of integrated siphon caps, when coupling the siphon caps with the siphon pipes, some of the siphon caps may not be properly coupled with the siphon pipes. In the siphon pipes not coupled with the siphon caps, the siphonage does not occur and it is impossible to supply the rinse or the bleach.

[0014] Further, the upper sides of the siphon caps are blocked by the inner upper sides of the detergent housing so that it is inconvenient to open and close the detergent reservoir.

SUMMARY OF THE INVENTION

[0015] The present invention has been made in view of the above-mentioned problems, and an aspect of the invention is to provide a detergent supplying apparatus

in which bleach or rinse is not supplied by mistake.

[0016] It is another aspect of the present invention to provide a detergent supplying apparatus including a structure for preventing a siphon cap from being incorrectly coupled by mistake.

[0017] In accordance with one aspect, the present invention provides a detergent supplying apparatus of a clothes washing machine including a detergent reservoir with a liquid detergent storing chamber for storing a liquid detergent, including a siphon pipe provided in the liquid detergent storing chamber and having a predetermined height, a siphon cap for covering the siphon pipe and having at least one concave step, and a passage formed between the concave step and the bottom of the liquid detergent storing chamber and communicating the inside with the outside of the siphon cap.

[0018] The minimal number of concave steps may be two and the concave steps may be spaced apart from each other.

[0019] Moreover, a height difference between the uppermost end of the concave step and the lowermost end of the siphon cap is 2 mm to 7 mm.

[0020] The bottom of the liquid detergent storing chamber has a concave step formed in the part adjacent to the lower outer circumference of the siphon cap.

[0021] In accordance with another aspect, the present invention provides a detergent supplying apparatus of a clothes washing machine including a detergent reservoir housing, a detergent reservoir provided in the detergent reservoir housing and having a plurality of liquid detergent storing chambers partitioned by a partition, siphon pipes provided in the liquid detergent storing chambers, a siphon cover including a plurality of siphon caps coupled with the siphon pipes to perform siphonage, and a rib formed in the siphon caps and extended by a predetermined length to prevent incorrect-coupling of the siphon caps.

[0022] The siphon caps may further include an extending part extended from a side thereof by a predetermined length, and the rib may be formed in the extending part.

[0023] Moreover, a level indicator is formed in the outer circumference of the siphon cap to indicate a proper supplying quantity of the detergent.

[0024] Additional aspects and/or advantages of the invention will be set forth in part in the description which follows and, in part, will be apparent from the description, or may be learned by practice of the invention.

BRIEF DESCRIPTION OF THE DRAWINGS

[0025] These and/or other aspects and advantages of the invention will become apparent and more readily appreciated from the following description of the embodiments, taken in conjunction with the accompanying drawings in which:

FIG. 1 is an exploded perspective view illustrating a detergent reservoir and siphon caps of a convention-

al detergent supplying apparatus;

FIG. 2 is a perspective view illustrating a clothes washing machine employing a detergent supplying apparatus according to an embodiment of the present invention;

FIG. 3 is a sectional view illustrating the detergent supplying apparatus of a clothes washing machine according to the embodiment of the present invention;

FIG. 4 is a perspective view illustrating an assembly of a detergent reservoir and a siphon cap of the detergent supplying apparatus according to the embodiment of the present invention;

FIG. 5 is a perspective view illustrating a siphon cover of the detergent supplying apparatus according to the embodiment of the present invention; and

FIG. 6 is a perspective view illustrating an assembly of a detergent reservoir and a siphon cap of the detergent supplying apparatus according to the embodiment of the present invention.

DETAILED DESCRIPTION OF THE PREFERRED EMBODIMENTS

[0026] Reference will now be made in detail to the embodiments of the present invention, examples of which are illustrated in the accompanying drawings. The embodiments are described below to explain the present invention by referring to the figures.

[0027] It should be noticed that a detergent supplying apparatus according to the present invention can be applied to both drum type and pulsator type clothes washing machines and for the convenience of illustration, a detergent supplying apparatus applied to the drum type clothes washing machine only will be described.

[0028] A drum type clothes washing machine, as shown in FIG. 2, includes a cylindrical water tub 11 installed in a main body 10 to accommodate washing water and a cylindrical washing tub 12 installed to rotate in the water tub 11 and having dehydrating holes formed in a wall thereof. In the lower side of the water tub 11, a driving motor 13 is installed so that the washing tub 12 is rotated in the water tub 11 forward and backward to perform the process of washing, rinse, and dehydration. Moreover, the water tub 11 and the washing tub 12 have respective openings formed in the front sides of the main body 10 enabling a user to put in and take out laundry in the front of the main body 10, and a door 14 is installed in the front of the main body 10 to open and close the openings.

[0029] Moreover, in the upper side of the water tub 11, a water supplying device 20 and a detergent supplying apparatus 30 are respectively installed to supply washing water into the water tub 11 and detergent during the water supplying process. In the lower side of the water tub 11, a drainage 16 including a drain pipe 16a and a discharge pump 16b is installed to drain the washing water from the water tub 11 after the washing process.

[0030] The water supplying device 20 is connected to

an external water supply hose (not shown) and includes a plurality of water supply valves 21 and 22 for controlling water supply, a plurality of water supply pipes 23a and 23b for connecting the water supply valves 21 and 22 to the detergent supplying apparatus 30, and a connection pipe 24 for guiding the washing water from the detergent supplying apparatus 30 into the water tub 11.

[0031] The detergent supplying apparatus 30, as shown in FIG. 3, includes a box-shaped detergent reservoir housing 31 having a front opening 34 and a detergent reservoir 40 detachably installed in the detergent reservoir housing 31 through the front opening 34. The detergent supplying apparatus 30 is installed in the upper front side of the main body 10 such that the detergent reservoir 40 can be opened and closed like a drawer at the exterior of the main body 10.

[0032] The detergent reservoir housing 31 has a space formed therein to accommodate the detergent reservoir 40, and includes a front-and-top-opened lower case 33 and an upper case 32 coupled with the upper side of the lower case 33 to cover the opened upper side of the lower case 33.

[0033] The upper case 32 has an inner space and a plurality of introducing ports 35a and 35b, formed in the rear side, to which the respective water supply pipes 23a and 23b are connected such that the washing water is supplied into the upper case 32. In the bottom of the upper case 32, a plurality of water dispensing holes 36 are formed such that the washing water introduced into the upper case 32 can be dispensed to the upper side of the detergent reservoir 40.

[0034] Moreover, the lower case 33 has a discharge pipe 37 provided in the rear side of the lower case 33 communicated with the connection pipe 24 such that the washing water introduced into the water dispensing holes 36 of the upper case 32 and the detergent in the detergent reservoir 40 are supplied into the water tub 11, and a downwardly inclined bottom for enabling the washing water in the lower case 33 to easily flow to the discharge pipe 37.

[0035] The detergent reservoir 40, as shown in FIG. 4, has an opened upper side and detergent storing chambers 43, 44, and 45 partitioned by partitions 41 and 42 into which detergent can be supplied by type.

[0036] The first partition 41 has a predetermined thickness such that a locking protrusion 41 a is formed in the upper side thereof to couple the detergent reservoir 40 with the detergent reservoir housing 31. To this end, a thickness increasing part 41 b for increasing the thickness of the first partition 41 is provided in the vicinity of the second partition 42.

[0037] The detergent reservoir 40 is partitioned into a powder detergent storing chamber 43 for storing powder detergent and liquid detergent storing chambers 44 and 45 for storing liquid detergent such as bleach or rinse. The powder detergent storing chamber 43 has a bottom downwardly inclined from the front side to the rear side 43a.

[0038] Moreover, the liquid detergent storing chambers 44 and 45 are spaces partitioned into two chambers by the second partition 42 to store the bleach and the rinse and respectively include siphon pipes 46 and 47 of a predetermined height to discharge the liquid detergent with the washing water through the lower side of the detergent reservoir 40 due to siphonage.

[0039] The siphon pipes 46 and 47 have hollow cylindrical shapes upwardly protruded from the bottom of the detergent storing chambers 44 and 45, through which the liquid detergent is supplied, to form internal passages 46a and 47a. The siphon pipes 46 and 47 may be provided at positions adjacent to the second partition 42 for partitioning the liquid detergent storing chambers 44 and 45.

[0040] In the siphon pipes 46 and 47, the upper sides communicate with the lower side of the detergent reservoir 40, the upper and lower sides of the siphon pipes 46 and 47 are completely covered with the siphon caps 61 and 62, the lower sides of the siphon caps 61 and 62 contact the lower side of the detergent reservoir 40, the bottom of the liquid detergent storing chambers 44 and 45 such that the upper sides of the siphon pipes 46 and 47 are spaced apart from the upper sides of the siphon caps 61 and 62.

[0041] The lower sides of the siphon caps 46 have steps 64 upwardly concaved from parts contacting the bottoms of the liquid detergent storing chambers 44 and 45 so that passages are formed between the steps 64 and the bottoms of the liquid detergent storing chambers 44 and 45 to communicate the insides of the siphon caps 61 and 62 with the outsides thereof.

[0042] Due to the steps 64, there is a height different between the uppermost ends of the steps 64 of the siphon caps 61 and 62 and the lowermost ends of the siphon caps 61 and 62 contacting the bottoms. When the height difference is large, the sectional area of the passages is increased.

[0043] However, since the point where the siphonage is rapidly stopped corresponds to the increased height, much of the quantity of washing water remains in the liquid detergent storing chambers 44 and 45. On the contrary, when the height difference is small, the passages may be blocked by buildup, so that the problem that occurred in the conventional apparatus cannot be solved.

[0044] Thus, the height difference is equal to or greater than 2 mm to prevent the passages from being blocked due to buildup, and preferably does not exceed 7 mm to allow minimal washing water to remain.

[0045] Moreover, at a part of the bottom adjacent to the lower outer circumferences of the siphon caps 61 and 62, a concave step 48 is formed to minimize the quantity of the washing water remaining after the siphonage.

[0046] The siphon caps 61 and 62 corresponding to the liquid detergent storing chambers are integrally formed with the siphon cover 60.

[0047] The siphon cover 60, as shown in FIG. 4, is integrally formed with the siphon caps 61 and 62 to be

coupled with the siphon pipes 46 and 47 in the liquid detergent storing chambers 44 and 45 such that the second partition 42 is inserted into a space between the siphon caps 61 and 62.

[0048] In the siphon cover 60 employed in the detergent supplying apparatus according to the embodiment of the present invention, a rib 66 is protruded vertically and extended from the outer circumference of the first siphon cap 61. The length of the rib 66 is greater than the distance between the siphon pipes 46 and 47 and the second partition 42. An extending part 67 may extend from the outer circumference of the first siphon cap 61 at a predetermined height in parallel relation to the second partition 42, and the rib 66 may be perpendicular to the extending part 67.

[0049] The upper end of the extending part 67 serves as a level indicator 67a for indicating a proper level where the liquid detergent is supplied to the user. In the outer circumference of the second siphon cap 62, a level indicator 62a is also protruded horizontally.

[0050] In the detergent supplying apparatus 30 according to the embodiment of the present invention, when the second siphon cap 62 is coupled with the siphon protrusion 47, a part of the extending part 67 of the first siphon cap 61 is blocked by the thickness increasing part 41 b of the first partition 41, resulting in preventing incorrect-coupling. Moreover, when the first siphon cap 61 is coupled with the second siphon pipe 46, the lower end of the rib 66 of the first siphon cap 61 is blocked by the upper end of the second partition 42, resulting in preventing incorrect-coupling.

[0051] Hereinafter, another embodiment of the present invention will be described with reference to FIG. 6. The same components as the above preferred embodiment will be omitted and identical numerals are assigned to similar components.

[0052] In a detergent reservoir 40 according to another preferred embodiment of the present invention, the first partition 41 includes a step 41 c having an increased width and formed in a side of the first partition 41 and a locking protrusion 41 a formed in the upper side of the step 41 c.

[0053] In the outer circumferences of the first and second siphon caps 61 and 62, ribs 68a and 68b protrude vertically therefrom and extend by a predetermined length. The protruded length of the ribs 68a and 68b is greater than the distance between the siphon pipes 46 and 47 and the second partition 42. The first and second siphon caps 61 and 62 may also have level indicators 69a and 69b protruded horizontally from the outer circumferences thereof.

[0054] In the detergent supplying apparatus 30 according to another embodiment of the present invention, when the second siphon cap 62 is coupled with the first siphon pipe 47, the rib 68b of the second siphon cap 62 is blocked by the upper end of the second partition 42, resulting in preventing incorrect-coupling. When the first siphon cap 61 is coupled with the second siphon pipe

46, the rib 68a of the first siphon cap 61 is blocked by the upper end of the second partition 42, resulting in preventing incorrect-coupling.

[0055] Hereinafter, the detergent supply and the washing water supply in a clothes washing machine employing the detergent supplying apparatus according to the preferred embodiments of the present invention will be described.

[0056] After inputting the liquid detergent into the liquid detergent storing chambers 44 and 45 if necessary, the user pushes the detergent reservoir 40 into the detergent supplying apparatus 30. Then, in the liquid detergent storing chambers 44 and 45, the siphonage occurs until the level exceeds the height of the siphon pipes 46 and 47.

[0057] Thus, the liquid detergent must be supplied to the proper level corresponding to the level indicators 62a and 67a such that the liquid detergent does not exceed the height of the siphon pipes 46 and 47.

[0058] After pushing the detergent reservoir 40 in, when the clothes washing machine is driven and the washing water is supplied, the washing water supplied through the water supply valves 21 and 22 (See FIG. 2) is supplied into the detergent supplying apparatus 30 through the water supply pipes 23a and 23b and the introducing ports 35a and 35b.

[0059] The washing water supplied into the detergent reservoir 30 is injected to the upper sides of the detergent storing chambers 43, 44, and 45 of the detergent reservoir 40 through the water dispensing holes 36 of the upper case 32.

[0060] At that time, since the level of the liquid such as the detergent and the washing water supplied into the liquid detergent storing chambers 44 and 45 is higher than the upper ends of the siphon pipes 46 and 47, the liquid starts to be discharged through the internal passages 46a and 47a.

[0061] Next, after a predetermined time has lapsed, when the water supply valves 21 and 22 are closed and the supply of the washing water is stopped, the level of the detergent reservoir 40 is gradually decreased, and when the level is lowered to the uppermost end of the concave step 64, air is introduced into the siphon caps 61 and 62.

[0062] Due to this, the levels of the siphon caps 61 and 62 lower and inner pressure of the siphon caps 61 and 62 becomes atmospheric pressure so that the liquid in the siphon caps 61 and 62 is discharged into the liquid detergent storing chambers out of the siphon caps 61 and 62.

[0063] As described above, in the detergent supplying apparatus according to the embodiments of the present invention, the bottoms of the siphon caps 61 and 62 have the concave steps 64 to form the passages.

[0064] Thus, although the detergent reservoir 40 is not washed for a long time, since the insides of the siphon caps 61 and 62 maintain the depressed state after the siphonage, the locking phenomenon in that the liquid re-

mains in the siphon caps 61 and 62 does not occur.

[0065] Moreover, since the liquid is discharged into the liquid detergent storing chambers 44 and 45 and the siphonage occurs before the level reaches a critical level where the siphonage occurs, the liquid detergent is prevented from incorrect-supplying.

[0066] Moreover, the rib 66 is provided to the siphon caps 61 and 62 to prevent the incorrect-coupling of the siphon cover 60 so that the liquid detergent can be smoothly supplied and the detergent reservoir 40 is also smoothly opened and closed.

[0067] Although a few embodiments of the present invention have been shown and described, it would be appreciated by those skilled in the art that changes may be made in this embodiment without departing from the principles and spirit of the invention, the scope of which is defined in the claims and their equivalents.

Claims

1. A detergent supplying apparatus of a clothes washing machine including a detergent reservoir with a liquid detergent storing chamber for storing a liquid detergent, comprising:

a siphon pipe provided in the liquid detergent storing chamber and having a predetermined height;

a siphon cap for covering the siphon pipe and having at least one concave step; and
a passage formed between the concave step and the bottom of the liquid detergent storing chamber and communicating the inside with the outside of the siphon cap.

2. The detergent supplying apparatus of a clothes washing machine according to claim 1, wherein the minimal number of concave steps is two and the concave steps are spaced apart from each other.

3. The detergent supplying apparatus of a clothes washing machine according to claim 1, wherein a height difference between the uppermost end of the concave step and the lowermost end of the siphon cap is 2 mm to 7 mm.

4. The detergent supplying apparatus of a clothes washing machine according to claim 1, wherein the bottom of the liquid detergent storing chamber has a concave step formed in the part adjacent to the lower outer circumference of the siphon cap.

5. A detergent supplying apparatus of a clothes washing machine comprising:

a detergent reservoir housing;
a detergent reservoir provided in the detergent

reservoir housing and having a plurality of liquid detergent storing chambers partitioned by a partition;

siphon pipes provided in the liquid detergent storing chambers;

a siphon cover including a plurality of siphon caps coupled with the siphon pipes to perform siphonage; and

a rib formed in the siphon caps and extended by a predetermined length to prevent incorrect-coupling of the siphon caps.

6. The detergent supplying apparatus of a clothes washing machine according to claim 5, wherein the siphon caps further include an extending part extended from a side thereof by a predetermined length, and the rib is formed in the extending part.

7. The detergent supplying apparatus of a clothes washing machine according to claim 5, further comprising a level indicator formed in the outer circumference of the siphon cap to indicate a proper supplying quantity of the detergent.

8. The detergent supplying apparatus of a clothes washing machine according to claim 5, wherein in the lower ends of the siphon caps, at least one concave step is formed.

9. The detergent supplying apparatus of a clothes washing machine according to claim 5, wherein in the bottom of the liquid detergent storing chambers, a concave step is formed in the part adjacent to the outer circumferences of the siphon caps.

10. The detergent supplying apparatus of a clothes washing machine according to claim 9, wherein a height difference between the uppermost end of the concave step and the lowermost end of the siphon cap is 2 mm to 7 mm.

FIG.1

(PRIOR ART)

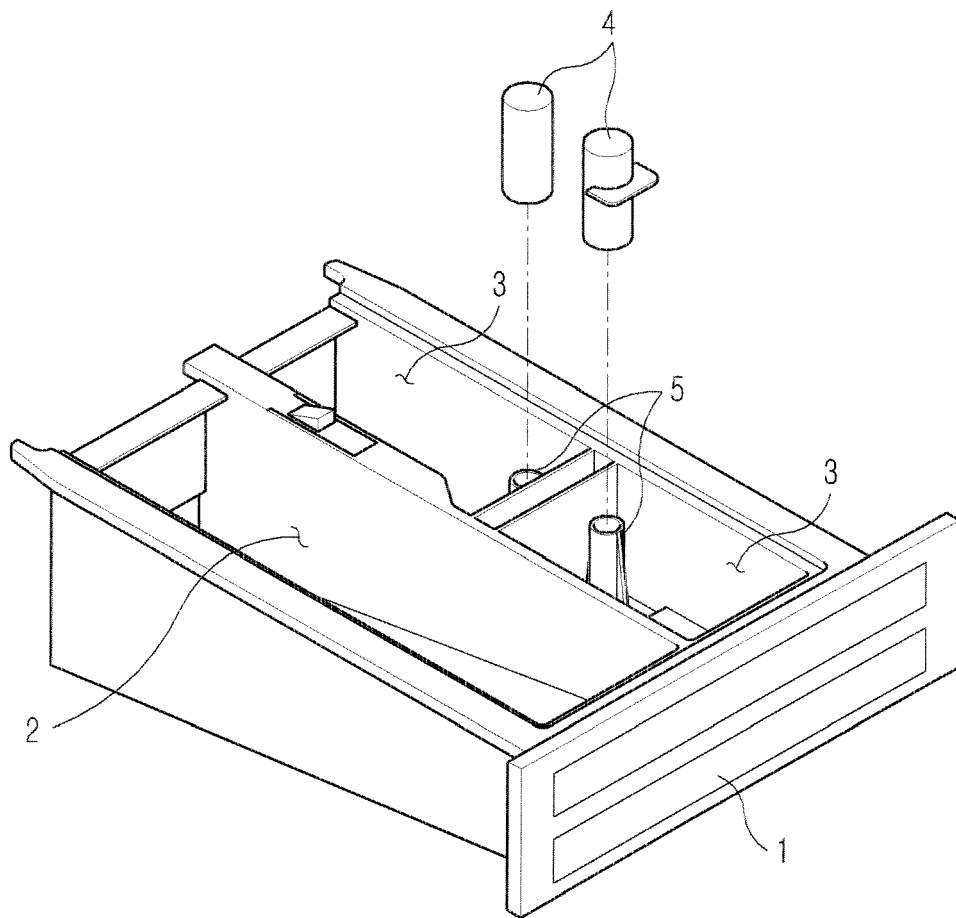

FIG.2

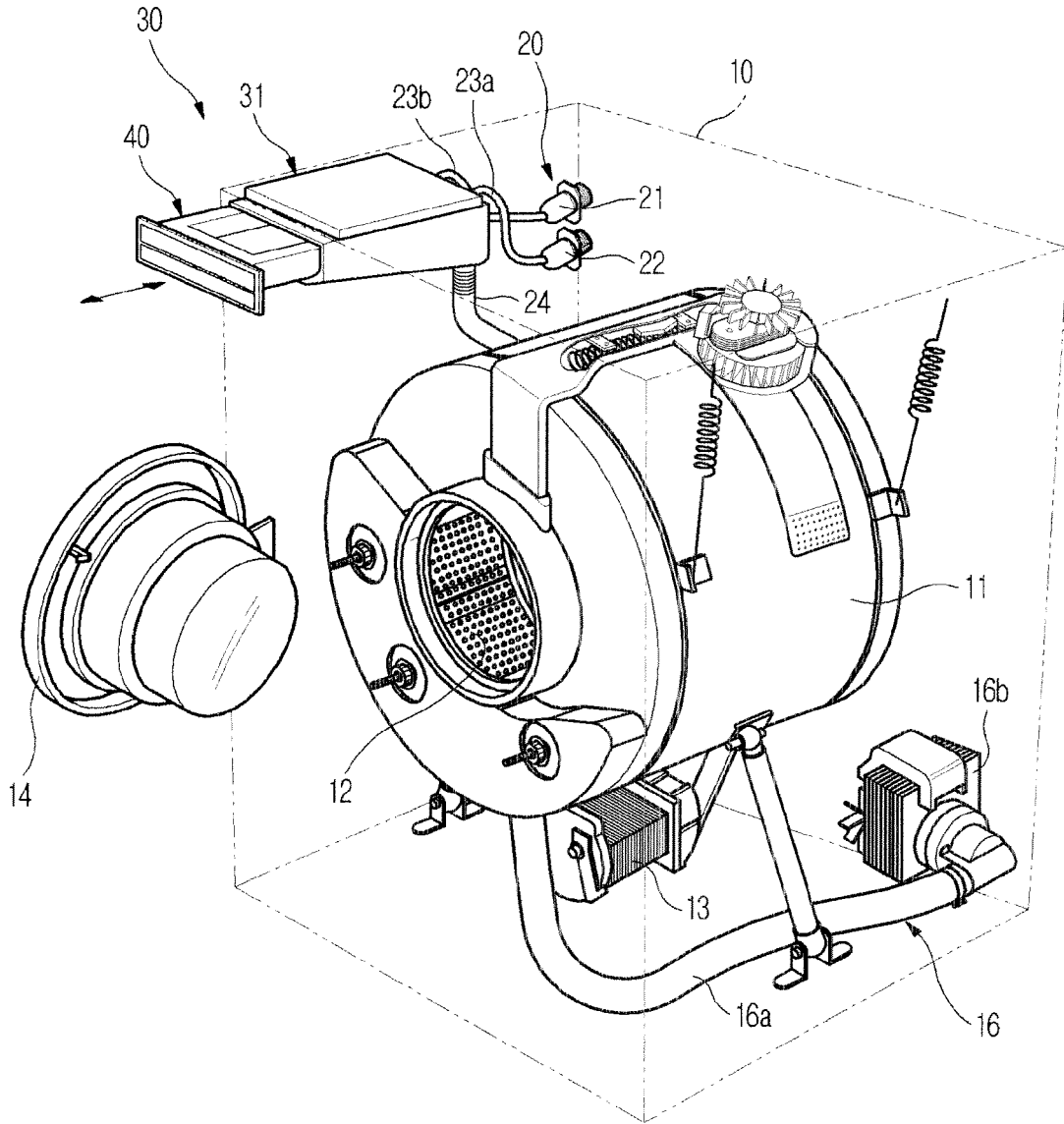

FIG.3

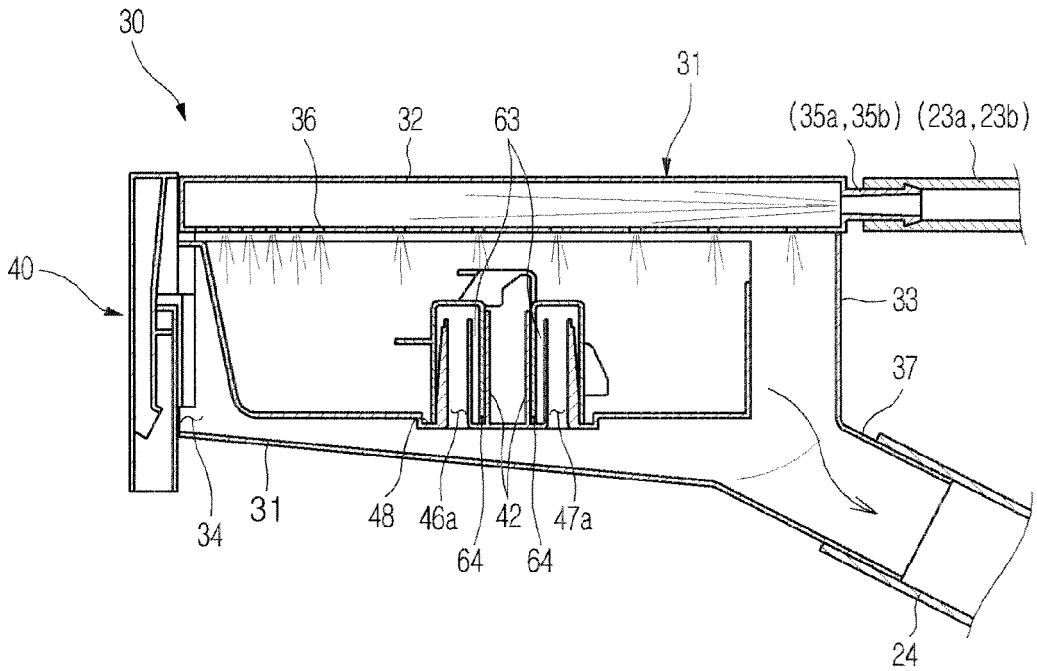

FIG.4

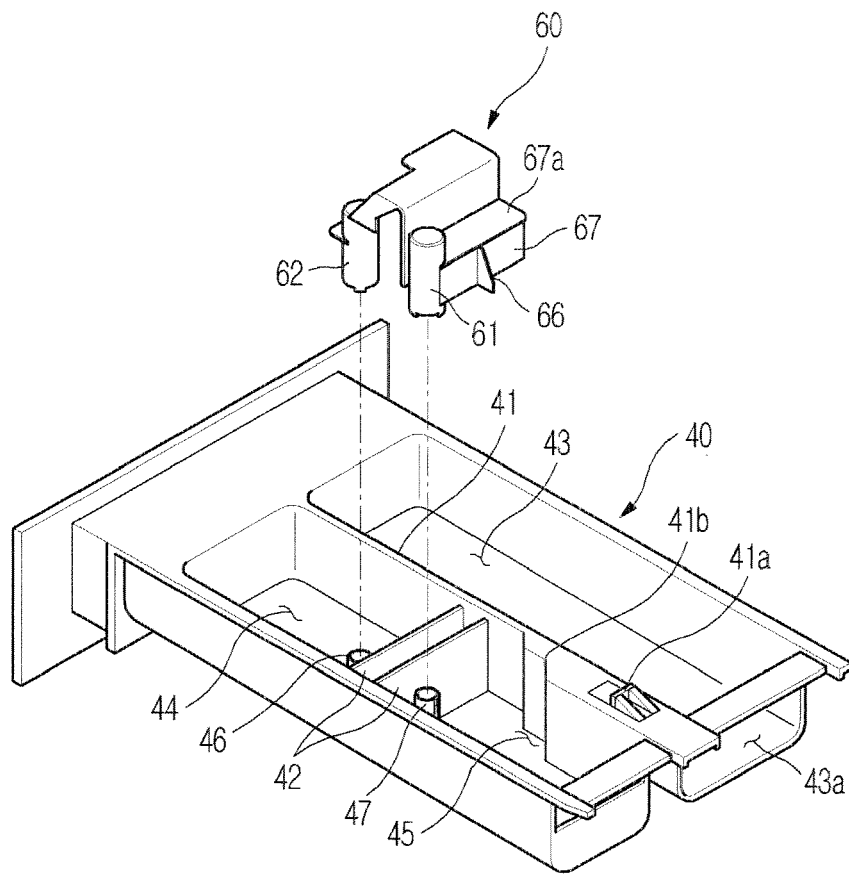

FIG.5

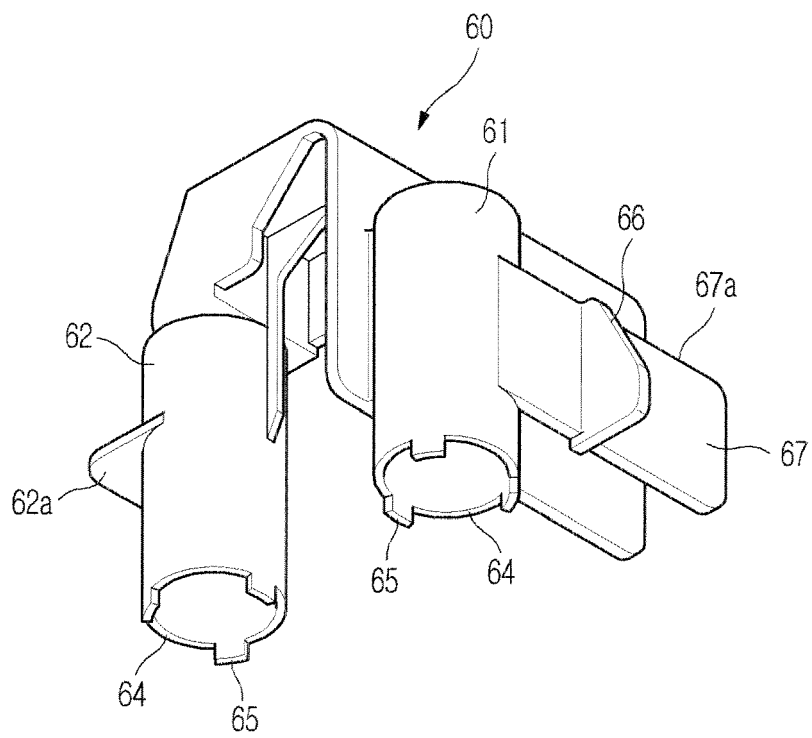
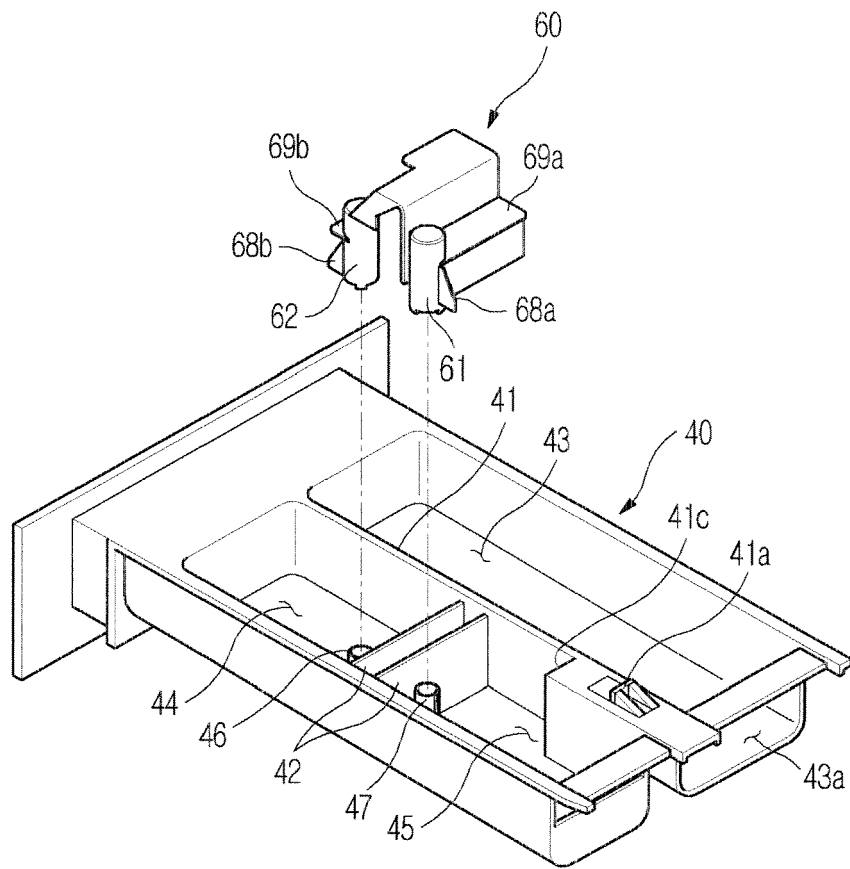

FIG.6



**ANNEX TO THE EUROPEAN SEARCH REPORT
ON EUROPEAN PATENT APPLICATION NO.**

EP 06 11 8805

This annex lists the patent family members relating to the patent documents cited in the above-mentioned European search report. The members are as contained in the European Patent Office EDP file on
The European Patent Office is in no way liable for these particulars which are merely given for the purpose of information.

15-11-2006

Patent document cited in search report		Publication date	Patent family member(s)	Publication date
FR 2837504	A3	26-09-2003	DE 20304263 U1	10-07-2003
			ES 1055463 U1	01-12-2003
			GB 2386613 A	24-09-2003
			IT PN20020017 U1	19-09-2003
			US 2004011089 A1	22-01-2004

US 2003145633	A1	07-08-2003	CA 2417070 A1	06-08-2003

GB 2187764	A	16-09-1987	DE 3608619 A1	17-09-1987
			FR 2597517 A1	23-10-1987
			IT 1204921 B	10-03-1989

DE 20211363	U1	26-09-2002	DE 20208189 U1	08-08-2002
