

(12) PATENT
(19) AUSTRALIAN PATENT OFFICE

(11) Application No. AU 199719887 B2
(10) Patent No. 726277

(54) Title
Functional barrier in oxygen scavenging film

(51)⁶ International Patent Classification(s)
C08K 005/00 B65D 081/24
B32B 027/18

(21) Application No: 199719887 (22) Application Date: 1997.03.07

(87) WIPO No: W097/32925

(30) Priority Data

| (31) Number | (32) Date | (33) Country |
|-------------|------------|--------------|
| 60/013013 | 1996.03.07 | US |
| 813752 | 1997.03.07 | US |

(43) Publication Date : 1997.09.22
(43) Publication Journal Date : 1997.11.20
(44) Accepted Journal Date : 2000.11.02

(71) Applicant(s)
Cryovac, Inc.

(72) Inventor(s)
Donald A. Bansleben; Michael L. Becraft; Thomas A.
Blinka ; Nathanael R. Miranda; Drew V. Speer

(74) Agent/Attorney
DAVIES COLLISON CAVE,1 Little Collins Street,MELBOURNE VIC 3000

(56) Related Art
EP 698563
AU 36764/95
EP 638487

OPI DATE 22/09/97 APPLN. ID 19887/97
AOJP DATE 20/11/97 PCT NUMBER PCT/US97/03528



INT.

AU9719887

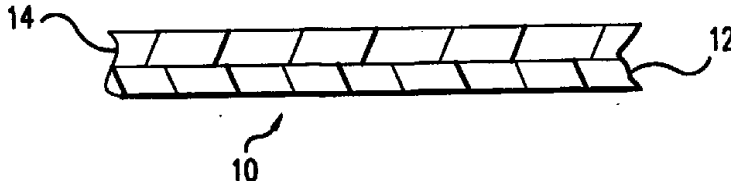
| | | |
|---|--|---|
| (51) International Patent Classification 6: C08K 5/00, B32B 27/18, B65D 81/24 | | (11) International Publication Number: WO 97/32925 |
| (21) International Application Number: PCT/US97/03528 | | (43) International Publication Date: 12 September 1997 (12.09.97) |
| (22) International Filing Date: 7 March 1997 (07.03.97) | | (81) Designated States: AL, AM, AT, AU, AZ, BB, BG, BR, BY, CA, CH, CN, CZ, DE, DK, EE, ES, FI, GB, GE, HU, IL, IS, JP, KE, KG, KP, KR, KZ, LK, LR, LS, LT, LU, LV, MD, MG, MK, MN, MW, MX, NO, NZ, PL, PT, RO, RU, SD, SE, SG, SI, SK, TJ, TM, TR, TT, UA, UG, UZ, VN, ARIPO patent (GH, KE, LS, MW, SD, SZ, UG), Eurasian patent (AM, AZ, BY, KG, KZ, MD, RU, TJ, TM), European patent (AT, BE, CH, DE, DK, ES, FI, FR, GB, GR, IE, IT, LU, MC, NL, PT, SE), OAPI patent (BF, BJ, CF, CG, CI, CM, GA, GN, ML, MR, NE, SN, TD, TG). |
| (30) Priority Data: 60/013,013 7 March 1996 (07.03.96) US 813,752 7 March 1997 (07.03.97) US | | |
| (71) Applicant: W. R. GRACE & CO. CONN. [US/US]; 1114 Avenue of the Americas, New York, NY 10036-7794 (US). | | |
| (72) Inventors: BANSLEBEN, Donald, A.; 10616 Harpoon Hill, Columbia, MD 21044 (US). BECRAFT, Michael, L.; 10406 Popkins Court, Woodstock, MD 21163 (US). BLINKA, Thomas, A.; 11604 Wave Lap Way, Columbia, MD 21044 (US). MIRANDA, Nathanael, R.; 1876-C Robinwood Road, Gastonia, NC 28054 (US). SPEER, Drew, V.; 6229 Slender Sky, Columbia, MD 21044 (US). | | |
| (74) Agents: BURLESON, David, G. et al.; 100 Rogers Bridge Road, P.O. Box 464, Duncan, SC 29334 (US). | | Published <i>With international search report. Before the expiration of the time limit for amending the claims and to be republished in the event of the receipt of amendments.</i> |
| (73) Title: FUNCTIONAL BARRIER IN OXYGEN SCAVENGING FILM | | (71) CRYOVAC, INC. P.O. Box 464 Duncan SC 29334-0464 United States of America |
|  | | |
| (57) Abstract An article of manufacture includes an oxygen scavenger, and a polymer selected from the group consisting of a polymer derived from a propylene monomer, a polymer derived from a methyl acrylate monomer, a polymer derived from a butyl acrylate monomer, a polymer derived from a methacrylic acid monomer, polyethylene terephthalate glycol (PETG), amorphous nylon, ionomer, and a polymeric blend including a polyterpene. The article can be in the form of e.g. a film, a polymeric functional barrier coating on an oxygen scavenging lacquer, or a gasket. A package can be made from this article for containing an oxygen-sensitive article such as food. The described polymers reduce or block the migration of odor causing by-products of an oxygen scavenging process. A method of making an article of manufacture having reduced migration of by-products of an oxygen scavenging reaction includes providing an article including an oxygen scavenger and the above-described polymer; and exposing the article to actinic radiation. | | |

see folio 3

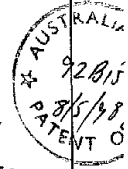

FUNCTIONAL BARRIER IN OXYGEN SCAVENGING FILM

5

FIELD OF THE INVENTION

The invention generally relates to an article and method for scavenging by-products of an oxygen scavenging reaction.

10 BACKGROUND OF THE INVENTION

It is well known that limiting the exposure of oxygen-sensitive products to oxygen maintains and enhances the quality and "shelf-life" of the product. In the food packaging industry, several means for regulating oxygen exposure have already been developed.

15 These means include modified atmosphere packaging (MAP) for modifying the interior environment of a package; gas flushing; vacuum packaging; vacuum packaging combined with the use of oxygen barrier packaging materials; etc. Oxygen barrier films and laminates reduce or retard oxygen permeation from the outside environment into the package interior.

20 Another method currently being used is through "active packaging." The inclusion of oxygen scavengers within the cavity or interior of the package is one form of active packaging. Typically, such oxygen scavengers are in the form of sachets which contain a composition which scavenges the oxygen through chemical reactions. One type of sachet contains iron compositions which oxidize. Another type of sachet contains unsaturated fatty acid salts on a particulate adsorbent. Yet another type of sachet contains a metal/polyamine complex as disclosed in WO88/06641.

25
30 One disadvantage of sachets is the need for additional packaging operations to add the sachet to each package. A further disadvantage



arising from some sachets is that certain atmospheric conditions (e.g., high humidity, low CO₂ level) in the package are required in order for scavenging to occur at an adequate rate.

Another means for limiting the exposure to oxygen involves incorporating an oxygen scavenger into the packaging structure itself. This achieves a more uniform scavenging effect throughout the package. This may be especially important where there is restricted air circulation inside the package. In addition, such incorporation can provide a means of intercepting and scavenging oxygen as it passes through the walls of the package (herein referred to as an "active oxygen barrier"), thereby maintaining the lowest possible oxygen level throughout the package.

One attempt to prepare an oxygen-scavenging wall involves the incorporation of inorganic powders and/or salts. However, incorporation of these powders and/or salts causes degradation of the wall's transparency and mechanical properties such as tear strength. In addition, these compounds can lead to processing difficulties, especially in the fabrication of thin films, or thin layers within a film structure. Even further, the scavenging rates for walls containing these compounds are unsuitable for some commercial oxygen-scavenging applications, e.g. such as those in which sachets are employed.

Other efforts have been directed to incorporating a metal catalyst-polyamide oxygen scavenging system into the package wall. However, this system does not exhibit oxygen scavenging at a commercially feasible rate.

Oxygen scavengers suitable for commercial use in films of the present invention are disclosed in U.S. Patent No. 5,350,622, and a method of initiating oxygen scavenging generally is disclosed in U.S. Patent No 5,211,875. Both applications are incorporated herein by reference in their entirety. According to U.S. Patent No. 5,350,622, oxygen scavengers are made of an ethylenically unsaturated hydrocarbon and

transition metal catalyst. The preferred ethylenically unsaturated hydrocarbon may be either substituted or unsubstituted. As defined herein, an unsubstituted ethylenically unsaturated hydrocarbon is any compound which possesses at least one aliphatic carbon-carbon double bond and comprises 100% by weight carbon and hydrogen. A substituted ethylenically unsaturated hydrocarbon is defined herein as an ethylenically unsaturated hydrocarbon which possesses at least one aliphatic carbon-carbon double bond and comprises about 50% - 99% by weight carbon and hydrogen. Preferable substituted or unsubstituted ethylenically unsaturated hydrocarbons are those having two or more ethylenically unsaturated groups per molecule. More preferably, it is a polymeric compound having three or more ethylenically unsaturated groups and a molecular weight equal to or greater than 1,000 weight average molecular weight.

Preferred examples of unsubstituted ethylenically unsaturated hydrocarbons include, but are not limited to, diene polymers such as polyisoprene, (e.g., trans-polyisoprene) and copolymers thereof, cis and trans 1,4-polybutadiene, 1,2-polybutadienes, (which are defined as those polybutadienes possessing greater than or equal to 50% 1,2 microstructure), and copolymers thereof, such as styrene-butadiene copolymer. Such hydrocarbons also include polymeric compounds such as polypentenamer, polyoctenamer, and other polymers prepared by cyclic olefin metathesis; diene oligomers such as squalene; and polymers or copolymers with unsaturation derived from dicyclopentadiene, norbornadiene, 5-ethylidene-2-norbornene, 5-vinyl-2-norbornene, 4-vinylcyclohexene, 1,7-octadiene, or other monomers containing more than one carbon-carbon double bond (conjugated or non-conjugated).

Preferred substituted ethylenically unsaturated hydrocarbons include, but are not limited to, those with oxygen-containing moieties, such as esters, carboxylic acids, aldehydes, ethers, ketones, alcohols, peroxides, and/or hydroperoxides. Specific examples of such hydro-

carbons include, but are not limited to, condensation polymers such as polyesters derived from monomers containing carbon-carbon double bonds, and unsaturated fatty acids such as oleic, ricinoleic, dehydrated ricinoleic, and linoleic acids and derivatives thereof, e.g. esters. Such hydrocarbons also include polymers or copolymers derived from (meth)allyl (meth)acrylates. Suitable oxygen scavenging polymers can be made by trans-esterification. Such polymers are disclosed in WO 95/02616, incorporated herein by reference as if set forth in full. The composition used may also comprise a mixture of two or more of the substituted or unsubstituted ethylenically unsaturated hydrocarbons described above. While a weight average molecular weight of 1,000 or more is preferred, an ethylenically unsaturated hydrocarbon having a lower molecular weight is usable, provided it is blended with a film-forming polymer or blend of polymers.

As will also be evident, ethylenically unsaturated hydrocarbons which are appropriate for forming solid transparent layers at room temperature are preferred for scavenging oxygen in the packaging articles described above. For most applications where transparency is necessary, a layer which allows at least 50% transmission of visible light is preferred.

When making transparent oxygen-scavenging layers according to this invention, 1,2-polybutadiene is especially preferred for use at room temperature. For instance, 1,2-polybutadiene can exhibit transparency, mechanical properties and processing characteristics similar to those of polyethylene. In addition, this polymer is found to retain its transparency and mechanical integrity even after most or all of its oxygen uptake capacity has been consumed, and even when little or no diluent resin is present. Even further, 1,2-polybutadiene exhibits a relatively high oxygen uptake capacity and, once it has begun to scavenge, it exhibits a relatively high scavenging rate as well.

When oxygen scavenging at low temperatures is desired, 1,4-polybutadiene, and copolymers of styrene with butadiene, and styrene with isoprene are especially preferred. Such compositions are disclosed in U.S. Patent No. 5,310,497 issued to Speer et al. on May 10, 1994
5 and incorporated herein by reference as if set forth in full. In many cases it may be desirable to blend the aforementioned polymers with a polymer or copolymer of ethylene.

Other oxygen scavengers which can be used in connection with this invention are disclosed in U.S. Patent Nos. 5, 075,362 (Hofeldt et al.), 5, 106,886 (Hofeldt et al.), 5, 204,389 (Hofeldt et al.), and
10 5, 227,411 (Hofeldt et al.), all incorporated by reference herein in their entirety. These oxygen scavengers include ascorbates or isoascorbates or mixtures thereof with each other or with a sulfite, often sodium sulfite.

15 Still other oxygen scavengers which can be used in connection with this invention are disclosed in PCT patent publications WO 91/17044 (Zapata Industries), WO94/09084 (Aquanautics Corporation), and WO88/06641, all incorporated by reference herein in their entirety. These oxygen scavengers include an ascorbate with a transition
20 metal catalyst, the catalyst being a simple metal or salt or a compound, complex or chelate of the transition metal; a transition metal complex or chelate of a polycarboxylic or salicylic acid, optionally with a reducing agent such as ascorbate, where the transition metal complex or chelate acts primarily as an oxygen scavenging composition; and a
25 transition metal complex or chelate of a polyamine.

Yet other oxygen scavengers which can be used in connection with this invention are disclosed in PCT patent publication WO 94/12590 (Commonwealth Scientific and Industrial Research Organisation), incorporated by reference herein in its entirety. These oxygen
30 scavengers include at least one reducible organic compound which is reduced under predetermined conditions, the reduced form of the com-

pound being oxidizable by molecular oxygen, wherein the reduction and/or subsequent oxidation of the organic compound occurs independent of the presence of a transition metal catalyst. The reducible organic compound is preferably a quinone, a photoreducible dye, or a carbonyl compound which has absorbance in the UV spectrum.

Sulfites, alkali metal salts of sulfites, and tannins, are also contemplated as oxygen scavenging compounds.

As indicated above, the ethylenically unsaturated hydrocarbon is combined with a transition metal catalyst. While not being bound by any particular theory, the inventors observe that suitable metal catalysts are those which can readily interconvert between at least two oxidation states. See Sheldon, R. A.; Kochi, J. K.; "Metal-Catalyzed Oxidations of Organic Compounds" Academic Press, New York 1981.

Preferably, the catalyst is in the form of a transition metal salt, with the metal selected from the first, second or third transition series of the Periodic Table. Suitable metals include, but are not limited to, manganese II or III, iron II or III, cobalt II or III, nickel II or III, copper I or II, rhodium II, III or IV, and ruthenium II or III. The oxidation state of the metal when introduced is not necessarily that of the active form. The metal is preferably iron, nickel or copper, more preferably manganese and most preferably cobalt. Suitable counterions for the metal include, but are not limited to, chloride, acetate, stearate, palmitate, caprylate, linoleate, tallate, 2-ethylhexanoate, neodecanoate, oleate or naphthenate. Particularly preferable salts include cobalt (II) 2-ethylhexanoate, cobalt stearate, and cobalt (II) neodecanoate. The metal salt may also be an ionomer, in which case a polymeric counterion is employed. Such ionomers are well known in the art.

The ethylenically unsaturated hydrocarbon and transition metal catalyst can be further combined with one or more polymeric diluents, such as thermoplastic polymers which are typically used to form film

layers in plastic packaging articles. In the manufacture of certain packaging articles well known thermosets can also be used as the polymeric diluent.

5 Polymers which can be used as the diluent include, but are not limited to, polyethylene terephthalate (PET), polyethylene, low or very low density polyethylene, ultra-low density polyethylene, linear low density polyethylene, polypropylene, polyvinyl chloride, polystyrene, and ethylene copolymers such as ethylene-vinyl acetate, ethylene-alkyl (meth)acrylates, ethylene-(meth)acrylic acid and ethylene-(meth)acrylic acid ionomers. Blends of different diluents may also be used. However, 10 as indicated above, the selection of the polymeric diluent largely depends on the article to be manufactured and the end use. Such selection factors are well known in the art.

Further additives can also be included in the composition to impart 15 properties desired for the particular article being manufactured. Such additives include, but are not necessarily limited to, fillers, pigments, dyestuffs, antioxidants, stabilizers, processing aids, plasticizers, fire retardants, anti-fog agents, etc.

The mixing of the components listed above is preferably accomplished by melt-blending at a temperature in the range of 50°C to 20 300°C. However alternatives such as the use of a solvent followed by evaporation may also be employed. The blending may immediately precede the formation of the finished article or preform or precede the formation of a feedstock or masterbatch for later use in the production 25 of finished packaging articles.

Although these technologies offers great potential in packaging applications, it has been found that oxygen scavenging structures can sometimes generate reaction byproducts which can affect the taste and smell of the packaged material (i.e. organoleptic properties), or raise 30 food regulatory issues. These by-products can include organic acids, aldehydes, ketones, and the like.

This problem can be minimized by the use of polymeric functional barriers. A polymeric functional barrier is a polymeric material which acts as a selective barrier to by-products from the oxygen scavenging reaction, but is not itself a significant barrier to oxygen. The functional barriers are selected from the group consisting of one or more of the following: polymers comprising a propylene monomer, polymers comprising a methyl acrylate monomer, polymers comprising a methacrylic acid monomer, polyethylene terephthalate glycol (PETG), amorphous nylon, ionomer, and polymeric blends comprising a polyterpene. Such functional barrier polyterpene blends are disclosed in WO 94/06626 to Balloni *et al.* which is incorporated her by reference as if set forth in full. Examples include but are not limited to polypropylene, propylene/ethylene copolymers, ethylene/methacrylic acid copolymer, and ethylene/methyl acrylate copolymer. The functional barrier polymer(s) may further be blended with another polymer to modify the oxygen permeability as required by some applications. The functional barriers can be incorporated into one or more layers of a multi-layer film or container which includes an oxygen scavenging layer. However, one of ordinary skill in the art will readily recognize that the present invention is applicable to any oxygen scavenging system that produces by-products such as organic acids, aldehydes, ketones, and the like.

Polymeric functional barriers for oxygen scavenging applications are disclosed in WO 96/08371 to Ching *et al.* which is incorporated here as if set forth in full. The materials in this case are high glass transition temperature (T_g) glassy polymers such as Polyethylene terephthalate (PET) and nylon 6 that are preferably further oriented. Conversely, the inventors of this application have surprisingly found certain low T_g polymers and their blends to be useful functional barrier materials.

In certain applications of oxygen scavenging, it is desirable to achieve rapid scavenging of oxygen from the headspace of a package. In order to accomplish this, the functional barrier layer(s) must be relatively highly permeable to oxygen while maintaining functional barrier attributes (i.e., preventing the migration of small organic molecules). In these cases, it is preferred that the oxygen permeability of the functional barrier be greater than about 3,000 cc O₂ per m² per day per atmosphere (tested at 1 mil thick and at 25 °C), preferably greater than 5,000, more preferably greater than 8,000 and most preferably greater than 10,000 cc O₂ per m² per day per atmosphere (tested at 1 mil thick and at 25 °C at ASTM D3985). The higher the permeability of the layer(s) interposed between the oxygen scavenger and the headspace of the package, the faster that oxygen can be scavenged from the headspace. The exact oxygen permeability required for a given application can readily be determined through experimentation by one skilled in the art. Higher oxygen permeability can readily be accomplished by blending the functional barrier polymer with any polymer which has a substantially higher oxygen permeability. Useful polymers for blending with functional barrier polymers include but are not limited to polymers and copolymers of alkyl acrylates, especially ethylene/butyl acrylate, ethylene/vinyl acetate copolymers, and the like.

DEFINITIONS

"Film" herein means a film, laminate, sheet, web, coating, or the like which can be used to package a product.

"Oxygen scavenger" (OS) and the like herein means a composition, article or the like which consumes, depletes or reacts with oxygen from a given environment.

"Actinic radiation" herein means any form of radiation, such as ultraviolet radiation, or electron beam radiation, as disclosed in U.S.

Patent No. 5,211,875 (Speer et al.) incorporated herein by reference in its entirety.

"Functional barrier" herein means a polymeric material which acts as a selective barrier to by-products from the oxygen scavenging reaction but not to oxygen.

5 "LLDPE" herein means linear low density polyethylene, which is an ethylene/ alpha-olefin copolymer.

"EVOH" herein means ethylene/vinyl alcohol copolymer.

"EVA" herein means ethylene/vinyl acetate copolymer.

"Polymer" and the like herein means a homopolymer, but also copolymers thereof, including bispolymers, terpolymers, etc.

10 "Ethylene/alpha-olefin copolymer" and the like herein means such heterogeneous materials as linear low density polyethylene (LLDPE), linear medium density polyethylene (LMDPE) and very low and ultra low density polyethylene (VLDPE and ULDPE); and homogeneous polymers such as metallocene catalyzed polymers such as EXACT (TM) materials supplied by
15 Exxon, and TAFMER (TM) materials supplied by Mitsui Petrochemical Corporation. These materials generally include copolymers of ethylene with one or more comonomers selected from C₄ to C₁₀ alpha-olefins such as butene-1 (i.e., 1-butene), hexene-1, octene-1, etc. in which the molecules of the copolymers comprise long chains with relatively few side
20 chain branches or cross-linked structures. This molecular structure is to be contrasted with conventional low or medium density polyethylenes which are more highly branched than their respective counterparts. Other ethylene/a-olefin copolymers, such as the long chain branched homogeneous ethylene/a-olefin copolymers available from the Dow
25 Chemical Company, known as AFFINITY (TM) resins, are also included as another type of ethylene alpha-olefin copolymer useful in the present invention. It is further contemplated that single-site catalyzed polyethylenes, known as Versipol™ (DuPont), will be useful in the present invention.

30 As used herein, the term "polyamide" refers to polymers having amide linkages along the molecular chain, and preferably to synthetic

polyamides such as nylons. Furthermore, such term encompasses both polymers comprising repeating units derived from monomers, such as caprolactam, which polymerize to form a polyamide, as well as copolymers of two more amide monomers, including nylon terpolymers, also referred to generally as "copolyamides" herein.

5

SUMMARY OF THE INVENTION

In one aspect of the invention, an article of manufacture in the form of a film, comprising:

- (a) a first layer comprising an oxygen barrier;
- 10 (b) a second layer comprising an oxygen scavenger; and
- (c) a third layer comprising a polymer selected from the group consisting of polyethylene terephthalate glycol (PETG) and amorphous nylon.

Preferably, the oxygen scavenger comprises a material selected from the group consisting of:

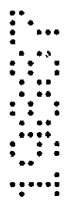

- 15 i) an oxidizable compound and a transition metal catalyst,
- ii) an ethylenically unsaturated hydrocarbon and a transition metal catalyst,
- iii) ascorbate,
- iv) isoascorbate,
- v) sulfite,
- 20 vi) ascorbate with a transition metal catalyst, the catalyst comprising a simple metal or salt, or a compound, complex or chelate of the transition metal,
- vii) a transition metal complex or chelate of a polycarboxylic acid, salicylic acid, or polyamine,
- viii) a reduced form of a quinone, a photoreducible dye, or a carbonyl compound
- 25 which has absorbance in the UV spectrum, and tannin.

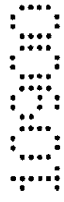

In a second aspect of the invention, a package comprises an oxygen sensitive article, and a container into which the oxygen sensitive article is disposed, the container including a layer comprising an oxygen scavenger, a layer comprising a polymer selected from the group consisting of polyethylene terephthalate glycol (PETG), and amorphous nylon, and a layer comprising an oxygen barrier.

30



In a third aspect of the invention, a method of making an article having reduced migration of by-products of an oxygen scavenging reaction comprises providing an article comprising an oxygen scavenger, and a layer comprising a polymer selected from the group consisting of polyethylene terephthalate glycol (PETG) and amorphous nylon, ionomer, and a layer comprising an oxygen barrier; and exposing the article to actinic radiation.

In a further aspect of the invention, there is provided an article in the form of a polymeric functional barrier coating on an oxygen scavenging lacquer, wherein the polymeric functional barrier coating comprises a polymer selected from the group consisting of polyethylene terephthalate glycol (PETG) and amorphous nylon.

In an even further aspect of the invention, there is provided an article in the form of a gasket, wherein the gasket comprises an oxygen scavenger, and a polymer selected from the group consisting of polyethylene terephthalate glycol (PETG) and amorphous nylon.

BRIEF DESCRIPTION OF THE DRAWINGS

The invention may be further understood, by way of example only, with reference to the drawings wherein Figure 1 is a schematic cross-section of a film which is capable of being used in accordance with a film of the present invention; Figures 2 through 5 are schematic cross-sections of various embodiments of a film in accordance with the present invention; and Figures 6 through 11 graphically illustrate acetaldehyde concentration with time for various films in accordance with the invention, and comparative examples.

DESCRIPTION OF THE PREFERRED EMBODIMENTS

The invention can be used to make various articles of manufacture, compounds, compositions of matter, coatings, etc. Three preferred forms are: sealing compounds of gaskets; a polymeric functional barrier coating on an oxygen scavenging lacquer; and flexible films, all useful in packaging of food and non-food products.

It is known to use sealing compounds in the manufacture of gaskets for the rigid container market. Large, wide diameter gaskets are typically made using a liquid plastisol.



- 12A -

This plastisol is a highly viscous, liquid suspension of polymer particles in a plasticizer. In the manufacture of metal or plastic caps, lids, and the like, this liquid plastisol is applied to the annulus of a container such as a jar, and the container with the applied plastisol is "fluxed" in an oven to solidify the plastisol into a gasket. The result is a gasket formed
5 around the annulus of the container.

Smaller gaskets are typically made for use in beer crowns in bottles. A polymer melt is applied by cold molding to the entire inner surface of the crown. Both PVC and other polymers are used in this application.

1
2
3
4
5

6
7
8
9
10



Discs for plastic caps are typically made by taking a ribbon of gasket material and making discs, and inserting the discs into the plastic cap.

In all of these applications, the use of an oxygen scavenger and a
5 polymeric functional barrier beneficially provides removal of oxygen from the interior environment of the container, while controlling undesirable by-products of the oxygen scavenging reaction.

Thus, a gasket includes an oxygen scavenger, and a polymeric functional barrier. The gasket adheres a metal or plastic lid or closure
10 to a rigid or semi-rigid container, thus sealing the lid or closure to the container.

A lacquer for cans or other rigid or semi-rigid containers can contain an oxygen scavenging material, e.g. of the type described herein, and be coated with a polymeric functional barrier.

15 Film of the invention can be made by any conventional means, including coextrusion, lamination, extrusion coating, solution coating, or corona bonding, and then optionally irradiated and/or oriented. They can be made heat shrinkable through orientation or tenterframing if desired, at orientation ratios of 1:2 to 1:9 in either or both of the
20 machine and transverse directions. For shrink applications, they can be made to have a free shrink of at least 10%, more preferably at least 20%, most preferably at least 30%, in either or both directions at 90°C. The polymeric functional barrier can be used in more than one layer of the multilayer film. Different polymeric functional barriers can be used
25 in the same film. Although it is preferred that the polymeric functional barrier be used in the film and as a packaging material such that the polymeric functional barrier is disposed closer to the contents of the package, which can be food or any oxygen-sensitive product, than the oxygen scavenger, there may be applications where the polymeric func-
30 tional barrier is disposed "outside of" the oxygen scavenger, such that the oxygen scavenger is disposed closer to the contents of the package

than the polymeric functional barrier. The polymeric functional barrier can also be disposed on both sides of the oxygen scavenger.

Alternatively, the functional barrier, in addition to or instead of the arrangements described elsewhere herein, can be disposed in the same layer or layers as the oxygen scavenging material. Thus, by way of example, any of layers 14, 34, 44, and 54 of the examples and figures can include any suitable percent, by weight of the layer, of the functional barrier. Any suitable polymeric materials can be employed in films containing the functional barrier, and are not limited to those listed herein.

Polymeric functional barriers disclosed herein can thus be used beneficially with and in films and coatings, or absorbed into, or adsorbed onto, a variety of other supports for scavenging or other uses, such as a layer or coating on another object, or as a bottle cap or bottle liner, as an adhesive or non-adhesive insert, sealant, gasket, fibrous mat or other inserts, or as a non-integral component of a rigid, semi-rigid, or flexible container.

Referring to Figure 1, a multilayer film 10 is shown, having layer 12 and layer 14.

Figure 2 shows a multilayer film, in accordance with the present invention, with layers 12, 14, and 16. Layers 12, 14, and 16 are preferably polymeric.

Layer 12 comprises a polymer selected from the group consisting of a polymer derived from a propylene monomer, a polymer derived from a methyl acrylate monomer, a polymer derived from a butyl acrylate monomer, a polymer derived from a methacrylic acid monomer, polyethylene terephthalate glycol (PETG), amorphous nylon, ionomer, and a polymeric blend comprising a polyterpene. These materials can act as a functional barrier to the migration or extraction of by-products of an oxygen scavenging reaction occurring within the film.



Layer 14 comprises an oxygen scavenger, preferably a polymeric oxygen scavenger, more preferably one of the materials described above.

5 Layer 16 comprises an oxygen barrier material, such as ethylene/vinyl alcohol copolymer (EVOH), Saran (vinylidene chloride copolymer), polyester, polyamide, metal, etc.

Figure 3 shows a laminated film in which a three layer film is adhered to a second film. Layers 32, 34, and 36 correspond functionally and compositionally to 12, 14, and 16 respectively of Figure 2, and
10 layer 38 is an intermediate layer which can comprise any polymeric material such as polyolefin, more preferably ethylenic polymers such as ethylene/alpha-olefin and ethylene/unsaturated ester copolymers, more preferably ethylene vinyl acetate copolymer. Layer 31 represents a conventional adhesive such as polyurethane adhesive. Comparative 2
15 in Table 6 exemplifies the laminated film of Figure 3.

Figure 4 shows a laminated film in which a four layer film is adhered to a second film. Layers 42, 44, 46 and 48 correspond functionally and compositionally to layers 32, 34, 36 and 38 respectively of Figure 3. Layer 49 is an innermost heat sealable layer which can
20 comprise any polymeric material such as polyolefin, more preferably ethylenic polymers such as ethylene/alpha-olefin and ethylene/unsaturated ester copolymers, such as ethylene vinyl acetate copolymer. Layer 46 provides oxygen barrier to the film structure, and adheres to layer 48 by means of conventional adhesive 41. This adhesive
25 corresponds to layer 31 of Figure 3, and is shown simply as a thickened line. Examples 2 and 3 of Table 6 exemplify the laminated film of Figure 4.

Figure 5 shows a nine layer film. Example 1 and Comparative 1 in Table 2 exemplify the film of Figure 5.

30 Layer 57 is an abuse-resistant layer useful as an outermost layer of a film when used in a packaging application.

Layers 54 and 56 correspond functionally to layers 14 and 16 respectively of Figures 2 and 3, as well as to layers 44 and 46 respectively of Figure 4.

5 Layers 52, 53, 58 and 59 comprise an adhesive. The adhesive is preferably polymeric, more preferably acid or acid anhydride-grafted polyolefins. In addition, these layers can comprise a polymeric functional barrier of the type described for layer 12.

10 Layer 55 comprises a heat resistant material. This can be any suitable polymeric material, preferably an amide polymer such as nylon 6, or a polyester such as polyethylene terephthalate. Layer 55 can also comprise a polymeric functional barrier of the type described for layer 12.

15 Layer 51 comprises a heat sealable material. This can be any suitable polymeric material, preferably an olefinic polymer such as an ethylenic polymer, more preferably an ethylene/alpha olefin copolymer.

Figures 6 through 11 each illustrate a graph in which the horizontal "x" axis represents time in minutes, and the vertical "y" axis represents the acetaldehyde migration through the examples in units representing the area under the curve of gas chromatograph peak areas.

20 In Figure 6, the curve plotted by the diamond shaped symbol represents the acetaldehyde migration over time through the film of Example 1; the curve plotted by the square shaped symbol represents the acetaldehyde migration over time through the film of Example 2; and the curve plotted by the triangle shaped symbol represents the acetaldehyde migration over time through the film of Example 3.

In like manner to the above:

in Figure 7, the diamond shaped symbol represents Example 4, the square shaped symbol represents Example 5, and the triangle shaped symbol represents Example 6;

30 in Figure 8, the hollow square shaped symbol represents Example 7, the solid (black) square shaped symbol with dotted line repre-

sents Comparative Example 1, the hollow triangle shaped symbol represents Example 8, and the solid (black) triangle shaped symbol with dotted line represents Comparative Example 2;

5 in Figure 9, the square shaped symbol represents Example 9, the triangle shaped symbol represents Example 10, and the dotted line represents Comparative Example 3;

in Figure 10, the square shaped symbol represents Example 11, the triangle shaped symbol represents Example 12, and the dotted line represents Comparative Example 4; and

10 in Figure 11, the diamond shaped symbol represents Example 13, the square shaped symbol represents Example 14, the triangle shaped symbol represents Example 15, the asterisk shaped symbol represents Example 16, and the dotted line represents Comparative Example 5.

15 The invention may be further understood by reference to the examples shown below. Table 1 identifies the materials used in the examples.

TABLE 1

| <u>MATERIAL</u> | <u>TRADENAME</u> | <u>SOURCE</u> | <u>DESCRIPTION</u> |
|-----------------|-----------------------------------|------------------|---|
| PE ₁ | Dowlex™ 2244A | Dow | LLDPE, an ethylene/ 1-octene copolymer with a density of .917 gm/cc |
| PE ₂ | Dowlex 3010 | Dow | LLDPE, an ethylene/ 1-octene copolymer with a density of 0.921 gm/cc |
| PE ₃ | PE 1017 | Chevron | low density polyethylene |
| AB ₁ | 10,075 ACP Syloid™ concentrate | Tecknor Color | 89.8% low density polyethylene (Exxon LD 203.48) + 10% synthetic amorphous silica (Syloid™ 74X6500 from Davison Chemical) + 0.2% calcium stearate |
| EV ₁ | LD 318.92 | Exxon | ethylene vinyl acetate copolymer with 9% vinyl acetate comonomer |

| | | | |
|-------------------|--------------------------------|----------------------|--|
| EV ₂ | PE 1375 | Rexene | ethylene vinyl acetate copolymer with 3% vinyl acetate comonomer |
| EV ₃ | AC-400A | Allied | ethylene vinyl acetate copolymer |
| AD ₁ | Tymor™ 1203 | Morton International | anhydride-grafted LLDPE |
| AD ₂ | Adcote 530 and Coreactant 9L23 | Morton International | mixture of silane, isocyanate, glycol, and alkyl acetate |
| OB ₁ | LC-H101BD | Evalca | ethylene-vinyl alcohol copolymer with 38% ethylene comonomer |
| OS ₁ | Vector 8508-D | Dexco | styrene-butadiene copolymer |
| OS ₂ | RB-830 | JSR | 1,2-polybutadiene |
| OS ₃ | VISTALON™ 3708 | Exxon | ethylene propylene diene terpolymer |
| PP ₁ | Profax 6801 | Himont | polypropylene |
| PP ₂ | Escorene PD3345.E5 | Exxon | polypropylene |
| PEC ₁ | Escorene PD9302.E1 | Exxon | propylene-ethylene copolymer with 3% ethylene comonomer |
| PT ₁ | Piccolyte C135 | Hercules | polyterpene |
| EM ₁ | SP2260 | Chevron | ethylene methyl acrylate copolymer with 24% methyl acrylate comonomer |
| EM ₂ | Bynel E403 | DuPont | adhesive resin based on ethylene-methyl acrylate-methacrylic acid terpolymer |
| EB ₁ | EA-719.009 | Quantum | ethylene-butyl acrylate with 18% butyl acrylate comonomer |
| EB ₂ | Lotryl 30BA02 | Atochem | ethylene-butyl acrylate with 30% butyl acrylate comonomer |
| EMAA ₁ | Nucrel 1202 | DuPont | ethylene-methacrylic acid copolymer with 12% methacrylic acid |
| EAA ₁ | Primacor 1410 | Dow | ethylene-acrylic acid copolymer with 9.5% acrylic acid |
| ION ₁ | DS-3088 | Chevron | ionomer based on ethyl- |

| | | | |
|------------------|---------------------|---------------|---|
| | | | ene-methyl acrylate copolymer |
| ION ₂ | DS-3076 | Chevron | ionomer based on ethylene-methyl acrylate copolymer |
| ION ₃ | SURLYN™1650 | DuPont | ionomer |
| ION ₄ | SURLYN™1707 | DuPont | ionomer |
| PA ₁ | Ultramid™ KR 4407-F | BASF | nylon 6 (polycaprolactam) |
| PA ₂ | Capron™ 7007 | Allied Signal | a blend of 70% nylon 6 and 30% amorphous nylon having hexamethylene diamine, terephthalic acid, and isophthalic acid moieties |
| PA ₃ | 6763 | Eastman | polyethylene terephthalate glycol |
| PI ₁ | benzophenone | Sartomer | photoinitiator |
| PI ₂ | benzoylbiphenyl | | photoinitiator |
| CAT ₁ | cobalt oleate | Shepherd | a transition metal catalyst |
| CAT ₂ | TENCEM™ 170 | OMG | cobalt neodecanoate, a transition metal catalyst |
| F ₁ | 50m-44 Mylar™ | DuPont | saran-coated polyethylene terephthalate film |

Certain materials were blended together for some of the film structures, and these blends are identified as follows:

$$\text{OSB}_1 = 60\% \text{OS}_1 + 38.93\% \text{EV}_1 + 1.06\% \text{CAT}_1 + 0.01\% \text{Irganox 1076}$$

5 (antioxidant)

$$\text{OSB}_2 = 60\% \text{OS}_1 + 39.2\% \text{EV}_1 + 0.5\% \text{EV}_3 + 0.3\% \text{CAT}_2$$

$$\text{OSB}_3 = 76.5\% \text{OS}_2 + 13.5\% \text{OS}_3 + 9.2\% \text{EV}_1 + 0.5\% \text{PI}_1 + 0.3\% \text{CAT}_2$$

$$\text{OSB}_4 = 40\% \text{OS}_1 + 54.83\% \text{EV}_1 + 1.06\% \text{CAT}_1 + 0.10\% \text{PI}_2 + 0.01\% \text{Irganox 1076 (antioxidant)}$$

10 $\text{PEB}_1 = 85\% \text{PE}_1 + 15\% \text{PT}_1$.

$$\text{PEB}_2 = 90\% \text{PE}_2 + 10\% \text{AB}_1$$

$$\text{EVB}_1 = 85\% \text{EV}_1 + 15\% \text{PT}_1$$

$$\text{IONB}_1 = 90\% \text{ION}_3 + 10\% \text{AB}_1$$

$$\text{PPB}_1 = 60\% \text{PP}_2 + 40\% \text{EB}_2$$

PPB₂ = 40% PP₂ + 60% EB₂.

It has been found that oxygen scavenging structures can generate reaction by-products which can affect the taste and smell of the packaged material, or raise food regulatory issues. These by-products include aldehydes, acids, ketones and the like. An aldehyde migration test was developed to identify potential functional barriers. In this test, acetaldehyde was chosen as the model aldehyde compound because it is relatively mobile. The film sample was sandwiched between two halves of a cell with a clamp and two o-rings. Acetaldehyde was introduced to one half of the cell. A gas chromatograph was used to determine the concentration of acetaldehyde which migrated through the film sample and into the other half of the cell. A functional barrier can significantly reduce acetaldehyde migration through the film sample. In Table 2, three monolayer films are disclosed.

15

TABLE 2

| <u>EXAMPLE</u> | <u>STRUCTURE</u> |
|----------------|------------------|
| 1 | PE ₁ |
| 2 | EV ₁ |
| 3 | PP ₁ |

The target (and approximate actual) gauge (in mils) of each monolayer was 2 mils. Acetaldehyde migration through the films are shown in Figure 6. Polypropylene can be considered a functional barrier.

20

In Table 3, three monolayer films are disclosed.

TABLE 3

| <u>EXAMPLE</u> | <u>STRUCTURE</u> |
|----------------|------------------|
| 4 | PP ₁ |
| 5 | PEC ₁ |
| 6 | EB ₁ |

The target (and approximate actual) gauge (in mils) of each monolayer was 2 mils. Acetaldehyde migration through the films are shown in Figure 7. Polypropylene and propylene-ethylene copolymers can be considered functional barriers.

- 5 In Table 4, two monolayer films and two comparative monolayer films are disclosed.

TABLE 4

| <u>EXAMPLE</u> | <u>STRUCTURE</u> |
|----------------|------------------|
| 7 | PEB ₁ |
| COMP 1 | PE ₁ |
| 8 | EVB ₁ |
| COMP 2 | EV ₁ |

- 10 The target (and approximate actual) gauge (in mils) of each monolayer was 2 mils. Acetaldehyde migration through the films are shown in Figure 8. Blending a small amount of polyterpene with another polymer can increase the functional barrier properties of some polymers.

- 15 In Table 5, two coextruded four-layer films in accordance with the invention, and a comparative four-layer film, are disclosed.

TABLE 5

| <u>EXAMPLE</u> | <u>STRUCTURE</u> |
|----------------|---|
| 9 | PE ₁ /EM ₁ /OSB ₁ /EV ₂ |
| 10 | PE ₁ /EM ₂ /OSB ₁ /EV ₂ |
| COMP. 3 | PE ₁ /PE ₁ /OSB ₁ /EV ₂ |

- 20 The target (and approximate actual) gauge (in mils) of each layer of the invention and the comparative structure was:

| layer 1 | layer 2 | layer 3 | layer 4 |
|---------|---------|---------|---------|
| 0.15 | 0.15 | 0.50 | 1.20 |

During the acetaldehyde migration test, the oxygen scavenging reaction was not activated. Acetaldehyde migration through the films are shown in Figure 9. Ethylene-methyl acrylate copolymers and ethylene-methyl acrylate-methacrylic acid terpolymers can be considered functional barriers.

In Table 6, two coextruded four-layer films in accordance with the invention, and a comparative four-layer film, are disclosed.

TABLE 6

| EXAMPLE | STRUCTURE |
|---------|--|
| 11 | PE ₁ /ION ₁ /OSB ₁ /EV ₂ |
| 12 | PE ₁ /ION ₂ /OSB ₁ /EV ₂ |
| COMP. 4 | PE ₁ /PE ₁ /OSB ₁ /EV ₂ |

10

The target (and approximate actual) gauge (in mils) of each layer of the invention and the comparative structure was:

| layer 1 | layer 2 | layer 3 | layer 4 |
|---------|---------|---------|---------|
| 0.15 | 0.15 | 0.50 | 1.20 |

During the acetaldehyde migration test, the oxygen scavenging reaction was not activated. Acetaldehyde migration through the films are shown in Figure 10. Ionomers based on ethylene-methyl acrylate copolymers can be considered functional barriers.

In Table 7, four coextruded three-layer films in accordance with the invention, and a comparative three-layer film, are disclosed.

20

TABLE 7

| EXAMPLE | STRUCTURE |
|---------|--|
| 13 | ION ₃ /OSB ₂ /EV ₂ |
| 14 | ION ₄ /OSB ₂ /EV ₂ |
| 15 | EAA ₁ /OSB ₂ /EV ₂ |
| 16 | EMAA ₁ /OSB ₂ /EV ₂ |

| | |
|---------|--|
| COMP. 5 | PE ₁ /OSB ₂ /EV ₂ |
|---------|--|

The target (and approximate actual) gauge (in mils) of each layer of the invention and the comparative structure was:

| layer 1 | layer 2 | layer 3 |
|---------|---------|---------|
| 0.30 | 0.50 | 1.20 |

- 5 During the acetaldehyde migration test, the oxygen scavenging reaction was not activated. Acetaldehyde migration through the films are shown in Figure 11. Ethylene-methacrylic acid copolymers can be considered functional barriers.

- 10 In Table 8, three nine-layer film structures in accordance with the invention, and a comparative example, are disclosed. These were each made by a coextrusion of the layers.

TABLE 8

| EXAMPLE | STRUCTURE |
|---------|--|
| COMP. 6 | PEB ₂ /AD ₁ /OB ₁ /AD ₁ /OSB ₃ /AD ₁ /PA ₁ /AD ₁ /PEB ₂ |
| 17 | IONB ₁ /AD ₁ /OB ₁ /AD ₁ /OSB ₃ /AD ₁ /PA ₁ /AD ₁ /IONB ₁ |
| 18 | IONB ₁ /AD ₁ /OB ₁ /AD ₁ /OSB ₃ /AD ₁ /PA ₂ /AD ₁ /IONB ₁ |
| 19 | IONB ₁ /AD ₁ /OB ₁ /AD ₁ /OSB ₃ /AD ₁ /PA ₃ /AD ₁ /IONB ₁ |

- 15 The target (and approximate actual) gauge (in mils) of each layer of the nine-layer film structures is shown below. Layer 9 would preferably form the food or product contact layer in a typical packaging application.

| layer 1 | layer 2 | layer 3 | layer 4 | layer 5 | layer 6 | layer 7 | layer 8 | layer 9 |
|---------|---------|---------|---------|---------|---------|---------|---------|---------|
| 1.35 | 0.34 | 0.50 | 0.25 | 1.00 | 0.25 | 1.50 | 0.34 | 1.35 |

- 20 The films of Example 17, 18, and 19 and Comparative 6 were subjected to food law migration tests to evaluate whether functional

barriers could reduce the concentration of extractables. The films were triggered by ultraviolet light according to the procedure disclosed in U.S. Patent No 5,211,875. The films were converted into 280 cm² pouches and the pouches were filled with the food simulant. The filled pouches were then retorted at 100°C for 30 minutes and stored at 50°C for 10 days. The food simulant was decanted from the pouches and analyzed. Table 9 shows a list of potential extractables. Table 10 shows the concentration of the same extractables, where the films were extracted with 8% ethanol solution. Table 11 shows the concentration of the same extractables, where the films were extracted with water. In both Tables 10 and 11, the concentration of each extractable is in units of nanograms/milliliter. Functional barriers such as polyethylene terephthalate glycol and amorphous nylon can reduce the concentration of certain extractables which could cause regulatory issues.

15

TABLE 9

| ABBREVIATION | DESCRIPTION |
|----------------|------------------------------|
| E ₁ | acetaldehyde |
| E ₂ | acetone |
| E ₃ | formaldehyde |
| E ₄ | benzophenone |
| E ₅ | triphenylphosphine oxide |
| E ₆ | Permanax™ WSP (antioxidant)* |
| E ₇ | dilaurylthiodipropionate |
| E ₈ | cobalt |

* E₃ = 2,2'-methylene bis (4-ethyl-6-(1-methylcyclohexyl)phenol).

TABLE 10

| EX. | E ₁ | E ₂ | E ₃ | E ₄ | E ₅ | E ₆ | E ₇ | E ₈ |
|---------|----------------|----------------|----------------|----------------|----------------|----------------|----------------|----------------|
| COMP. 6 | 195 | <50 | 160 | 109 | <50 | <90 | <62 | <50 |
| 17 | 177 | <50 | 166 | 53 | <50 | <90 | <62 | <50 |

| | | | | | | | | |
|----|-----|-----|-----|-----|-----|-----|-----|-----|
| 18 | 145 | <50 | <50 | 68 | <50 | <90 | <62 | <50 |
| 19 | 69 | <50 | <50 | <50 | <50 | <90 | <62 | <50 |

TABLE 11

| EX. | E ₁ | E ₂ | E ₃ | E ₄ | E ₅ | E ₆ | E ₇ | E ₈ |
|---------|----------------|----------------|----------------|----------------|----------------|----------------|----------------|----------------|
| COMP. 6 | 84 | <50 | 106 | <50 | <50 | <90 | <93 | <50 |
| 17 | 58 | <50 | 92 | <50 | <50 | <90 | <93 | <50 |
| 18 | <50 | <50 | 77 | <50 | <50 | <90 | <93 | <50 |
| 19 | 58 | <50 | 63 | <50 | <50 | <90 | <93 | <50 |

- 5 In Table 12, a four-layer laminate structure in accordance with the invention, and one comparative four-layer laminate structure, are disclosed. The four-layer structures were each made by laminating a coextruded three-layer film, using a conventional adhesive, to a second film (= layer 4).

10

TABLE 12

| EXAMPLE | STRUCTURE |
|---------|--|
| 20 | ION ₃ /OSB ₃ /EV ₂ //AD ₂ //F ₁ |
| COMP. 7 | PE ₁ /OSB ₃ /EV ₂ //AD ₂ //F ₁ |

The target (and approximate actual) gauge (in mils) of each layer of the laminate structures of the invention and the comparative was:

| layer 1 | layer 2 | layer 3 | adhesive | layer 4 |
|---------|---------|---------|-----------|---------|
| 0.30 | 0.50 | 1.20 | (minimal) | 0.50 |

15

Sliced bologna was stored in packages made from the films of Example 20 and Comparative 7. A sensory panel tasted the bologna slices to evaluate whether or not functional barriers can reduce the off-flavor caused by the byproducts of the oxygen-scavenging reaction.

The films were triggered by ultraviolet light according to the procedure disclosed in U.S. Patent No 5,211,875. The films were converted into packages on a Multivac® R7000 packaging machine. Cryovac® T6070B film was used as the bottom web of the packages. Each package contained one slice of bologna. Each package was flushed with a gas mixture consisting of 99% N₂ and 1% O₂. Packages were stored in the dark for 7 days at 40°F.

A sensory panel rated the taste of the bologna slices. The scale ranged from 1 to 6, with 1 indicating extreme off-flavor and 6 indicating no off-flavor. The average scores are summarized in Table 13. A functional barrier, such as an ionomer, can reduce the off-flavor caused by the byproducts of the oxygen-scavenging reaction.

Table 13

| Film | Average Score |
|---------|---------------|
| 20 | 3.80 |
| COMP. 7 | 3.05 |

15

In Table 14, a five-layer laminate structure in accordance with the invention, and one comparative five-layer laminate structure, are disclosed. The five-layer structures were each made by laminating a co-extruded four-layer film, using a conventional adhesive, to a second film (= layer 5).

20

TABLE 14

| EXAMPLE | STRUCTURE |
|---------|--|
| 21 | PE ₁ /EM ₁ /OSB ₁ /EV ₂ //AD ₂ //F ₁ |
| COMP. 8 | PE ₁ /PE ₁ /OSB ₁ /EV ₂ //AD ₂ //F ₁ |

The target (and approximate actual) gauge (in mils) of each layer of the laminate structures of the invention and the comparative was:

25

| | | | | | |
|---------|---------|---------|---------|-----------|---------|
| layer 1 | layer 2 | layer 3 | layer 4 | adhesive | layer 5 |
| 0.15 | 0.15 | 0.50 | 1.20 | (minimal) | 0.50 |

Sliced turkey was stored in packages made from the films of Example 21 and Comparative 8. A sensory panel tasted the turkey slices to evaluate whether or not functional barriers can reduce the off-flavor caused by the byproducts of the oxygen-scavenging reaction.

The films were triggered by ultraviolet light according to the procedure disclosed in U.S. Patent No 5,211,875. The films were converted into packages on a Multivac® R7000 packaging machine. Cryovac® T6070B film was used as the bottom web of the packages. Each package contained one slice of bologna. Each package was flushed with a gas mixture consisting of 99% N₂ and 1% O₂. Packages were stored in the dark for 7 days at 40°F.

A sensory panel rated the taste of the turkey slices. The scale ranged from 1 to 6, with 1 indicating extreme off-flavor and 6 indicating no off-flavor. The average scores are summarized in Table 15. A functional barrier, such as an ethylene-methyl acrylate copolymer, can reduce the off-flavor caused by the byproducts of the oxygen-scavenging reaction.

20

Table 15

| Film | Average Score |
|---------|---------------|
| 21 | 2.75 |
| COMP. 8 | 1.00 |

In Table 16, two five-layer laminate structures in accordance with the invention, and a comparative five-layer laminate structure, are disclosed. The five-layer structures were each made by laminating a coex-

25

extruded four-layer film, using a conventional adhesive, to a second film (= layer 5).

TABLE 16

| EXAMPLE | STRUCTURE |
|---------|---|
| 22 | PE ₁ /PPB ₁ /OSB ₄ /PE ₃ //AD ₂ //F ₁ |
| 23 | PE ₁ /PPB ₂ /OSB ₄ /PE ₃ //AD ₂ //F ₁ |
| COMP. 9 | PE ₁ /PE ₁ /OSB ₄ /EV ₂ //AD ₂ //F ₁ |

5

The target (and approximate actual) gauge (in mils) of each layer of the laminate structures of the invention and the comparative was:

| layer 1 | layer 2 | layer 3 | layer 4 | adhesive | layer 5 |
|---------|---------|---------|---------|-----------|---------|
| 0.15 | 0.15 | 0.50 | 1.00 | (minimal) | 0.50 |

10 Sliced turkey breast was stored in packages made from the films of Examples 22 and 23 and Comparative 9. A sensory panel tasted the turkey slices to evaluate whether or not a functional barrier can reduce the off-flavor caused by the byproducts of the oxygen-scavenging reaction.

15 The films were triggered by ultraviolet light according to the procedure disclosed in U.S. Patent No 5,211,875. The films were converted into packages on a Multivac® R7000 packaging machine. Cryovac® T6070B film was used as the bottom web of the packages. Each package contained one slice of turkey. Each package was flushed with a gas mixture consisting of 99% N₂ and 1% O₂. Packages were stored in the
20 dark for 7 days at 40°F.

A sensory panel rated the taste of the turkey slices. The scale ranged from 1 to 6, with 1 indicating extreme off-flavor and 6 indicating no off-flavor. Table 17 summarizes the percentage of the panelists which did not taste an off-flavor (i.e. a score of 6) in the packaged tur-
25 key slices. In some cases, a functional barrier such as a polypropylene

blend can reduce the off-flavor caused by the byproducts of the oxygen-scavenging reaction.

Table 17

| Film | Percentage of Panelists which did not taste an off-flavor in the packaged turkey |
|---------|--|
| 22 | 17% |
| 23 | 13% |
| COMP. 9 | 15% |

5

Various changes and modifications may be made without departing from the scope of the invention defined below.

The reference to any prior art in this specification is not, and should not be taken as, an acknowledgment or any form of suggestion that that prior art forms part of the common general knowledge in Australia.

Throughout this specification and the claims which follow, unless the context requires otherwise, the word "comprise", and variations such as "comprises" and "comprising", will be understood to imply the inclusion of a stated integer or step or group of integers or steps but not the exclusion of any other integer or step or group of integers or steps.



THE CLAIMS DEFINING THE INVENTION ARE AS FOLLOWS:

1. An article of manufacture, in the form of a film, comprising:
 - (a) a first layer comprising an oxygen barrier;
 - 5 (b) a second layer comprising an oxygen scavenger; and
 - (c) a third layer comprising a polymer selected from the group consisting of polyethylene terephthalate glycol (PETG) and amorphous nylon.

2. The article of claim 1 wherein the oxygen scavenger comprises a material selected
10 from the group consisting of:
 - i) an oxidizable compound and a transition metal catalyst,
 - ii) an ethylenically unsaturated hydrocarbon and a transition metal catalyst,
 - iii) ascorbate,
 - iv) isoascorbate,
 - 15 v) sulfite,
 - vi) ascorbate with a transition metal catalyst, the catalyst comprising a simple metal or salt, or a compound, complex or chelate of the transition metal,
 - vii) a transition metal complex or chelate of a polycarboxylic acid, salicylic acid, or polyamine,
 - 20 viii) a reduced form of a quinone, a photoreducible dye, or a carbonyl compound which has absorbance in the UV spectrum, and
 - ix) tannin.

3. The article of claim 1 or 2, further comprising an abuse resistant layer.
25

4. The article of any one of claims 1 to 3 further comprising a heat sealable layer.

5. The article of any one of the preceding claims wherein the film is cross-linked.

- 30 6. The article of any one of the preceding claims wherein the film is oriented.



7. The article of claim 6 wherein the film is heat shrinkable.

8. The article of any one of the preceding claims wherein at least one of the polymers selected from the group consisting of polyethylene terephthalate glycol (PETG) and amorphous nylon, is blended with a polymer selected from the group consisting of a polymer derived from alkyl acrylate monomer, and a polymer derived from vinyl acetate monomer.

9. The article of any one of the preceding claims wherein the layer formed from at least one of the polymers selected from the group consisting of polyethylene terephthalate glycol (PETG) and amorphous nylon, has an oxygen permeability of greater than 5,000 cc-mil per sq. meter per day per atmosphere at 25°C.

10

10. A package comprising:

- 15 (a) an oxygen sensitive article; and
(b) a container into which the oxygen sensitive article is disposed, the container including:
- i) a layer comprising an oxygen scavenger,
 - ii) a layer comprising a polymer selected from the group consisting of polyethylene terephthalate glycol (PETG) and amorphous nylon, and
 - iii) a layer comprising an oxygen barrier.

20

11. A method of making an article of manufacture having reduced migration of by-products of an oxygen scavenging reaction comprising:

- 25 (a) providing an article comprising
- i) a layer comprising an oxygen scavenger,
 - ii) a layer comprising a polymer selected from the group consisting of polyethylene terephthalate glycol (PETG) and amorphous nylon, and
 - iii) a layer comprising an oxygen barrier; and
- 30 (b) exposing the article to actinic radiation.



12. An article in the form of a polymeric functional barrier coating on an oxygen scavenging lacquer, wherein the polymeric functional barrier coating comprises a polymer selected from the group consisting of polyethylene terephthalate glycol (PETG) and amorphous nylon.

5

13. The article or claim 12 wherein the oxygen scavenger lacquer comprises a material selected from the group consisting of:

- i) an oxidizable compound and a transition metal catalyst,
- ii) an ethylenically unsaturated hydrocarbon and a transition metal catalyst,
- 10 iii) ascorbate,
- iv) isoascorbate,
- v) sulfite,
- vi) ascorbate with a transition metal catalyst, the catalyst comprising a simple metal or salt, or a compound, complex or chelate of the transition metal,
- 15 vii) a transition metal complex or chelate of a polycarboxylic acid, salicylic acid, or polyamine,
- viii) a reduced form of a quinone, a photoreducible dye, or a carbonyl compound which has absorbance in the UV spectrum, and
- ix) tannin.

20

14. An article in the form of a gasket, wherein the gasket comprises an oxygen scavenger, and a polymer selected from the group consisting of polyethylene terephthalate glycol (PETG) and amorphous nylon.

25

15. The article of claim 14 wherein the oxygen scavenger comprises a material selected from the group consisting of:

- i) an oxidizable compound and a transition metal catalyst,
- ii) an ethylenically unsaturated hydrocarbon and a transition metal catalyst,
- iii) ascorbate,
- 30 iv) isoascorbate,
- v) sulfite,

30



- vi) ascorbate with a transition metal catalyst, the catalyst comprising a simple metal or salt, or a compound, complex or chelate of the transition metal,
- vii) a transition metal complex or chelate of a polycarboxylic acid, salicylic acid, or polyamine
- 5 viii) a reduced form of a quinone, a photoreducible dye, or a carbonyl compound which has absorbance in the UV spectrum, and
- ix) tannin.

16. An article according to claim 1 or 12, substantially as herein described with
10 reference to the examples and/or the accompanying figures.

17. A package according to claim 10, substantially as herein described with reference to the examples and/or the accompanying figures.

18

15 18. A method of making an article of manufacture according to claim 11, substantially as herein described with reference to the examples and/or the accompanying figures.

DATED this 31st day of August, 2000

20

20 **CRYOVAC, INC.**

by its Patent Attorneys
DAVIES COLLISON CAVE



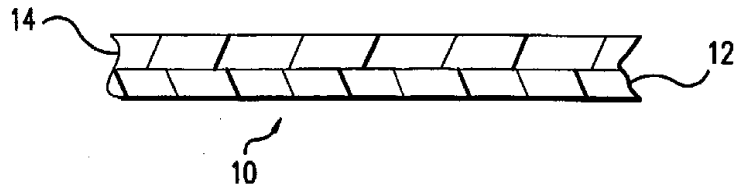

FIG. 1

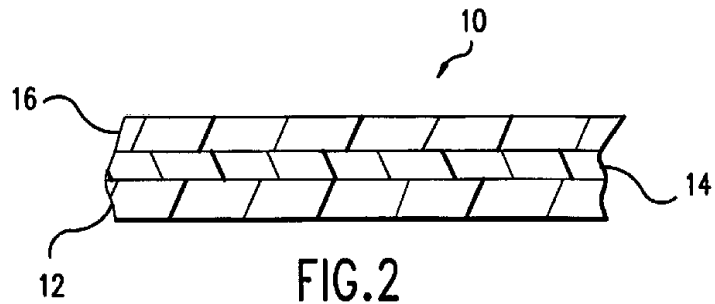

FIG. 2

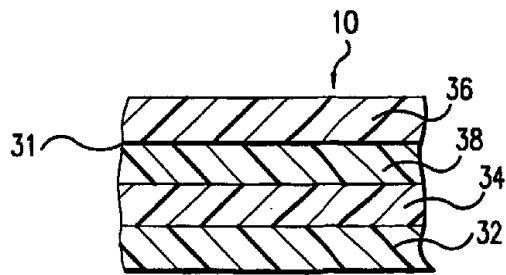

FIG. 3

SUBSTITUTE SHEET (RULE 26)

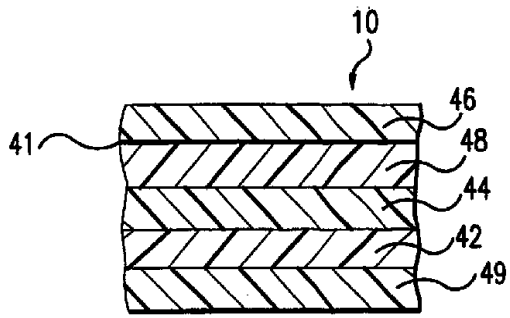

FIG.4

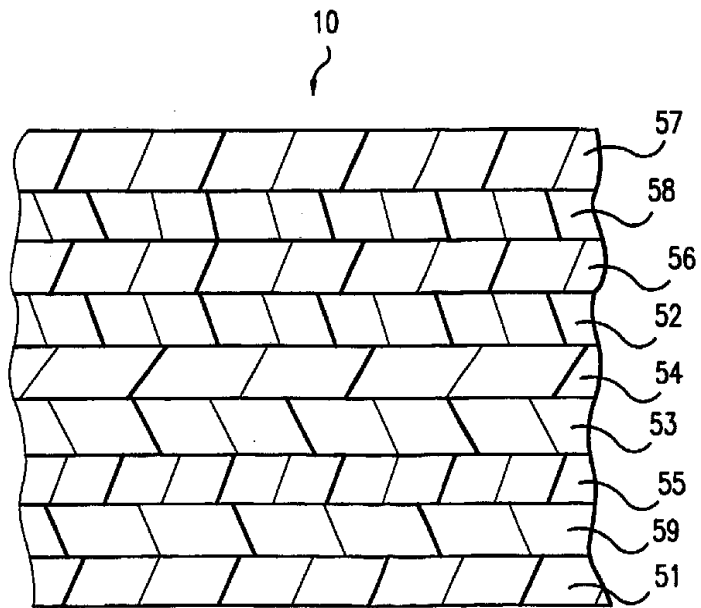

FIG.5

SUBSTITUTE SHEET (RULE 26)

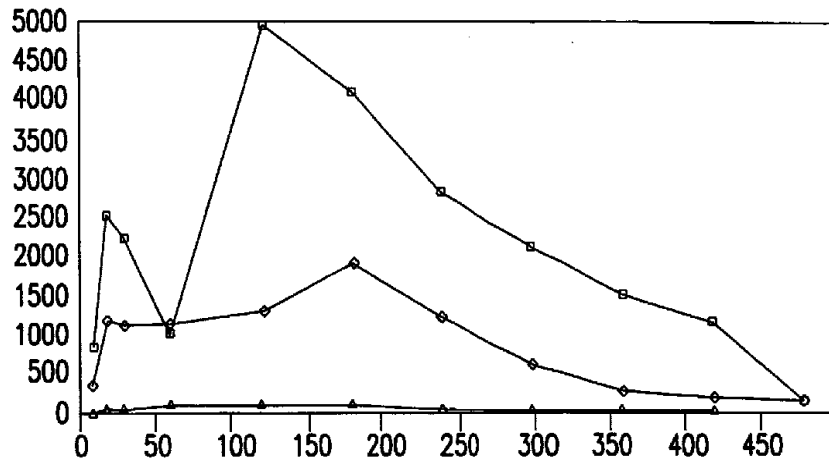

FIG. 6

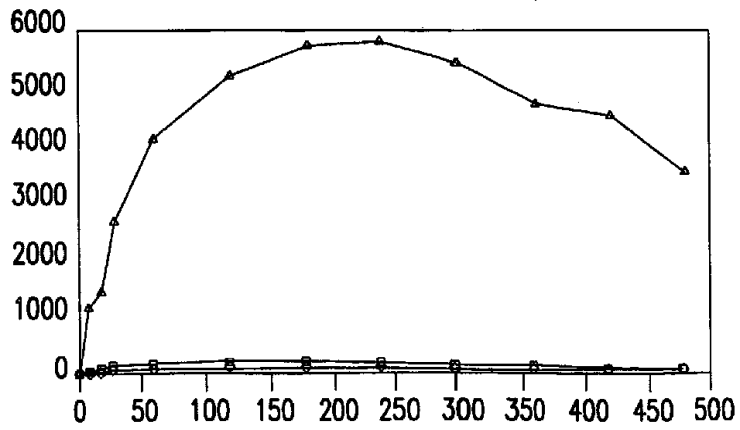

FIG. 7

SUBSTITUTE SHEET (RULE 26)

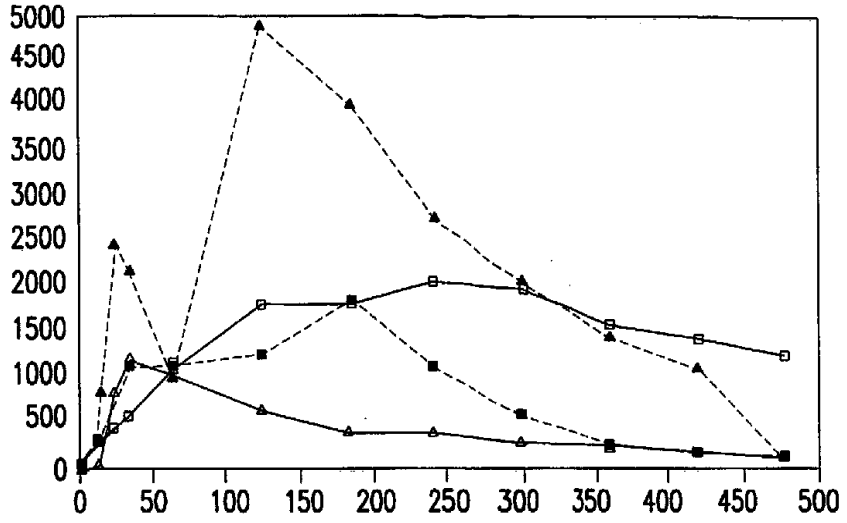

FIG. 8

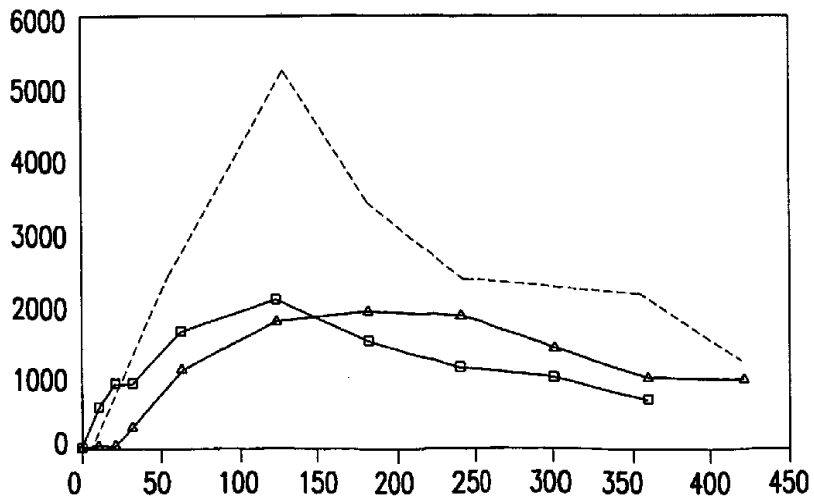

FIG. 9

SUBSTITUTE SHEET (RULE 26)

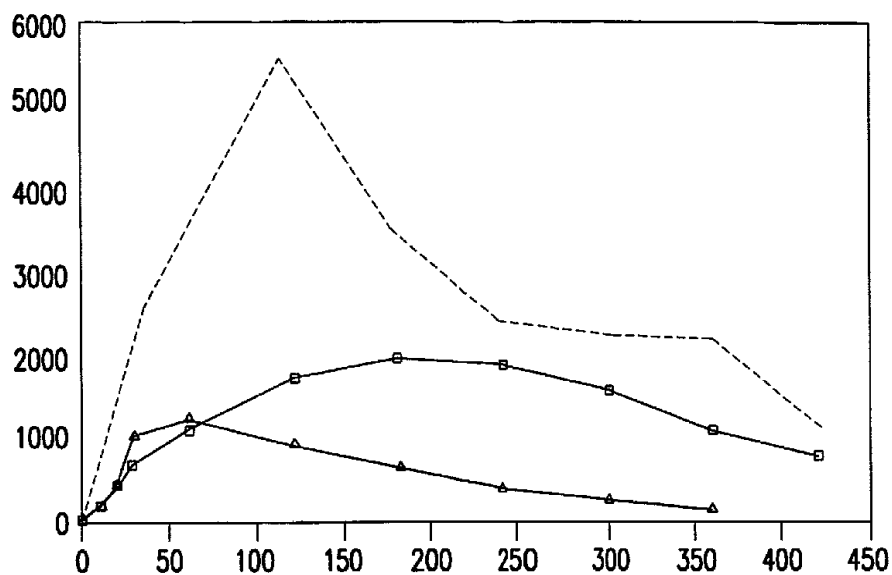

FIG. 10

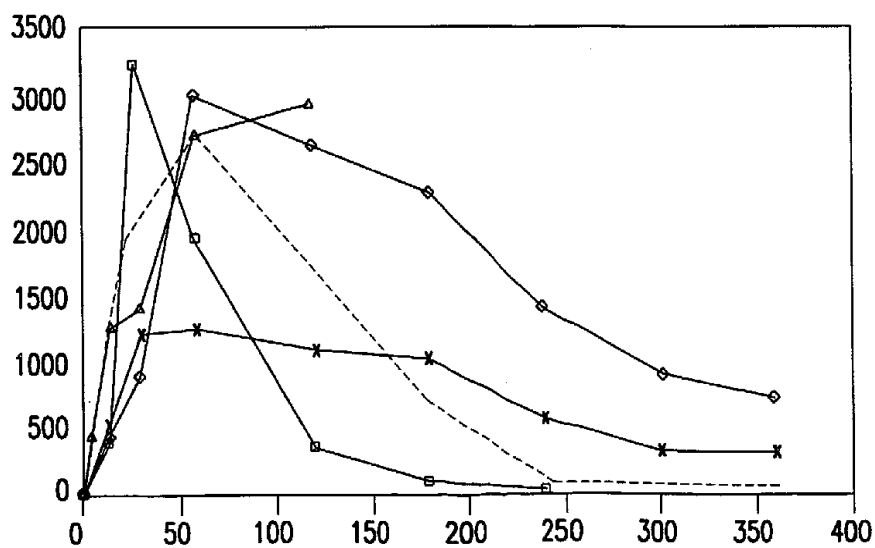

FIG. 11

SUBSTITUTE SHEET (RULE 26)