

(12) UK Patent Application (19) GB (11) 2 300 333 (13) A

(43) Date of A Publication 30.10.1996

(21) Application No 9508657.5

(22) Date of Filing 28.04.1995

(71) Applicant(s)  
**Philips Electronics UK Limited**  
  
(Incorporated in the United Kingdom)

**420-430 London Road, CROYDON, CR9 3QR,  
United Kingdom**

(72) Inventor(s)  
**Nicholas John Stubbs  
Marc Victor Douglas**

(74) Agent and/or Address for Service  
**R J Boxall  
Philips Electronics, Patents and Trade Marks  
Department, Cross Oak Lane, REDHILL, Surrey,  
RH1 5HA, United Kingdom**

(51) INT CL<sup>6</sup>  
**H04B 5/02 1/74 17/00 , H04Q 7/30 7/34**

(52) UK CL (Edition O )  
**H4L LCX LDFC LX2 LX3 L1CT L1H10 L1H2  
U1S S1747**

(56) Documents Cited  
**GB 2280570 A EP 0630125 A2**

(58) Field of Search  
UK CL (Edition O ) **H4L LCAX LCT LCX LDFC LDH LDK  
LDSG LDSX LFM**  
INT CL<sup>6</sup> **E21F 17/18 , H04B 1/74 5/00 5/02 7/005  
17/00 , H04H 3/00 , H04Q 7/30 7/34 7/36**  
**ONLINE : WPI**

(54) **Confined space telecommunications system; transmitter power control**

(57) A telecommunications system for use in confined spaces, such as tunnels, has radio transceiving stations 18 to 26 interconnected by an optical fibre landline 16 to form a series chain, and a base station transceiver 14 for feeding a signal to the line 16. The radio signal from the transceivers 18-26 is propagated via a leaky feeder 12 or via respective antennas (41 to 45, Fig.3). Each transceiving station 18-26 has means for causing the output power of the signal it propagates to be increased when monitoring means (30, Fig.2) in the station senses a deterioration in the performance of at least one neighbouring transceiving station. The monitoring device (30) may sense power failure, signal strength variations, and/or amplifier bias current.

To perform a system health check, a personal computer (50, Fig.4) causes a paging signal to be applied to the leaky feeder 12 via base station transceivers (BS1 to BS10), and the signal propagated by the feeder 12 is picked up by a portable transceiver 48 by means of an antenna (54) or by means of a hard wire connection to the feeder 12.

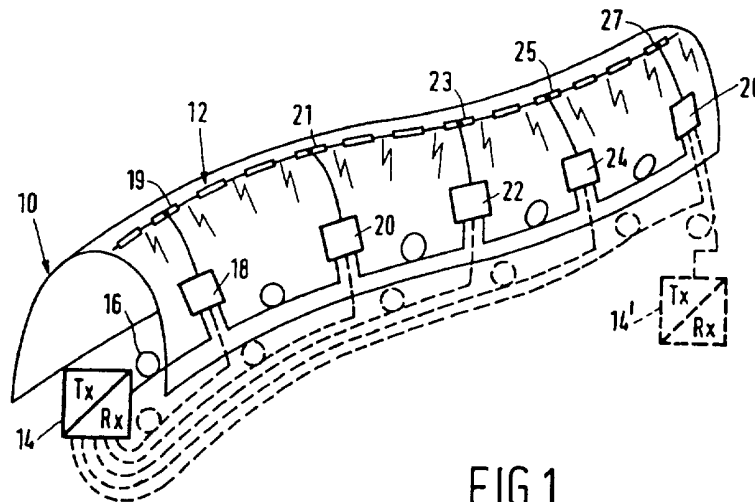

FIG.1

GB 2 300 333 A

1/2

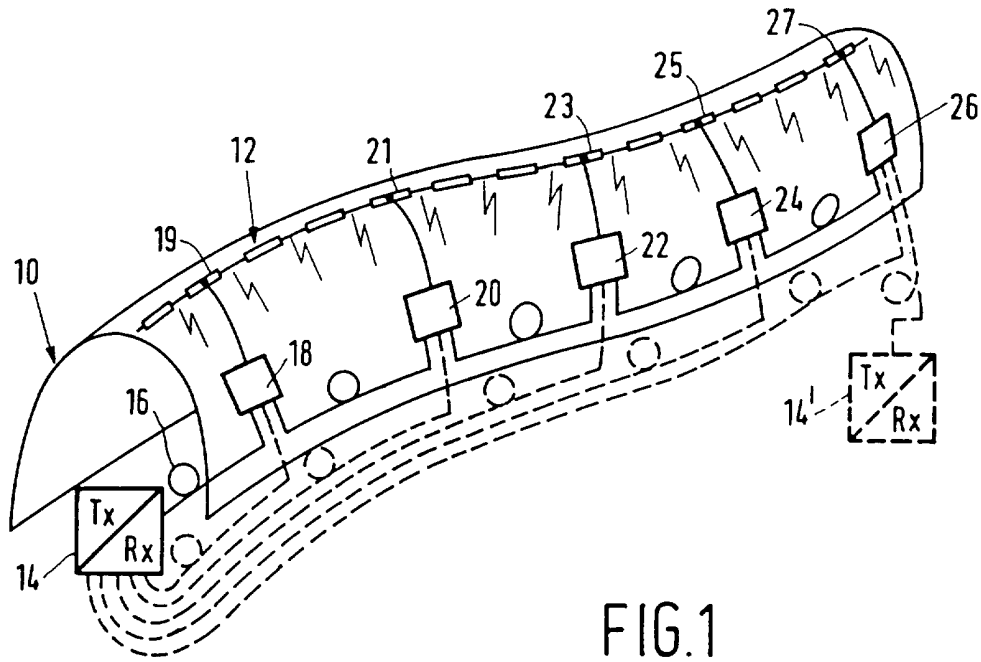

FIG. 1

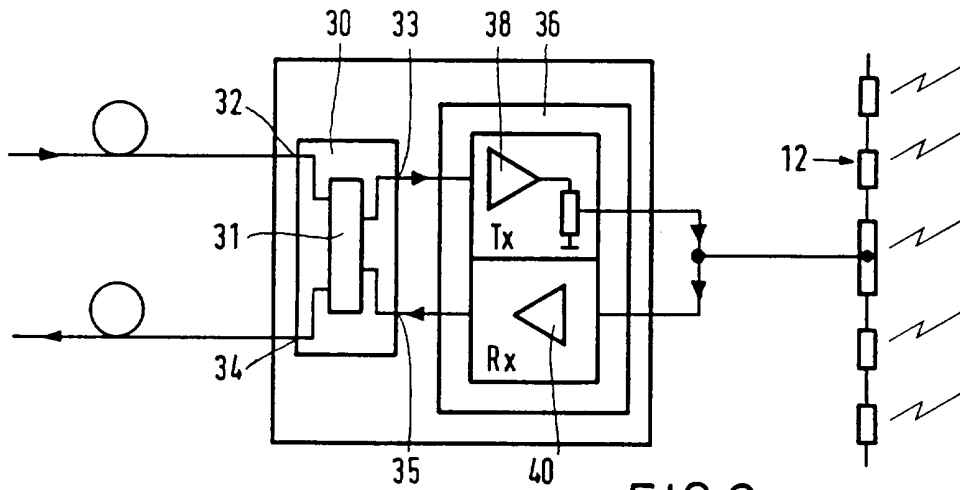

FIG. 2

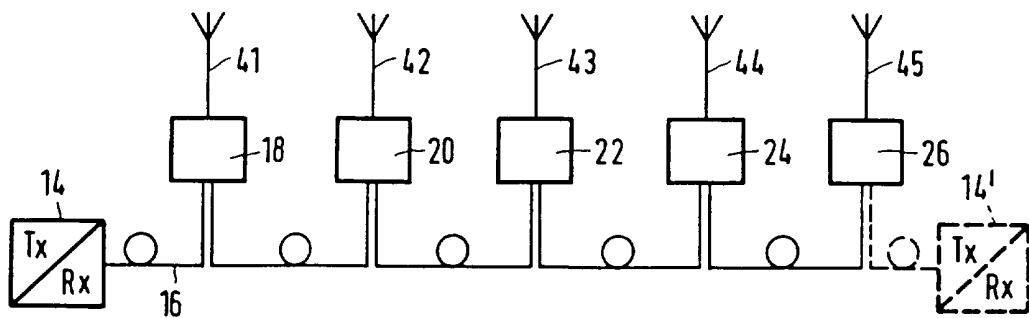

FIG. 3

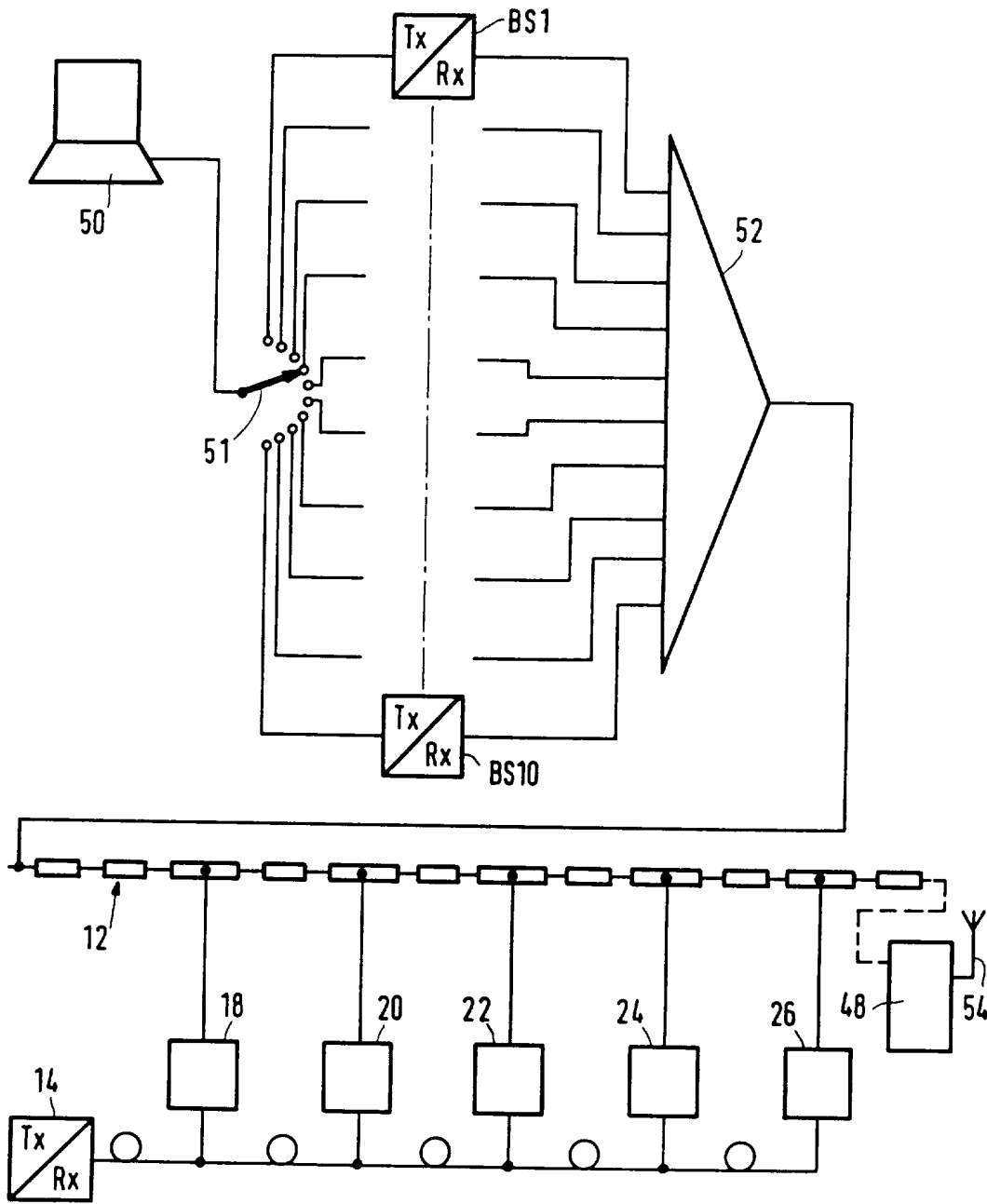

FIG.4

## DESCRIPTION

## CONFINED SPACE TELECOMMUNICATION SYSTEM

5           The present invention relates to a telecommunication system having particular but not exclusive application in confined spaces, especially long tunnels and to a transceiving station for use in such a system.

10           For convenience of description, the present invention will be described with reference to confined spaces but it is to be understood that the principles may be applied to non-confined spaces as well.

15           In long tunnels, communication between users who may be travelling in road, rail or waterborne vehicles is generally by radio via cables which are frequently described as "leaky feeders". With tunnels of a length of up to 0.75km it is sufficient to feed the leaky feeder from one end. However for tunnels having a greater length there is a problem of attenuation and it is customary to provide an optical fibre which is fed with optical wavelength signals from one end and at suitable intervals to tap off the signal, convert it to an electrical signal, amplify it and supply it to suitable spaced points on the leaky feeder.

20           This arrangement is satisfactory when the system is intact physically and the amplifiers are operating properly. However in a crisis situation an amplifier might be physically destroyed thereby causing a radio black spot in the tunnel in an area where perhaps the emergency services may want radio cover. Similarly degeneration of the amplifier or cables will cause deterioration in communication which will eventually lead to the creation of a radio black spot.

30           An object of the present invention is to maintain system integrity and operation in the event of a crisis and/or degeneration.

According to one aspect of the present invention there is provided a telecommunication system comprising a plurality of radio transceiving stations interconnected by a landline and means for feeding a signal to the landline, wherein each transceiving station is coupled to means for propagating a signal, each transceiving station has amplifying means for amplifying said signal, means for monitoring the performance of at least one neighbouring transceiving station and means responsive to detecting a deteriorating change in the performance of the or one of the neighbouring transceiving stations being monitored for causing the output power of the signal it propagates to be increased.

By means of the present invention, the telecommunication system becomes self monitoring insofar that if the performance of a transceiving station degenerates in a way that will cause a radio black spot, the neighbouring station or stations increase their power output to try and eliminate the radio black spot.

In an embodiment of the present invention the means for propagating a signal may comprise an antenna or a tap to a leaky feeder. The landline may comprise an optical fibre in which case the or each transceiving station includes transducing means for converting an optical signal to a corresponding electrical signal which is amplified.

If desired the transceiving stations may be coupled to a central monitoring device. An advantage of using a central monitoring device is that it can provide the system operator with information about which transceiving station or stations is or are malfunctioning or non-operative and in consequence can give a general indication as to not only the location of a possible incident, such as a crash which results in damage to the transceiving station, but also the quality of the radio coverage remaining. Both general indications can be valuable information to the emergency service responding to the incident.

Another advantage of having a central station is to be able to carry out what is termed a "health check" in which the performance of the entire

system is checked. In the case of a system using a leaky feeder as the propagation means, a base station transceiver is, or differently tuned base station transceivers whose outputs/inputs are combined/divided using a combiner which is, coupled to the required point of the leaky feeder.

5 Depending on the implementation of the system the "required point" may be at one end or at a point intermediate the ends in the case of a nominally centre fed system or star system in which leaky feeders radiate in several directions from a common point. At the or each remote end(s) of the leaky feeder(s) a transceiver is located which is capable of selecting and receiving

10 on the or each frequency propagated by the leaky feeder and transmitting a reply giving a status report on the entire system. If desired the transceiver may be coupled to and receive power from the leaky feeder.

According to a second aspect of the present invention there is provided a transceiving station for use in the telecommunication system in

15 accordance with the present invention, the station comprising amplifying means having an input and an output, said output having means for coupling a signal to a signal propagation means, means for monitoring the performance of at least one neighbouring station and means responsive to detecting a deteriorating change in the performance of the or each

20 neighbouring station for causing the output power of the signal propagated by the station to be increased.

The present invention will now be described, by way of example, with reference to the accompanying drawings, wherein:

25 Figure 1 is a sketch diagram showing an embodiment of the invention,  
Figure 2 is a block schematic diagram of a monitoring box,  
Figure 3 is a sketch diagram showing another embodiment of the invention, and

Figure 4 is a sketch diagram of a further embodiment of the invention

30 having means for carrying out a system wide health check.

In the drawings the same reference numerals have been used to

indicate corresponding features.

The embodiment shown in Figure 1 relates to a confined telecommunication system installed in a tunnel 10. A leaky feeder 12 is fitted in the roof of the tunnel. The leaky feeder 12 may comprise a coaxial cable with the earth screening bared to permit rf radiation carried by a central conductor to radiate through the exposed areas. A base station transceiver 14 is coupled to an optical fibre 16 which extends along the tunnel 10. Radio transceiving stations 18 to 26 are provided at intervals on the wall of the tunnel and are interconnected by the optical fibre 16 to form a series chain. The stations 18 to 26 include transducing means for converting optical signals into electrical signals which are amplified and supplied to respective taps 19 to 27 provided at intervals along the leaky feeder 12. The transceiving stations 18 to 26 each comprise a signal monitoring device 30 having ports 32, 34 (Figure 2) for an input optical signal and an output optical signal, respectively, ports 33, 35 for electrical output and input signals, respectively, and transducing means 31 for converting optical signals into electrical signals and vice versa. A transceiver 36 includes respective transmit and receive amplifiers 38, 40. The amplifier 38 amplifies a signal on the port 33 and supplies it to an associated tap of the leaky feeder. The amplifier 40 amplifies signals from the leaky feeder 12, which signals are supplied to the port 35. These signals after being transduced into optical signals are supplied to the port 34 to be relayed to the base station transceiver 14 by way of the optical fibre 16.

Each transceiving station not only transduces optical signals into corresponding electrical signals and vice versa but also monitors the quality of the signal(s) produced by its immediately neighbouring transceiving station, upstream and downstream, and in response to a signal deteriorating due to say degeneration of an amplifier in the neighbouring station or the complete loss of a neighbouring station due to its being ripped off the wall due to a collision, it boosts its output power in order to increase the range

of signals propagated by its associated length of leaky feeder. Similarly the transmitter amplifier in the transceiving station located at the other side of the fault area also boosts its power output. Thus the risk of a radio coverage black spot is reduced if not eliminated. In order to illustrate what happens, assume that the station 22 (Figure 1) is not functioning properly, this is sensed by the monitoring devices 30 in the stations 20, 24 who boost their power amplifier outputs to increase their coverage areas.

The monitoring devices 30 may sense power failure, signal strength variations and/or amplifier bias current.

The power amplifiers 38 in the respective stations may be set up to provide a substantially constant power output in normal operation, some of which power is attenuated or dumped. However the attenuation or dumping of the power is curtailed when operating in a power boost mode to compensate for the reduction or loss of power by a neighbouring station. The curtailment of the output power dumping may be graduated to obtain a more precise control.

Although the self monitoring operation could in theory extend beyond immediate neighbouring transceiving station(s), a difficulty may arise in that the maximum power output of the power amplifiers is defined and cannot be exceeded. Therefore if a station cannot contribute to overcoming the effects of losing a distant station then there is less reason to monitor its state.

Figure 3 shows another embodiment in which the signal propagation means comprise antennas 41 to 45. The self monitoring aspect is the same as described with reference to Figures 1 and 2 and accordingly in the interests of brevity it will not be repeated.

Figure 4 illustrates the embodiment of the invention having means for carrying out a system health check. The provision for a health check facility is known per se. The principle of the health check is to transmit say a 5-tone paging signal by way of the leaky feeder 12 and for a portable radio transceiver unit 48 at the opposite end of the leaky feeder to determine the reception quality of the paging signal and relay the results back via the leaky



feeder. The signal generating end of the health check facility comprises a personal computer 50 coupled by a single pole multiway switch 51 to say ten base station transceivers BS1 to BS10, each operating at a different frequency. The transmitter/receiver of each base station is connected to a signal combiner/divider 52 coupled to the leaky feeder 12.

The portable transceiver unit 48, which is able to scan the base station frequencies, may pick up the signals propagated by the leaky feeder 12 by means of an antenna 54. However the unit 48 may be hard wired to the leaky feeder 12 in which case it can be powered by current applied to the leaky feeder.

The self monitoring aspect of this embodiment is as described previously with reference to Figures 1 and 2.

Possible variants of the illustrated telecommunication system include (a) providing a second base station transceiver 14' (Figure 1 or 3) connected to the other end of the optical fibre 16, this has the advantage that communication can be maintained even if the optical fibre 16 is severed intermediate its ends, (b) providing an independent optical fibre connection to each of the transceiving stations, shown in broken lines in Figure 1, in addition to the series connection provided by the optical fibre 16, this also provides a higher level of system integrity, (c) centre feeding arrangements (not shown) can be implemented in systems having a star configuration, and (d) modifying the "health check" arrangements from that shown in Figure 4 so that the personal computer 50 and the base station transceivers BS1 to BS10 are coupled to the leaky feeder at the required point which may be intermediate the ends of the leaky feeder or at a node of a star arrangement of leaky feeders, with these alternative arrangements a portable transceiver 48 is provided at or is operatively coupled to each end of the leaky feeder.

From reading the present disclosure, other modifications will be apparent to persons skilled in the art. Such modifications may involve other features which are already known in the design, manufacture and use of telecommunication systems and component parts thereof and which may be

used instead of or in addition to features already described herein. Although claims have been formulated in this application to particular combinations of features, it should be understood that the scope of the disclosure of the present application also includes any novel feature or any novel combination of features disclosed herein either explicitly or implicitly or any generalisation thereof, whether or not it relates to the same invention as presently claimed in any claim and whether or not it mitigates any or all of the same technical problems as does the present invention. The applicants hereby give notice that new claims may be formulated to such features and/or combinations of such features during the prosecution of the present application or of any further application derived therefrom.

## CLAIMS

1. A telecommunication system comprising a plurality of radio transceiving stations interconnected by a landline and means for feeding a signal to the landline, wherein each transceiving station is coupled to means for propagating a signal, each transceiving station has amplifying means for amplifying said signal, means for monitoring the performance of at least one neighbouring transceiving station and means responsive to detecting a deteriorating change in the performance of the or one of the neighbouring transceiving stations being monitored for causing the output power of the signal it propagates to be increased.

2. A system as claimed in claim 1, characterised in that the means for propagating a signal comprises a leaky feeder.

3. A system as claimed in claim 1 or 2, characterised in that the means for propagating a signal comprises an antenna.

4. A system as claimed in claim 1, 2 or 3, characterised in that the landline comprises an optical fibre and in that the transceiving station comprises means for converting an optical signal into a corresponding electrical signal.

5. A system as claimed in claim 2, characterised by system monitoring means comprising signal generating means coupled to the leaky feeder and a transceiver operatively coupled to at least one end of the leaky feeder.

6. A system as claimed in any one of claims 1 to 5, characterised in that the amplifying means in each transceiving station further comprises power attenuating means for attenuating the output power of the amplifying

means in normal operation of the transceiving station.

5 7. A transceiving station for use in a system as claimed in claim 1, comprising amplifying means having an input and an output, said output having means for coupling a signal to a signal propagation means, means for monitoring the performance of at least one neighbouring station and means responsive to detecting a deteriorating change in the performance of the or each neighbouring station for causing the output power of the signal propagated by the station to be increased.

10

8. A transceiving station as claimed in claim 7, characterised in that the amplifying means further comprises power attenuating means for attenuating the output power of the amplifying means in normal operation of the transceiving station.

15

9. A telecommunication system constructed and arranged to operate substantially as hereinbefore described with reference to and as shown in the accompanying drawings.

20

10. A transceiving station constructed and arranged to operate substantially as hereinbefore described with reference to and as shown in the accompanying drawings.



Application No: GB 9508657.5  
Claims searched: 1 to 10

Examiner: M J Billing  
Date of search: 8 May 1996

**Patents Act 1977**  
**Search Report under Section 17**

**Databases searched:**

UK Patent Office collections, including GB, EP, WO & US patent specifications, in:  
UK CI (Ed.O): H4L LCAX, LCT, LCX, LDFC, LDH, LDK, LDSG, LDSX, LFM.  
Int CI (Ed.6): E21F 17/18; H04B 1/74, 5/00, 5/02, 7/005, 17/00; H04H 3/00; H04Q  
7/30, 7/34, 7/36.  
Other: ONLINE : WPI.

**Documents considered to be relevant:**

Category	Identity of document and relevant passage	Relevant to claims
X	GB2280570A (MOTOROLA) - Abstract, page 6 lines 25-27	1,3,6,7,8 at least
A	EP0630125A2 (MOTOROLA) - column 6 lines 19-46	1,7 at least

X	Document indicating lack of novelty or inventive step	A	Document indicating technological background and/or state of the art.
Y	Document indicating lack of inventive step if combined with one or more other documents of same category.	P	Document published on or after the declared priority date but before the filing date of this invention.
&	Member of the same patent family	E	Patent document published on or after, but with priority date earlier than, the filing date of this application.