

(72) HIRSCH, LUCIAN, DE

(72) SCHMID-BAUER, ALFRED, DE

(71) SIEMENS AKTIENGESELLSCHAFT, DE

(51) Int.Cl.⁶ H04M 17/00

(30) 1998/05/11 (198 21 032.9) DE

(54) **PROCEDE ET SYSTEME DE COMMUNICATION POUR
TRAITER DES INFORMATIONS D'ETAT PAR
L'INTERMEDIAIRE D'UN RESEAU DE GESTION
PRESENTANT PLUSIEURS NIVEAUX DE GESTION**

(54) **METHOD AND COMMUNICATION SYSTEM FOR
PROCESSING STATE INFORMATION IN A MANAGEMENT
NETWORK HAVING DIFFERENT MANAGEMENT LEVELS**

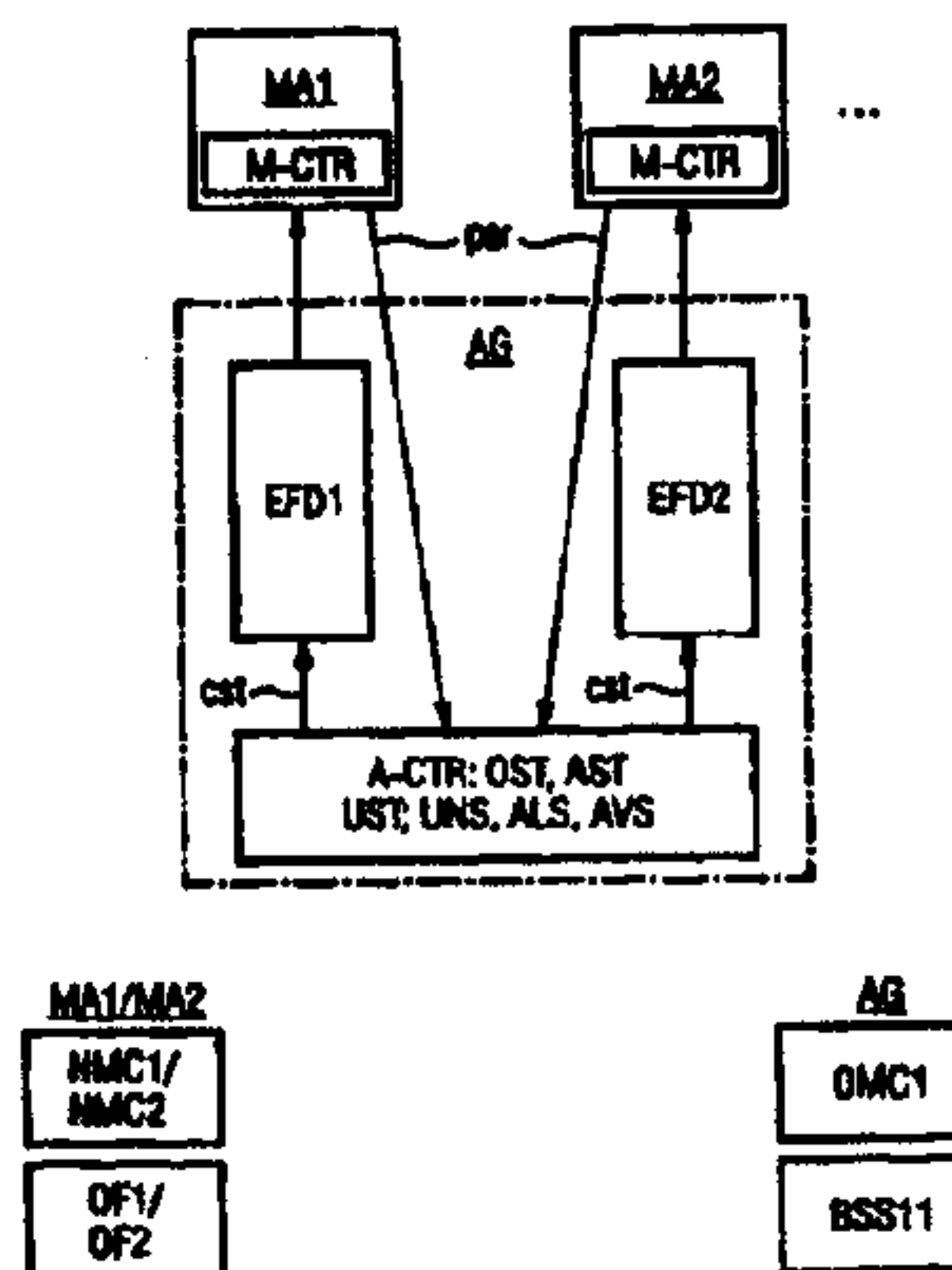
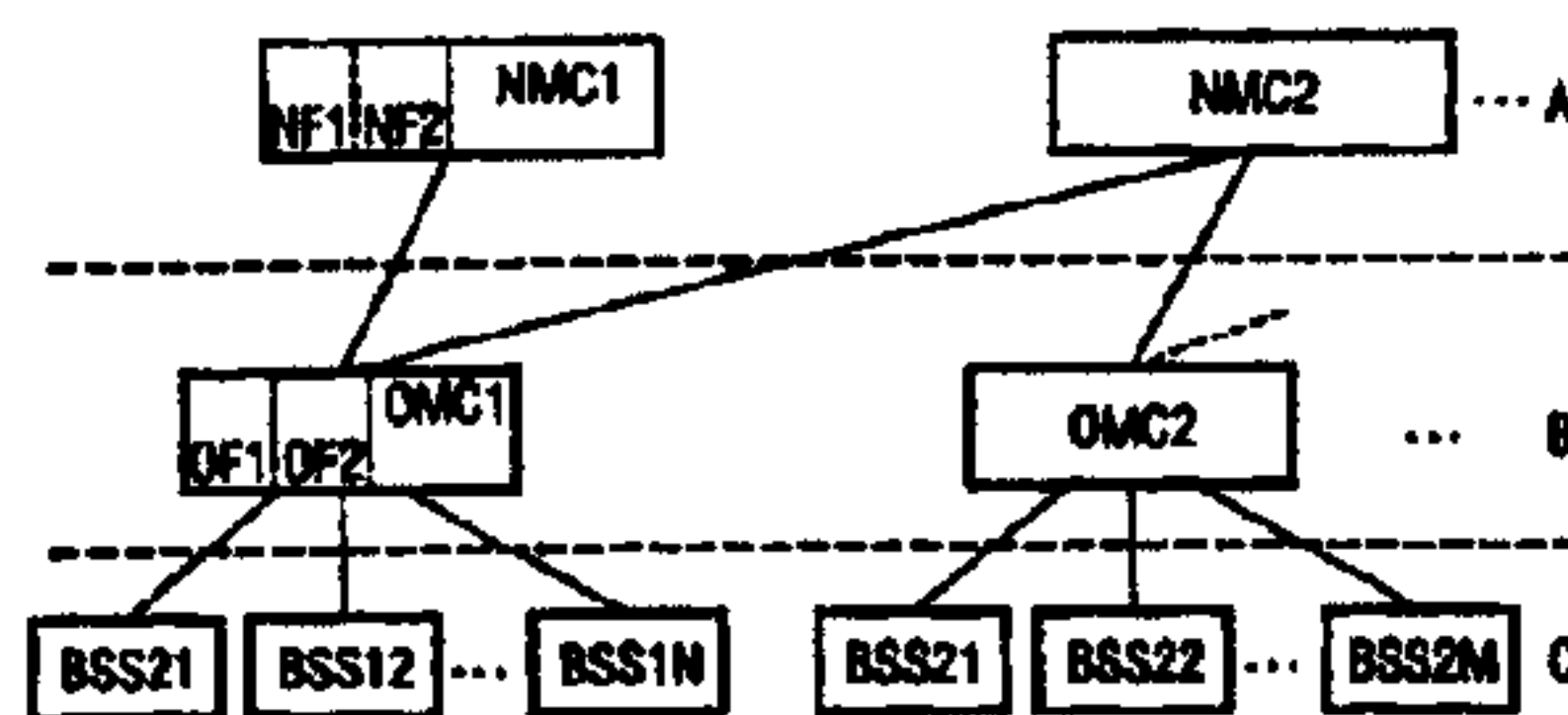

(57) Selon l'invention, les informations d'état sont transmises entre un agent (AG) d'un niveau de gestion (B, C) et au moins un gestionnaire (MA1, MA2) d'un niveau de gestion (A, B) immédiatement supérieur. Un message d'exigence (staAS) pour l'exécution de l'alignement d'informations est envoyé par le gestionnaire (MA1, MA2) à l'agent (AG). Ce dernier

(57) According to the invention, state information is transmitted between an agent (AG) of a management level (B, C) and at least one manager (MA1, MA2) of a next higher management level (A, B). A request message (staAS) is sent by the manager (MA1, MA2) to the agent (AG) for executing information matching. State information regarding deviations from a normal state are

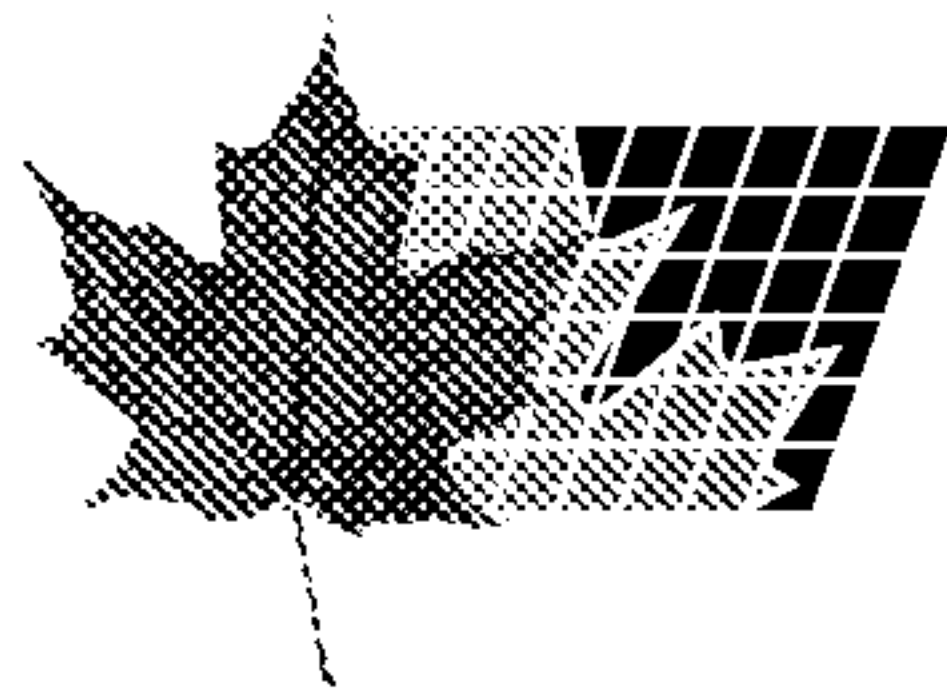

(21) (A1) **2,331,899**

(86) 1999/05/03

(87) 1999/11/18

contrôle si les informations d'état s'écartent de l'état normal et envoie au gestionnaire (MA1, MA2) des modifications des informations d'état dans un ou plusieurs messages successifs (staCN). L'alignement d'informations s'effectue uniquement en présence d'informations d'état modifiées, de sorte que les écarts par rapport à l'état normal sont communiqués au gestionnaire. Par conséquent, le gestionnaire ne reçoit pas automatiquement toutes les informations d'état, qu'elles aient été modifiées ou non. Il en résulte un flux d'informations réduit entre l'agent et le gestionnaire, ce qui constitue un gain considérable du côté du gestionnaire notamment lorsqu'une pluralité d'objets sont gérés.

checked by the agent (AG) and changes in state information are sent to the manager (MA1, MA2) in one or several successive messages (staCN). Information matching is conducted only when changes in state information exist so that deviations from normal state are informed to the manager. Consequently, all state information regardless of whether said information has changed or not is not automatically transmitted to the manager. This results in reduced information flow between the agent and the manager and represents a considerable gain for the manager especially in the case of a plurality of managed objects.



PCT
WELTORGANISATION FÜR GEISTIGES EIGENTUM
Internationales Büro
INTERNATIONALE ANMELDUNG VERÖFFENTLICHT NACH DEM VERTRAG ÜBER DIE
INTERNATIONALE ZUSAMMENARBEIT AUF DEM GEBIET DES PATENTWESENS (PCT)

<p>(51) Internationale Patentklassifikation ⁶ : H04M 17/00</p>	A2	<p>(11) Internationale Veröffentlichungsnummer: WO 99/59326</p> <p>(43) Internationales Veröffentlichungsdatum: 18. November 1999 (18.11.99)</p>
<p>(21) Internationales Aktenzeichen: PCT/DE99/01309</p> <p>(22) Internationales Anmeldedatum: 3. Mai 1999 (03.05.99)</p> <p>(30) Prioritätsdaten: 198 21 032.9 11. Mai 1998 (11.05.98) DE</p> <p>(71) Anmelder (für alle Bestimmungsstaaten ausser US): SIEMENS AKTIENGESELLSCHAFT [DE/DE]; Wittelsbacherplatz 2, D-80333 München (DE).</p> <p>(72) Erfinder; und (75) Erfinder/Anmelder (nur für US): HIRSCH, Lucian [DE/DE]; Drachenseestrasse 3, D-81373 München (DE). SCHMID-BAUER, Alfred [DE/DE]; Hofoldingenstrasse 3, D-81671 München (DE).</p> <p>(74) Gemeinsamer Vertreter: SIEMENS AKTIENGESELLSCHAFT; Postfach 22 16 34, D-80506 München (DE).</p>	<p>(81) Bestimmungsstaaten: CA, CN, JP, US, europäisches Patent (AT, BE, CH, CY, DE, DK, ES, FI, FR, GB, GR, IE, IT, LU, MC, NL, PT, SE).</p> <p>Veröffentlicht <i>Ohne internationalen Recherchenbericht und erneut zu veröffentlichen nach Erhalt des Berichts.</i></p>	

(54) **Title:** METHOD AND COMMUNICATION SYSTEM FOR PROCESSING STATE INFORMATION IN A MANAGEMENT NETWORK HAVING DIFFERENT MANAGEMENT LEVELS

(54) **Bezeichnung:** VERFAHREN UND KOMMUNIKATIONSSYSTEM ZUR BEHANDLUNG VON ZUSTANDSINFORMATIONEN DURCH EIN MEHRERE MANAGEMENTEBENEN AUFWEISENDES MANAGEMENTNETZ

(57) **Abstract**

According to the invention, state information is transmitted between an agent (AG) of a management level (B, C) and at least one manager (MA1, MA2) of a next higher management level (A, B). A request message (staAS) is sent by the manager (MA1, MA2) to the agent (AG) for executing information matching. State information regarding deviations from a normal state are checked by the agent (AG) and changes in state information are sent to the manager (MA1, MA2) in one or several successive messages (staCN). Information matching is conducted only when changes in state information exist so that deviations from normal state are informed to the manager. Consequently, all state information regardless of whether said information has changed or not is not automatically transmitted to the manager. This results in reduced information flow between the agent and the manager and represents a considerable gain for the manager especially in the case of a plurality of managed objects.

(57) **Zusammenfassung**

Die Erfindung geht davon aus, daß die Zustandsinformationen zwischen einem Agent (AG) einer Managementebene (B, C) und zumindest einem Manager (MA1, MA2) einer nächsthöheren Managementebene (A, B) übertragen werden. Gemäß dem Gegenstand der Erfindung wird von dem Manager (MA1, MA2) eine Anforderungsnachricht (staAS) zur Durchführung des Informationsabgleichs an den Agent (AG) gesendet. Von dem Agent (AG) werden die Zustandsinformationen hinsichtlich Abweichungen von einem Normalzustand überprüft und Änderungen der Zustandsinformationen in einer oder mehreren aufeinanderfolgenden Nachrichten (staCN) an den Manager (MA1, MA2) gesendet. Durch den Erfindungsgegenstand erfolgt der Informationsabgleich nur, wenn geänderte Zustandsinformationen vorliegen, so daß die Abweichungen vom Normalzustand dem Manager mitgeteilt werden. Folglich erhält der Manager nicht automatisch alle Zustandsinformationen übermittelt, unabhängig davon, ob sie sich geändert haben oder nicht. Daraus ergibt sich ein reduzierter Informationsfluß zwischen Agent und Manager, was insbesondere bei einer Vielzahl von gemanagten Objekten seitens des Managers einen erheblichen Gewinn darstellt.

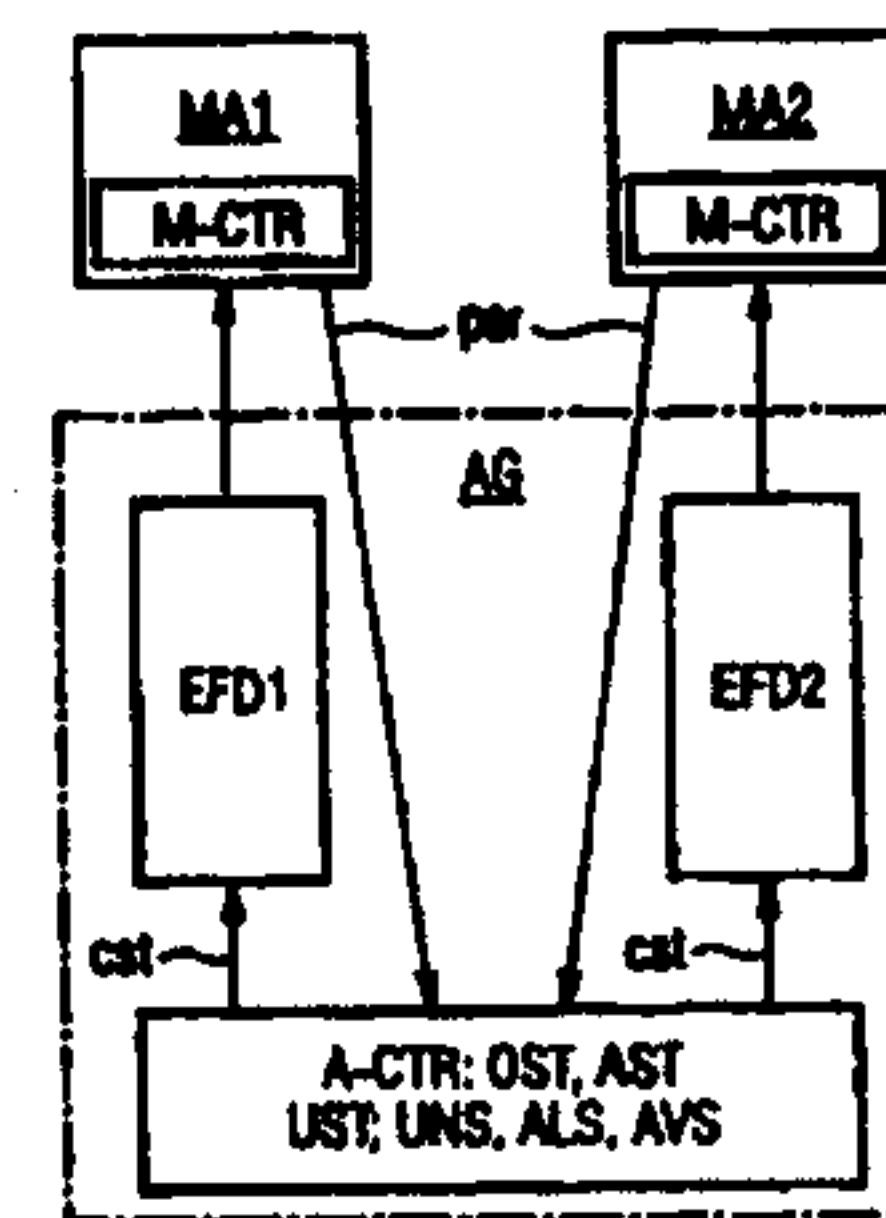
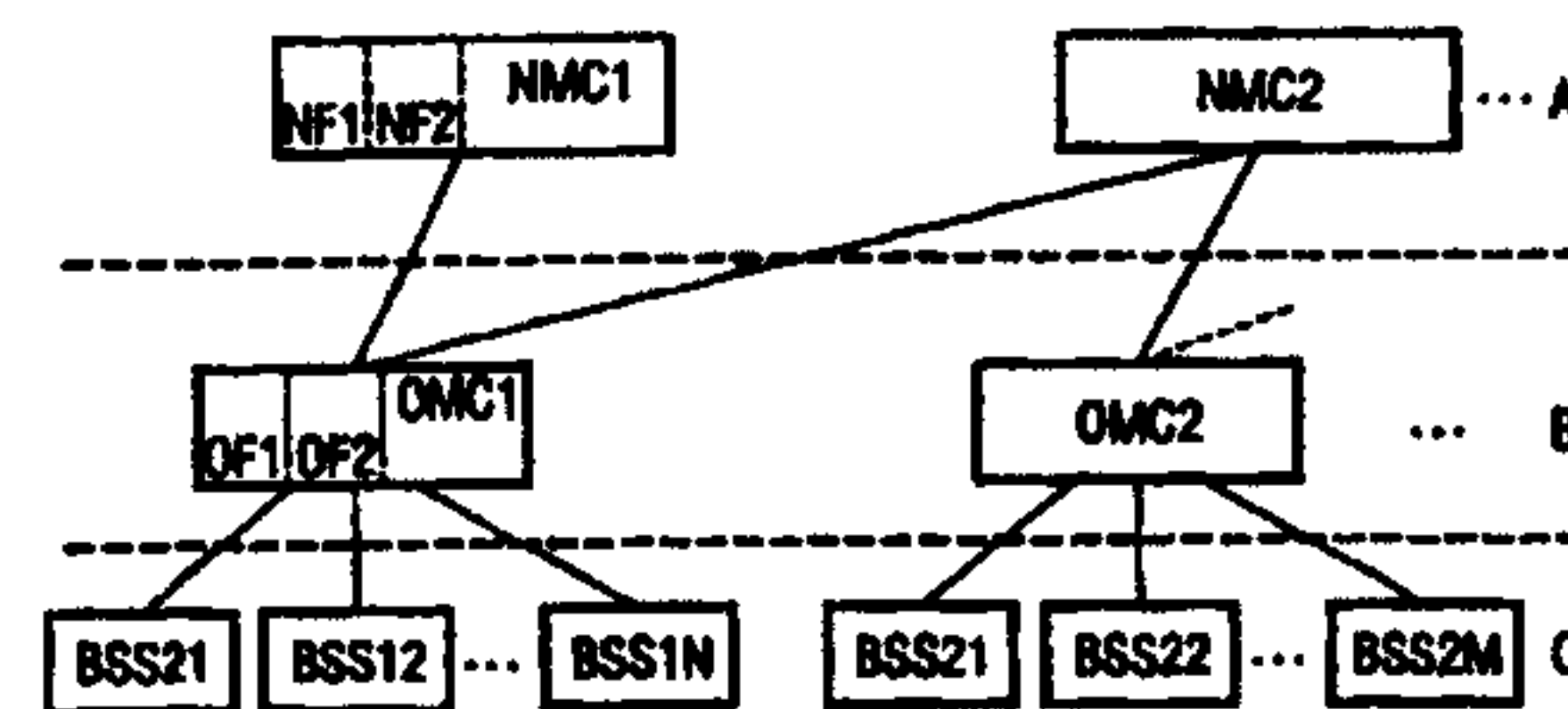

GR 98 P 1698

Description

Method and communications system for processing state information in a management network having a number of
5 management levels

The invention relates to a method and a corresponding communications system for processing state information in a management network having a
10 number of management levels, the state information being transmitted between an agent of one management level and at least one manager of a next higher management level for a state realignment.

The principles of a management network, which
15 are also called TMN (Telecommunications Management Network) principles, define a number of management levels for the management of a communications system - for example a mobile communications system, each level having a dual function. In the managing system, each
20 level, apart from the lowest one, has a manager function for the level below. In the managed system, each level, apart from the topmost one, has an agent function for the next higher level.

The management of state information (state
25 management) represents one of a number of TMN function areas which characterizes the state of a managed object. A managed object is a logical abstraction of a resource in the communications system. A distinction is made here between hardware-related managed objects
30 which describe a manufacturer-related implementation of a function, and function-related managed objects which are in each case the abstraction of a manufacturer-independent functionality. In an object-oriented environment - such as between manager and agent in a
35 mobile communications system - each agent functionality is provided by a particular object - as instance of an object class - which is

known both to the agent and to the manager. The management state of an object can be described by means of state information according to the ITU-T X.731 standard. In this arrangement, each change of the state
5 of a managed object is transmitted by the agent to the manager in corresponding messages.

If the connection between the two management levels, that is between agent and manager, is no longer guaranteed for a particular period, the agent must
10 temporarily store the changes in the state which have occurred during this interval, in order to ensure that, after the communication capability has been restored, the manager is provided as rapidly as possible with an overview of the current state of the object. For this
15 purpose, a state realignment is performed between agent and manager - for example during the setting up of a new connection after a connection termination or after an initialization of the agent or of the manager. In principle, the manager plays the active role by
20 triggering the state realignment and requesting and receiving the state information for each existing object from the agent. Requesting and transmission is always done for all agent objects, i.e. independently of the content of the respective state information at
25 the time of the request by the manager. In the case of a relatively large number of managed objects, the signaling load is considerable and leads to the alignment procedure taking an undesirably long time.

It is the object of the invention to specify a
30 method and communications system for processing state information in a management network having a number of management levels for improved state realignment.

According to the invention, this object is achieved by the features of patent claim 1 with respect
35 to the method and by the features of patent claim 17 with respect to the communications system. Further developments of the invention can be

GR 98 P 1698

- 3 -

found in the subclaims.

The invention is based on the fact that state information is transmitted between an agent of one management level and at least one manager of a next
5 higher management level for a state realignment. According to the subject matter of the invention, the manager sends a request message for performance of the state realignment to the agent. The agent checks the state information with respect to deviations from a
10 normal state and sends changes in the state information to the manager in one or a number of successive messages.

As a result of the subject matter of the invention, the state realignment is only performed when
15 changed state information is present so that the manager is informed by the agent on request of deviations from the normal state. In consequence, not all state information is automatically transmitted, irrespective of whether it has changed or not. This
20 results in a reduced information flow between agent and manager which represents a considerable gain for the manager if there is a large number of managed objects. The manager, however, is only interested in the changes in the state information which are necessary for the
25 state realignment, it is consequently only provided with these deviations in accordance with the subject matter of the invention. In consequence, the transmission of state information for which the agent has found no deviation from the normal state can be
30 omitted.

According to a further development of the invention, state attributes and/or status attributes are used as state information. The normal state is preferably defined by means of predeterminable values
35 for the state attributes and/or status attributes. Due to the above attributes, detailed information on the changed state of each

GR 98 P 1698

- 4 -

existing object can be called up by the manager and provided by the agent.

State attributes for characterizing the operational readiness, the manageability and the use of a resource supported by the agent in the communications system are preferably used as state information. Furthermore, status attributes which specify, for a resource supported by the agent in the communication system, whether it is in an unknown state, in an alarm state or in a state of availability, are preferably used as state information. Due to the transmission of only the changed attributes, the manager only receives the detailed information required as a minimum in order to produce the state realignment between manager and agent.

It has been found to be advantageous if the manager, in the request message, also sends a correlation information item for correlating the respective request with the messages containing the changed state information received from the agent. As a result, a number of requests for state realignment can run simultaneously or serially. The parallel solution has the advantages of an even better utilization of the transmission resources at the interface of the agent/manager relation and a faster provision of the changed state information for the next higher management level. Due to the correlation by means of the unambiguous correlation information issued by the manager, there is the additional possibility of allocating the incoming responses of the agent, containing the changed state information, to the correct request even if the order is not maintained. Successively initiated requests can mutually overtake each other, for example when a packet data network is traversed between agent and manager. The agent can process a number of requests in parallel and immediately thereafter send back the state information

GR 98 P 1698

- 5 -

to the manager or managers for state realignment without regard to the order of the started requests.

A further advantageous development of the invention provides that a correlation information item
5 for a correlation of the subsequently transmitted messages containing the changed state information with the state realignment started in each case is also sent by the agent in a message to start the state realignment. The unambiguous correlation information
10 issued by the agent guarantees that the changed state information items of various state realignments running simultaneously or in series reach the manager which in each case is processing the received state information further, independently of the time when they are sent
15 out by the agent.

According to a particularly advantageous further development of the invention, the manager controls the state realignment in dependence on at least one parameter sent to the agent. The advantage of a state
20 realignment which can be parameterized compared with the base functionality lies in that only certain state information is transmitted on the basis of the parameter transmitted. This provides the manager with a selection function for a subset of all state information. In
25 particular, the possibility of a controlling influence on the realignment by simple means and by using standardized messages increases the flexibility of the manager and additionally reduces the message and information flow. Due to the parameterizable alignment
30 functionality for processing the state information it is possible, for example, to achieve a selection of resources and/or an active control of the order of the requested information. In particular, the combination of the base functionality - transmission of only the
35 changes of the state on the basis of deviations compared with the normal state - with the parameterizable alignment functionality leads to a particularly effective method and communications system

GR 98 P 1698

- 6 -

which results in optimum utilization of transmission resources at the interface of the agent/manager relation and the fastest possible provision by the agent of only the state information requested by the manager for the next higher management level.

According to a further development of the invention, the manager sends a parameter by means of which the state realignment is automatically initiated by the agent. Thus, the state realignment can be controlled by the manager in such a manner that it is triggered automatically by the agent at certain times.

According to further advantageous developments of the invention, the parameterization can take place with one or more of the following parameter values, in each case set by the manager. Thus, a parameter is provided by the manager with parameter values which specify a starting time for the automatic state realignment and/or an end time for the automatic state realignment. Other parameter values define

- a time interval for a repetition of the automatic state realignment,
- selected resources for which changed state information is to be transmitted by the agent,
- the termination of a running state realignment.

In the text which follows, the invention will be explained in greater detail with reference to illustrative embodiments and referring to the figures, in which:

Figure 1 shows the block diagram of a management network for a mobile communications system with agent/manager relation between an operations and maintenance center and one or more network management centers,

GR 98 P 1698

- 7 -

Figure 2 shows the block diagram of the management network according to Figure 1 with agent/manager relation between a base station system and an operations and maintenance center for performing at least two applications for the base station system,

5
Figure 3 shows the block diagram of agent and manager for processing the state information for parameterizable state realignments according to the invention, and

10
Figure 4 shows the message flow between the manager and the agent for controlling the state realignment.

The illustrative embodiment describes the invention by means of a TMN concept for the management of a mobile communication system which, for example, exhibits network facilities of a mobile radio network according to the GSM standard. The invention is not restricted either to the GSM standard or to mobile radio networks but can be applied to telecommunication networks of any type and operation which use a TMN management network.

15
20
25
30
35
A mobile communications system is a hierarchically structured system of various network facilities, in which the lowest hierarchy stage is formed by the mobile stations. These mobile stations communicate with the radio stations forming the next hierarchy level, which are called base stations, via a radio interface. The, for example, mobile stations in a radio area of base stations supplying a radio cell are preferably combined for covering a relatively large radio area and connected to higher-level network facilities, the base station controllers. The base stations and base station controllers belong to a base station subsystem of the mobile communications system. The base station controllers communicate via defined interfaces with

GR 98 P 1698

- 8 -

one or more switching facilities, the mobile switching centers, via which, among other things, the transition to other communication networks also takes place. The mobile switching centers, together with a plurality of data bases, form the switching subsystem of the mobile communications system.

Apart from the above network facilities, there are one or more operation and maintenance centers which are used for, among other things, configuring and monitoring the network facilities. For this purpose, monitoring measures and configuration measures are in most cases remotely controlled from the operation and maintenance center which are usually arranged in the area of the mobile switching centers. In this arrangement, an operation and maintenance center in each case communicates with a base station subsystem or switching subsystem via a defined interface. A further task of the operation and maintenance center is the management of state information (state management) which represents one of a number of management function areas and characterizes the state of a managed object. A managed object is a logical abstraction of a physical resource - i.e. a network facility - in the mobile communications system. In this context, a distinction is made between hardware-related managed objects which describe a manufacturer-related implementation of a function, and function-related managed objects which are in each case the abstraction of a manufacturer-independent functionality.

For the management of the mobile communications system, the TMN principles define a number of levels, of which, in the present example, three levels will be explained in the text which follows, referring to Figures 1 and 2.

Figures 1 and 2 in each case show three levels A, B and C of the management network, of which management level C contains the network element level comprising a number of

GR 98 P 1698

- 9 -

base station subsystems BSS11, BSS12...BSS1N and BSS21, BSS22...BSS2M. Management level B characterizes the network element management level in which the operation and maintenance centers OMC1 and OMC2 in each provide the manufacturer-related management functionality for individual subsystems such as, in the present example, the operation and maintenance center OMC1 for the base station subsystems BSS11, BSS12...BSS1N and the operation and maintenance center OMC2 for the base station subsystems BSS21, BSS22...BSS2M. Management level A characterizes the network management level in which the network management centers NMC1 and NMC2 in each case implement an integrated manufacturer-independent management functionality. In this arrangement, a number of network management centers can have access to the same network facility of the next-lower management level B, in the present example network management centers NMC1 and NMC2 of the next-higher management level C to the operation and maintenance center OMC1 of the next-lower management level B. Between the network facilities of different management levels, defined interfaces are provided for information transfer.

The difference in the illustrations according to Figure 1 and Figure 2 lies in the fact that there is an agent/manager relation for processing state information for one or more state alignments in Figure 1 between the operation and maintenance center OMC1 (agent) and a network management center NMC1 (manager) or a number of - physically separate - network management centers NMC1, NMC2 (manager) and, in Figure 2, between the base station subsystem BSS11 (agent) and two different applications OF1 and OF2 (manager) in the operation and maintenance center OMC1 or between the operation and maintenance center OMC1 (agent) and two different applications NF1 and NF2 (manager) in the network management center NMC1. In

GR 98 P 1698

- 9a -

order to secure an overview of the state of managed objects at any time in the network management centers NMC1, NMC2, the operation and maintenance

GR 98 P 1698

- 10 -

center OMC1 provides the state information - stored on the basis of events and states which have occurred, for example, within the supported base station subsystems BSS11...BSS1N, and sends them on request in parallel to both managers. This is done preferably after a disconnection or after an initialization of the agent or of the manager. Similarly, a number of requests can also be directed successively to the agent, e.g. the operation and maintenance center OMC1, by a single manager, e.g. the network management center NMC1. Figure 1 shows the structure for requests for state realignment sent out a number of times according to the invention, which, in the present example, are running in parallel between management level B in which the agent in the form of the operation and maintenance center OMC1 is located, and the next-higher management level A in which the managers are formed by at least two separate network management centers NMC1, NMC2.

To secure an overview of the state situation at any time also at management level B, e.g. in the operation and maintenance center OMC1, the base station subsystem BSS11 provides the state information - stored on the basis of events and states occurring, for example, within the supported base stations and base station controllers - and sent in parallel to at least two managers of the operation and maintenance center OMC1 in the form of the different applications OF1 and OF2, both of which are executed by one and the same physical facility OMC1. This is also preferably done after a disconnection or after an initialization of the agent or of the manager. A serial transmission of requests initiated several times by a single manager, e.g. the operation and maintenance center OMC1, to the agent, e.g. the base station subsystem BSS11, is also possible. As an alternative, or additionally, an agent/manager relation can also exist between the operation and maintenance center OMC1 (an agent) and the network management center NMC1 (a manager)

GR 98 P 1698

- 11 -

for the serial exchange of requests and state information or for the parallel exchange of requests and state information for at least two different applications NF1 and NF2 (two managers) in the network management center NMC1. Figure 2 shows the structure for state realignments running in parallel according to the invention between management level B, in which the managers are located as applications OF1 and OF2, and the next-lower management level C in which the agent is located.

As soon as an internal interface which has failed in management level C is operational again, the state realignment, also called realignment procedure or realignment method, is started on request of the manager/managers, and only the state information which has changed due to deviations compared with a normal state is transmitted by the agent according to the invention. In the present example, the state realignment begins initially between the base station subsystem, e.g. BSS11, and the applications OF1, OF2 in the operation and maintenance center OMC1 in parallel and then continues in parallel between the operation and maintenance center OMC1 and the higher-level network management centers NMC1, NMC2. At the end of these procedures, the state situation is updated again both in the OMC and in the NMCs and aligned with one another. Naturally, the realignment method can be limited to the updating of the state information between the agent and managers in two immediately adjoining management levels, e.g. level B and level A.

Figure 3 diagrammatically shows the configuration of agent AG and managers MA1, MA2 with the facilities required for carrying out state realignment procedures running simultaneously - in the case of two or more managers - or serially - with only one manager. Each manager MA1, MA2 and agent AG has a controller M-CTR and, respectively, A-CTR which can

GR 98 P 1698

- 11a -

generate and evaluate the messages for the state
realignment.

- 12 -

Similarly, they have transceivers - not shown in greater detail - for sending and receiving the messages and storage facilities for storing the state information and other user and signalling information.

5 The controller M-CTR of the manager then generates a request message by means of which the agent is called up to transmit the state information, and preferably inserts into this request message a correlation information item used for correlating the
10 request with messages transmitted subsequently. This correlation information item issued by the controller M-CTR is unambiguous. The request message is transmitted to the agent via the transceivers. For controlling the state realignment, the M-CTR facility
15 of the manager also includes one or more parameters par in the respective request message in order to selectively request certain state information from selected network facilities. The respective request message is sent together with the parameters par to the
20 agent AG. In particular, the state realignment or realignments can be automated by means of a parameter par so that the controller A-CTR of the agent automatically repeatedly triggers the realignment process within periods defined by a time interval. The
25 parameterizable alignment functionality with regard to the processing of state information makes it possible to achieve, for example, a selection of the resources and/or an active control of the order of the requested information.

30 The controller A-CTR of the agent AG receives the request message containing the parameters par, evaluates them and checks the state information with respect to any deviations from a normal state. If this is so, the controller A-CTR generates one or more
35 messages in which only the changes of the state information for at least one existing object are successively sent back

- 13 -

to the manager MA1, MA2 or, respectively, the controller M-CTR. The state information of managed objects preferably comprises a number of state attributes of which, for example, the attributes OST (operational state), AST (administrative state) and UST (usage state) for identifying the operational readiness, the manageability and the use of a resource supported by the agent and associated with the object in the communication system are specified. The state information preferably also comprises a number of status attributes, of which the attributes UNS (unknown status), ALS (alarm status) and AVS (available status) are defined. In this context, they specify for the respective object or, respectively, for the respective resource in the communication system whether it is in an unknown state (UNS), in an alarm state (ALS) or in a state of availability (AVS).

The state attribute OST can assume the values "enabled" or "disabled", this state information being readable but not changeable from the point of view of the manager. The state attribute AST can assume the values "unlocked by the manager" or "locked by the manager" or "shutting down", the last-mentioned state value having the significance that no further new services will be accepted by the resource in the case of a currently terminated operation. This state information is readable and changeable from the point of view of the manager. The state attribute UST can assume the values "active, free capacity" or "busy, no free capacity" or "idle", this state information being only readable but not changeable from the point of view of the manager. The normal state, which is used for checking the presence of deviations and thus of changed state information is adjustable by means of a default value which is the result of a combination of the above individual values, for example "enabled", "unlocked by the manager" and "idle". This means that

- 13a -

only the changed state information of managed objects,
the state of which differs from the normal state

- 14 -

defined above is transmitted from agent to manager. All other state information, i.e. of objects in the normal state, remains unconsidered and is not transmitted.

Apart from these state attributes, the status
5 attributes UNS, ALS and AVS define in more detailed
form the state of the resource associated with the
object with regard to operational readiness, current
use and manageability. Thus, the status attribute UNS
is set to the value "true" if the state attribute OST
10 or the state attribute AST is not supported. The value
of the respective state attribute OST, AST is
irrelevant in this context. The status attribute ALS
represents an overall indicator for the alarm state of
a resource and is only readable by the manager but
15 cannot be influenced by it. The attribute assumes the
binary value "one" in the case of an alarm state and a
binary value "zero" in the case of the normal state.
The status attribute AVS can assume either no value or
a number of values from a defined set of individual
20 values and can also only be read by the manager. The
normal state is characterized by an empty set of
values.

The state information entered in the storage
device of the agent AG is checked by the controller A-
25 CTR and only the changed state information CST (changed
status) is sent to the controller M-CTR of the manager.

The unambiguous correlation information entered
in the request message by the controller M-CTR of the
manager MA1, MA2 is then used for correlating the
30 requests whilst any further correlation information
item correlates the messages subsequently sent by the
agent (state change notifications) with the state
realignment started in each case. The correlation
information issued by the agent AG or, respectively,
35 its controller A-CTR, is also unambiguous and is sent
to the next-higher management

- 15 -

level preferably in the respective message together with the changed state information cst. Using the correlation information provides for unambiguous correlation of state realignments performed
5 simultaneously or serially with a number of managers or a single manager.

In the agent AG, a number of filter functions EFD1, EFD2 (event forwarding discriminators), which can in each case be associated with the managers MA1, MA2
10 and controlled by them, having filter criteria for the messages generated by the agent AG, can also be used so that the messages with the changed state information cst are only routed to the managers MA1, MA2 when the filter criteria are met. The controller M-CTR of the
15 manager is capable of setting up and deleting such filter functions in the agent AG and of establishing the filter criteria in order to be able to control the message flow in dependence on its individual requirements. The case may therefore occur that the
20 filter function setting is different from manager to manager so that state information with different content is processed by the realignment procedures running simultaneously.

Figure 4 shows the message flow between an
25 agent AG - the operation and maintenance center OMC1 in the example according to Figure 1 shown or the base station subsystem BSS11 in the example of Figure 2 shown - and the manager MA1, MA2 - the different network management centers NMC1, NMC2 in the example
30 according to Figure 1 or the various applications OF1, OF2 in the example of Figure 2.

The message flow preferably takes place by means of standardized M-EVENT-REPORT Services and an M-CREATE Service initiated at the beginning. These are
35 generic CMISE (common management information service element) standardized procedures which are defined according to ITU-T X.710. ITU-T X.731 defines the management of a standardized transmission of

- 16 -

state information which is performed in accordance with the M-EVENT-REPORT services. The correlation information is entered in the messages or, respectively, in particular message fields. 5 Furthermore, the managers MA1, MA2 provide the parameters for controlling the state realignment with certain parameter values and enter them individually or in multiples into the respective request message. The example in Figure 4 shows the message flow by means of 10 individual messages which can be transmitted in parallel between the agent AG and the managers MA1, MA2 or serially between the agent AG and the individual manager MA1.

As soon as the communication between a manager 15 MA1, MA2 and the agent AG is restored after an interruption of the connection, each manager MA1, MA2 sends a request message staAS (start Alignment Scheduler) according to the M-CREATE Service for transmitting the state information to the agent AG for 20 the state realignment. The correlation information staAH (state Alignment Handle) defined by the manager MA1, MA2 is preferably also sent - for example in the defined message field "action information" - which characterizes a direct correlation of the request with 25 the agent messages subsequently received. By this means, the current request can also be allocated to the respective manager in the case of a number of managers so that the parallel realignments of the managers can be initiated, performed and ended independently of one 30 another.

The request message staAS also contains parameter values for the subsequent sequence of functions, entered by the manager. The parameterization can preferably be performed with one or more set 35 parameter values of which the values begT (begin Time), endT (end Time), int (interval), admST (administrative

- 16a -

state) and relEN (related entities) are specified by way of example. The specific parameter values describe:

- 17 -

- a starting time (begT), for example date and clock time, for an automatic state realignment and/or an end time (endT), for example date and clock time, for the automatic state realignment,
- 5 - a time interval (int), for example in minutes, hours, days etc. for repeating the automatic state realignment,
- selected resources (relEN) for which the changed state information is to be transmitted by the agent,
- 10 - the discontinuation (admST) of a running state realignment, a recontinuation of the alignment procedure also being possible with the value admST=unlock. The parameter values begT...admST are contained in a message field, predetermined in accordance with
- 15 the standard, of the M-CREATE service so that preexisting and defined fields can also be used.

Following the evaluation of the parameters in the received request message staAS, the agent checks whether there are changes in the state information by

20 means of deviations compared with the normal state and edits the changed state information for each managed object which is not in the normal state. This is preferably done by means of the state and status attributes according to the description relating to

25 Figure 3. The agent AG continues the state realignment by generating a start message stSA (start State Alignment) and inserting the correlation information aliNI (alignment Notification Id) defined by it into this message. The correlation information item staAH

30 issued and transmitted by the manager is also contained in a particular message field of the start message stSA. The correlation information aliNI is entered, for example, in the standardized message field "notification identifier" of the message stSA. Both

35 information items staAH, aliNI are sent out together in the message stSA to the managers MA1, MA2 by the agent AG. As a result, "alignment-related" M-EVENT-REPORT messages of different M-CREATE requests

- 17a -

can be distinguished from one another but also from
regular

- 18 -

M-EVENT-REPORT messages which have nothing to do with the state realignment. This is because an alignment procedure does not necessarily stop other M-EVENT-REPORT messages which occur spontaneously during the alignment procedure and are sent to the manager or managers.

After the automatic start of the state realignment - preferably controlled by the manager MA1, MA2 by means of at least one parameter - the agent AG only returns the edited changed state information cst to the requesting manager MA1, MA2 in successive staCN (state Change Notification) messages by using the M-EVENT-REPORT service. In a staCN message, only the state changes found for an object and its associated resource are preferably transmitted so that in the case of a number of objects which may be different, a number of staCN messages are also needed. In this context, each staCN message exhibits the correlation information item aliNI - for example in the defined message field "correlated notifications". After the last M-EVENT-REPORT message of each state realignment, the agent AG generates an end message endA (end alignment) which contains the correlation information item aliNI. In a case where all managed objects are in the normal state at the time of the M-CREATE Service or when the messages with the state changes are filtered out by the current filter settings, the end message endA directly follows the start message stSA. The above message flow is repeated for each state alignment until the end of the automatic state realignment is reached which can be seen from the parameter value endT. Even if the example described with respect to Figure 4 relates to parallel realignments with a number of managers, the message flow can naturally also be applied to a number of requests, triggered successively by a single manager, for processing state information in accordance with the "state alignment". This has the

- 18a -

advantage that, due to the unambiguous correlation by means of the correlation

- 19 -

information, the individual manager has the capability of being able to allocate the incoming responses of the agent unambiguously to the requests - for example different applications in the manager - even if the order is not maintained. Successively sent requests may overtake each other, for example if a packet network is traversed between agent and manager.

Patent claims

1. Method for processing state information in a communication system by means of a management network exhibiting a number of management levels (A, B, C), the state information being transmitted between an agent (AG) of one management level (B, C) and at least one manager (MA1, MA2) of a next-higher management level (A, B) for a state realignment, in which method
 - 5 - the manager (MA1, MA2) sends a request message (staAS) for performing the state realignment to the agent (AG),
 - the agent (AG) checks the state information with regard to deviations from a normal state, and
 - 15 - the agent (AG) sends changes in the state information to the manager (MA1, MA2) in one or more successive messages (staCN).
2. The method as claimed in claim 1, in which state attributes (OST, AST, UST) and/or status attributes (UNS, ALS, AVS) are used as state information.
- 20 3. The method as claimed in claim 2, in which the normal state is defined by means of predeterminable values for the state attributes (OST, AST, UST) and/or status attributes (UNS, ALS, AVS).
- 25 4. The method as claimed in one of the preceding claims, in which state attributes (OST, AST, UST) for characterizing the operational readiness, the manageability and the use of a resource supported by the agent (AG) in the communication system is used as state information.
- 30 5. The method as claimed in one of the preceding claims, in which status attributes (UNS, ALS, AVS), which specify for a resource supported by the agent (AG) in the communication system whether it is in an unknown state, in an alarmed state or
- 35

- 21 -

in a state of availability, is used as state information.

6. The method as claimed in one of the preceding claims, in which the manager (MA1, MA2) also sends in
5 the request message (staAS) a correlation information item (staAH) for a correlation of the respective request with the messages (staCN) containing the changed state information received by the agent (AG).

7. The method as claimed in one of the preceding
10 claims, in which the agent (AG) also sends in a message (staSA) for starting the state realignment a correlation information item (aliNI) for correlating the messages (staCN) containing the changed state information subsequently sent with the state
15 realignment started in each case.

8. The method as claimed in claim 7, in which the correlation information (aliNI) generated by the agent (AG) is also sent in the message or messages (staCN) containing the changed state information.

9. The method as claimed in one of the preceding
20 claims, in which the manager (MA1, MA2) controls the state realignment in dependence on at least one parameter (par) sent to the agent (AG).

10. The method as claimed in one of the preceding
25 claims, in which the manager (MA1, MA2) sends a parameter (par) by means of which the state realignment is automatically initiated by the agent (AG).

11. The method as claimed in claim 10, in which a parameter (par) is provided by the manager (MA1, MA2)
30 with a parameter value (begT) which specifies a starting time for the automatic state realignment.

- 22 -

12. The method as claimed in claim 10 or 11, in which a parameter (par) is provided by the manager (MA1, MA2) with a parameter value (endT) which specifies an end time for the automatic state
5 realignment.

13. The method as claimed in one of claims 10 to 12, in which the manager (MA1, MA2) provides a parameter (par) with a parameter value (int) which specifies a time interval for a repetition of the
10 automatic state realignment.

14. The method as claimed in one of claims 9 to 13, in which the manager (MA1, MA2) provides a parameter (par) with a parameter value (reLEN) which characterizes the resources for which changed state
15 information must be transmitted by the agent (AG).

15. The method as claimed in one of claims 9 to 14, in which the manager (MA1, MA2) provides a parameter (par) with a parameter value (admS) by means of which a running state realignment can be interrupted.

20 16. The method as claimed in one of Claims 9 to 15, in which the manager (MA1, MA2) sends the parameter or parameters (par) to the agent (AG) in the request message (staAS).

25 17. A communication system for processing state information in a management network having a number of management levels (A, B, C), the state information being transmitted between an agent (AG) of a management level (e.g. B) and at least one manager (MA1, MA2) of a next-higher management level (e.g. A) for a state
30 realignment, comprising

- facilities (M-CTR) in the manager (MA1, MA2) for sending a request message (staAS) for performing the state realignment to the agent (AG), and

- 23 -

- facilities (A-CTR) in the agent (AG) for checking the state information with regard to deviations from a normal state and for sending changes in the state information to the manager (MA1, MA2) in one or more successive messages (staCN).

18. The communication system as claimed in claim 17, in which state attributes (OST, AST, UST) and/or status attributes (UNS, ALS, AVS) are provided as state information.

10 19. The communication system as claimed in claim 18, in which the normal state is defined by means of predetermined values for the state attributes (OST, AST, UST) and/or status attributes (UNS, ALS, AVS).

15 20. The communication system as claimed in one of claims 17 to 19, in which state attributes (OST, AST, UST) are provided for characterizing the operational readiness, the manageability and the use of a resource supported by the agent (AG) in the communication system as state information.

20 21. The communication system as claimed in one of claims 17 to 20, in which status attributes (UNS, ALS, AVS), which specify for a resource supported by the agent (AG) in the communication system whether it is in an unknown state, in an alarm state or in a state of availability, are provided as state information.

25 22. The communication system as claimed in one of claims 17 to 21, in which the state realignment can be controlled by the facilities (M-CTR) in the manager (MA1, MA2) in dependence on at least one parameter (par) sent to the agent (AG).

30 23. The communication system as claimed in one of claims 17 to 22, in which the facilities (M-CTR) in the manager (MA1, MA2) send a parameter (par) by means of which

- 24 -

the state realignment can be automatically initiated by the agent (AG).

Fetherstonhaugh & Co.
Ottawa, Canada
Patent Agents

1/2

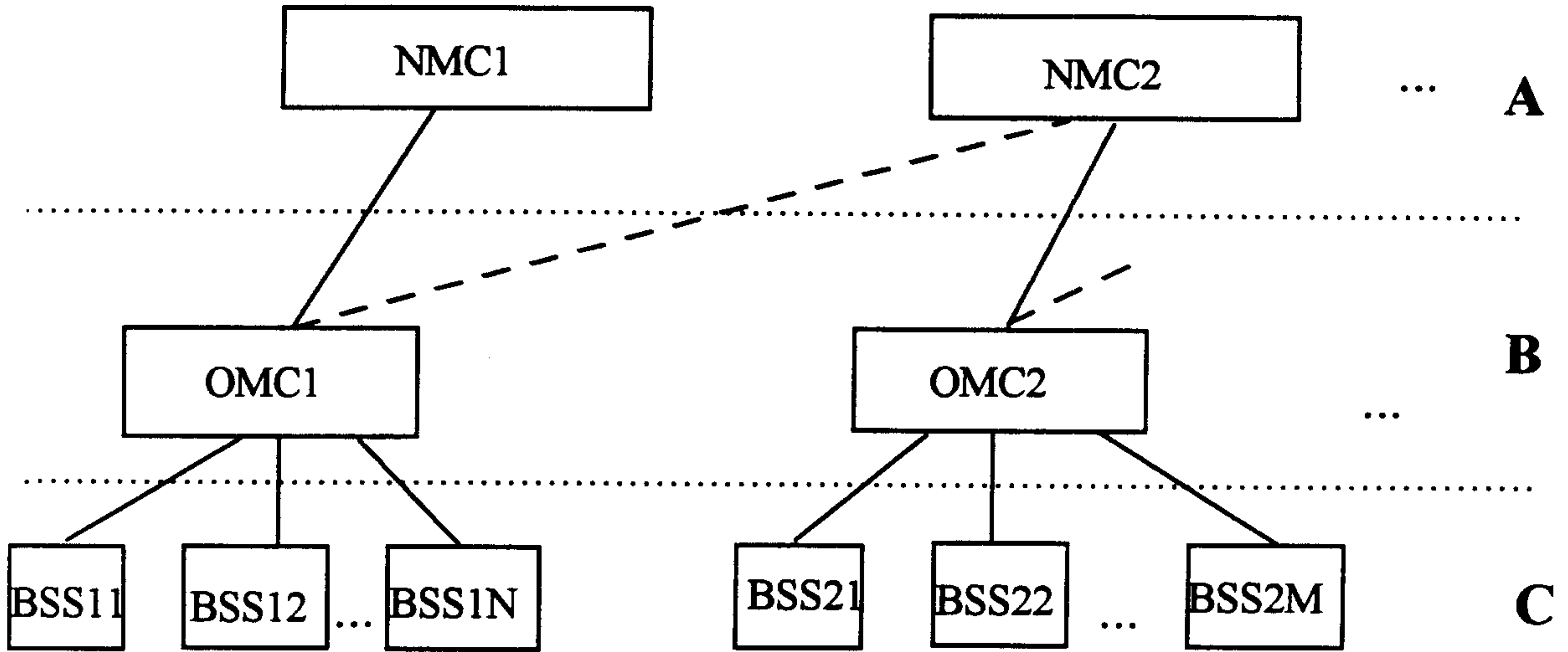

FIG 1

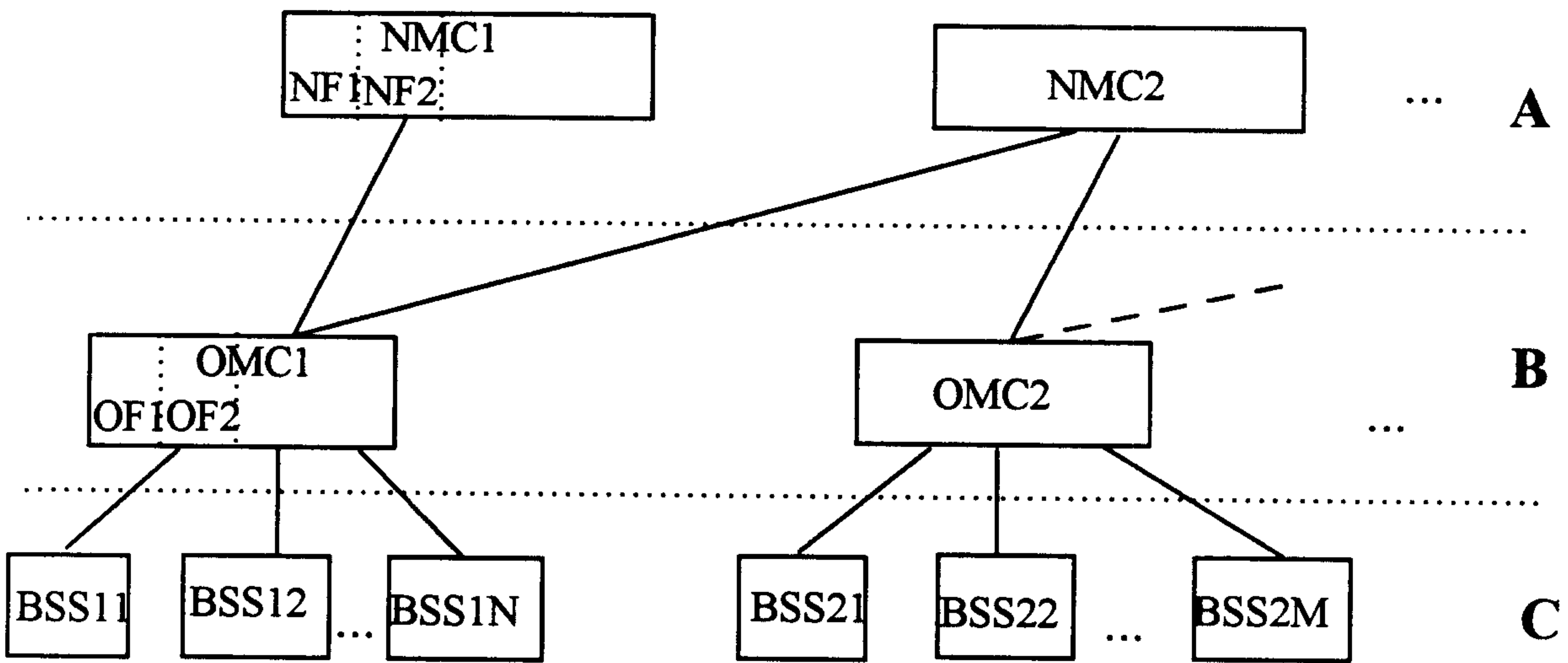

FIG 2

2/2

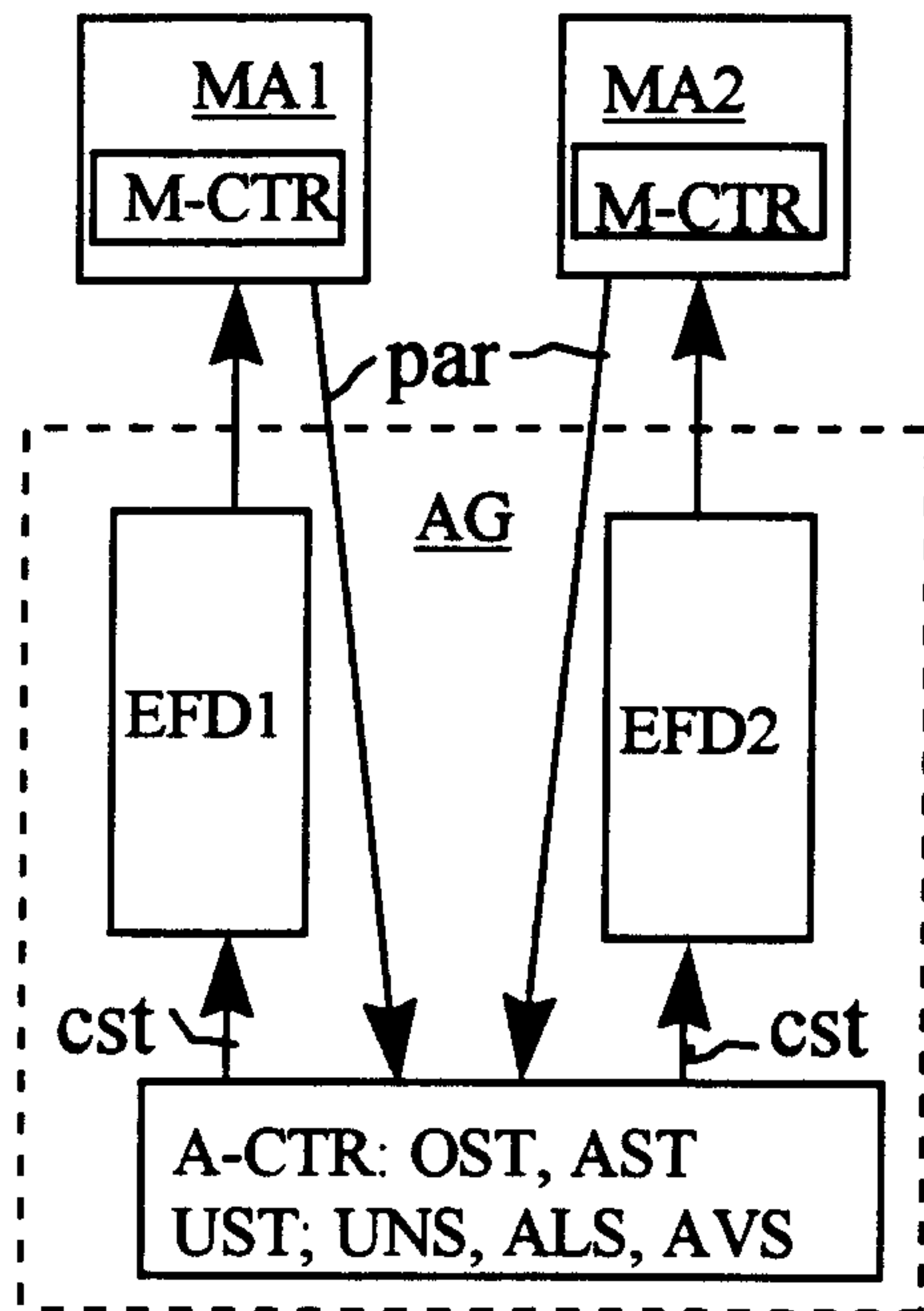

Fig. 3

FIG 3

MA1/MA2

NMC1/
NMC2

OF1/
OF2

AG

OMC1

BSS11

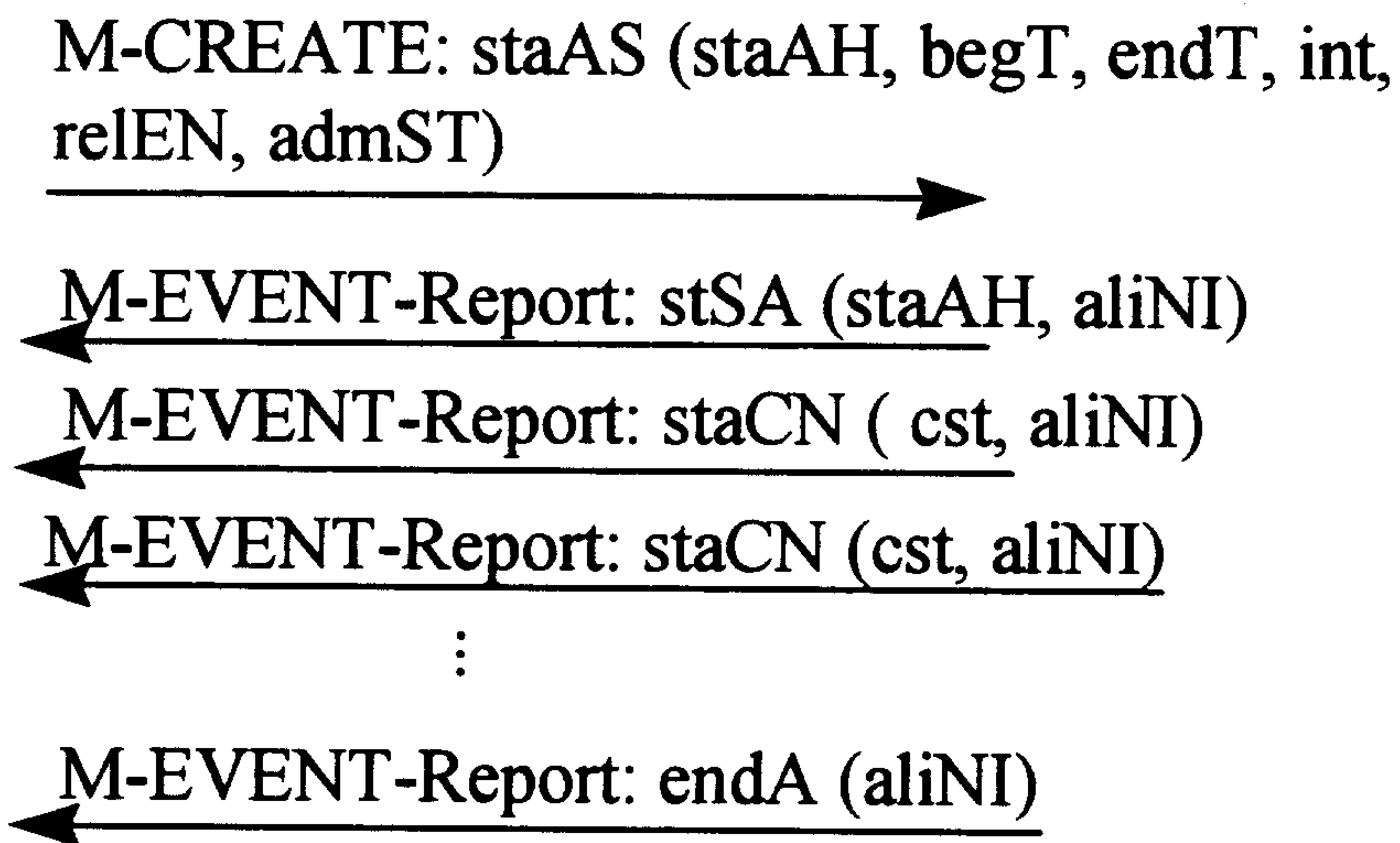

FIG 4

