

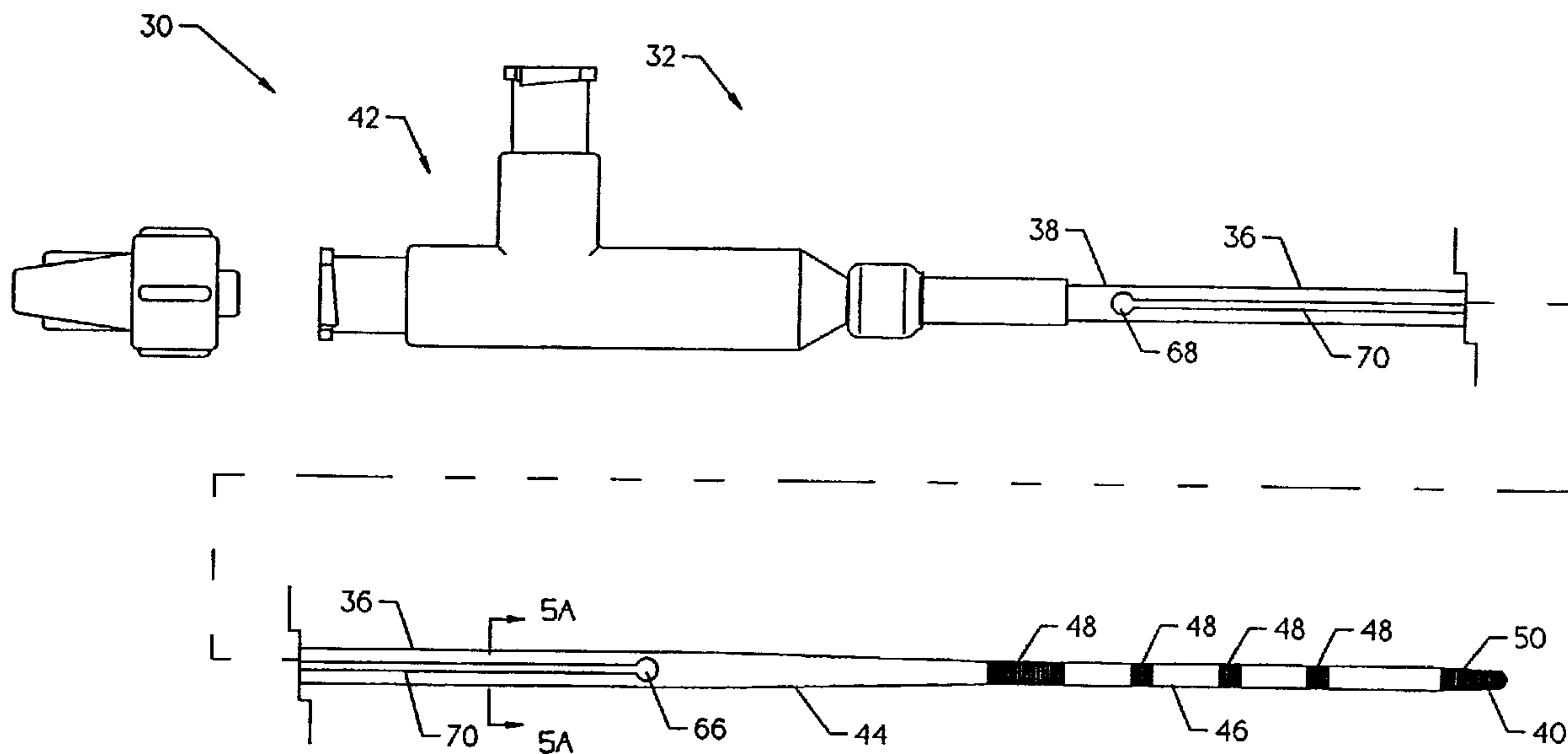

(86) Date de dépôt PCT/PCT Filing Date: 1997/09/10  
 (87) Date publication PCT/PCT Publication Date: 1998/03/19  
 (45) Date de délivrance/Issue Date: 2007/09/18  
 (85) Entrée phase nationale/National Entry: 1999/03/03  
 (86) N° demande PCT/PCT Application No.: US 1997/016005  
 (87) N° publication PCT/PCT Publication No.: 1998/010820  
 (30) Priorités/Priorities: 1996/09/13 (US025,235);  
 1997/09/09 (US926,390)

(51) Cl.Int./Int.Cl. *A61M 25/01* (2006.01)  
 (72) Inventeurs/Inventors:  
 AGRO, MARK, US;  
 LEVENDUSKY, JOSEPH, US;  
 WARICH, CHARLES, US;  
 PAILLE, RONALD, US  
 (73) Propriétaire/Owner:  
 BOSTON SCIENTIFIC CORPORATION, US  
 (74) Agent: OYEN WIGGS GREEN & MUTALA LLP

(54) Titre : CATHETER BILIAIRE POUVANT ETRE REMPLACE PAR UN SEUL OPERATEUR  
 (54) Title: SINGLE OPERATOR EXCHANGE BILIARY CATHETER



(57) **Abrégé/Abstract:**

Catheter for use in biliary procedures, including a shaft having a proximal end and a distal end. A guidewire lumen is carried by the shaft extending from a location proximal the distal end of the shaft to a location proximate the distal end of the shaft. An opening is included for accessing the guidewire lumen from a location exterior the catheter shaft located distal the proximal end of the shaft. The guidewire lumen may be formed integral the catheter shaft. The catheter may be used in rapid exchange catheter procedures. The catheter may further include a port and channel design including a first opening into the guidewire lumen located proximal the distal end of the shaft, a second opening located proximal the first opening, and a channel extending longitudinally between the first opening and the second opening.



PCT

WORLD INTELLECTUAL PROPERTY ORGANIZATION  
International Bureau

## INTERNATIONAL APPLICATION PUBLISHED UNDER THE PATENT COOPERATION TREATY (PCT)

<p>(51) International Patent Classification <sup>6</sup> : <b>A61M 25/01</b></p>	<p><b>A1</b></p>	<p>(11) International Publication Number: <b>WO 98/10820</b></p> <p>(43) International Publication Date: 19 March 1998 (19.03.98)</p>						
<p>(21) International Application Number: PCT/US97/16005</p> <p>(22) International Filing Date: 10 September 1997 (10.09.97)</p> <p>(30) Priority Data:</p> <table border="0"> <tr> <td>025,235</td> <td>13 September 1996 (13.09.96)</td> <td>US</td> </tr> <tr> <td>926,390</td> <td>9 September 1997 (09.09.97)</td> <td>US</td> </tr> </table> <p>(71) Applicant: BOSTON SCIENTIFIC CORPORATION [US/US]; One Boston Scientific Place, Natick, MA 01760-1537 (US).</p> <p>(72) Inventors: AGRO, Mark; 13 King Philip Path, Mendon, MA 01756 (US). LEVENDUSKY, Joseph; 34 Nashua Road, Groton, MA 01450 (US). WARICH, Charles; 5 Geneso Circle, Milford, MA 01757 (US). PAILLE, Ronald; 38 Prescott Street, Attleboro, MA 02703 (US).</p> <p>(74) Agents: CROMPTON, David, M. et al.; Nawrocki, Rooney &amp; Sivertson, P.A., Suite 401, 3433 Broadway Street N.E., Minneapolis, MN 55413 (US).</p>		025,235	13 September 1996 (13.09.96)	US	926,390	9 September 1997 (09.09.97)	US	<p>(81) Designated States: AL, AM, AU, BB, BG, BR, CA, CN, CZ, EE, FI, GE, HU, IS, JP, KG, KP, KR, LK, LR, LT, LV, MD, MG, MK, MN, MX, NO, NZ, PL, RO, SG, SI, SK, TR, TT, UA, UZ, VN, ARIPO patent (GH, KE, LS, MW, SD, SZ, UG, ZW), Eurasian patent (AM, AZ, BY, KG, KZ, MD, RU, TJ, TM), European patent (AT, BE, CH, DE, DK, ES, FI, FR, GB, GR, IE, IT, LU, MC, NL, PT, SE), OAPI patent (BF, BJ, CF, CG, CI, CM, GA, GN, ML, MR, NE, SN, TD, TG).</p> <p><b>Published</b> <i>With international search report.</i></p>
025,235	13 September 1996 (13.09.96)	US						
926,390	9 September 1997 (09.09.97)	US						

(54) Title: SINGLE OPERATOR EXCHANGE BILIARY CATHETER

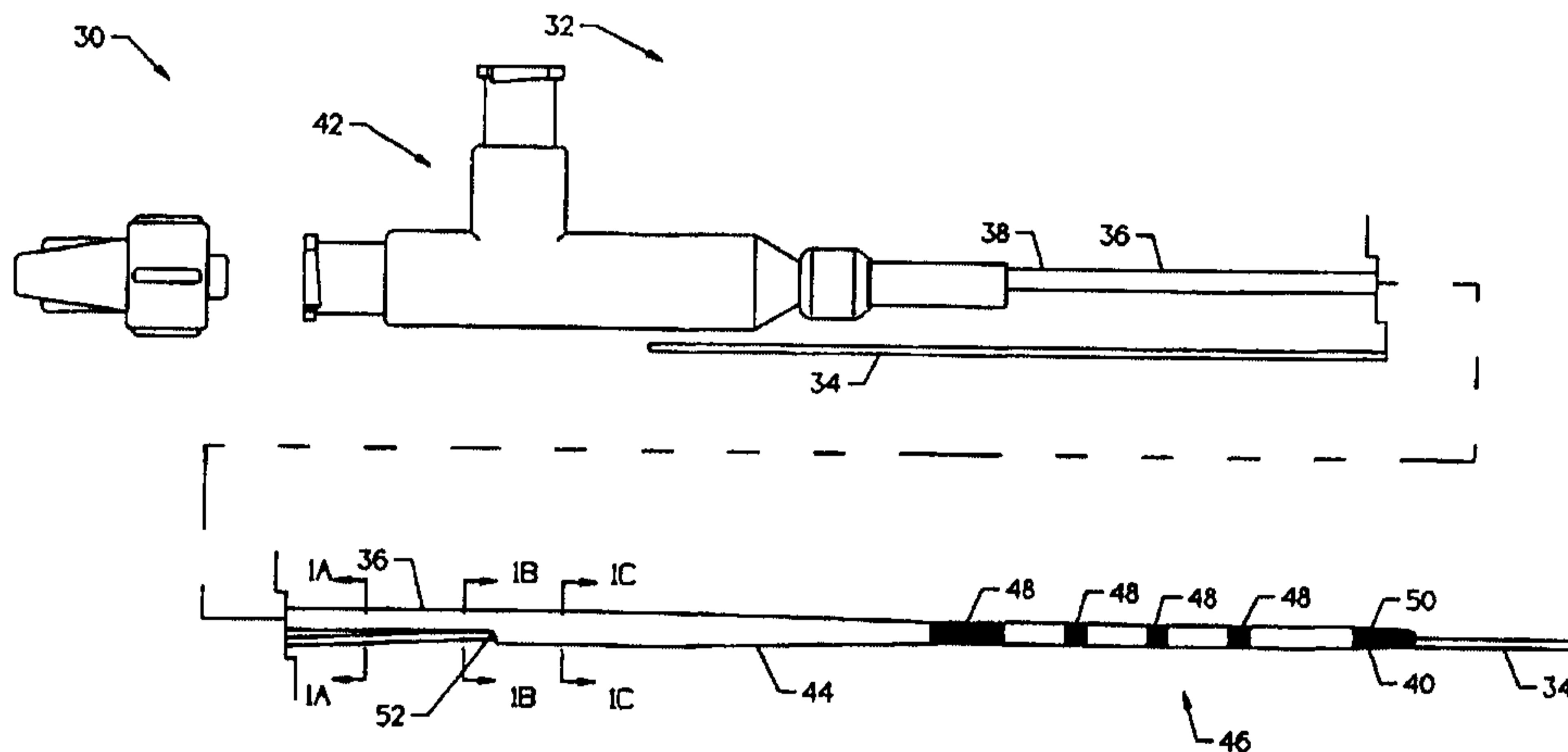

## (57) Abstract

Catheter for use in biliary procedures, including a shaft having a proximal end and a distal end. A guidewire lumen is carried by the shaft extending from a location proximal the distal end of the shaft to a location proximate the distal end of the shaft. An opening is included for accessing the guidewire lumen from a location exterior the catheter shaft located distal the proximal end of the shaft. The guidewire lumen may be formed integral the catheter shaft. The catheter may be used in rapid exchange catheter procedures. The catheter may further include a port and channel design including a first opening into the guidewire lumen located proximal the distal end of the shaft, a second opening located proximal the first opening, and a channel extending longitudinally between the first opening and the second opening.

**SINGLE OPERATOR EXCHANGE BILIARY CATHETER**Field of the Invention

5 The present invention relates to catheters for use in  
catheter procedures accessed through the alimentary canal  
within the human anatomy and methods of using such  
catheters. The catheter is particularly useful in  
conjunction with an endoscope for accessing the biliary  
tree. The present invention includes a catheter having  
single operator exchange or rapid exchange features which  
10 permit the use of shorter guidewires, allow less time  
consuming procedures, and allow for larger diameter  
ancillary lumens within the catheter.

Description of the Prior Art

15 Endoscopic procedures for treating abnormal pathologies  
within the alimentary canal system and biliary tree  
(including the biliary, hepatic, and pancreatic ducts) are  
increasing in number. The endoscope provides access to the  
general area of a desired duct using direct visualization,  
20 however, the duct itself must be navigated using a catheter  
in conjunction with fluoroscopy and guidewires.

Catheters are known for treatment of targeted  
anatomical regions. Known methods and devices for using  
biliary catheters for accessing the biliary tree for  
25 performing catheter procedures are disclosed in Weaver et  
al., U. S. Patent No. 5,397,302 and Karpziel, U.S. Patent No.  
5,320,602.

In general, for treatment of an abnormal pathology  
within a patient's biliary tree, an endoscope is first  
30 introduced into the mouth of the patient. The endoscope  
includes a proximal end and a distal end, and has a lumen  
extending longitudinally between the proximal and the  
distal ends. The endoscope is guided through the patient's  
alimentary tract or canal until an opening at the distal  
35 end of the endoscope is proximate the location for gaining  
access to the area to receive treatment. At this point, the  
endoscope allows for other components, such as a catheter,  
to access the targeted area.



For visualization or treatment within the biliary tree, the distal end of the endoscope is positioned proximate the papilla of Vater leading to the common bile duct and the pancreatic duct. A catheter is guided through the lumen of the endoscope until a distal tip of the catheter emerges from the opening at the distal end of the endoscope.

The catheter may be used for accessing the biliary tree. The distal end of the catheter is guided through the orifice to the papilla of Vater (located between the sphincter of Oddi) leading to the common bile duct and the pancreatic duct. A guidewire may be used for further accessing a desired location within the biliary tree. The guidewire is inserted in an opening at a proximal end of the catheter and guided through the catheter until it emerges from the distal end of the catheter.

If visualization of the common bile duct is desired, the guidewire is guided into the common bile duct. The catheter is advanced over the guidewire, as previously described, until the distal end of the catheter is positioned in the common bile duct at the desired location. The catheter is now in position for delivery of contrast media for fluoroscopic visualization of anatomical detail within the common bile duct. Once the guidewire is placed, it is desirable to maintain position of the guidewire during subsequent catheter procedures, including catheter exchange procedures.

Present biliary endoscopic procedures include the use of multi-lumen catheters for endoscopic retrograde cholangiopancreatography, endoscopic retrograde sphincterotomy, the use of balloon catheters having retrieval balloons, and other therapeutic and diagnostic procedures. As described in general above, these present biliary endoscopic procedures are performed using guidewire techniques. The present devices utilized in these procedures are at least 180 cm long since they pass through the endoscope, which is commonly at least 150 cm long.

Therefore, when using a standard catheter having a guidewire lumen extending the full length of the catheter, guidewires used during these procedures must be at least 400 cm in length to accommodate the exchanging of different devices while maintaining access and position within the biliary tree. The exchange of devices over a 400 cm guidewire is both time consuming and cumbersome.

Due to the length of the guidewire, physicians require at least two assistants in the room to perform the biliary endoscopic procedure. Typically, one assistant is responsible for the patient and device-related concerns, while the other assistant is responsible for the guidewire. The additional hands required due to the length of the guidewire results in a relatively more time consuming and costly procedure.

It is desirable to have an exchange catheter suitable for use within the alimentary canal for accessing targeted anatomical regions, such as the biliary tree, having features which facilitate rapid exchange and allow an exchange procedure to be performed by a single operator. It is desirable to have a biliary exchange catheter which may be used in connection with a shorter guidewire, and requires less personnel for performing biliary procedures. It is desirable to have a biliary exchange catheter which limits the amount of guidewire over which the catheter must travel.

It is also desirable to have a biliary rapid exchange catheter which may be convertible for use between conventional guidewire techniques and rapid exchange guidewire techniques. It is desirable to have a biliary rapid exchange catheter which is easily removable from the guidewire, and adaptable for use with most catheter systems used within the alimentary canal.

#### Summary of the Invention

The present invention relates to a biliary catheter for use in biliary endoscopic procedures which incorporates rapid exchange catheter features. Rapid exchange features



include an effective guidewire lumen which is much shorter than the overall catheter length to facilitate rapid exchange of the device over the guidewire.

5 In one preferred embodiment, the present invention is an improved catheter for use in biliary procedures which includes a shaft having a proximal end and a distal end. The improvement includes a guidewire lumen carried by the shaft extending from a location proximal of the distal end of the shaft to a location proximate the distal end of the shaft. Means are provided for accessing the guidewire lumen from a location exterior to the catheter shaft, located a substantial distance distal of the proximal end of the shaft.

15 The guidewire lumen may be formed integral with the shaft. The means for accessing the guidewire lumen may include an opening extending through the wall of the catheter shaft. Additionally, the wall of the catheter shaft defined by the guidewire lumen may include a relatively weak area extending longitudinally between the opening and the distal end of the shaft. The weak area may be perforated. The catheter may further include a tool for guiding a guidewire through the opening into the guidewire lumen.

20 In a further preferred embodiment, the means for accessing the lumen may include a slit in the wall of the catheter shaft. An ancillary lumen may extend between the catheter proximal end and the catheter distal end.

25 In one embodiment, the means for accessing the guidewire lumen includes a first opening or intermediate guidewire port through the wall of the catheter shaft into the guidewire lumen located proximal of the distal end of the shaft. A second opening or proximal guidewire port into the guidewire lumen is located proximal of the first opening. A channel extends between the first opening and the second opening. The channel includes a longitudinal opening to the exterior of the catheter shaft extending between the first opening and the second opening in

communication with the guidewire lumen. The longitudinal opening preferably is smaller than the diameter of a guidewire used therewith.

5 In another embodiment, the present invention is a biliary rapid exchange catheter. The biliary rapid exchange catheter includes a biliary catheter sized for passage within an endoscope including a shaft having a proximal end and a distal end. The biliary catheter includes a tubular member having a proximal end, a distal end, and a guidewire lumen extending longitudinally therethrough which extends between a location proximate the distal end of the shaft (a distal port) to a location proximal of the distal end of the shaft (a proximal port). The proximal port is provided in communication with the guidewire lumen, at a location proximal of the distal end of the shaft.

10 The proximal port may be located at the proximal end of the tubular member. The guidewire lumen may then extend between the proximal end and the distal end of the shaft. The guidewire lumen would then include a weakened area extending longitudinally between the proximal port and the distal end of the shaft. The biliary catheter may further include an ancillary lumen extending between the proximal end and the distal end of the shaft.

20 The biliary catheter may alternatively include an intermediate port into the guidewire lumen at a longitudinal location between the proximal port and the distal end of the shaft or distal port. Means are included extending longitudinally between the proximal port and the intermediate port for allowing a guidewire to be moved between a location exterior of the guidewire lumen to a location within the guidewire lumen between the proximal and intermediate ports. The means for allowing the guidewire to be moved between a location exterior the guidewire lumen and within the guidewire lumen include an open channel extending longitudinally between the proximal port and the intermediate port.



5 The means for allowing the guidewire to be moved between a location exterior the guidewire lumen and within the guidewire lumen may include a weakened portion within the tubular member extending longitudinally between the proximal port and the intermediate port. The weakened portion may be perforated.

10 In another embodiment, the present invention includes a method of positioning a biliary catheter including a shaft having a proximal end and a distal end, within a patient's alimentary canal. The method includes the step of providing a catheter with a guidewire lumen therein. The guidewire lumen extends from a location proximal of the distal end of the shaft to a location proximate the distal end of the shaft. A port is provided through a sidewall of  
15 the shaft into the guidewire lumen. The port is located distal of the proximal end of the shaft. The method further includes the step of moving a guidewire through the port, relative to the shaft. The method may further include the step of advancing the catheter over the  
20 guidewire.

In another embodiment, the present invention includes a method of exchanging a catheter during a biliary endoscopic procedure. The method includes the step of passing an endoscope having a lumen extending  
25 longitudinally therethrough, through a patient's mouth into the alimentary canal. A distal end of the endoscope is positioned proximate an opening into the biliary tree. A guidewire is passed through the lumen of the endoscope.

30 A catheter is provided having a guidewire lumen carried by the shaft, extending from a location proximal of a distal end of the shaft to a location proximate the distal end of the shaft. A first opening is included into the guidewire lumen, located distal of the proximal end of the shaft. The catheter is advanced over the guidewire,  
35 wherein a proximal end of the guidewire exits the first opening.

The method may further include retracting the catheter



over the guidewire. In one embodiment, wherein the catheter is retracted over the guidewire until the opening is outside the proximal end of the endoscope, the catheter has a weakened area extending longitudinally between the opening and the distal end of the catheter. The method further comprises the step of peeling the catheter away from the guidewire.

The catheter may further include a second opening or intermediate opening into the guidewire lumen. A channel extends longitudinally between the first opening and the second opening. The method further comprises the step of passing the guidewire radially through the channel opening while inserting or retracting the catheter until the guidewire exits the second opening.

#### Brief Description of the Drawings

The invention will be further described with reference to the accompanying drawings, wherein like numbers refer to like parts in several views and wherein:

Fig. 1 is a partial elevational view of a catheter in accordance with the present invention having a guidewire lumen for facilitating rapid catheter exchange with a guidewire passing therethrough;

Fig. 1A is a cross-sectional view of the catheter of Fig. 1 taken along line 1A-1A;

Fig. 1B is a cross-sectional view of the catheter of Fig. 1 taken along line 1B-1B;

Fig. 1C is a cross-sectional view of the catheter of Fig. 1 taken along line 1C-1C;

Fig. 1D is a cross-sectional view of an alternative embodiment of the catheter of Fig. 1 in accordance with the present invention, also taken along line 1C-1C;

Fig. 1E is a partial elevational view of an alternative embodiment of the catheter in accordance with the present invention;

Fig. 1F is a cross-sectional view of the catheter of Fig. 1E taken along line 1F-1F;

Fig. 2 is a partial elevational view of another

embodiment of the catheter in accordance with the present invention;

Fig. 3 is a partial elevational view of another embodiment of the catheter in accordance with the present invention;

Fig. 3A is a cross-sectional view of the catheter of Fig. 3 taken along line 3A-3A;

Fig. 3B is a cross-sectional view of the catheter of Fig. 3 taken along line 3B-3B;

Fig. 4 is a partial elevational view of another embodiment of the catheter in accordance with the present invention;

Fig. 4A is a cross-sectional view of the catheter of Fig. 4 taken along line 4A-4A;

Fig. 4B is a cross-sectional view of the catheter of Fig. 4 taken along line 4B-4B;

Fig. 5 is a partial elevational view of another embodiment of the catheter in accordance with the present invention;

Fig. 5A is a cross-sectional view of the catheter of Fig. 5 taken along line 5A-5A;

Fig. 6 is a different partial elevational view of the catheter of Fig. 5 having a guidewire disposed therein;

Fig. 6A is a cross-sectional view of the catheter of Fig. 6 taken along line 6A-6A showing the guidewire received within the lumen of Fig. 5;

Fig. 7 is a partial elevational view of a catheter assembly showing a guidewire loading tool for use in conjunction with the catheter of Figs. 5 and 6;

Fig. 7A is an alternative partial elevational view of the catheter assembly of Fig. 7 showing an application of the present invention;

Fig. 7B is a partial cross-sectional view of the catheter of Fig. 7 taken along line 7B-7B, showing a first guidewire tool position;

Fig. 7C is a partial elevational view of a catheter assembly showing an application of the present invention;



Fig. 7D is a partial cross-sectional view of the catheter of Fig. 7 taken along line 7B-7B showing a second guidewire tool position;

5 Fig. 7E is a partial elevational view of a catheter assembly showing an application of the present invention;

Fig. 7F is a partial cross-sectional view of the catheter of Fig. 7 taken along line 7B-7B, showing a third guidewire tool position;

10 Fig. 7G is a partial elevational view of a catheter assembly showing an application of the present invention;

Fig. 7H is a partial cross-sectional view of the catheter of Fig. 7 taken along line 7B-7B, showing a fourth guidewire tool position; and

15 Fig. 8 is a partial elevational view of a catheter showing another application of the present invention;

Fig. 9 is a partial elevational view of a catheter showing another application of the present invention;

#### Detailed Description of the Preferred Embodiments

20 Fig. 1 shows a partial elevational view of a catheter assembly 30 in accordance with the present invention. The catheter assembly 30 is used in catheter procedures for accessing targeted anatomical regions through the alimentary canal. The present invention incorporates features which allow rapid exchange of catheter by a single operator. The catheter of the present invention allows shorter length guidewires to be used, resulting in procedures which require less medical personnel, are less time consuming, and less costly. Additionally, the present invention is adaptable to most catheter devices used for catheter procedures within the alimentary canal.

25 30 35 Catheter assembly 30 includes a catheter 32 having a guidewire 34 passing through a portion thereof. Catheter 32 includes a shaft 36 having a proximal end 38 and a distal end 40. Operably connected to the proximal end 38 of the shaft 36 is a hub assembly 42. Hub assembly 42 couples to ancillary devices allowing access to a lumen within shaft 36. Shaft 36 is preferably formed in an

extrusion process. Shaft 36 may be formed of an extruded polymeric material. In one embodiment, the preferred polymeric material is polytetrafluoroethylene, polyether block amide, nylon or a combination or blend of these. Catheters which are contemplated include, but are not limited to, cannulas, sphinctertomes, cytology devices, and devices for stone retrieval and stent placement.

Shaft 36 is a generally tubular shaped member having a generally uniform outer shape at its proximal end. Shaft 36 may be sized for slidable passage through the lumen of an endoscope. Shaft 36 includes a distal taper 44 which tapers to a tip region 46. Tip region 46 may include high contrast, color coded distal markers 48, and a radiopaque distal tip 50 for fluoroscopic visualization of tip region 46 during a catheter procedure.

Shaft 36 further includes a proximal port or opening 52 located proximal of distal end 40. Proximal opening 52 allows access to shaft 36 for passage of guidewire 34 through shaft 36. Fig. 1A is a cross-sectional view of shaft 36 taken along line 1A-1A at a location proximal of proximal opening 52. Proximal to proximal opening 52, guidewire 34 is positioned adjacent the catheter shaft 36.

Extending longitudinally between the shaft proximal end 38 and distal end 40 is an ancillary lumen 54 and an ancillary lumen 56. Ancillary lumen 54 and ancillary lumen 56 may be injection lumens, allowing for high contrast media flow capability for bubble-free opacification and for excellent visualization of a desired anatomical region. Additionally or alternatively, ancillary lumen 54 and/or ancillary lumen 56 may be used for other ancillary devices, such as a cutting wire lumen or a retrieval balloon lumen.

Referring to Fig. 1B, a cross-sectional view of shaft 36 taken along line 1B-1B of Fig. 1 is shown. A guidewire lumen 58 extends between proximal opening 52 and distal end 40. Guidewire 34 may enter guidewire lumen 58 at proximal opening 52. Guidewire lumen 58 is sized for slidable



receipt and passage of guidewire 34 through guidewire lumen 58. Referring to Fig. 1C, guidewire lumen 58 extends through distal taper 44 and tip region 46.

5 Although it is recognized that proximal opening 52 may be located at any location distal of proximal end 38, proximal opening 52 is preferably located between 10 and 40 cm from distal end 40. Guidewire lumen 58 is a tubular member which is carried adjacent shaft 36 ancillary lumen 54 and ancillary lumen 56. Guidewire lumen 58 may be  
10 formed integral with shaft 36, or alternatively, guidewire lumen 58 may be part of a separate tubular member which is coupled to the shaft 36 as shown in Fig. 1D.

Now referring to Figs. 1E and 1F, an alternative embodiment of the catheter depicted in Fig. 1 is  
15 illustrated. The catheter shaft 36 of Fig. 1E incorporates a proximal guidewire opening which, in conjunction with the catheter, forms a circular cross section which allows for easy insertion of the guidewire. As depicted in Fig. 1F, the guidewire lumen 58 can include  
20 a larger proximal opening which funnels down to the size of the guidewire lumen 58 which extends distal to the distal end of the catheter shaft 36.

Guidewire lumen 58 allows rapid exchange of catheter 32 when an alternative catheter is necessary during a  
25 procedure. Shorter length guidewires may be used since guidewire 34 does not pass through proximal end 38 and hub assembly 42, but rather exits the catheter shaft 36 at proximal opening 52 located substantially distal from proximal end 38. The unique catheter construction in  
30 accordance with the present invention will reduce catheter therapeutic and diagnostic procedure time since catheter device exchanges may be performed relatively more easily and quickly by a single operator. Additional personnel and time associated with maintaining the placement of a  
35 conventional (approximately 400 cm) guidewire within the targeted anatomical region is eliminated, reducing the overall costs of the procedure.

Referring to Fig. 2, a partial elevational view of a distal portion of catheter shaft 36 is shown. Shaft 36 may further include a weakened area 60. The weakened area 60 extends longitudinally along guidewire lumen 58 (not shown) between proximal opening 52 and distal end 40.

When guidewire 34 is positioned within guidewire lumen 58, weakened area 60 allows guidewire 34 to be removed from guidewire lumen 58 by "peeling away" guidewire 34 from catheter shaft 36. Weakened area 60 may include less catheter material than the remaining portion of shaft 36, or may be perforated, cut or slit.

Another embodiment of the present invention is shown generally in Fig. 3. Fig. 3 is a partial elevational view of catheter 32, which may be a "convertible" catheter design. In catheter 32, shaft 36 includes an opening 52 which is a skive port 62 for access to guidewire lumen 58. Catheter 32 is a convertible catheter design in that an existing catheter may be modified to include skive port 62. As a convertible catheter design, skive port 62 is formed by cutting an opening in shaft 36 for access to guidewire lumen 58. It is recognized that catheter 32 may be manufactured to include skive port 62.

Referring to Fig. 3A, proximal to skive port 62 catheter shaft 36 includes ancillary lumen 54 and ancillary lumen 56 as previously described herein. Additionally, shaft 36 includes guidewire lumen 58 extending between proximal end 38 and distal end 40, including between skive port 62 and proximal end 38. Referring to Fig. 3B, guidewire 34 may access guidewire lumen 58 at skive port 62 and extend through the guidewire lumen 58 emerging from distal end 40.

With this embodiment, conventional guidewire techniques may be used for positioning and exchanging catheter 32 within a patient's alimentary canal system. Further, the convertible catheter design incorporates features which allow rapid exchange of catheters by a single operator. Skive port 62 opening 52 allows catheter



32 to be used in rapid exchange of catheter 32 when an alternative catheter is necessary during a procedure. By allowing the guidewire 34 to enter the guidewire lumen 58 at a location distal from the proximal end 38, relatively shorter guidewires may be used during catheter procedures within the alimentary canal system, resulting in a more efficient and less costly procedure.

It is recognized that other means for accessing the guidewire lumen 58 at a location distal from the proximal end 38 are contemplated within the scope of the present invention. Referring to Fig. 4, a weakened location or slit 64 is shown within area A for accessing the guidewire lumen 58. Referring to Fig. 4A, proximal to the slit 64, the guidewire may be positioned adjacent the catheter shaft 36. Guidewire 34 enters guidewire lumen 58 at slit 64 for passage of guidewire 34 through the guidewire lumen 58. Referring to Fig. 4B, guidewire 34 is slidably contained within the guidewire lumen 58 at a location distal of the slit 64. With this embodiment, since guidewire lumen 58 may extend longitudinally from the proximal end 38 to the distal end 40, conventional guidewire techniques may also be used during the catheter procedure.

Referring to Fig. 5, another embodiment of the catheter of the present invention incorporating features which allow rapid exchange of catheters by a single operator is generally shown. The catheter assembly 30 includes a "port and channel" configuration. For access to guidewire lumen 34, shaft 36 includes a first opening or intermediate port 66 located proximal of the distal end 40. A second opening or proximal port 68 is located proximal of the intermediate port 66 and proximal of distal end 40. Extending between the intermediate port 66 and proximal port 68 is a longitudinal channel 70.

Guidewire lumen 34 extends longitudinally between proximal end 38 and distal end 40. Referring to Fig. 5A, channel 70 is located within the wall of catheter shaft 36, providing access to guidewire lumen 58 between proximal

port 68 and intermediate port 66. Preferably, channel 70 includes a radial opening extending between proximal port 68 and intermediate port 66. It is also recognized that channel 70 may be a weakened area within the wall of the catheter shaft, a perforated area, or a slit which extends  
5 between proximal port 68 and intermediate port 66.

In one embodiment, intermediate port 66 is located near distal end 40, and proximal port 68 is located near proximal end 38. Referring to Fig. 6, the distal end of guidewire 34 may be inserted within the intermediate port 66 (not shown), passing through guidewire lumen 58 and emerging from the catheter 32 distal end 40. Referring also to Fig. 6A, guidewire 34 may then be snapped through channel 70 into guidewire lumen 58 with the proximal end of the guidewire 34 exiting the proximal port 68. With this "port and channel" design, both conventional and rapid exchange techniques may be used.  
10  
15

Fig. 7 shows a partial elevational view of the catheter assembly 30 in accordance with the present invention including one preferred embodiment of a tool 59. Tool 59 aids in guiding guidewire 34 during a catheter procedure. Tool 59, shown positioned over catheter shaft 36, includes a body member 80 having a generally tubular shape. The body member 80 includes a proximal end 82, a distal end 84, and a lumen 86 extending longitudinally therethrough. The lumen 86 is sized for slidable receipt of catheter shaft 36.  
20  
25

Located near the proximal end 82 of tool 59 is a gripping mechanism 88. Gripping mechanism 88 aids a user in gripping tool 59 during use of tool 59. Located proximal to the distal end 84 of tool 59 is guidewire opening 90. Guidewire opening 90 is brought in communication with a desired port or opening along the catheter 36 shaft to aid in guiding a guidewire (such as guidewire 34) into guidewire lumen 58.  
30  
35

Referring to Fig. 7A, tool 59 further includes a locking mechanism 92. Referring to Fig. 7B, which is a



cross-sectional view of the tool 59 shown in Fig. 7A, locking mechanism 92 further includes a locking head 94, a stem 96 and an operating mechanism 100.

Operating mechanism 100 is located exterior of body member 80. Operating mechanism 100 is coupled to stem 96. Stem 96 extends through an opening 102 in body member 80, and is coupled to locking head 94. Locking mechanism 92 is moveable within an interior chamber 104 of body member 80.

More specifically, by applying pressure externally to operating mechanism 100, locking head 94 is moveable within interior chamber 104 for moving tool 59 between a locked and unlocked position relative to catheter shaft 36. When positioned in a locked position (as shown in Fig. 7B), tool 59 is locked onto catheter shaft 36. When in an unlocked position, tool 59 allows catheter shaft 36 to pass through lumen 86 and move freely relative to tool 59.

Referring again to Fig. 7A and Fig. 7B, tool 59 is shown in a locked position. In this position, locking head 94 friction locks the catheter shaft 36 within lumen 86. As indicated by directional arrow 106, tool 59 allows the catheter shaft 36 to be held stationary, while guidewire 34 is inserted into the guidewire lumen 58 through an opening or port in the catheter shaft 36 (such as proximal port 66 or intermediate port 68 in Fig. 7).

Referring to Fig. 7C, once guidewire 34 is in place during a biliary procedure, it may be necessary to remove the catheter shaft 36. By applying pressure to operating mechanism 100, locking mechanism 92 may be moved to an unlocked position, as shown in Fig. 7D. The guidewire 34 may be held stationary, and the catheter shaft 36 may be removed (indicated by directional arrow 108), allowing the catheter shaft 36 to be removed or "peeled away" from the guidewire 34 while the guidewire 34 remains positioned within the patient's body.

Referring to Fig. 7E, tool 59 may be used to back load catheter shaft 36 onto guidewire 34 positioned within the patient's biliary tree. Referring to Fig. 7F, to start

back loading catheter shaft 36 onto guidewire 34, tool 59 is positioned over the desired opening (such as intermediate opening 68 in the embodiment shown in Fig. 7) and locked to catheter shaft 36 in a deflected position.

5 By applying pressure to operating mechanism 100 (indicated by directional arrow 110), locking head 94 locks catheter shaft 36 in a "deflected" position. By locking the tool 59 to catheter shaft 36 in a deflected position, tool 59 aids in back loading the catheter shaft 36 onto  
10 guidewire 34.

To start back loading, the distal end 40 of catheter shaft 36 is inserted over the proximal end of guidewire 34. As catheter shaft 36 passes over the guidewire 34, the proximal end of guidewire 34 is guided through the catheter  
15 intermediate opening 66, through guidewire opening 90, exiting tool 59.

Referring to Fig. 7G, once the proximal end of guidewire 34 is guided through the intermediate opening 66, catheter shaft 36 may continue to be back loaded onto  
20 guidewire 34. Referring to Fig. 7H, by returning locking mechanism 92 to an unlocked position, guidewire 34 may be held stationary relative to tool 59, and catheter shaft 36 moves freely within lumen 86 (indicated by directional arrow 112), allowing catheter shaft 36 to be loaded onto  
25 guidewire 34. As catheter shaft 36 is loaded onto guidewire 34, the tool 59 aids in guiding guidewire 34 through channel 70 into the guidewire lumen 58 until guidewire 34 exits proximal opening 68.

Tool 59 aids in guiding guidewire 34 through opening  
30 52 (shown in Fig. 1) or "port and channel" proximal port 68, channel 70, and intermediate port 66 (as shown in Fig. 7). Tool 59 allows for gradual introduction of guidewire 34 into the guidewire lumen 58 during an endoscopic procedure. As previously described herein, it is  
35 recognized that tool 59 may be used to hold catheter shaft 36 stationary while guidewire 34 is being advanced or retracted during a catheter procedure. Alternatively, it



is recognized that tool 59 may be used to hold guidewire 34 in place during a rapid exchange procedure or during advancement or retraction of catheter shaft 36 over guidewire 34.

5 It is also recognized that a locking device (not shown) may be located proximate first port 66 or proximate second port 68 to aid in guiding guidewire 34 into guidewire lumen 58 during an endoscopic procedure. The locking device can be similar to the tool 59 as previously  
10 described herein. Additionally, it is recognized that tool 59 may be used to hold the catheter shaft 36 in place while guidewire 34 is being advanced or retracted during a catheter procedure. Alternatively, it is recognized that tool 59 may be used to hold guidewire 34 in place during a  
15 rapid exchange procedure, or during advancement or retraction of catheter shaft 36 over guidewire 34.

It is recognized that the rapid exchange technology of the present invention may be utilized in different types of catheter assemblies used within the alimentary canal.  
20 Referring to Fig. 8, catheter assembly 30 is used as a rapid exchange retrieval balloon system used for stone retrieval or isolated visualization techniques. Ancillary lumens 54 and 56 (Fig. 1A) are available for passage of retrieval balloon catheter 72 having a balloon 74 located  
25 at its distal end, and for passage of dye injection apparatus 76. With this embodiment, the guidewire lumen may be accessed using conventional guidewire techniques through the proximal end of catheter 32 or using rapid exchange techniques.

30 Referring to Fig. 9, the rapid exchange designs of the present invention may be used for other alimentary canal catheter applications, such as a rapid exchange sphincter catheter used for endoscopic retrograde sphincterotomy, shown using a cutting wire apparatus 78. Again, the  
35 guidewire lumen (not shown) may be accessed by conventional guidewire techniques at the proximal end, or alternatively, using the rapid exchange technology of the present

invention.

5 The rapid exchange catheter of the present invention is a multi-lumen catheter. With this invention, the guidewire lumen is isolated from the ancillary lumens allowing for exceptional contrast flow for high quality opacification without the need for guidewire removal. Treatment and therapeutic devices, such as retrieval balloon catheters or catheters having cutting apparatus may be advanced through the ancillary lumens, without  
10 interference of a guidewire located within the guidewire lumen. Additionally, isolation of the guidewire lumen from the contrast lumen minimizes the risk of bubble formation during contrast flow and produces a contrast-free guidewire surface for efficient device exchanges.

15 The rapid exchange biliary catheter of the present invention results in less time consuming and less costly catheter procedures, since a much shorter guidewire may be used and additional personnel are not required to maintain the guidewire position during a catheter procedure. In use  
20 in a typical endoscopic procedure, an endoscope is first introduced into the mouth of a patient and is guided through the patient's alimentary canal. Specifically, the endoscope is guided down the esophagus, through the stomach, past the pyloric sphincter of the stomach and into  
25 the duodenum. The endoscope has a lumen extending longitudinally between its proximal end and the distal end.

The endoscope is guided through the alimentary canal until the distal end of the endoscope is proximate the target area within the anatomy to receive treatment. In an  
30 endoscopic biliary procedure, the endoscope is guided into the duodenum until the opening at the distal end of the endoscope is proximate the papilla of vater. The papilla of vater is located between the sphincter of oddi, which leads to the common bile duct, hepatic, and pancreatic  
35 ducts. The proximate end of the endoscope extends and remains outside the mouth of the patient.

With general reference to the various embodiments



shown in Figs. 1-7, once the endoscope is in proper position, guidewire 34 is inserted into the proximal opening of the endoscope and advanced through the lumen of the endoscope until guidewire 34 distal end emerges from the opening at the distal end of the endoscope. The distal tip of guidewire 34 may be guided through the orifice leading to the papilla of vater for access into the biliary tree.

Once the distal end of guidewire 34 is positioned within the biliary tree (including the common bile, hepatic or pancreatic ducts), rapid exchange catheter 32, in accordance with the present invention, may be back-loaded onto guidewire 34. Distal end 40 of catheter 32 is loaded onto the proximal end of guidewire 34. Rapid exchange catheter 32 is advanced over guidewire 34, until the distal end 40 exits the distal end of the endoscope. Within the endoscope, distal from opening 52, the guidewire passes through guidewire lumen 58, and proximal to opening 52, the guidewire is positioned adjacent catheter shaft 36.

Distal end 40 of catheter 32 tracks guidewire 34 through the orifice leading to the papilla of vater, and into the desired duct, such as the common bile duct. Once distal end 40 of catheter 32 is in position in the common bile duct, catheter procedures may be performed, such as injecting a contrast media, such as radiopaque dye, through ancillary lumen 54 and ancillary lumen 56 into the common bile duct for visualization of the duct.

Since the proximal end of guidewire 34 exits the guidewire lumen 58 at a location distal of the catheter 32 proximal end 38, shorter guidewires may be used by the physician as previously described herein. In one embodiment, a 250 cm guidewire is used. The use of the shorter guidewire eliminates many disadvantages of using longer guidewires which were approximately 400 cm in length, while maintaining or improving the efficiency and outcome of the procedure.

Alternatively, if a guidewire 34 has not been

previously positioned within the biliary tree, rapid exchange catheter 32 may be used to establish access to the targeted anatomy location within the alimentary canal. Catheter 32 is passed through the lumen of the endoscope, until distal end 40 is guided up through the orifice into the papilla of vater, and into the desired duct, such as the common bile duct. The guidewire 34 is then inserted into the endoscope lumen adjacent catheter 32. Guidewire 34 is advanced through opening 52 into guidewire lumen 58 to the targeted area, such as the common bile duct.

Once guidewire 34 is in position, and the desired catheter procedure has been completed, rapid exchange catheter 32 can be exchanged or removed from the endoscope, while leaving guidewire 34 in position for other catheter procedures. Catheter 32 is removed from guidewire 34 by tracking catheter 32 back over guidewire 34 until guidewire lumen 58 is retracted completely off the proximal end of guidewire 34.

Referring to the embodiment of Fig. 2, if catheter 32 includes weakened area 60, once opening 52 is outside of the proximal end of the endoscope, catheter 52 may be "peeled away" from guidewire 34 until catheter 32 is completely removed from guidewire 34.

Although catheter 32 is removed from guidewire 34, the position of guidewire 34 is maintained within the targeted anatomy. Other rapid exchange procedures may be performed, such as the catheter assembly 30 of Fig. 8 or Fig. 9 without having to re-establish a path to the target area of the anatomy to receive therapeutic or diagnostic treatment. These catheter assemblies may be loaded onto guidewire 34 using the same rapid exchange procedures as previously described herein.

If a convertible catheter (as shown in Fig. 3) or "slit" catheter (as shown in Fig. 4) are used, the physician may alternate between conventional and rapid exchange guidewire procedures since guidewire lumen 58 within these devices extend from distal end 40 to proximal



end 38.

If catheter 32 further includes a "port and channel" type configuration (Fig. 5), as rapid exchange catheter 32 is back-loaded onto guidewire 34, the proximal end of guidewire 34 exits the distal or first port 66 of the catheter 32. As catheter 32 is advanced over guidewire 34, the guidewire is "snapped" into guidewire lumen 58 via channel 70. When catheter 32 is fully advanced over guidewire 34, guidewire 34 exits guidewire lumen 58 through proximal or second port 68.

With the "port and channel" technology, when catheter 32 is positioned within the endoscope, guidewire 34 is not located adjacent catheter shaft 36, but rather is positioned within guidewire lumen 58. Guidewire 34 exits guidewire lumen 58 at second port 68, which is located outside of and proximal to the proximal end of the endoscope. With this configuration, additional working space is not required for guidewire 34 to lie adjacent catheter 32 within the endoscope lumen. This configuration allows for more room within the working space of the endoscope, allowing for larger ancillary lumens within catheter 32 itself.

The "port and channel" catheter configuration may be manufactured as a catheter unit, or, alternatively, existing catheter devices may be converted or modified to include the "port and channel" design. Upon retraction of catheter 32 from the endoscope, guidewire 34 is peeled away from the endoscope via channel 70 until first port 66 is retracted from the proximal end of the endoscope. The short length of catheter 32 distal of first port 66, which does not include access channel 70, is retracted completely off the proximal end of guidewire 34.

As previously described herein, if guidewire 34 is not in position within the targeted anatomical location, the rapid exchange catheter 32 may be used to cannulate the path to the targeted location within the patient's anatomy, such as cannulating the papilla of vater for access to the

ducts of the biliary tree. As previously described herein, the catheter may then be removed, and other rapid exchange devices using the technology of the present invention may be exchanged over the guidewire since the guidewire remains in position within the biliary tree.

As previously described herein, guidewire lumen 58 may be a tubular member which is extruded integral the catheter 32 shaft, or alternatively, guidewire lumen 58 may be a separate tubular member which is coupled to catheter shaft 36. Although in one preferred embodiment guidewire lumen 58 is a tubular member which is located proximate distal end 40 of the catheter shaft 36, it is recognized that guidewire lumen 58 may be formed anywhere along shaft 36, may be an extension of shaft 36 coupled to the distal end 40, or guidewire lumen 58 may run the entire length of shaft 36.

It will be understood, that this disclosure is, in many respects, only illustrative. Changes may be made in details, particularly in matters of shape, size, material, and arrangement of parts without exceeding the scope of the invention. Accordingly, the scope of the invention is as defined within the language of the appended claims.



## WHAT IS CLAIMED IS:

1. In a catheter for use in biliary procedures including a shaft having a proximal end and a distal end, the improvement comprising:

5 a guidewire lumen carried by the shaft extending from a location proximal the distal end of the shaft to a location proximate the distal end of the shaft; and

means for accessing the guidewire lumen from a location exterior to the catheter shaft, located distal the proximal end of the shaft said means including  
10 a first opening through the wall of the catheter shaft into the guidewire lumen located proximal the distal end of the shaft, a second opening through the wall of the shaft located proximal the first opening and a channel which gives access to the guidewire lumen extending longitudinally between the first opening and the second opening, said channel extending over a substantial portion of the  
15 length of said catheter shaft.

2. The catheter of claim 1 wherein the guidewire lumen is formed integral the shaft.

20 3. The catheter of claim 1, further comprising a tool for guiding a guidewire into the opening.

4. The catheter of claim 1, wherein the channel includes an opening extending longitudinally between the first opening and the second opening in  
25 communication with the guidewire lumen.

5. A biliary catheter for use in combination with an endoscope and a guide wire in a biliary procedure for accessing the biliary tree, the catheter comprising:

an elongate shaft having a proximal end and a distal end and a length sufficient to extend through the endoscope to reach the biliary tree;

5 a guide wire lumen extending through the shaft from a proximal port near the proximal end of the shaft to a distal port near the distal end of the shaft;

a channel for accessing the guide wire lumen disposed proximal of the distal end of the shaft; and

means for limiting access to the guide wire lumen through the channel.

10 6. The biliary catheter of claim 5, wherein the access limiting means comprises a weakness within a wall of the shaft.

7. The biliary catheter of claim 5, wherein the access limiting means comprises a perforated area within a wall of the shaft.

15

8. The biliary catheter of claim 5, wherein the access limiting means comprises a slit having a width less than a diameter of the guide wire.

9. The biliary catheter of claim 5, wherein the channel for accessing  
20 the guide wire lumen includes a proximal end and a distal end, the catheter further comprising a first opening through a wall of the shaft into the guide wire lumen positioned at the distal end of the channel.

10. The biliary catheter of claim 9, further comprising a second  
25 opening through the wall of the shaft into the guide wire lumen positioned at the proximal end of the channel.

11. The biliary catheter of claim 10, further comprising a tool for guiding the guide wire into the second opening.



12. The biliary catheter of claim 5, wherein the guide wire lumen is formed integral with the shaft.

5 13. The biliary catheter of claim 5, further comprising a first ancillary lumen extending through the shaft from the proximal end to the distal end thereof.

10 14. The biliary catheter of claim 13, further comprising a second ancillary lumen extending through the shaft from the proximal end to the distal end thereof.

15 15. An endoscopic catheter for use in combination with an endoscope and a guide wire in an endoscopic procedure for accessing a duct via the papilla of vater, the endoscopic catheter comprising:

an elongate shaft having a proximal end, a distal end and a length sufficient to extend through the endoscope and into the duct;

a guide wire lumen extending through the shaft from a proximal port to a distal port;

20 a channel for accessing the guide wire lumen to facilitate single operator exchange; and

a means for limiting access to the guide wire lumen through the channel.

25 16. The endoscopic catheter of claim 15, wherein the access limiting means comprises a weakness within a wall of the shaft.

17. The endoscopic catheter of claim 15, wherein the access limiting means comprises a perforated area within a wall of the shaft.

18. The endoscopic catheter of claim 15, wherein the access limiting

means comprises a slit having a width less than a diameter of the guide wire.

19. The endoscopic catheter of claim 15, wherein the channel for accessing the guide wire lumen includes a proximal end, and a distal end, the  
5 catheter further comprising a first opening through a wall of the shaft into the guide wire lumen positioned at the distal end of the channel.

20. The endoscopic catheter of claim 19, further comprising a second opening through the wall of the shaft into the guide wire lumen positioned at  
10 the proximal end of the channel.

21. The endoscopic catheter of claim 20, further comprising a tool for guiding the guide wire into the second opening.

15 22. The endoscopic catheter of claim 15, wherein the guide wire lumen is formed integral with the shaft.

23. The endoscopic catheter of claim 15, further comprising a first ancillary lumen extending through the shaft from the proximal end to the distal  
20 end thereof.

24. The endoscopic catheter of claim 23, further comprising a second ancillary lumen extending through the shaft from the proximal end to the distal  
end thereof.

25





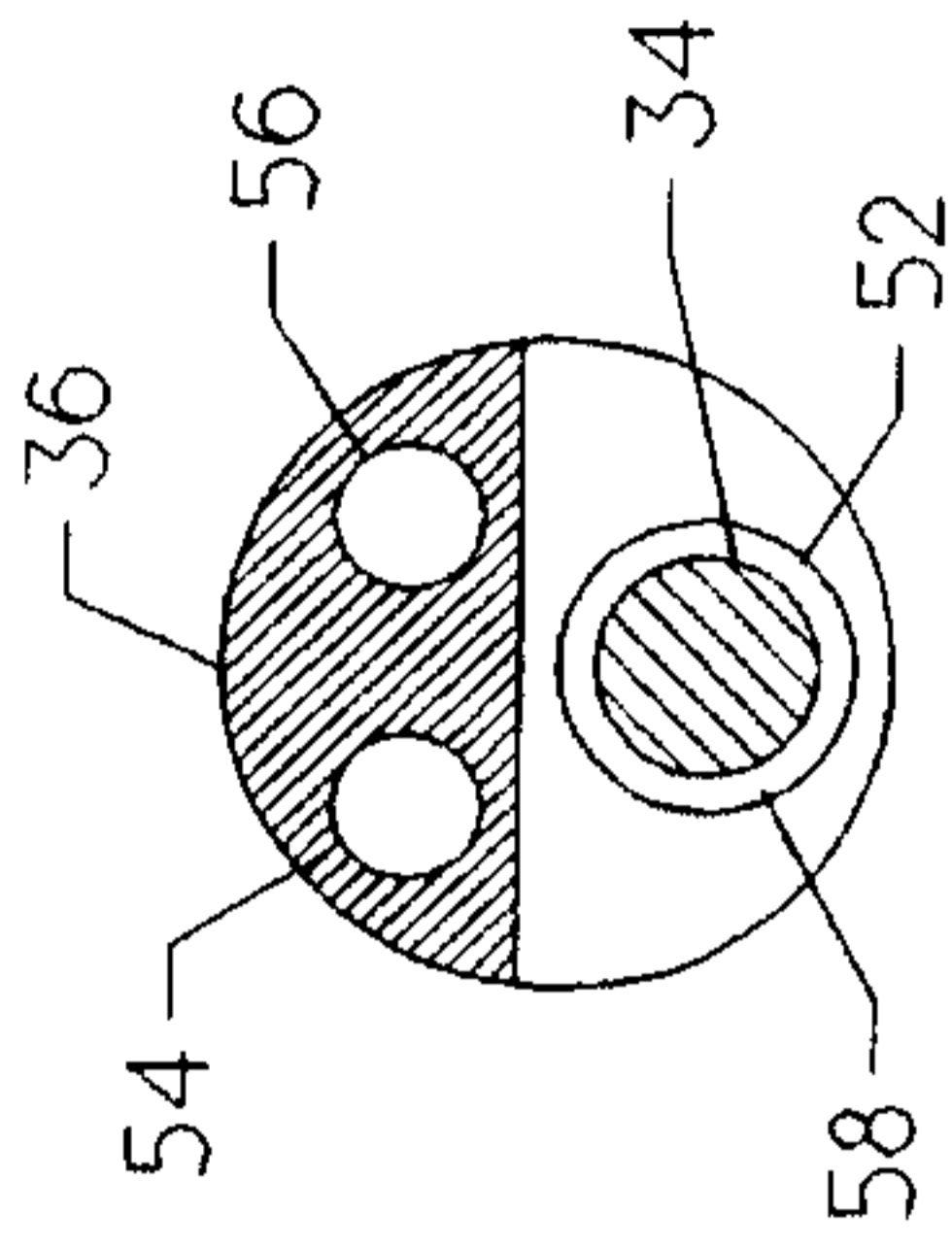

FIG. 1B

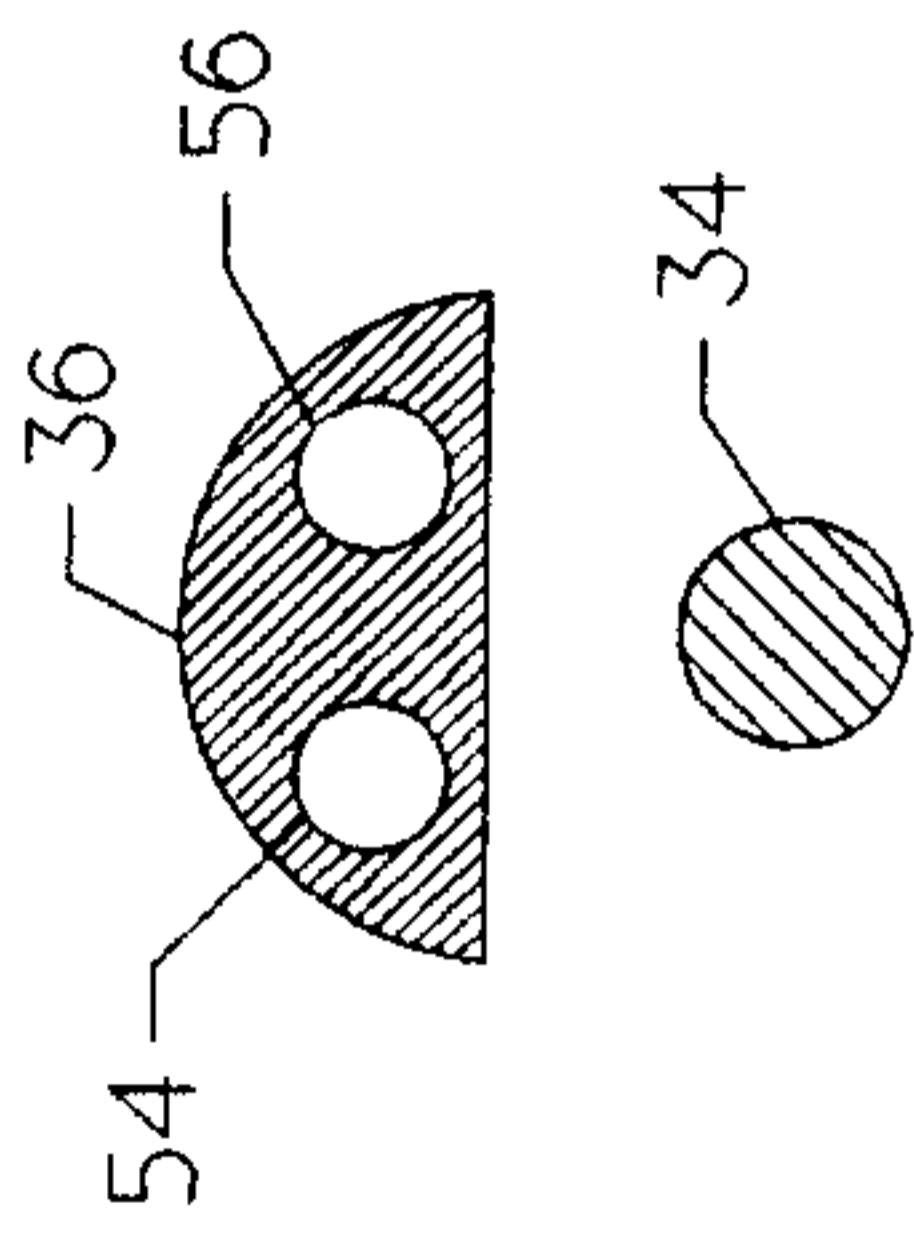

FIG. 1A

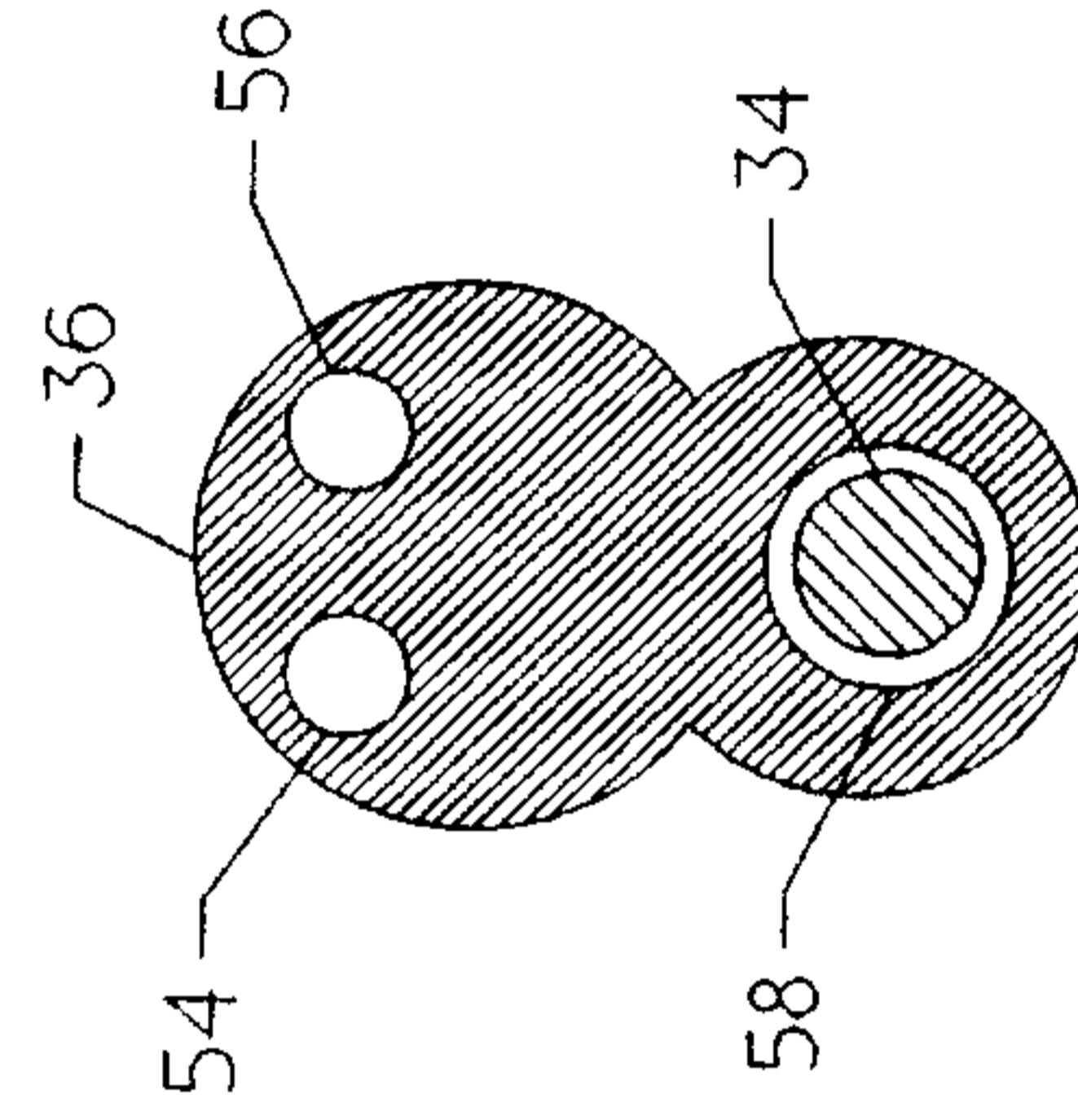

FIG. 1D

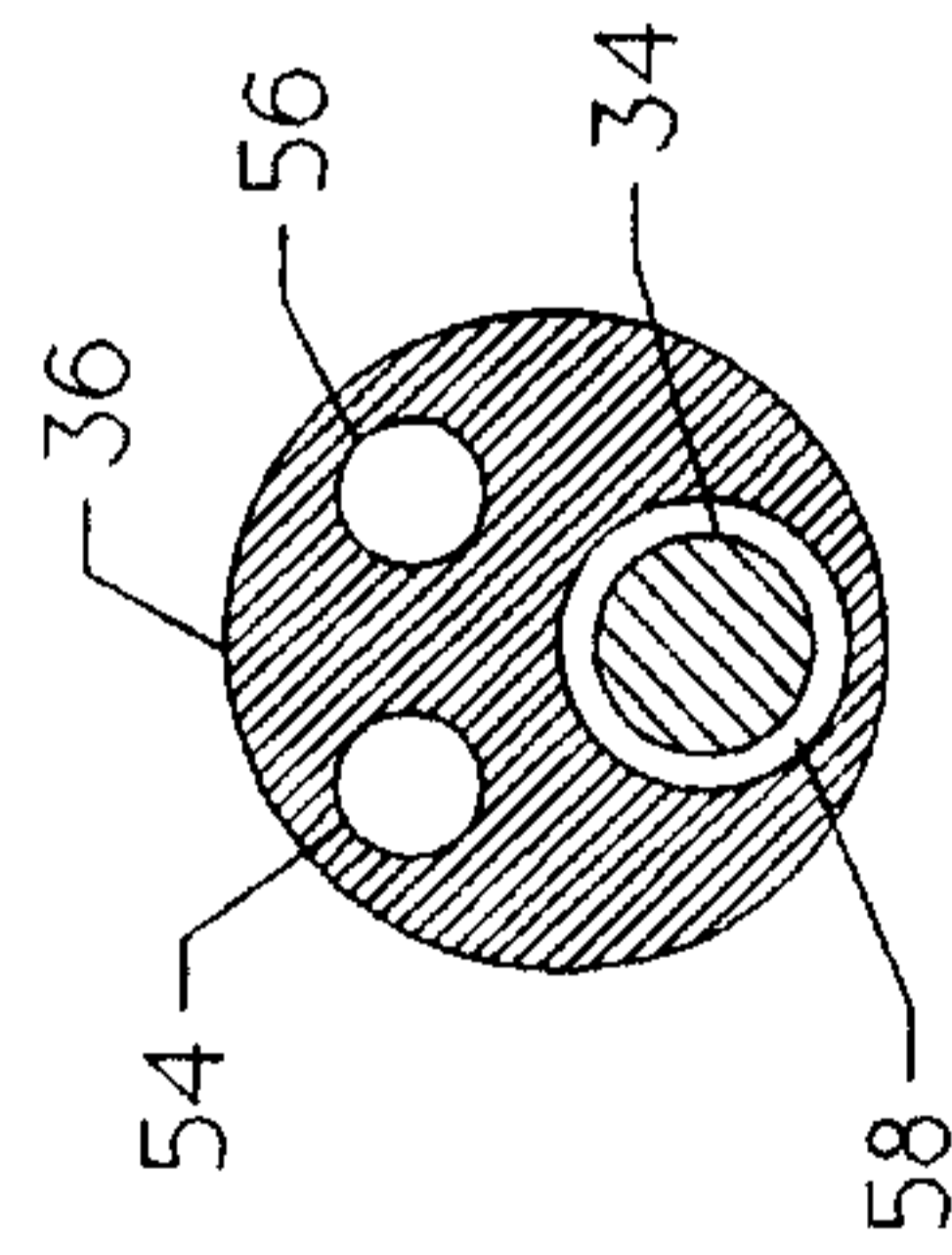

FIG. 1C



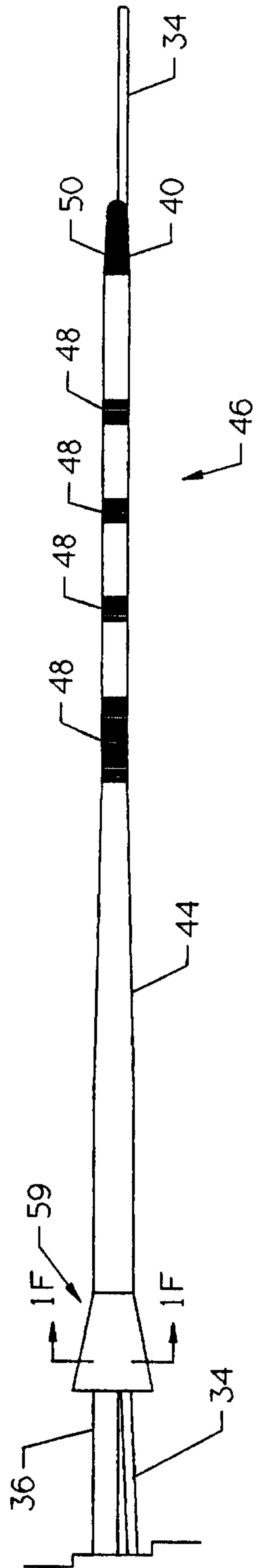

FIG. 1E

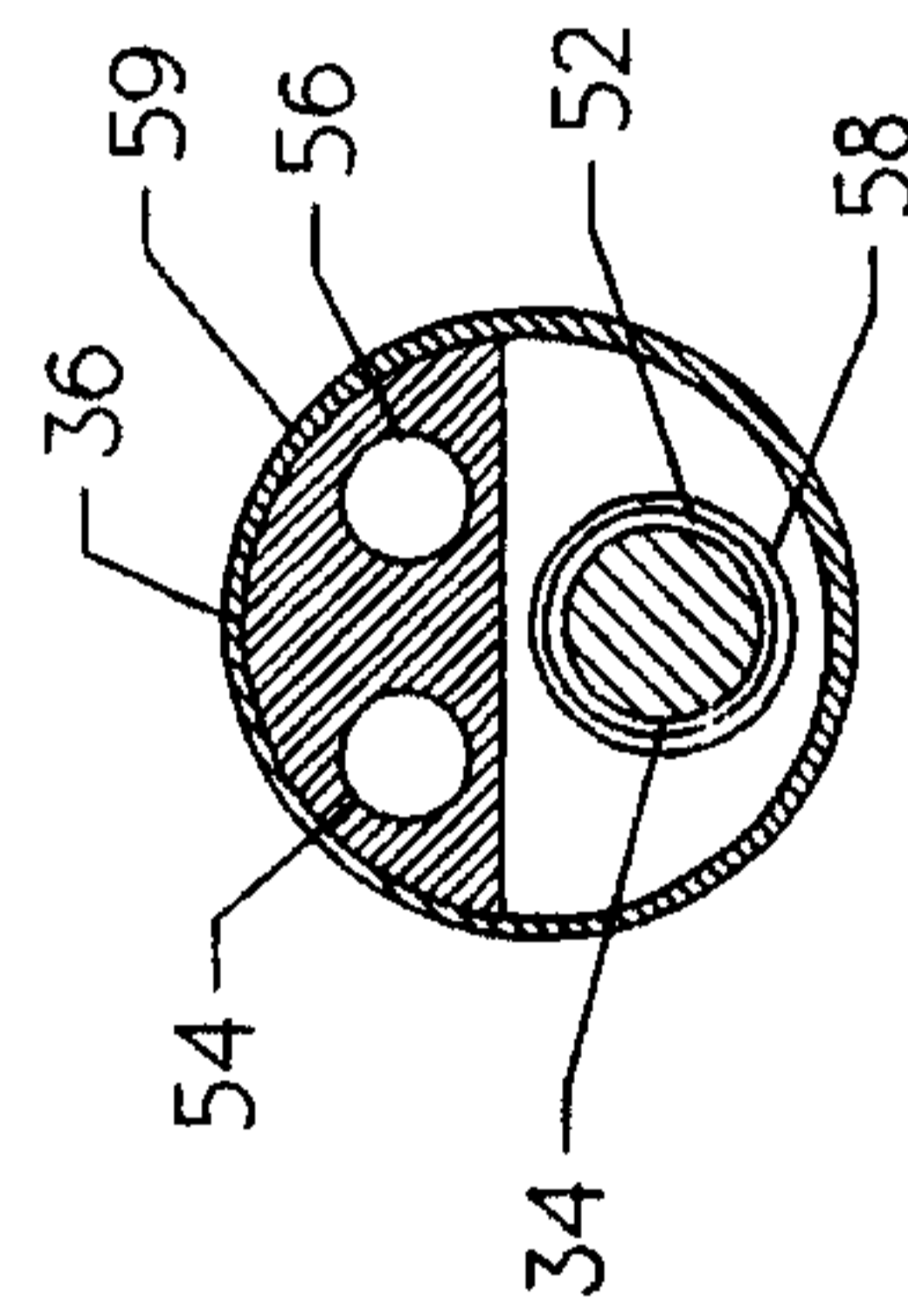

FIG. 1F

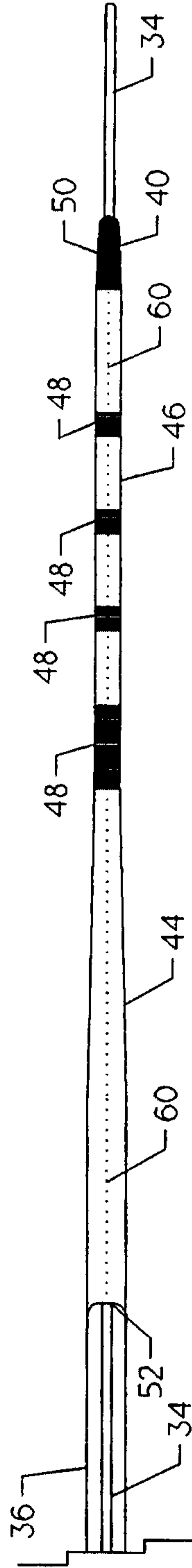

FIG. 2



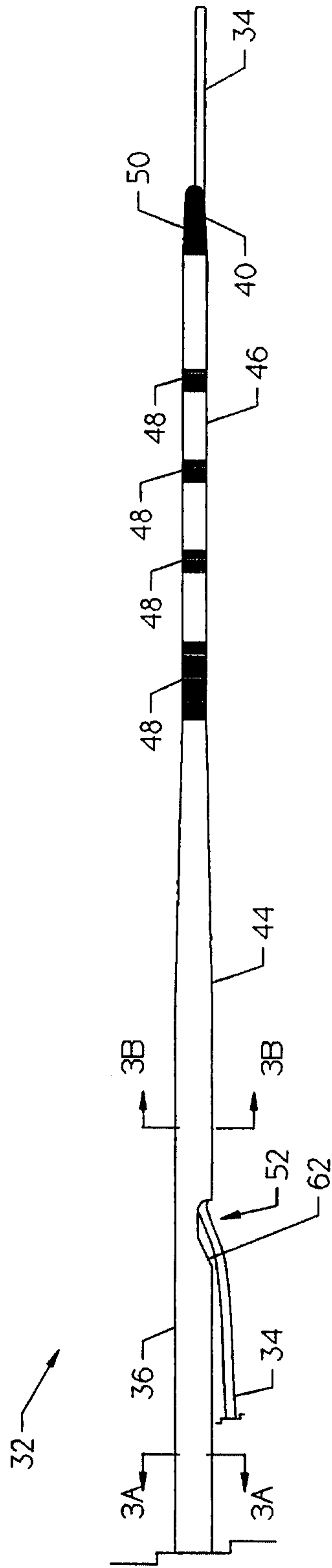

FIG. 3

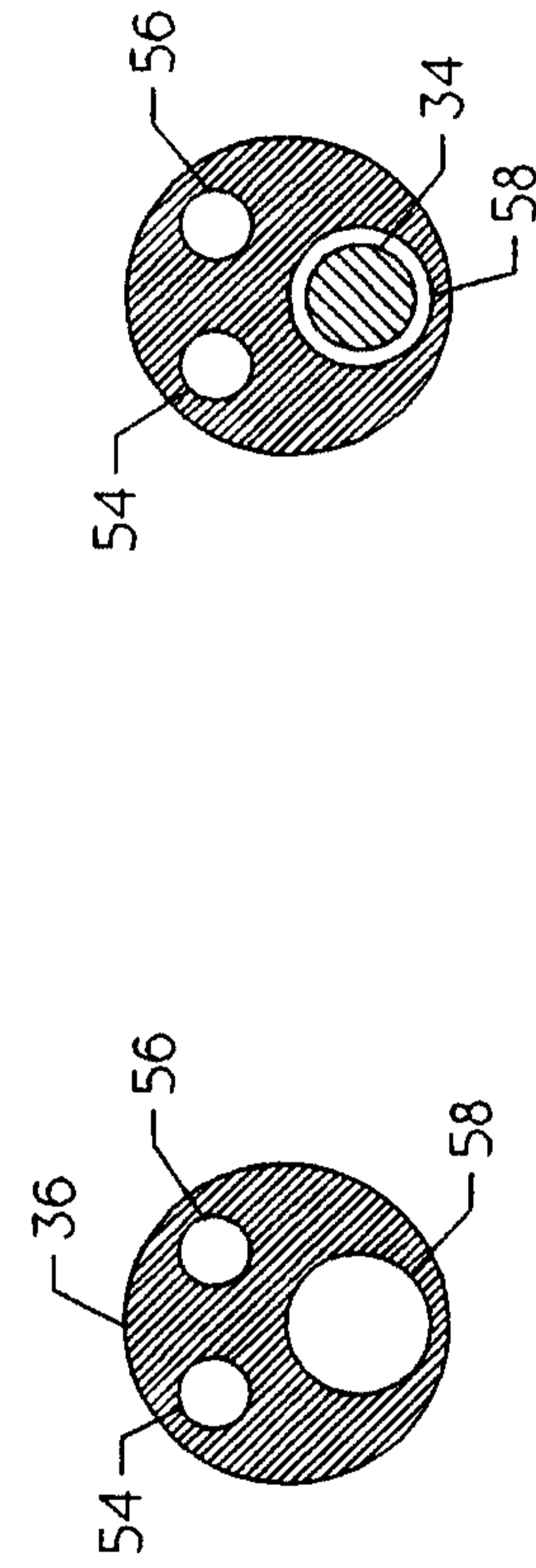

FIG. 3A FIG. 3B

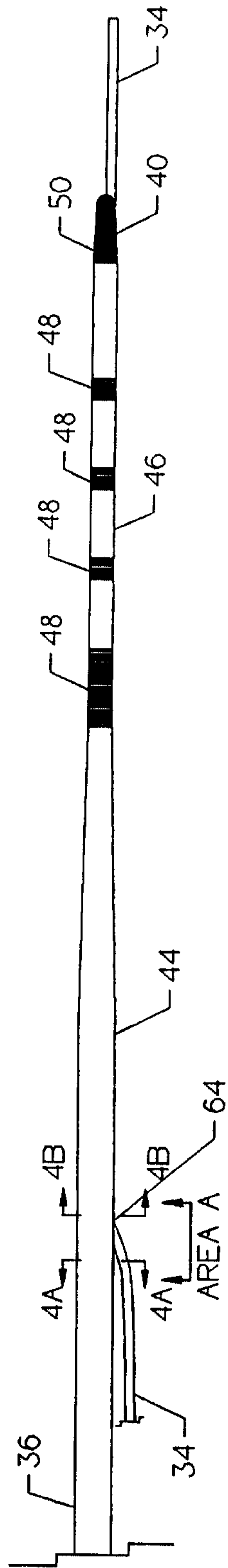

FIG. 4



FIG. 4A FIG. 4B



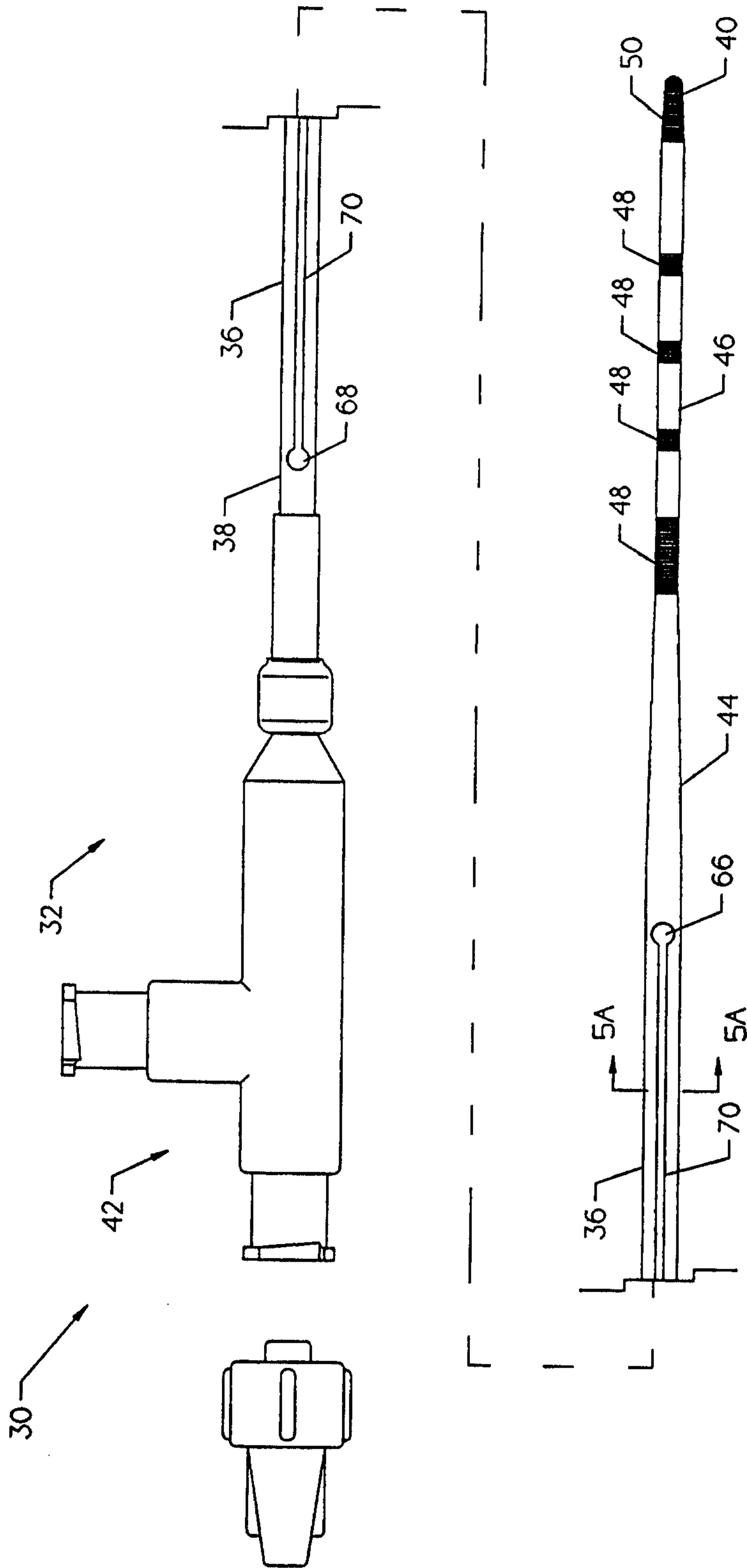

FIG. 5

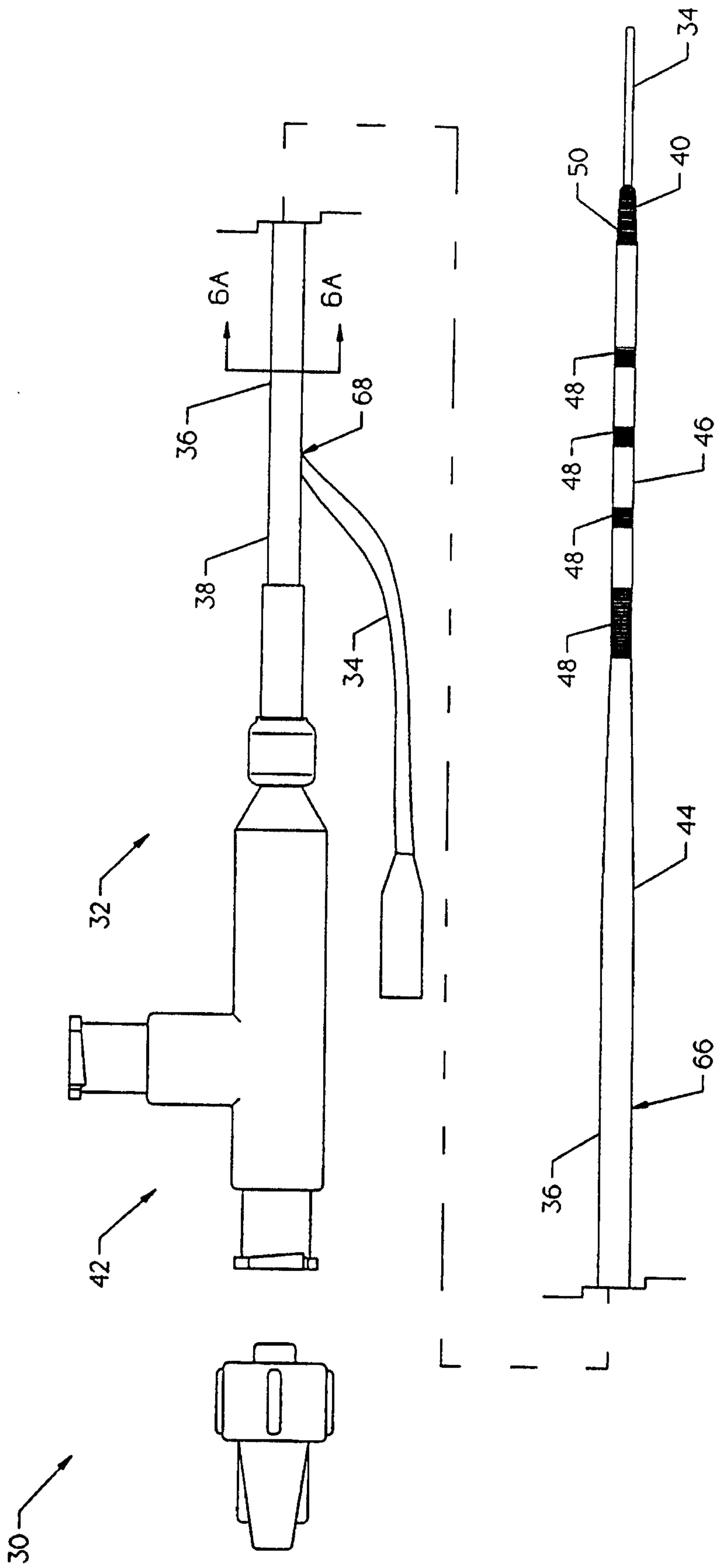

FIG. 6



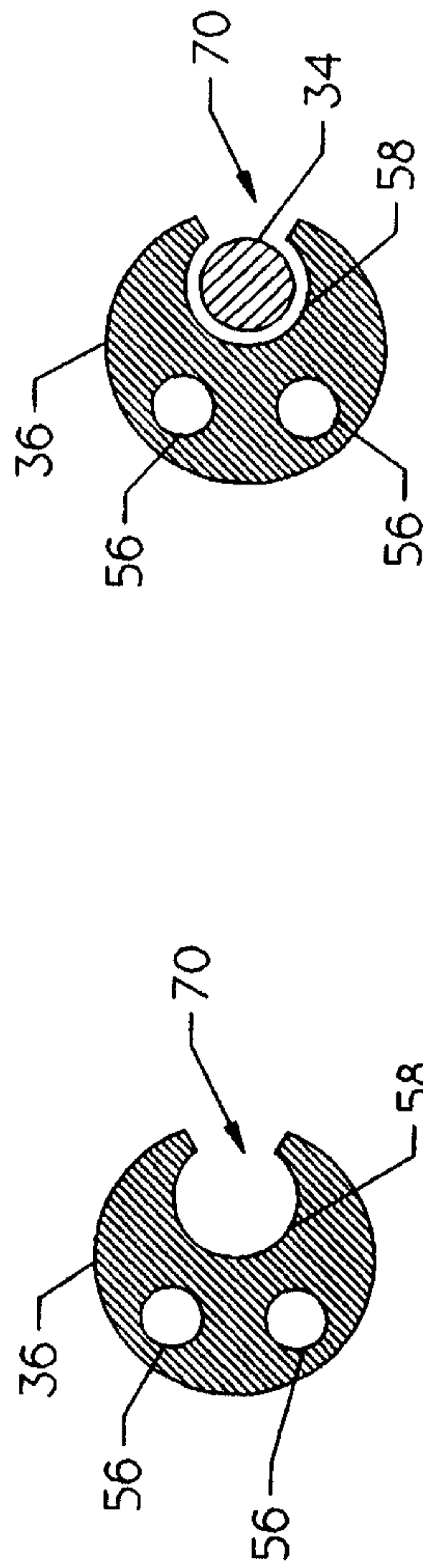

FIG. 5A FIG. 6A





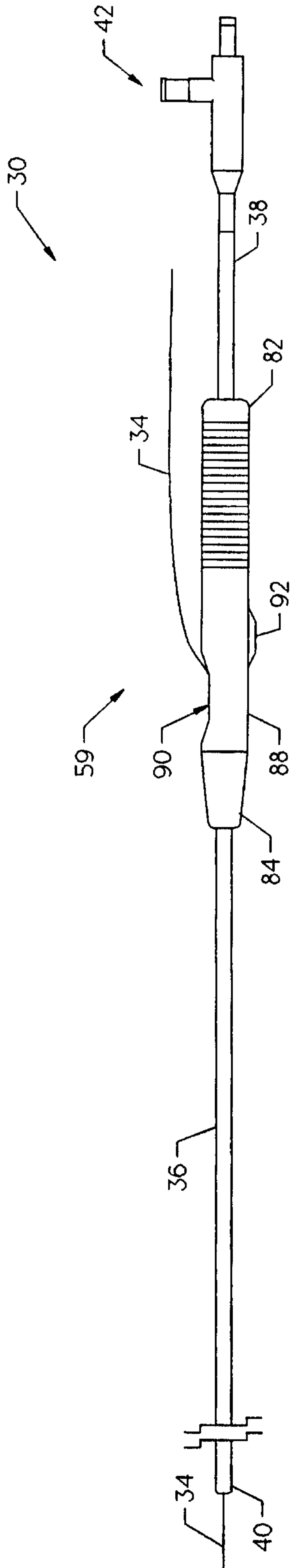

FIG. 7A

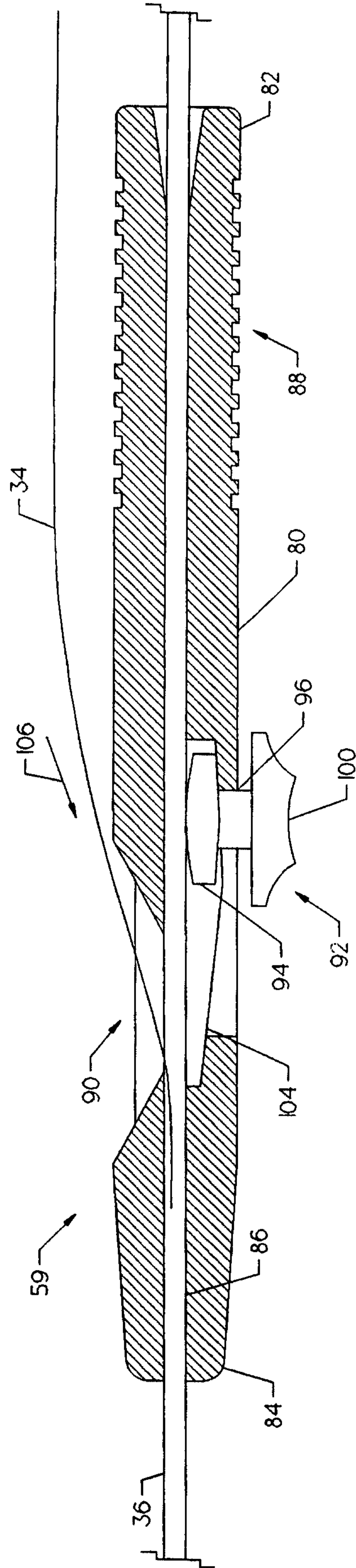

FIG. 7B

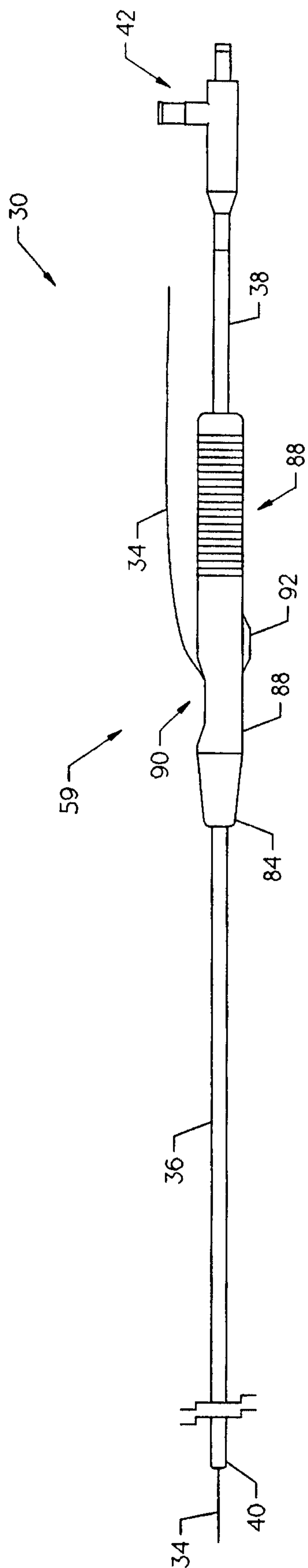

FIG. 7C

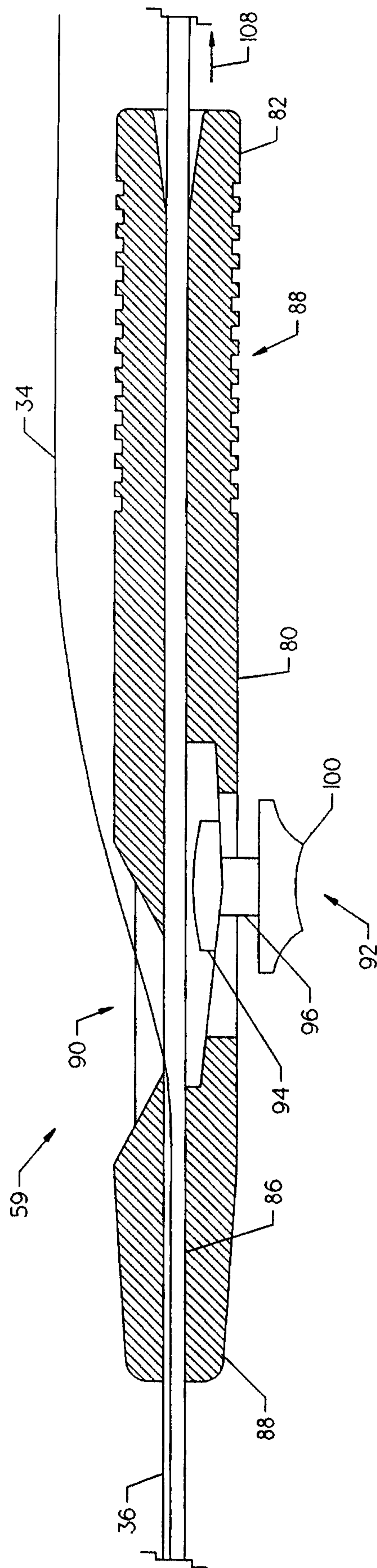

FIG. 7D



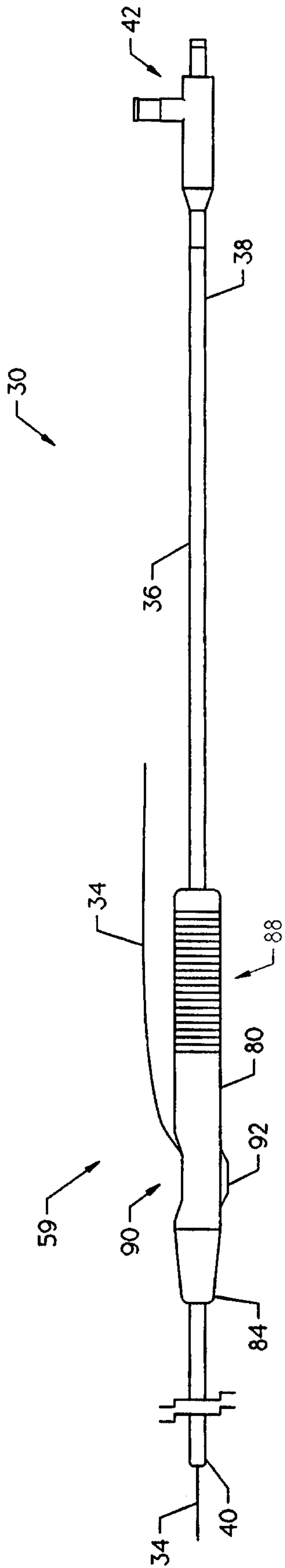

FIG. 7E

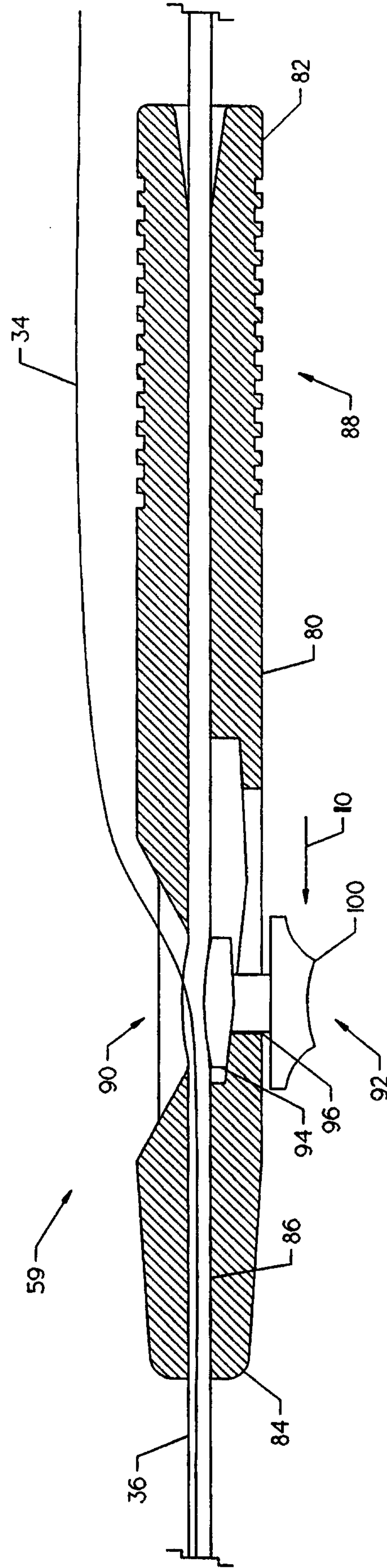

FIG. 7F

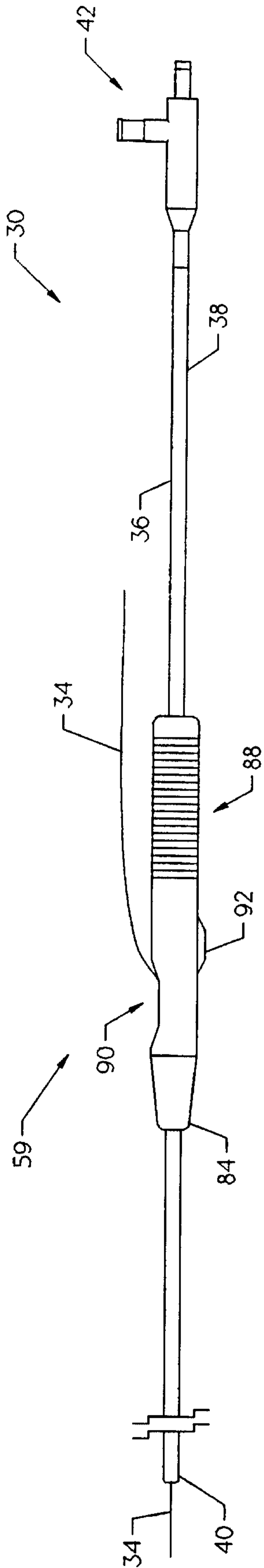

FIG. 7G

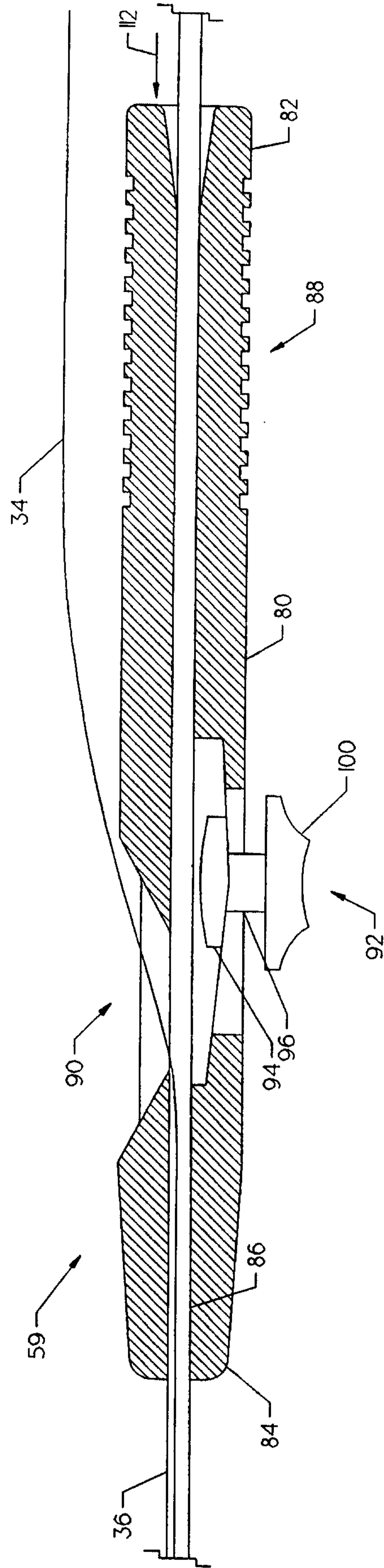

FIG. 7H

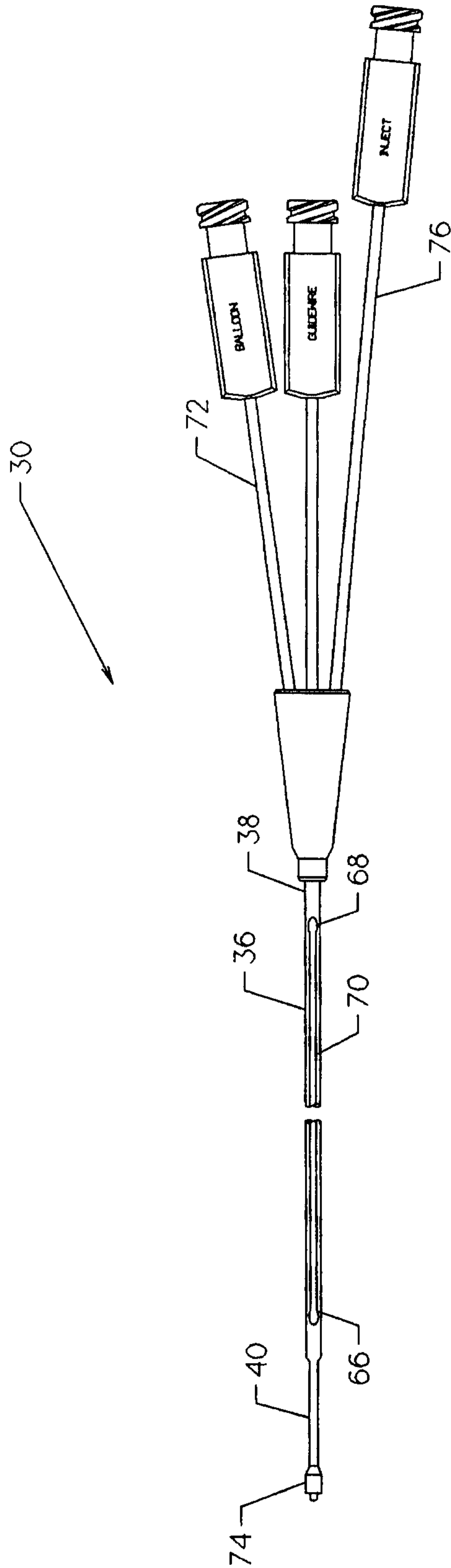

FIG. 8



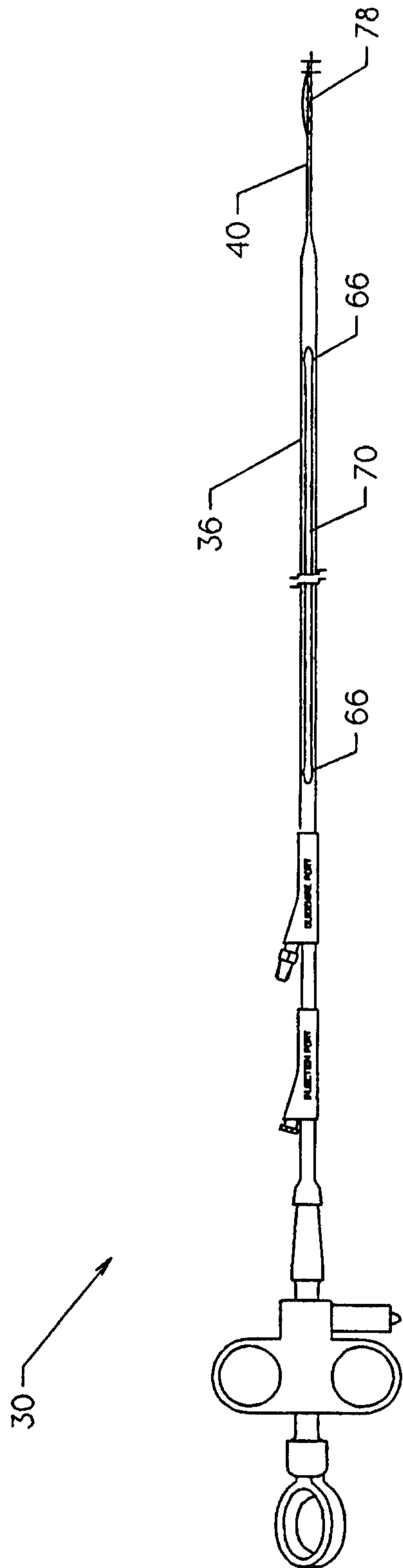

FIG. 9

