



Europäisches Patentamt
European Patent Office
Office européen des brevets



(11) **EP 1 099 564 A1**

(12) **EUROPEAN PATENT APPLICATION**

(43) Date of publication:
16.05.2001 Bulletin 2001/20

(51) Int Cl.7: **B41M 5/20, B41M 3/00,
G09F 13/22**

(21) Application number: **99500207.8**

(22) Date of filing: **10.11.1999**

(84) Designated Contracting States:
**AT BE CH CY DE DK ES FI FR GB GR IE IT LI LU
MC NL PT SE**
Designated Extension States:
AL LT LV MK RO SI

(72) Inventor: **Procupetz, Gabriel
Escalera B, 6 1a 08034 Barcelona (ES)**

(74) Representative: **Aguilar Forment, Domènec
c/o Aguilar & Revenga
C. Consell de Cent 415, 5.o-1.a
08009 Barcelona (ES)**

(71) Applicant: **Oriel Tecnológicas, S.A.
08630 Abrera, Barcelona (ES)**

(54) **Emblem with luminous motifs**

(57) The emblem comprises a supporting component (1) and a laminar body (2) formed by a sheet (3) of transparent material with printed motifs (31) and with reserves (32) on the areas corresponding to the luminous motifs, a layer (4) of transparent conductive ink, a layer (5) of electroluminescent phosphor which lights up when receiving an electric current an initial layer (6) of silver-based conductive ink, a layer (7) of dielectric polymer, a second layer (8) of silver-based conductive ink, a layer (9) of nonconducting ink and a base layer (10) of white paint. The representative motifs (31) of the emblem are printed on said base layer. The layers (6,8) are equipped with feed tracks (61, 81) for connection to a power source, being the layers (4, 8) connected to each other.

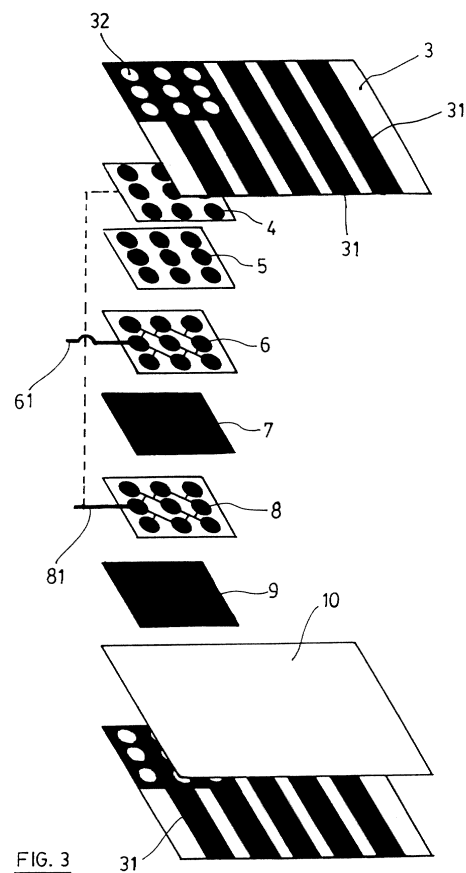

EP 1 099 564 A1

Description

OBJECT OF THE INVENTION

[0001] This invention refers to an emblem such as a flag, coat of arms or similar figure formed by a thin laminar body which includes luminous motifs on part or the entire surface of this sheet. It may be complemented by a mast type supporting component, a wire for hanging or means of gluing or adhering it on a surface.

BACKGROUND OF THE INVENTION

[0002] Emblems such as flags, coats of arms or similar figures are usually printed on a flexible laminar component, which is often a piece of cloth. They are only visible when located in lighted areas. If one would like such an emblem to be visible in the dark, light emitted by an external lighting source must be projected on the emblem. This involves significant energy consumption.

DESCRIPTION OF THE INVENTION

[0003] The emblem with luminous motifs, object of this invention, is formed by a thin sheet that displays a series of specific qualities as regards construction that allow lighting of all or part of its surface with minimum energy consumption.

[0004] For such purposes, the different motifs of the emblem are printed with chemical ink which lights up when electric power is supplied.

[0005] In accordance with the invention, the emblem has a laminar body formed by a thin sheet of transparent material, with a thickness of approximately 0.15 mm. The representative motifs of the emblem involved are printed on this sheet, with reserves in those areas set aside for the luminous motifs, a layer of transparent conductive ink, a layer of electroluminescent phosphor applied on the areas or motifs to be lighted, an initial layer of silver-based conductive ink, a layer of dielectric polymer, a second layer of silver-based conductive ink, a layer of nonconducting ink and a base layer of white paint where the representative motifs of the emblem are printed.

[0006] On an optional basis, the laminar body may be associated with a mast type support or equipped with a wire for hanging or other means which allow it to be secured or glued on a surface.

[0007] Those motifs or areas of the emblem which will not be lighted are printed on the sheet of transparent material with conventional ink, leaving the aforementioned reserves in those areas of the emblem set aside for the luminous motifs.

[0008] The layer of electroluminescent phosphor is placed between the layer of transparent conductive ink and the first layer of silver-based conductive ink so that when low-amperage current is supplied to the layer of electroluminescent phosphor, this will light up and will

be visible through the reserves defined in the sheet of transparent material.

[0009] The layer of transparent conductive ink is applied on the areas set aside for the luminous motifs, in the same areas as the reserves indicated by the printing on the transparent sheet. The layer of transparent conductive ink is applied between the reserves on the sheet of transparent material and the layer of electroluminescent phosphor in order to ensure the visibility of the light given off by the latter when a low-amperage electric current is supplied.

[0010] The layer of transparent conductive ink is electrically connected to a second layer of silver-based conductive ink.

[0011] The two layers of silver-based conductive ink are each equipped with feed tracks so that they can be connected, by the appropriate switch, either to batteries or to a low-amperage power source. Provisions may be made for the latter in the mast, for example, or by including a cable or connector which can be connected to an external power source.

[0012] The layer of electric polymer placed between the two layers of silver-based conductive ink is meant to prevent contact between these layers and, therefore, the short-circuiting of the power source.

[0013] As mentioned previously, a base layer of white paint and a layer of nonconducting ink are applied on the second silver-based conductive layer. The representative motifs of the emblem are printed on the back surface of the aforementioned. These layers aim to ensure that the user does not involuntarily come into contact with the second layer of conductive ink. They also allow viewing of the representative motifs of the emblem printed on the back side of the sheet. Of course, this does not refer to the luminous areas, since these are only visible from the front of the emblem through the reserves or non-printed areas of the sheet of transparent material.

DESCRIPTION OF THE DRAWINGS

[0014] To complement this description and facilitate understanding of the characteristics of the invention, a set of drawings are attached to this description. These drawings, which have been provided as a non-exhaustive illustration, represent the following:

- Figure 1 shows an elevation view of an example of construction of the emblem with luminous motifs. This example represents a flag with a mast equipped with batteries as a power source.
- Figure 2 shows a variant of construction of the emblem represented in Figure 1. In this case, the mast is equipped with an electric cable for connection to an external power source.
- Figure 3 shows a perspective view of the different

layers which form the laminar body of the examples in the previous figures.

PREFERRED EMBODIMENT OF THE INVENTION

[0015] As can be observed in the example of construction shown in the figures, the emblem with luminous motifs, object of the invention, is represented by a laminar body -2- associated with a mast type supporting component -1-.

[0016] This laminar body -2- is formed by a transparent PVC sheet, with an approximate thickness of 0.15 mm. The representative motifs -31- of the emblem involved are printed on the aforementioned sheet. The areas or reserves -32- where the luminous motifs are located are not printed.

[0017] The following are applied on the back side of the transparent sheet -3-: a layer -4- of transparent conductive ink, a layer -5- of electroluminescent phosphor located on the areas or motifs to be lighted, an initial layer -6- of silver-based conductive ink, a layer -7- of dielectric polymer, a second layer -8- of silver-based conductive ink, a layer -9- of nonconducting ink and a base layer -10- of white paint. The representative motifs -31- of the emblem are printed on the back surface of the aforementioned. The layers -6-, -8- of silver-based conductive ink are each equipped with feed tracks -61-, -81- for connection to a switch -12- which controls the supply from a low-amperage power source that can be switched on or off.

[0018] On an optional basis, this power source may be formed by some batteries included in the supporting component -1- or may be external. In the latter case, the supporting component -1- must be equipped with a cable -11- which, through the appropriate transformer -13-, connects the emblem with luminous motifs to the electric current or to any other type of electrical generator.

[0019] With this configuration, when the switch -12- is activated and allows input of power to the emblem, the layer -5- of electroluminescent phosphor is lit and is visible through the areas on the sheet -3- where the motifs -31- have not been printed. Specifically, these are the same areas as those with the reserves -32-.

[0020] Following sufficient description of the nature of the invention, as well as an example of the preferred embodiment, it is hereby recorded for all appropriate purposes that the materials, shape, size and arrangement of the components described may be modified, whenever such does not require a change in the essential characteristics of the invention claimed hereafter.

blem involved being printed on said sheet, with reserves (32) on the areas set aside for the luminous motifs, a layer (4) of transparent conductive ink, a layer (5) of electroluminescent phosphor applied on the areas or motifs to be lighted, an initial layer (6) of silver-based conductive ink, a layer (7) of dielectric polymer, a second layer (8) of silver-based conductive ink, a layer (9) of nonconducting ink and a base layer (10) of white paint; the representative motifs (31) of the emblem being printed on the back surface of the aforementioned; the laminar body (2) being eventually equipped with a supporting component (1) which provides for fastening, hanging, securing or hooking.

2. Emblem according to the prior claims characterised in that the layer (4) of transparent conductive ink is applied on the areas corresponding to the luminous motifs and on the reserves (32) indicated by the printing of the motifs (31) on the transparent sheet (3).
3. Emblem according to the prior claims characterised in that the layer (4) of transparent conductive ink is electrically connected to the second layer (8) of silver-based conductive ink.
4. Emblem according to the prior claims characterised in that the layers (6,8) of silver-based conductive ink are each equipped with feed tracks (61, 81) for connection, through a switch (12), to a low-amperage power source.

Claims

1. Emblem with luminous motifs as a flag, a coat of arms or other similar figure, characterised by a laminar body (2) formed by a sheet (3) of transparent material; the representative motifs (31) of the em-

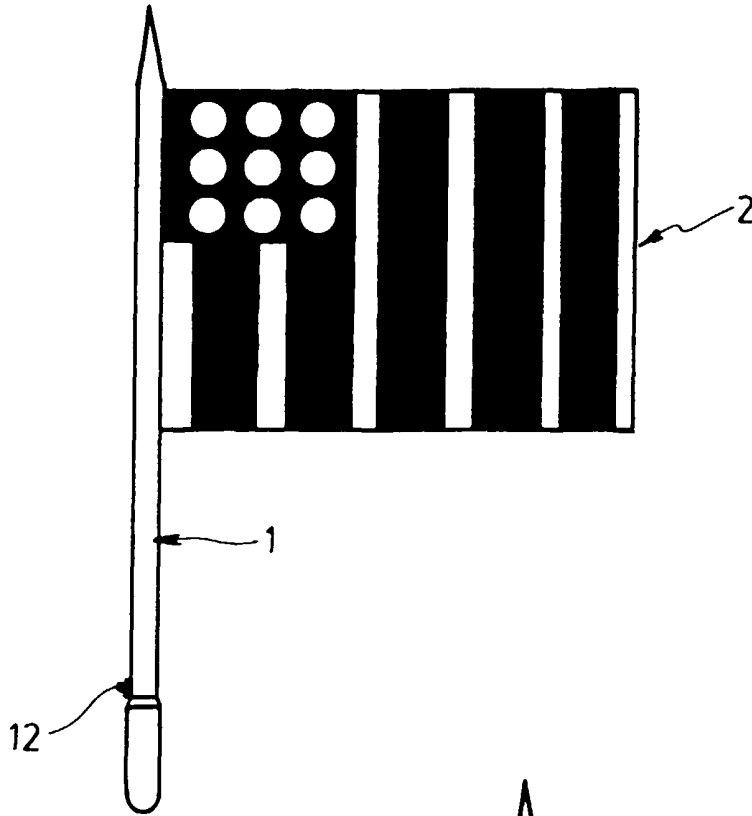

FIG. 1

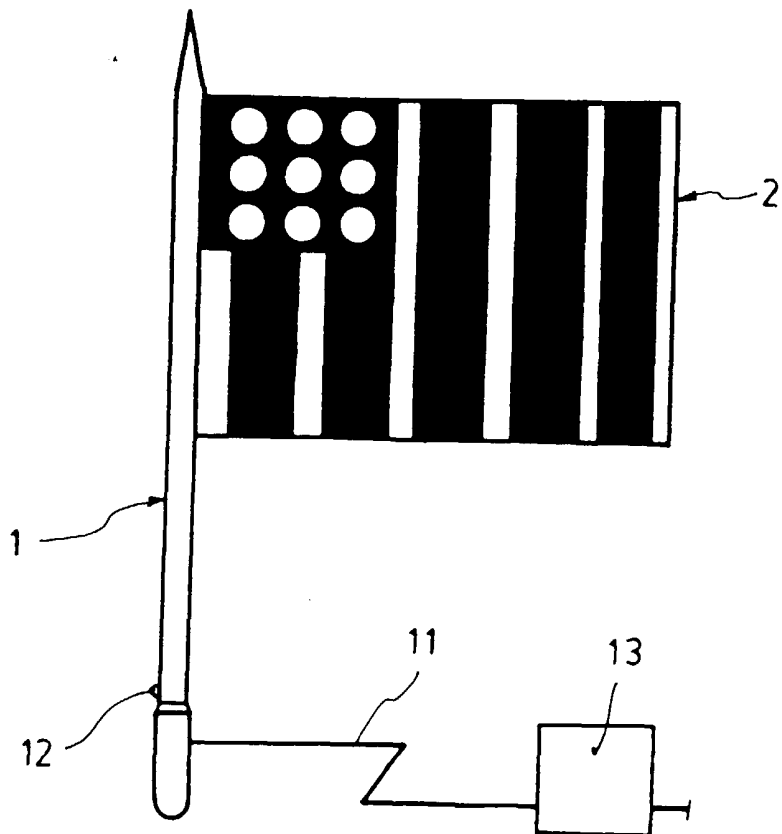

FIG. 2

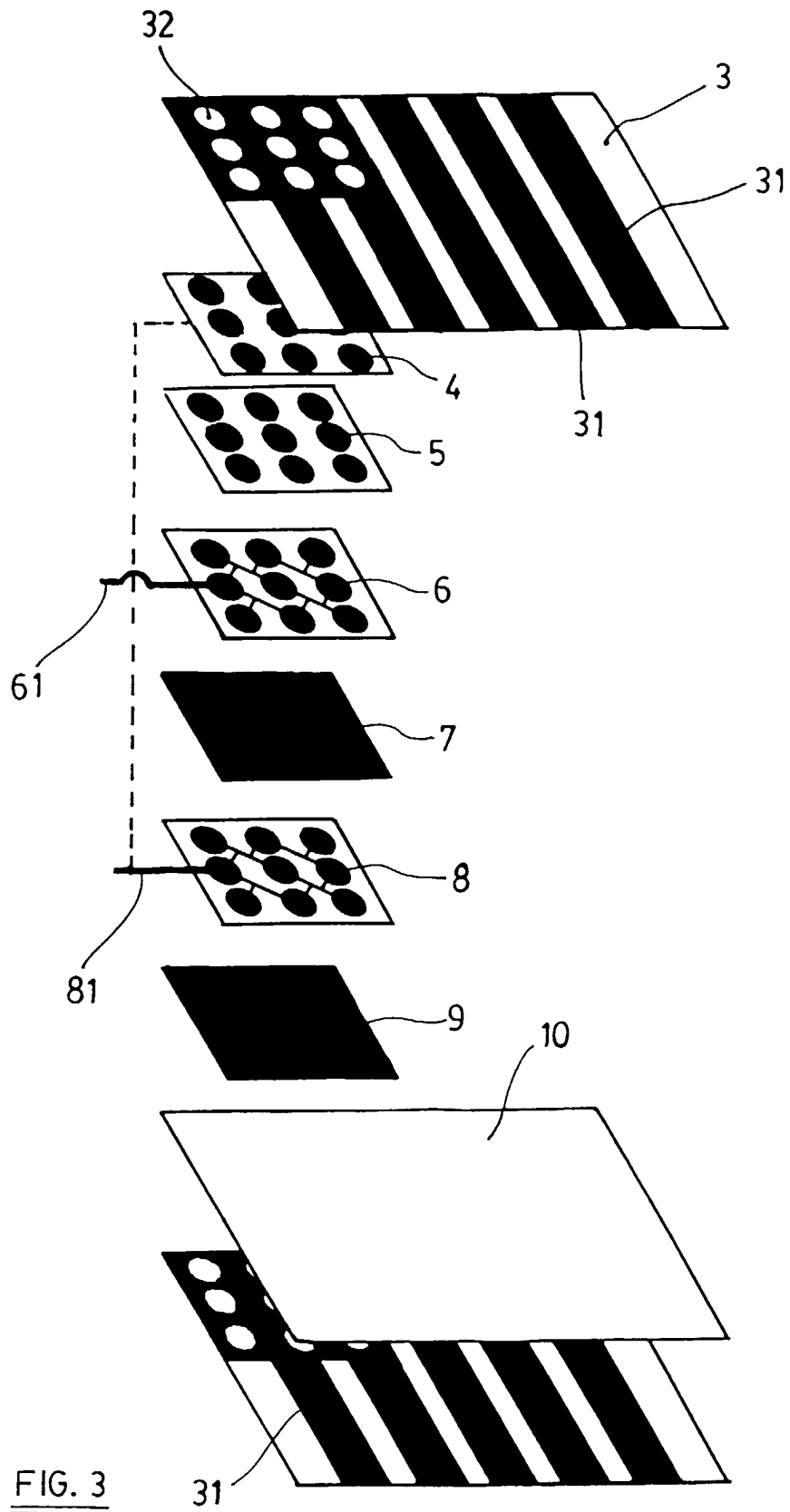

FIG. 3



European Patent
Office

EUROPEAN SEARCH REPORT

Application Number
EP 99 50 0207

DOCUMENTS CONSIDERED TO BE RELEVANT			
Category	Citation of document with indication, where appropriate, of relevant passages	Relevant to claim	CLASSIFICATION OF THE APPLICATION (Int.Cl.7)
A	US 5 794 366 A (CHIEN TSENG-LU) 18 August 1998 (1998-08-18) * column 3, line 27 - line 57 *		B41M5/20 B41M3/00 G09F13/22
A	GB 2 233 139 A (SPECIALIST PRINTERS LTD) 2 January 1991 (1991-01-02) * page 2, line 21 - page 3, line 19 *	1	
A	GB 2 240 206 A (ZANUSSI A SPA INDUSTRIE) 24 July 1991 (1991-07-24) * page 2, line 19 - page 3, line 34 *	1	
			TECHNICAL FIELDS SEARCHED (Int.Cl.7)
			B41M G09F B44F
The present search report has been drawn up for all claims			
Place of search		Date of completion of the search	Examiner
THE HAGUE		19 April 2000	Herrmann, J
CATEGORY OF CITED DOCUMENTS			
X : particularly relevant if taken alone Y : particularly relevant if combined with another document of the same category A : technological background O : non-written disclosure P : intermediate document		T : theory or principle underlying the invention E : earlier patent document, but published on, or after the filing date D : document cited in the application L : document cited for other reasons & : member of the same patent family, corresponding document	

EPC FORM 1503.03.82 (P/4C01)

**ANNEX TO THE EUROPEAN SEARCH REPORT
ON EUROPEAN PATENT APPLICATION NO.**

EP 99 50 0207

This annex lists the patent family members relating to the patent documents cited in the above-mentioned European search report. The members are as contained in the European Patent Office EDP file on
The European Patent Office is in no way liable for these particulars which are merely given for the purpose of information.

19-04-2000

Patent document cited in search report	Publication date	Patent family member(s)	Publication date
US 5794366 A	18-08-1998	US 5752337 A US 5572817 A US 5833508 A	19-05-1998 12-11-1996 10-11-1998
GB 2233139 A	02-01-1991	NONE	
GB 2240206 A	24-07-1991	IT 223858 Z DE 9100205 U ES 2034916 A FR 2656946 A	03-10-1995 28-03-1991 01-04-1993 12-07-1991