



AU9473411

(12) PATENT ABRIDGMENT (11) Document No. AU-B-73411/94
(19) AUSTRALIAN PATENT OFFICE (10) Acceptance No. 684531

- (54) Title
COOKING ARRANGEMENTS
- International Patent Classification(s)
(51)⁵ **A23L 001/01 A47J 037/00 A47J 037/04 A47J 037/06**
- (21) Application No. : **73411/94** (22) Application Date : **27.07.94**
- (87) PCT Publication Number : **WO95/03713**
- (30) Priority Data
- (31) Number (32) Date (33) Country
44236/93 27.07.93 AU AUSTRALIA
- (43) Publication Date : **28.02.95**
- (44) Publication Date of Accepted Application : **18.12.97**
- (71) Applicant(s)
PENNY HLAVATY
- (72) Inventor(s)
PENNY HLAVATY
- (74) Attorney or Agent
GRIFFITH HACK , GPO Box 4164, SYDNEY NSW 2001
- (56) Prior Art Documents
US 5044264
US 4987828
EP 105056
- (57) Claim

1. An apparatus for substantially continuous cooking operations comprising means for supporting food items to be conveyed along a cooking path from an inlet station to a discharge station, heat transfer means, heating means for heating the heat transfer means at a location remote from the cooking path and prior to receiving the food items at the commencement of the cooking path, means for moving the heat transfer means into contact with the food items to effect cooking as the food items are moved along the cooking path, the heat transfer means gradually reducing in temperature along the path, and means for moving the heat transfer means from the discharge station back to the heating means for reheating prior to further cooking operations.

(11) AU-B-73411/94
(10) 684531

-2-

2. An apparatus for substantially continuous cooking operations comprising means for supporting food items to be conveyed along a cooking path from an inlet station to a discharge station, heat transfer means, heating means for heating the heat transfer means such that they have a predetermined first temperature prior to receiving the food items at the commencement of the cooking path and have a second predetermined temperature at the end of the cooking path, means for moving the heat transfer means adjacent to the food items to effect cooking as the food items are moved along the cooking path, the heat transfer means gradually reducing in temperature over most of the path, and means for moving the heat transfer means from the discharge station back to the inlet station for reheating prior to further cooking operations.



| | | |
|---|---|--|
| <p>(51) International Patent Classification ⁶ : A23L 1/01, A47J 37/00, 37/04, 37/06</p> | <p>A1</p> | <p>(11) International Publication Number: WO 95/03713 (43) International Publication Date: 9 February 1995 (09.02.95)</p> |
| <p>(21) International Application Number: PCT/AU94/00429 (22) International Filing Date: 27 July 1994 (27.07.94) (30) Priority Data: 44236/93 27 July 1993 (27.07.93) AU (71)(72) Applicant and Inventor: HLAVATY, Penny [AU/AU]; 34 Germain Avenue, Bateau Way, NSW 2261 (AU). (74) Agent: GRIFFITH HACK & CO.; GPO Box 4164, Sydney, NSW 2001 (AU).</p> | <p>(81) Designated States: AM, AT, AU, BB, BG, BR, BY, CA, CH, CN, CZ, DE, DK, ES, FI, GB, GE, HU, JP, KE, KG, KP, KR, KZ, LK, LT, LU, LV, MD, MG, MN, MW, NL, NO, NZ, PL, PT, RO, RU, SD, SE, SI, SK, TJ, TT, UA, US, UZ, VN, European patent (AT, BE, CH, DE, DK, ES, FR, GB, GR, IE, IT, LU, MC, NL, PT, SE), OAPI patent (BF, BJ, CF, CG, CI, CM, GA, GN, ML, MR, NE, SN, TD, TG), ARIPO patent (KE, MW, SD).</p> <p>Published With international search report.</p> <p>684531</p> | |

(54) Title: COOKING ARRANGEMENTS

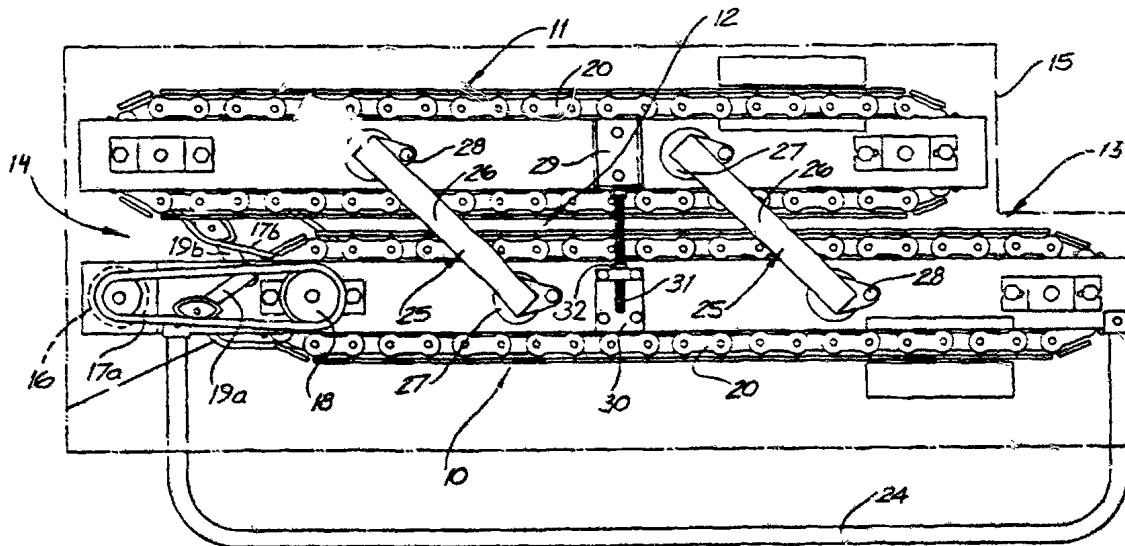

(57) Abstract

An apparatus for substantially continuous cooking operations comprises means (such as a conveyor arrangement) for supporting food items to be conveyed along a cooking path from an inlet station to a discharge station, heat transfer means (such as plates associated with the conveyor arrangement), heating means for heating the heat transfer means at a location remote from the cooking path, means for moving the heat transfer means into contact with the food items to effect cooking as the food items are moved along the cooking path whereby the heat transfer means gradually reduce in temperature along the path, and means for moving the heat transfer means from the discharge station back to the heating means for reheating prior to further cooking operations.

- 1 -

COOKING ARRANGEMENTS

The present invention relates to cooking arrangements and is more particularly concerned with methods and apparatus which can be particularly useful in commercial circumstances such as food factory and restaurant operations.

Particularly in commercial applications, there has been a long standing need to provide cooking arrangements for various items of foods whereby a very well controlled and predictable cooking process can be conducted preferably on a continuous or semi-continuous basis so that a high volume output with good quality control can be achieved. For different types of dishes various different cooking techniques may be required. Although limited options have been available, none is capable of performing certain types of cooking procedures in an effective continuous or semi-continuous operation. More particularly, the present invention can apply to broiling, grilling, chargrilling and other techniques similar to saute or stir-fry cooking processes. An important class of cooking processes to which the invention is applicable are those where searing or sealing of the food item is effected followed by maintenance of appropriate temperature condition as to effect the desired cooking.

The present invention offers new and useful alternatives to prior proposals.

According to the present invention there is provided, in a first aspect, an apparatus for substantially continuous cooking operations comprising means for supporting food items to be conveyed along a cooking path from an inlet station to a discharge station, heat transfer means, heating means for heating the heat transfer means at a location remote from the cooking path and prior to receiving the food items at the commencement of the cooking path, means for moving the heat transfer means into contact with the food items to effect cooking as the food items are moved along the

- 2 -

cooking path, the heat transfer means gradually reducing in temperature along the path, and means for moving the heat transfer means from the discharge station back to the heating means for reheating prior to further cooking operations.

5 In a second aspect there is provided an apparatus for substantially continuous cooking operations comprising means for supporting food items to be conveyed along a cooking path from an inlet station to a discharge station, heat transfer means, heating means for heating the heat transfer means such that they have a predetermined first temperature prior to receiving the food items at the commencement of the cooking path and have a second predetermined temperature at the end of the cooking path, means for moving the heat transfer means into contact with the food items to effect cooking as the food items are moved along the cooking path whereby the heat transfer means over most of the path gradually reduce in temperature along the path, and means for moving the heat transfer means from the discharge station back to the inlet station for reheating prior to further cooking operations.

10 In a preferred embodiment, a series of elements provide both the heat transfer means and the means for supporting the food items; the apparatus is arranged as a continuous conveying apparatus with the series of elements arranged to move along a closed loop.

15 The series of elements may be mounted between a pair of spaced chains running over respective sprockets and driven by a continuous drive system. However, other options exist such as tracks coated with PTFE.

20 One important embodiment is one in which the heat transfer means are arranged to engage opposite sides of the food items as they are moved along the cooking path. This can readily be achieved by upper and lower counter rotating conveyor systems having a respective series of preheated elements which are brought into contact with the food at the inlet station, and which during movement

- 3 -

along the cooking path to the discharge station reduce their temperature. The food therefore stays in the apparatus for a predetermined time in which the temperature of the respective upper and lower elements being in contact with a food item drops from an initial value, predetermined by the initial temperature imparted by the heating element, to a second value determined by the heat transfer and radiation properties of the elements.

10 In a further advantageous embodiment, the apparatus is preferably provided with heating means which include a first heater arranged for heating the heat transfer means at a location remote from the cooking path and prior to the inlet station, and a second heater arranged along at least a portion of the cooking path and being adapted to controllably impart to the heat transfer means a desired falling temperature profile along the cooking path.

20 Preferably the apparatus is provided with adjusting means which enable accommodation of food items of different dimensions. For example, food items of different thicknesses can be accommodated by an adjustment in the vertical spacing between the upper and lower conveyor systems.

25 Preferably, means are provided which bias the elements of the upper and lower counter rotating conveyor system into contact with the food item received thereinbetween such that an appropriate degree of pressure is applied thereto. The biasing force can be applied to the upper, the lower or both conveyor systems.

30 Implementation of one or more of the above inventive concepts permits the manufacture of a compact apparatus which can nevertheless provide a high throughput with very accurate control of the cooking process.

35 Embodiments of the apparatus can be used for diverse products such as hamburgers and steaks but also can be used, for example, for cooking portions of stir-fry meats and vegetables.

Furthermore, for the purpose of good presentation, a

- 4 -

selected pattern may be used on the surface of each heat transfer element. For example, a grid pattern could be used but also other patterns including logos can be used with great effect particularly for making items such as steaks.

5

Experiments have established that embodiments of the invention can operate efficiently and can prevent burning or stewing of meat. For example, having the heat transfer elements at a starting temperature selected in the range of 200 to 300°C with a cooking path designed to cool the elements to approximately 100°C at the end of the cooking path has been found to be effective; however, experimentation with food items of different sizes and types will indicate the preferred operating conditions for the particular food item.

10

15

Various forms of heating can be used such as induction heating, gas heating, electrical heating and the like.

20

Preferred versions of the inventive apparatus may include insulation hoods, thus making the use of the apparatus very energy efficient.

25

It is also possible to design embodiments so that they can be readily adjustable to suit different products and operating conditions. This can be important because precise control of the cooking process can have an important impact not only on appearance but also when controlling the changes in the food which occur in the cooking process.

30

The apparatus according to the invention may be provided with control means to allow automatic adjustment and/or setting of cooking parameters such as initial temperature of the elements in the inlet station, conveyor speed and the like, to cater for different cooking requirements for different foodstuffs.

35

For illustrative purposes, embodiments of the invention will now be described with reference to the accompanying drawings. The embodiments described are of a conveyor type design but it should be understood that

- 5 -

other configurations of the invention are possible including carousel type machines. Furthermore adaptation of the design would permit a multiplicity of different tracks, for example in parallel, to be provided, each track constituting a particular cooking path characterised by particular temperature and speed conditions.

Referring now to the accompanying drawings,

Figure 1 is a front elevation of an embodiment of the invention;

Figure 2 is an end elevation of the embodiment of Figure 1;

Figure 3 is a rear elevation of the apparatus; and

Figure 4 is a front elevation of a further embodiment of the invention.

The embodiments shown in the drawings are intended for small scale commercial use and comprises a double conveyor arrangement consisting of a lower conveyor 10, an upper conveyor 11, an inlet station 13, discharge station 14 and an insulated hood 15. Between the conveyors and between the inlet and discharge stations is defined a cooking path 12 which is linear. The conveyors are adapted to be driven by an electric motor 16 through drive belts 17a and 17b, which runs over respective pulleys 18. The belt is tensioned by a spring biased tensioning arms 19a and 19b.

Each of the conveyors comprises a pair of parallel spaced chains 20 bridged by a continuous series of strip like plates 21 which act as the heat transfer elements. The chains run over respective sprocket wheels one of which is driven at a constant speed.

The sprocket wheels are mounted rotatably on side frames 23 and the lower conveyor has its side frame support on a leg work 24. The upper conveyor is supported through an adjustable mounting structure which comprises a pair of parallel pivotable support arms 25 at the rear of the machine, the support arms comprising square cross section cubes 26 pivotally mounted about

- 6 -

horizontal axes to mounting plates 27 which are secured to the respective side frames by screws 28.

The desired spacing between the conveyors 10, 11 is controlled by an adjustment mechanism at each side of the machine and comprising upper and lower mounting brackets 29 and 30 and a screw 31 which is threadably engaged in a nut 32. Rotation of the nut adjusts the vertical separation or spacing of the conveyors on each side of the machine.

10 In the embodiment according to Figures 1 to 3, induction heating is provided to heat up the plates 21 of the upper and lower conveyors 10 and 11; alternative heating systems employing gas, electricity and the like could also be used. In the illustrated embodiment
15 induction heating units 33 are schematically shown near the inlet station 13 of the apparatus but adjacent to the plates 21 in their return path remote from the cooking path 12. The units 33 provide for very rapid heating of the plates so that the desired high temperature subsists
20 when the food items come into initial contact with the plates 21; subsequently, the plates 21 gradually transfer heat to the food item thereby reducing their initial temperature when moving in the downstream direction along the cooking path 12 to provide an
25 efficient and accurately controllable cooking process.

In the embodiment according to Figure 4, which is substantially identical to the embodiments described with reference to Figures 1-3 and therefore similar reference numerals have been used to denote corresponding parts,
30 the heating system used in the apparatus is different to the one described above. The heating system comprises an induction heating unit 33' similarly arranged and located as described with reference to the embodiments in Figures 1-3. A further heating unit 34 is arranged along the
35 cooking path 12 adjacent to the plates 21 of the upper and the lower conveyors 10, 11, respectively. This further heating units 34 can, for example, be a set of thick metal plates with variable heating elements

- 7 -

disposed therein. The heating elements themselves can be electric coils embedded into the metal plates or induction heaters or other suitable heating elements. The heating elements are controlled in such a manner that a falling temperature profile along the cooking path 12 is maintained, such that the plates 21 also have a corresponding temperature along the path. In contrast to the embodiment of Figures 1-3, where the plates 21, after initial preheating, were allowed to cool off along the cooking path 12 thereby transferring heat to the food item, the plates 21 in the embodiment of Figure 4 are constantly heated by the heating unit 34 to a desired temperature which declines along the cooking path 12. In a variation of this embodiment not depicted in the Figures, the preheating unit 33' could be omitted completely as long as it is ensured that the heating unit 34 of the lower conveyor 10 heats the plates 21 at the inlet station quickly and sufficiently to a predetermined temperature to effect sealing of a food item disposed thereon and prior to further conveyance through the apparatus.

The plates can be of any suitable materials such as cast iron or ceramic but in general a high thermal capacity needs to be provided.

In yet a further unillustrated embodiment, the above described conveyor having separate heat transfer plates adjacently aligned along the conveyor chains is substituted by a flexible continuous conveyor band, stainless steel fine metal mesh band coated with a non-stick surface or other permitted materials which can equally be heated up to a desired inlet station temperature. It will be further appreciated that means for biasing the plates of the upper and lower conveyors (or the conveyor bands) towards another such as to sandwich a food item received thereinbetween can be provided in order to ensure appropriate contact of the heating plate on both sides of the food item and improve cooking thereof. The provision of a preferably light

pressure on the food items conveyed between the heat transfer plate enhances the heat transfer into the food.

It is self understood that the above described apparatuses are provided with controllers for adjusting independently or in dependence of one another the conveyor speed and the temperature in the heating unit 33 (and 34) to obtain optimal cooking process conditions for different foodstuffs. The control can also be effected automatically.

It will be appreciated that the embodiments illustrated are only examples. In common with all cooking apparatus, the design should permit regular and easy cleaning and, where necessary, disassembly for cleaning purposes. The illustrated embodiments permit ordinary operators rather than mechanics to adjust and maintain the machine and by a simple control of operating speed and heater temperatures a range of different cooking conditions can be provided. Furthermore by easy adjustment of the vertical separation between the conveyor units, adaptation can take place to suit food items of different thickness. Usually it is desired (particularly for products like steaks) to have contact on both sides of the steak although light contact on the upper side is usually sufficient.

Although the embodiments illustrated show a conveyor system in which the upper conveyor is parallel to the lower conveyor, provision can be made for other forms of configuration and adjustment including tapering the gap between the conveyors to accommodate for food shrinkage.

- 9 -

CLAIMS

1. An apparatus for substantially continuous cooking operations comprising means for supporting food items to be conveyed along a cooking path from an inlet station to a discharge station, heat transfer means, heating means for heating the heat transfer means at a location remote from the cooking path and prior to receiving the food items at the commencement of the cooking path, means for moving the heat transfer means into contact with the food items to effect cooking as the food items are moved along the cooking path, the heat transfer means gradually reducing in temperature along the path, and means for moving the heat transfer means from the discharge station back to the heating means for reheating prior to further cooking operations.

2. An apparatus for substantially continuous cooking operations comprising means for supporting food items to be conveyed along a cooking path from an inlet station to a discharge station, heat transfer means, heating means for heating the heat transfer means such that they have a predetermined first temperature prior to receiving the food items at the commencement of the cooking path and have a second predetermined temperature at the end of the cooking path, means for moving the heat transfer means adjacent to the food items to effect cooking as the food items are moved along the cooking path, the heat transfer means gradually reducing in temperature over most of the path, and means for moving the heat transfer means from the discharge station back to the inlet station for reheating prior to further cooking operations.

3. Apparatus as claimed in claim 1 or 2, wherein a series of elements provide both the heat transfer means and the means for supporting the food items and the apparatus is arranged as a continuous conveying apparatus with the series of elements arranged to move along a closed loop.

4. Apparatus as claimed in claim 1, 2 or 3, wherein

the heat transfer means and the means for moving the heat transfer means are in the form of upper and lower counter-rotating conveyor systems, each conveyor system having a respective series of heat transfer means arranged to contact the food on an upper and lower side thereof for a predetermined time as the food is moved along the cooking path, the temperature of the heat transfer means reducing during the passage along the cooking path.

10 5. An apparatus for substantially continuous cooking operations according to claim 2, wherein the heating means include a first heater arranged for heating the heat transfer means at a location remote from the cooking path and prior to the inlet station, and a second
15 heater arranged along at least a portion of the cooking path and being adapted to controllably impart to the heat transfer means a desired falling temperature profile along the cooking path.

20 6. An apparatus for substantially continuous cooking operations as claimed in claim 4 or 5, wherein the conveyor systems include a heat transfer means, a series of plate like elements adjacently mounted between a pair of parallel spaced chains running over respective sprockets and driven by a continuous drive system.

25 7. An apparatus for substantially continuous cooking operations as claimed in claim 4 or 5, wherein the upper and lower conveyor systems have a closed loop continuous heat transfer band.

30 8. An apparatus for substantially continuous cooking operations as claimed in any one of claims 4 to 7, wherein adjustment means are provided to adjust the spacing between the respective series of heat transfer means of the upper and lower conveyor systems.

35 9. An apparatus for substantially continuous cooking operations as claimed in any one of claims 4 to 8, wherein means are provided to bias the elements of the upper and lower conveyor systems into contact with a food item received thereinbetween such that an appropriate

- 11 -

degree of pressure is applied to the food item.

10. An apparatus for substantially continuous cooking operations according to claim 9, wherein the heat transfer band has a mesh like structure, preferably a
5 coated metal mesh endless band.

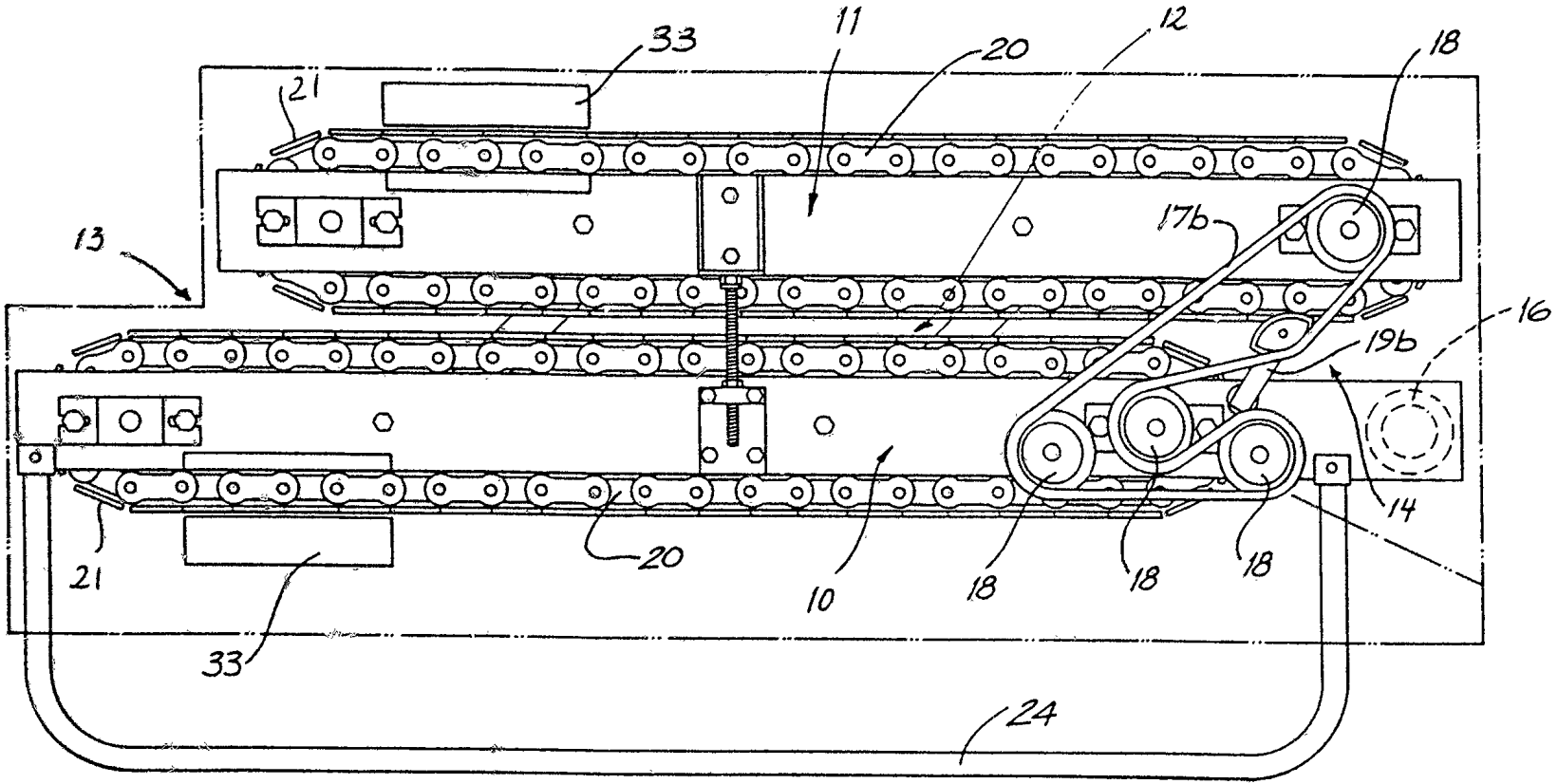

FIG. 1

2/4

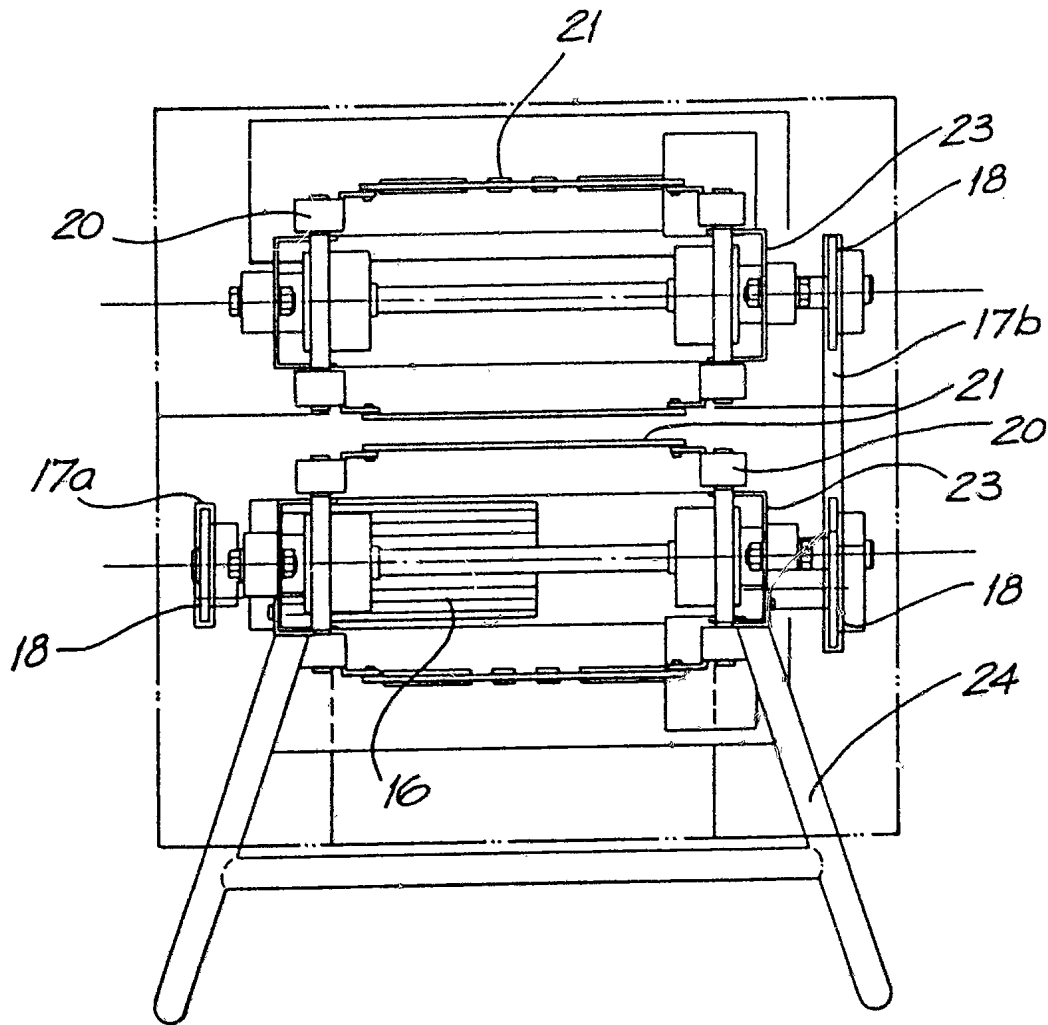

FIG. 2

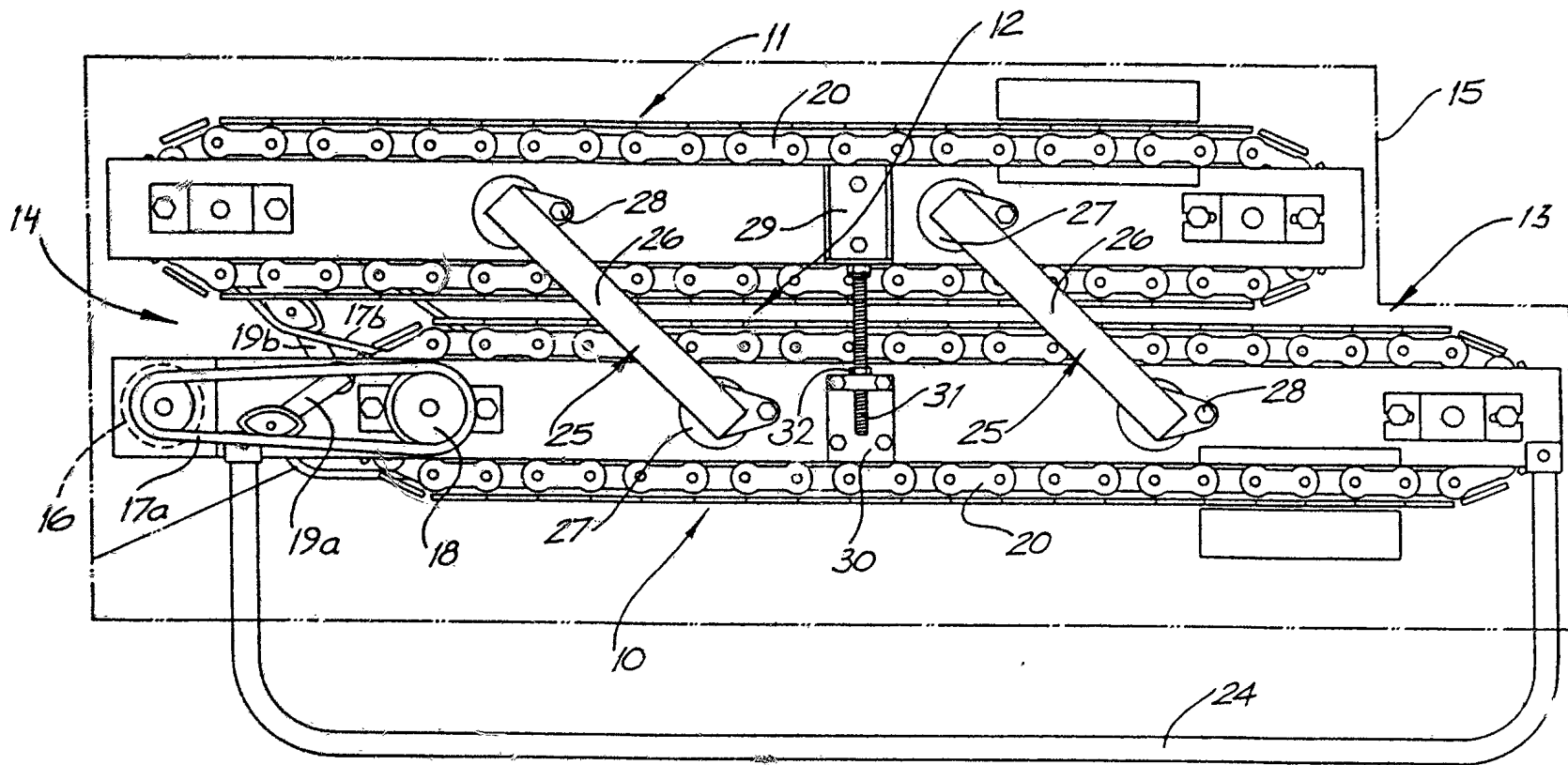

FIG. 3

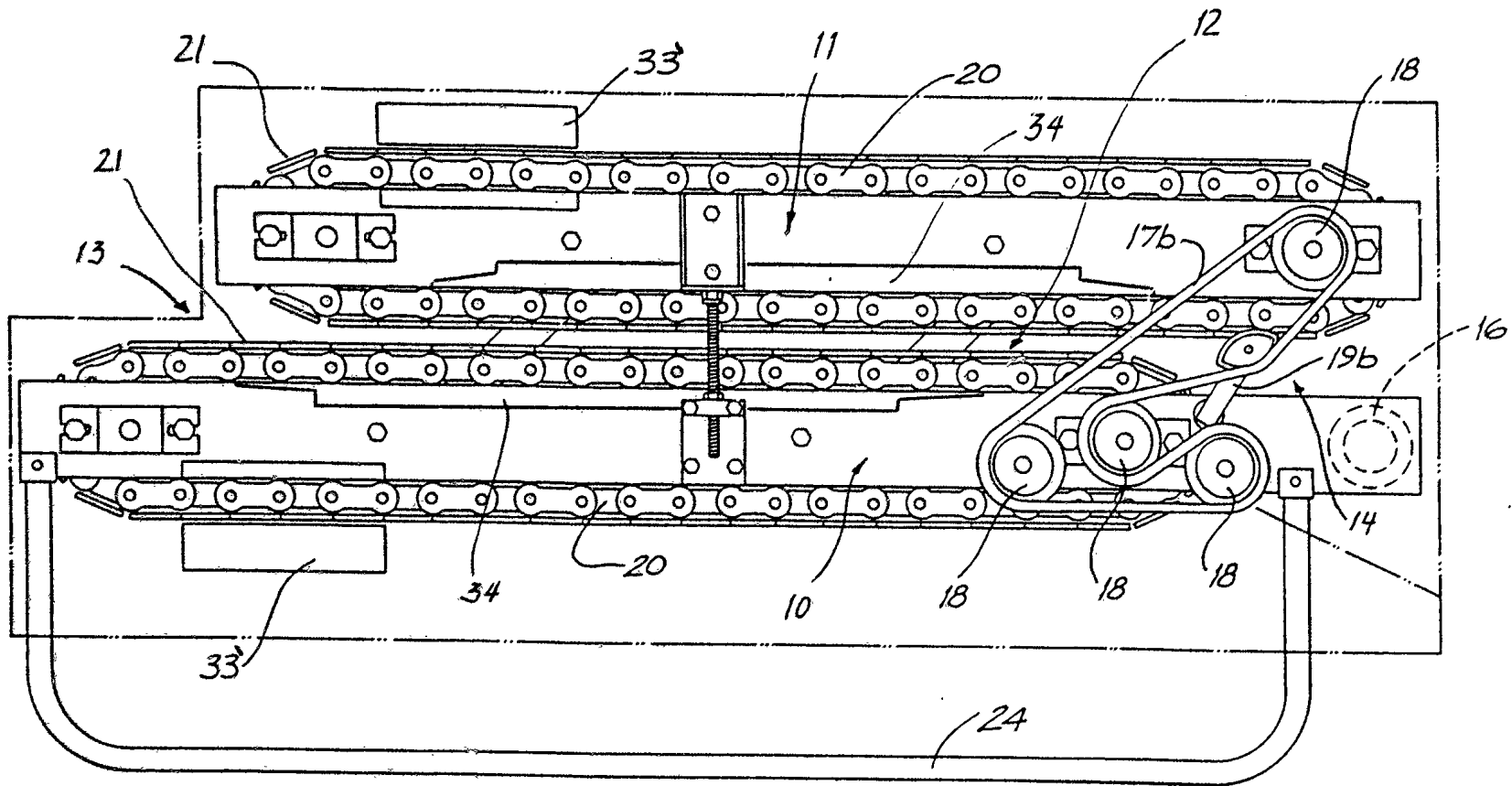



FIG. 4

INTERNATIONAL SEARCH REPORT

| | | |
|--|---|--|
| A. CLASSIFICATION OF SUBJECT MATTER Int. Cl. ⁶ A23L 1/01, A47J 37/00, 37/04, 37/06 According to International Patent Classification (IPC) or to both national classification and IPC | | |
| B. FIELDS SEARCHED Minimum documentation searched (classification system followed by classification symbols) IPC: A23L 1/01, A47J 37/00, 37/04, 37/06 Documentation searched other than minimum documentation to the extent that such documents are included in the fields searched AU: IPC as above, AU Class 35.67 Electronic data base consulted during the international search (name of data base, and where practicable, search terms used) DERWENT:CONVYER: and HEAT: and FOOD: and COOK: Food Science Technology Abstracts:AS ABOVE and APPARATUS or MACHINE: or EQUIPMENT AND CONTACT: or TOUCH: or MEET: | | |
| C. DOCUMENTS CONSIDERED TO BE RELEVANT | | |
| Category* | Citation of document, with indication, where appropriate, of the relevant passages | Relevant to Claim No. |
| A | US,A, 5044264 (FORNEY) 3 September 1991 (3.09.91) | |
| A | US,A, 4987828 (NUNS, GIRAULT) 29 January 1991 (29.01.91) | |
| A | EP,A, 105056 (NESTLE S.A) 11 April 1984 (11.04.84) | |
| <input type="checkbox"/> Further documents are listed in the continuation of Box C. <input checked="" type="checkbox"/> See patent family annex. | | |
| * Special categories of cited documents : | | |
| "A" | document defining the general state of the art which is not considered to be of particular relevance | "T" later document published after the international filing date or priority date and not in conflict with the application but cited to understand the principle of theory underlying the invention |
| "E" | earlier document but published on or after the international filing date | "X" document of particular relevance; the claimed invention cannot be considered novel or cannot be considered to involve an inventive step when the document is taken alone |
| "L" | document which may throw doubts on priority claim(s) or which is cited to establish the publication date of another citation or other special reason (as specified) | "Y" document of particular relevance; the claimed invention cannot be considered to involve an inventive step when the document is combined with one or more other such documents, such combination being obvious to a person skilled in the art |
| "O" | document referring to an oral disclosure, use, exhibition or other means | "&" document member of the same patent family |
| "P" | document published prior to the international filing date but later than the priority date claimed | |
| Date of the actual completion of the international search 15 November 1994 (15.11.94) | Date of mailing of the international search report 18 Nov 1994 (18.11.94) | |
| Name and mailing address of the ISA/AU AUSTRALIAN INDUSTRIAL PROPERTY ORGANISATION PO BOX 200 WODEN ACT 2606 AUSTRALIA Facsimile No. (06) 2853929 | Authorized officer  ANDREW ACHILLEOS Telephone No. (06) 2832280 | |

INTERNATIONAL SEARCH REPORT

Information on patent family membe.

International application No.

PCT/AU 94/00429

This Annex lists the known "A" publication level patent family members relating to the patent documents cited in the above-mentioned international search report. The Australian Patent Office is in no way liable for these particulars which are merely given for the purpose of information.

| Patent Document Cited in Search Report | | Patent Family Member | | | | | |
|--|---------|----------------------|----------|----|----------|----|---------|
| US | 5044264 | EP | 531456 | WO | 9212661 | | |
| US | 4987828 | CA | 1306512 | FR | 2623691 | EP | 320337 |
| | | JP | 1196247 | | | | |
| EP | 105056 | AU | 18661/83 | BR | 8305447 | CA | 1200412 |
| | | DK | 4307/83 | ES | 526209 | ES | 8405604 |
| | | FI | 833485 | JP | 59088121 | NO | 833544 |
| | | NZ | 205465 | PT | 76942 | VS | 4565704 |
| | | ZA | 8306960 | | | | |
| END OF ANNEX | | | | | | | |