

Oct. 9, 1962

C. J. WARNSDORFER, JR., ET AL

3,057,536

CONTAINER

Filed Dec. 28, 1960

2 Sheets-Sheet 1

Fig. 1.

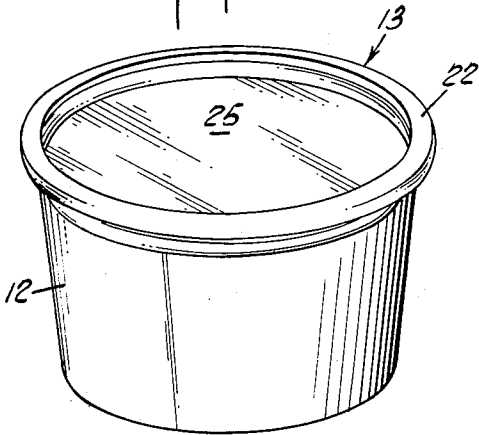

Fig. 4.

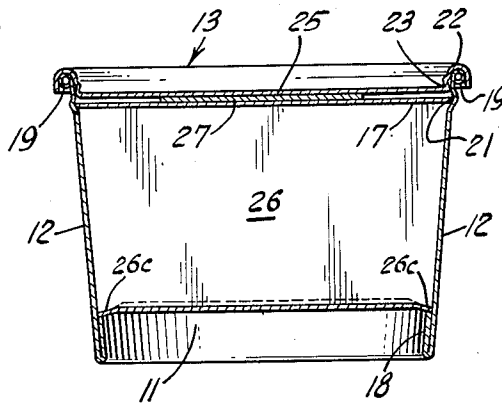

Fig. 2.

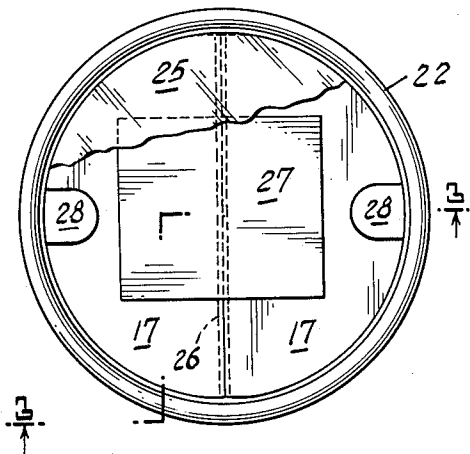

Fig. 5.

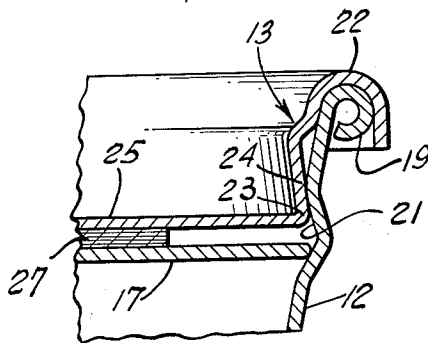

Fig. 6.

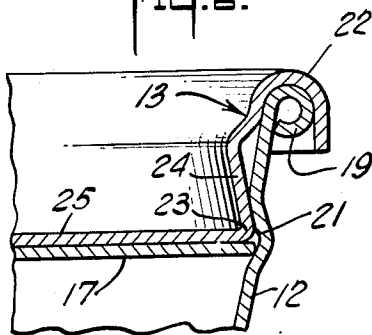
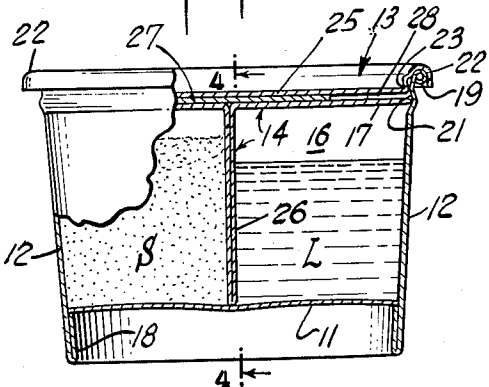

Fig. 3.



INVENTORS:
JOHN S. BABIY
WILLIAM S. FERENCZY
BY CLIFFORD J. WARNSDORFER

Charles A. Harris
ATTORNEY

Oct. 9, 1962

C. J. WARNSDORFER, JR., ET AL

3,057,536

CONTAINER

Filed Dec. 28, 1960

2 Sheets-Sheet 2

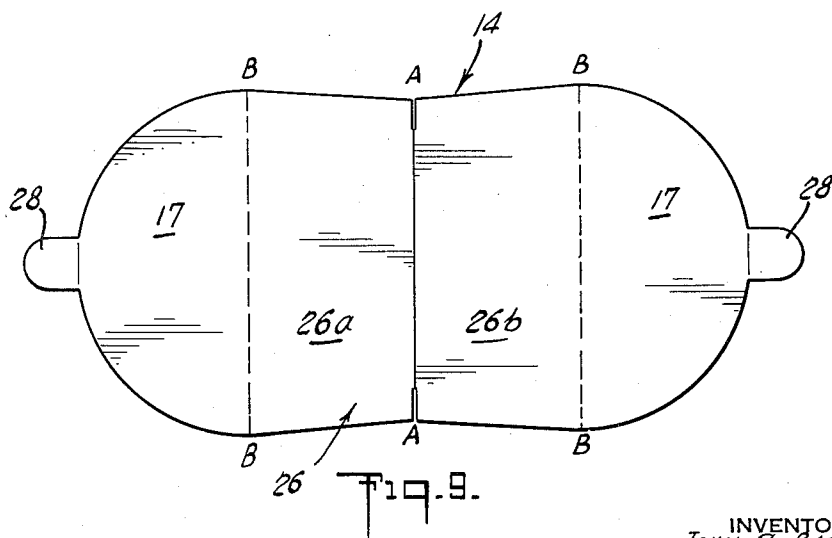
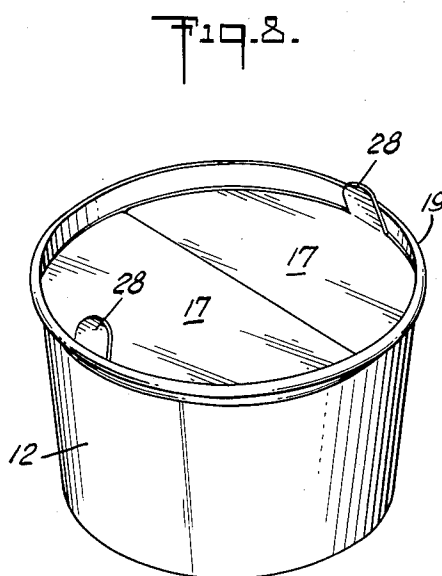
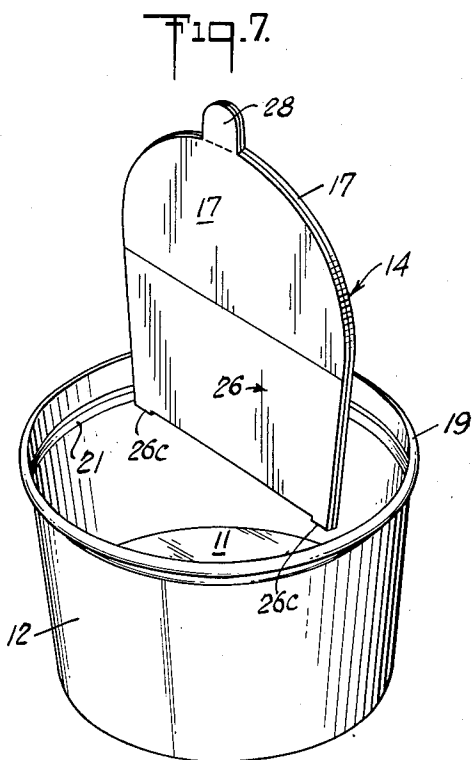

INVENTORS:
JOHN S. BABY
WILLIAM J. FERENCY
BY CLIFFORD J. WARNSDORFER
Charles A. Harris
ATTORNEY

1

3,057,536
CONTAINER

Clifford J. Warnsdorfer, Jr., South River, William J. Ferenczy, East Brunswick, and John S. Babiy, Highland Park, N.J., assignors to Johnson & Johnson, a corporation of New Jersey

Filed Dec. 28, 1960, Ser. No. 78,953
5 Claims. (Cl. 229-42)

The present invention relates to bicameral, or two-compartment, containers of the type having a divider which is adapted to be removed to allow intermixture of the contents of the compartments.

The present invention contemplates a relatively rigid, two-compartment container for materials which must be kept separate during shipment and storage on the shelf, but which are intermixed prior to, or during, use. Such materials include epoxy resins and hardeners, two flavors of ice cream, particularly when it is desired to maintain one flavor distinct from another, different kinds of vegetables, and the like.

More particularly, the present invention contemplates a substantially rigid container which is divided into two compartments, each of which has a separate inner lid, by a single closure member having a vertical divider portion and a pair of horizontal lid portions extending in opposite directions from the top of the divider portion. The container comprises a bottom section and a side wall extending upwardly from the perimeter of the bottom section all around the perimeter. The side wall contains an annular recess extending around the container just below its top edge. A cap is provided which fits onto the top edge of the side wall, and has a depressed portion which fits into the annular recess in the side wall to provide a snap-fit between the cap and the wall.

When the cap is positioned on the side wall, the depressed portion of the cap presses the divider portion and the lid portions of the closure into close fitting relation with corresponding portions of the bottom section and the side wall of the container to provide two separate compartments each having a lid formed by the closure portion.

The contents of either of the compartments of the container may be inspected independently of the other, merely by removing the cap and lifting the lid portion of the compartment involved. Similarly, the compartments may be filled independently of one another and closed independently merely by pressing down the lid portion over the filled compartment. The lid portion, or portions, advantageously may be left unstanding during filling of one or both of the compartments to add height to the divider and prevent spillage into the wrong compartment.

The contents of the compartments may be intermixed merely by pulling upwards on a tab provided at the end of one of the lid portions to remove the closure portion, and then mixing with a spatula or a similar device, if necessary.

Other and further advantages of the invention will be apparent from the following description and claims taken together with the drawings, wherein:

FIG. 1 is a view in perspective of a bicameral container according to one embodiment of this invention.

FIG. 2 is a top plan view, of the container of FIG. 1, partially broken away to show the inner lid portions of the container and other features thereof.

FIG. 3 is a view partly in section and partly in elevation taken along the line 3-3 of FIG. 2.

FIG. 4 is a view partly in section and partly in elevation along the line 4-4 of FIG. 3.

FIG. 5 is a greatly enlarged view showing the relationship between the cap, the top edge of the side wall and an inner lid portion of the container of FIG. 1.

2

FIG. 6 is a greatly enlarged view similar to FIG. 5 showing a similar relationship between the parts of a container according to a slightly different embodiment of the invention.

FIG. 7 is a view in perspective of a container according to this invention with the cap removed, and before the closure portion has been completely inserted therein.

FIG. 8 is a similar perspective view of the container of FIG. 7 after the closure portion has been inserted and after the lid portions have been folded down into the container.

FIG. 9 is a plan view of the closure portion taken from the top side of the lid portions before folding.

Referring to the drawings, there is shown a bicameral container in the form of a cylindrical cup. The container comprises a bottom section 11, a side wall 12 extending upwardly from the perimeter of the bottom section all around the container, a cap 13 which snaps on to the top of the container and a closure portion 14 which divides the container into two compartments 15 and 16 and provides inner lid portions 17 for each of the compartments. The side wall 12 forms a cylinder which is tapered slightly inwardly toward the bottom of the container. The container bottom is closed by the bottom section 11 thereof which is in the form of a disc which fits into the lower end of the cylinder formed by the side wall on top of an upturned annular ring 18 integral with the side wall along its bottom edge. The bottom section 11 is dished upwardly slightly prior to insertion of the closure portion 14 for reasons which will be described more fully hereinafter.

The side wall 12 is turned over along its top edge to form a bead 19 extending around the top edge of the container and has an annular recess 21 facing the inside of the container and extending around the container spaced below its top edge.

The cap has a turned flange portion 22 which fits over the bead 19 around the top edge of the side wall and a depressed portion 23 which fits into the annular recess 21 in the side wall to provide a snap fit between the cap 13 and the wall 12 when the cap is in position on the top of the container. The depressed portion 23 of the cap has a depending wall portion 24 which is inclined downwardly and outwardly as it approaches the annular recess and the respective dimensions of the cap 13 and side wall 12 are such that the outer diameter of the lower end of the depending wall 24 of the cap is slightly greater than the inner diameter of the side wall just above the annular recess 21. The inclined wall portion 24 of the cap is snapped into the annular recess 21 by temporarily distending the side wall above the recess as the cap is pressed into position. The cap structure is completed by a horizontal cover portion 25 connected to the bottom edge of the inclined depending wall 24 and extending across the top end of the cylinder formed by the side wall 12 to close off the top of the container.

The closure member 14 is folded to form a relatively stiff, vertical divider portion 26 and opposed lid portions 17 extending horizontally in opposite directions from the top of the divider portion. As shown in FIGS. 2-5, the dimensions of the divider portion 26 are such that when the divider is held vertically and pressed downwardly into the container, its side edges exert positive pressure against the side wall 12 of the container all along the edges of the divider portion when the divider is in contact with, and exerting positive pressure on, the bottom section 11 along the line of contact between them. As shown in FIGS. 3 and 4, the straight bottom edge of the divider 26 will straighten the dish in the bottom section 11 when the divider is pressed downwardly. This will tend to effect and maintain a tight fit between the divider 26 and the bottom section 11. The closure member 14 is slit along the bottom fold of the divider portion 26 for a

slight distance inwardly from each of the edges of the closure member so that downwardly extending nibs 26c are provided on each end of the bottom edge of the divider portion when the closure member is folded. These nibs 26c facilitate fitting of the divider portion with the circumferential edge portion of the dished bottom section 11. Since the cylinder formed by the side wall 12 is tapered slightly, the side edges of the divider portion 26 also have a corresponding taper, as shown most clearly in FIG. 4 to provide the desired fit.

When the divider portion 26 is in position in the container, as shown in FIGS. 2-5, two compartments 15 and 16 are provided, one on each side of the divider. The lid portions 17 are folded downwardly into the container so that they may be pressed into contact with the bottom of the annular recess 21 to seal off the tops of their respective compartments.

Referring in particular to FIG. 5, in the embodiments of FIGS. 1-5, the dimensions of the cap 13 and the closure member 14 and the shape and location of the annular recess 21 in the side wall 12 are such that a flat sheet or a laminate thereof 27, such as might be formed by an instruction leaflet or a folded piece of sand paper, is intended to be located between the cover portion 25 of the cap and the folded over lid portions 17 of the closure member. When the cap 13 is snapped into position on the top of the container, with the lower edge of its inclined wall portion 24 fitting into the annular recess 21 in the side wall, the cap, through the inserted sheet material 27, presses downwardly upon the top of the divider portion 26 and the lid portions 17 of the closure member with sufficient force to cause the divider portion to fit with the bottom section 11 and opposite portions of the side wall 12 and exert positive pressure thereon along the edges of the divider portion 26. At the same time, the lid portions 17 of the closure member are caused to press downwardly upon the bottom of the annular recess 21 to effect a seal with the recess. The lid portions 17 also fix the position of the top of the divider portion 26 so that the divider portion will not be displaced or pushed over through forces applied by the cap or through handling.

In the embodiment of FIG. 6, the respective dimensions of the cap 13, the closure member 14 and the recess 21 in the side wall are such that this same relationship occurs in the absence of inserted sheet material. In other words, the bottom of the cover portion 25 of the cap, itself, presses downwardly upon and contacts the divider portion 26 and the lid portions 17 of the closure member to effectively seal off the two compartments formed thereby. Provision may be made for the presence or absence of inserted sheet material 27 by varying the dimensions of the cap, the closure member or the annular recess, or various combinations of these.

As shown most clearly in FIGS. 7 and 9, the closure member 14 is an integral, or one-piece, unit which may be cut or stamped from a sheet of strip material in the shape which will provide the desired dimensions for the divider portion 26 and the lid portions 17 of the closure member when it is folded. The divider portion 26 conveniently is of double thickness and formed by folding and slitting the sheet along the fold line A—A and superimposing those portions 26a and 26b on each side of the fold. The slits extend for a slight distance inwardly from each of the edges of the closure member to form the nibs 26c when the closure member is folded. Tabs 28 are provided at each end of the closure member for easy removal of the unit from the container and fold lines B—B are provided in addition to the fold line A—A for rapid folding to the desired shape.

As shown in FIG. 7, the closure member 14 is first folded about the center fold line A—A to provide a vertical divider 26 which is higher than the side wall 12 of the container. This divider then is inserted in the container to divide it into two compartments. The lid por-

tions 17 may be left upstanding during the filling of one or both of the compartments to add height to the divider and prevent overflowing or spillage into the wrong compartment. One compartment may be filled at a time and closed by folding the lid portion 17 on one side downwardly and then both lid portions may be folded downwardly into position in the annular recess 21, as shown in FIGS. 2, 3 and 8. As shown in FIG. 3, one compartment may contain a solid material S and the other a liquid L, or a semi-solid and a liquid, or two solids, or any other conceivable combination of materials which should be kept separate during shipment and storage but intermixed before, or during, use.

The various parts of the container of this invention may be formed of any material which is sufficiently stiff or rigid to allow the parts to be fitted together and exert positive pressure upon one another as described hereinbefore to effectively seal off the two compartments. For instance, the side wall 12, bottom section 11, and cap structure 13 of the container may be of the well-known type manufactured by the Dixie Cup Division of The American Can Company and may comprise a cardboard side wall and bottom section and a metal or cardboard cap. Preferably, the closure member 14 is formed from a sheet of relatively heavy cardboard which is scored along the fold lines A—A and B—B, as shown in FIG. 9. When the side wall 12 and bottom section 11 of the container and the closure portion 14 is formed from cardboard, it normally is necessary to coat the inner surfaces of each of these parts with polyethylene, polypropylene, polyvinylchloride, or a similar material to provide resistance to moisture and assure that the parts are impermeable to the materials packaged in the compartments of the container.

When the container of this invention is utilized to package an epoxy resin and hardener, it has been discovered that superior results can be obtained when all the interior surfaces of the side wall 12 and the bottom section 11 of the container are coated with a layer of an epoxy resin prior to filling the container. This can be accomplished by spraying the surfaces of these parts with a solution of an epoxy resin and hardener in sufficient thickness to provide an impermeable and non-toxic barrier layer thereon. Epoxy coated containers of this type have been found to be highly advantageous for packaging any material which tends to penetrate the cardboard walls of the container.

While the container described above generally is suitable for storing various materials including certain liquids, the press-fit relationship between the closure portion 14 and the other parts of the container is not normally adequate to separate liquids having a low viscosity. However, if it is desired to package one or more of such liquids in this container, the edge of the closure portion 14 may be coated with a bead, not shown, of butyl rubber or some similar adhesive or semi-adhesive material which could provide a positive seal between the edges of the closure portion and the respective portions of the side wall and the bottom section of the container when the parts are caused to exert positive pressure upon one another as described above to provide fluid tight compartments.

Having now described the invention in specific detail and exemplified the manner in which it may be carried into practice, it will be readily apparent to those skilled in the art that innumerable variations, modifications, applications, and extensions of the basic principles involved may be made without departing from its spirit and scope.

The claims are:

1. A bicameral container comprising a bottom section, a side wall extending upwardly from the perimeter of the bottom section and extending around the container, a snap-on cap adapted to fit on the top of said side wall, said side wall having an annular recess extending around

5

the container and spaced below the top edge of said side wall, a folded closure member comprising a relatively stiff vertical divider portion and opposed lid portions each being connected to the divider portion and adapted to extend horizontally in opposite directions from the top of the divider portion, said closure member being formed by making three folds only in a single sheet of material, said divider portion comprising two thicknesses and each of said lid portions comprising one thickness of said sheet material and said divider portion and lid portions thereof being integral, one of said folds extending across the bottom of said divider portion and holding the two thicknesses of the divider portion together at both sides of the divider portion, and means associated with said cap for pressing said closure downwardly when said cap is fitted on the top edge of said side wall, said divider portion being adapted to fit with the bottom section and opposite portions of the side wall of said container and exert positive pressure thereon along the edges of the divider portion, and the edges of said lid portions being adapted to press downwardly upon the bottom of the annular recess thereby effecting a seal with said recess, when said cap is fitted on the top edge of said side wall.

2. A bicameral container comprising a bottom section, a side wall extending upwardly from the perimeter of the bottom section and extending around the container, a snap-on cap adapted to fit on the top of said side wall, said side wall having an annular recess extending around the container and spaced below the top edge of said side wall, a folded closure member comprising a relatively stiff vertical divider portion and opposed lid portions each being connected to the divider portion and adapted to extend horizontally in opposite directions from the top of the divider portions, said closure member being formed by making three folds only in a single sheet of material, said divider portion comprising two thicknesses and each of said lid portions comprising one thickness of said

6

sheet material and said divider portion and lid portions thereof being integral, one of said folds extending across the bottom of said divider portion and holding the two thicknesses of the divider portion together at both sides of the divider portion, said cap having a depressed portion for pressing said closure downwardly when said cap is fitted on the top edge of said side wall, said divider portion being adapted to fit with the bottom section and opposite portions of the side wall of said container and exert positive pressure thereon along the edges of the divider portion, and the edges of said lid portions being adapted to press downwardly upon the bottom of the annular recess thereby effecting a seal with said recess, when said cap is fitted on the top edge of said side wall.

3. A bicameral container according to claim 2, wherein the depressed portion of said cap is adapted to fit into the annular recess in said wall when the cap is positioned on the top of the wall.

4. A bicameral container according to claim 1, wherein said side wall is in the form of a closed cylinder tapered inwardly slightly toward the bottom of the container and the side edges of said divider portion are correspondingly tapered.

5. A bicameral container according to claim 1, wherein said closure member is formed by folding a single sheet of material and the divider portion and the lid portions thereof are integral and wherein the divider portion has a bottom edge formed by a fold in the closure member and said bottom edge has a nib at each end extending slightly downwardly.

References Cited in the file of this patent

UNITED STATES PATENTS

2,335,016	Lorenzen et al. -----	Nov. 23, 1943
2,661,870	Huenergardt -----	Dec. 8, 1953
2,707,588	Amberg -----	May 3, 1955
2,740,575	Fontaine -----	Apr. 3, 1956