



(19) **United States**

(12) **Patent Application Publication**
Gardner

(10) **Pub. No.: US 2001/0030591 A1**

(43) **Pub. Date: Oct. 18, 2001**

(54) **INTEGRATED INDUCTOR**

Related U.S. Application Data

(63) Continuation-in-part of application No. 09/444,608, filed on Nov. 23, 1999.

(76) Inventor: **Donald S. Gardner**, Mountain View, CA (US)

Publication Classification

Correspondence Address:

BLAKELY SOKOLOFF TAYLOR & ZAFMAN
12400 WILSHIRE BOULEVARD, SEVENTH FLOOR
LOS ANGELES, CA 90025 (US)

(51) **Int. Cl.⁷ H01F 5/00**

(52) **U.S. Cl. 336/200**

(57) **ABSTRACT**

An inductor comprises a substrate comprising a semiconductor material, a first dielectric layer over the substrate, a magnetic layer over the first dielectric layer, a second dielectric layer over the magnetic layer, and a conductor over the second dielectric layer.

(21) Appl. No.: **09/766,162**

(22) Filed: **Jan. 19, 2001**

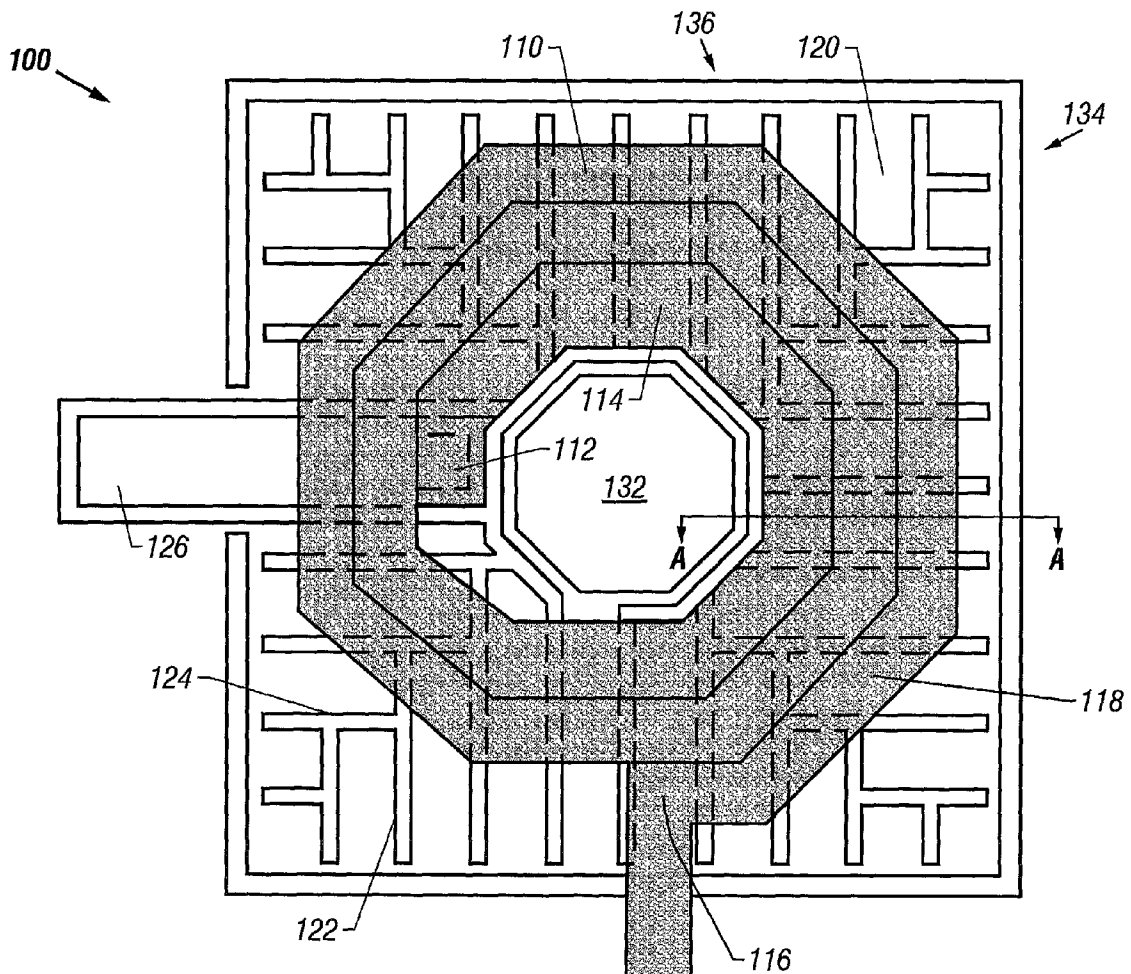

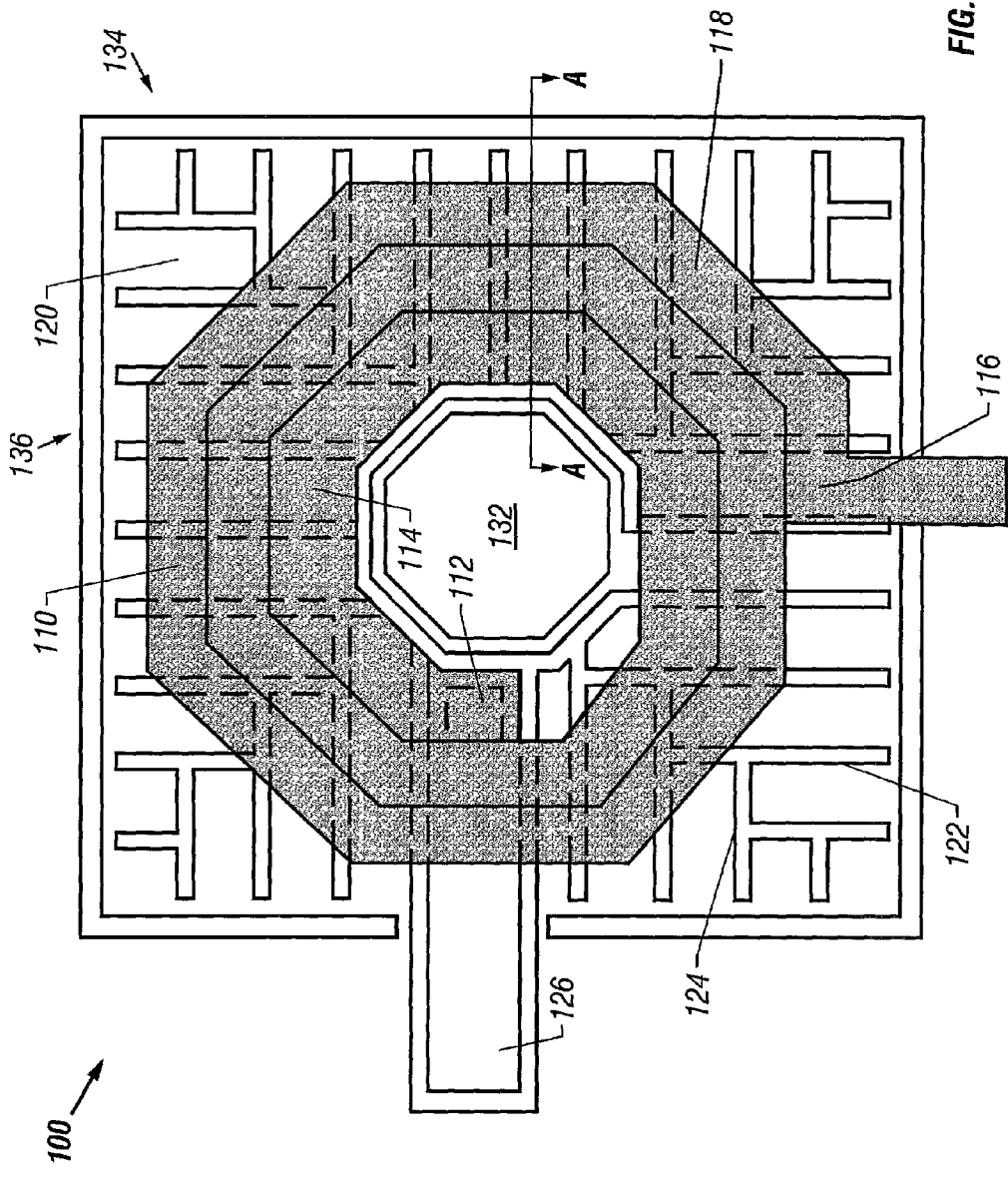

FIG. 1

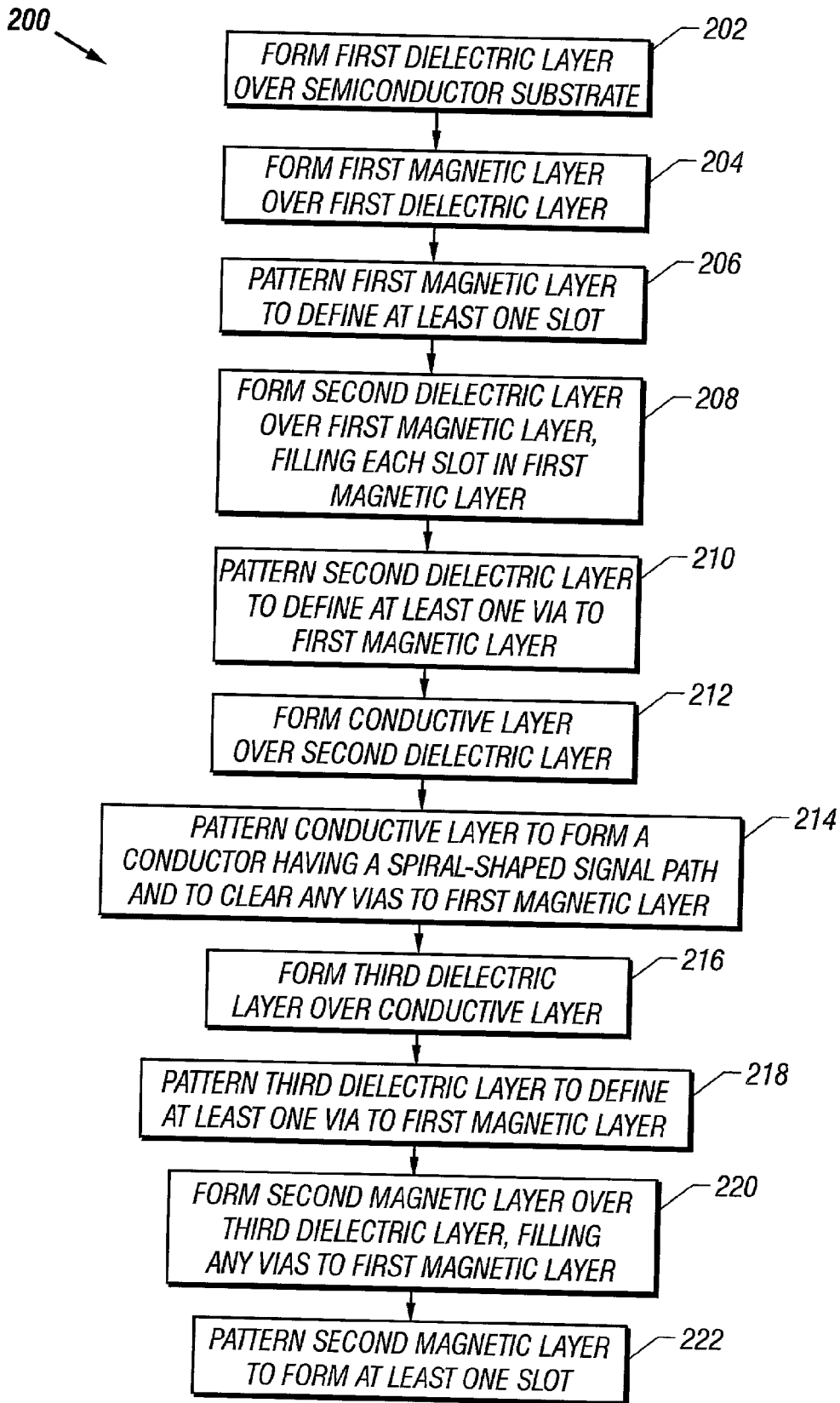

FIG. 2

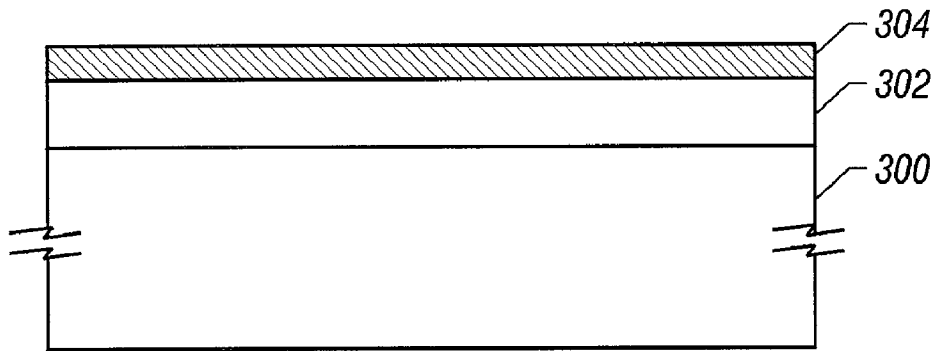

FIG. 3

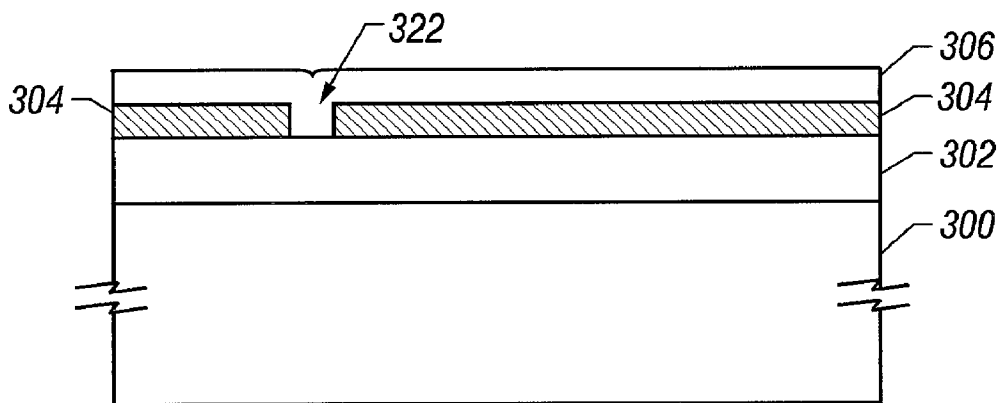

FIG. 4

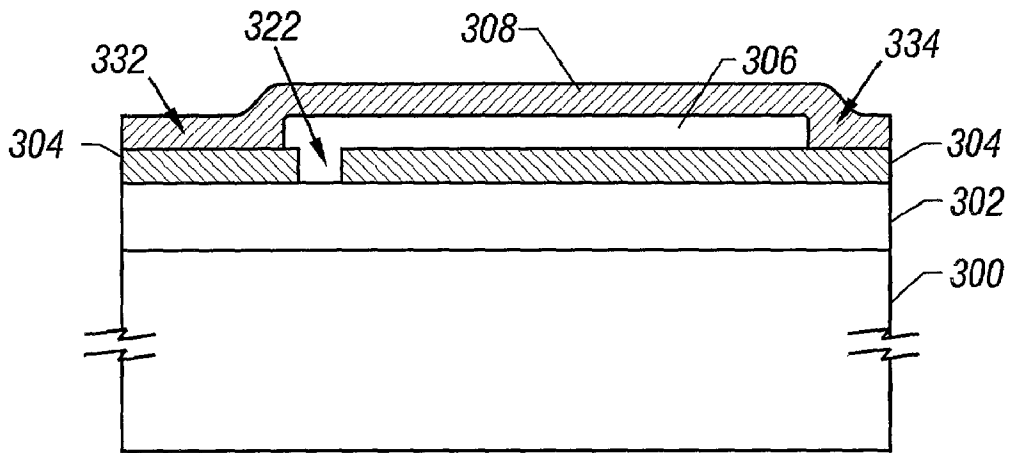

FIG. 5

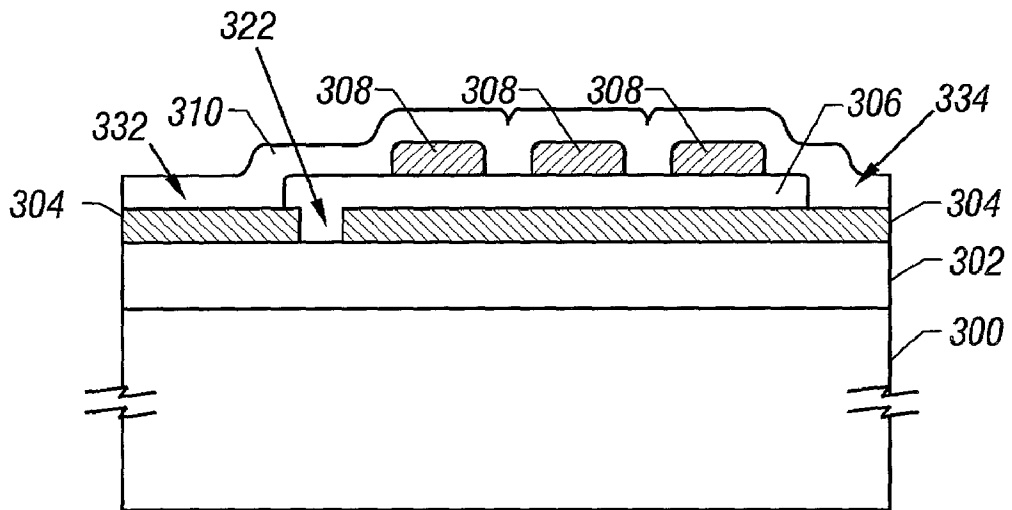

FIG. 6

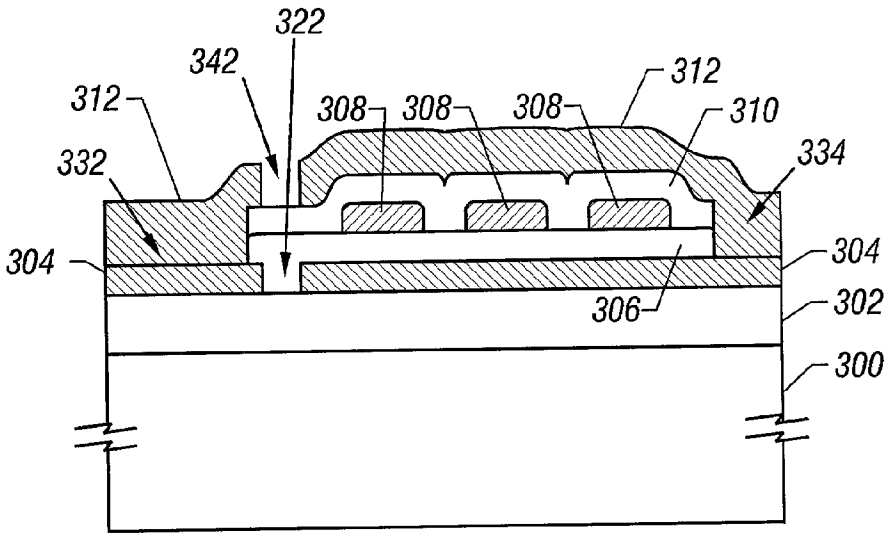

FIG. 7

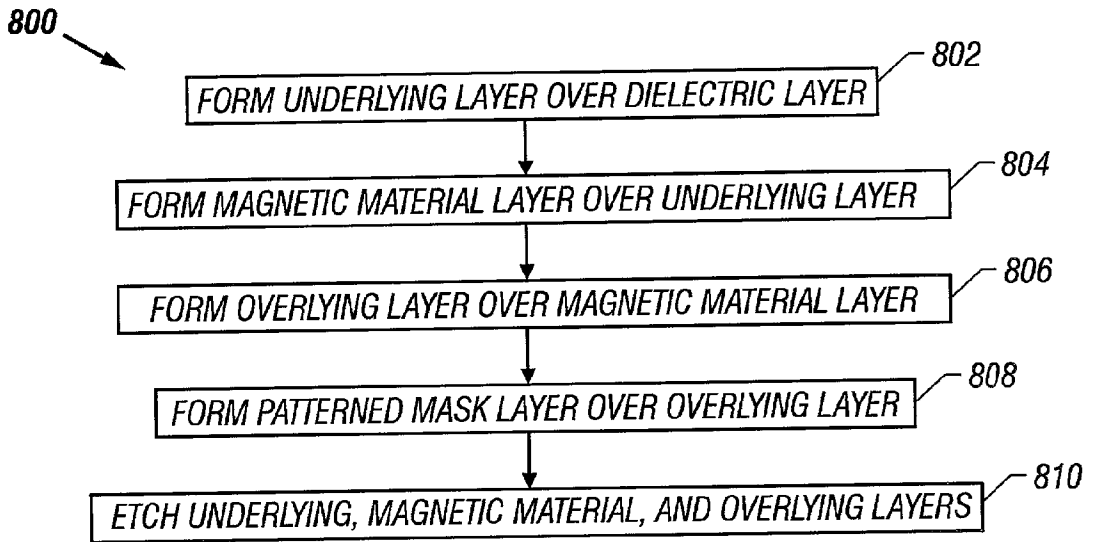

FIG. 8

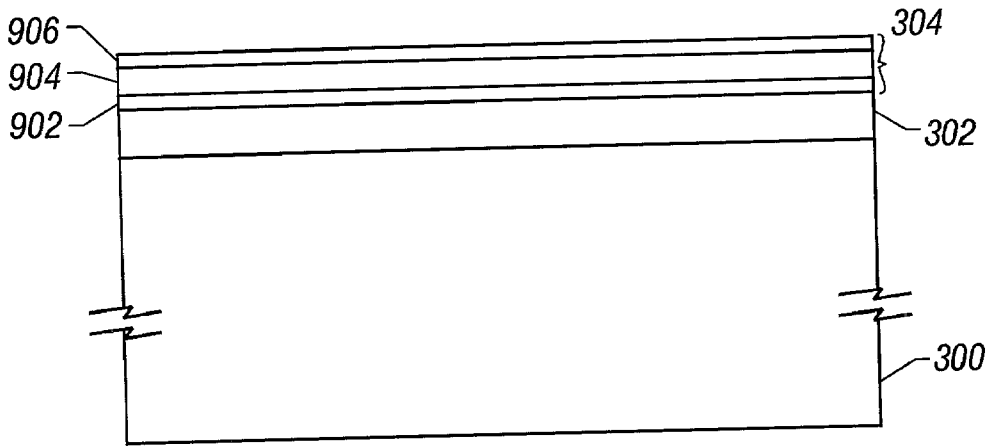

FIG. 9

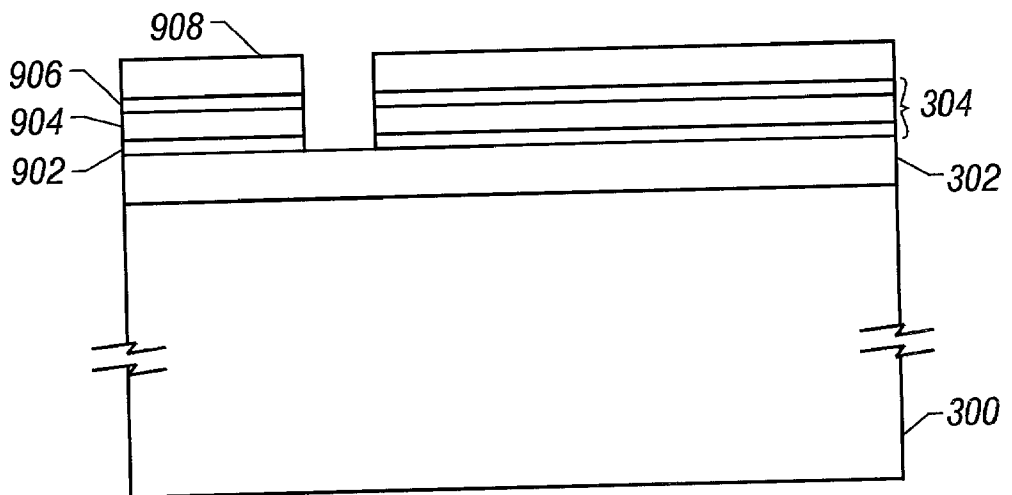

FIG. 10

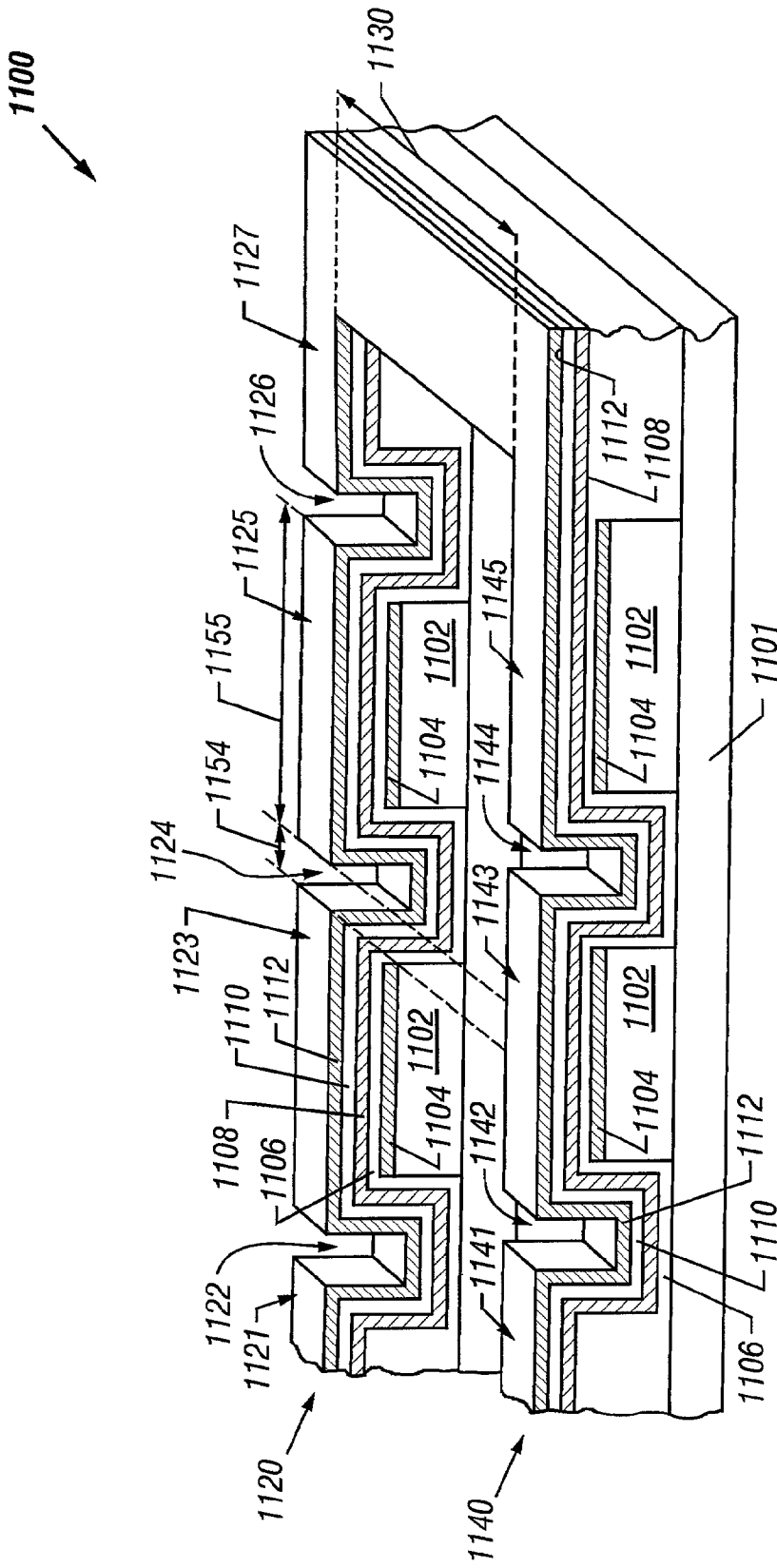

FIG. 11

1200 ↘

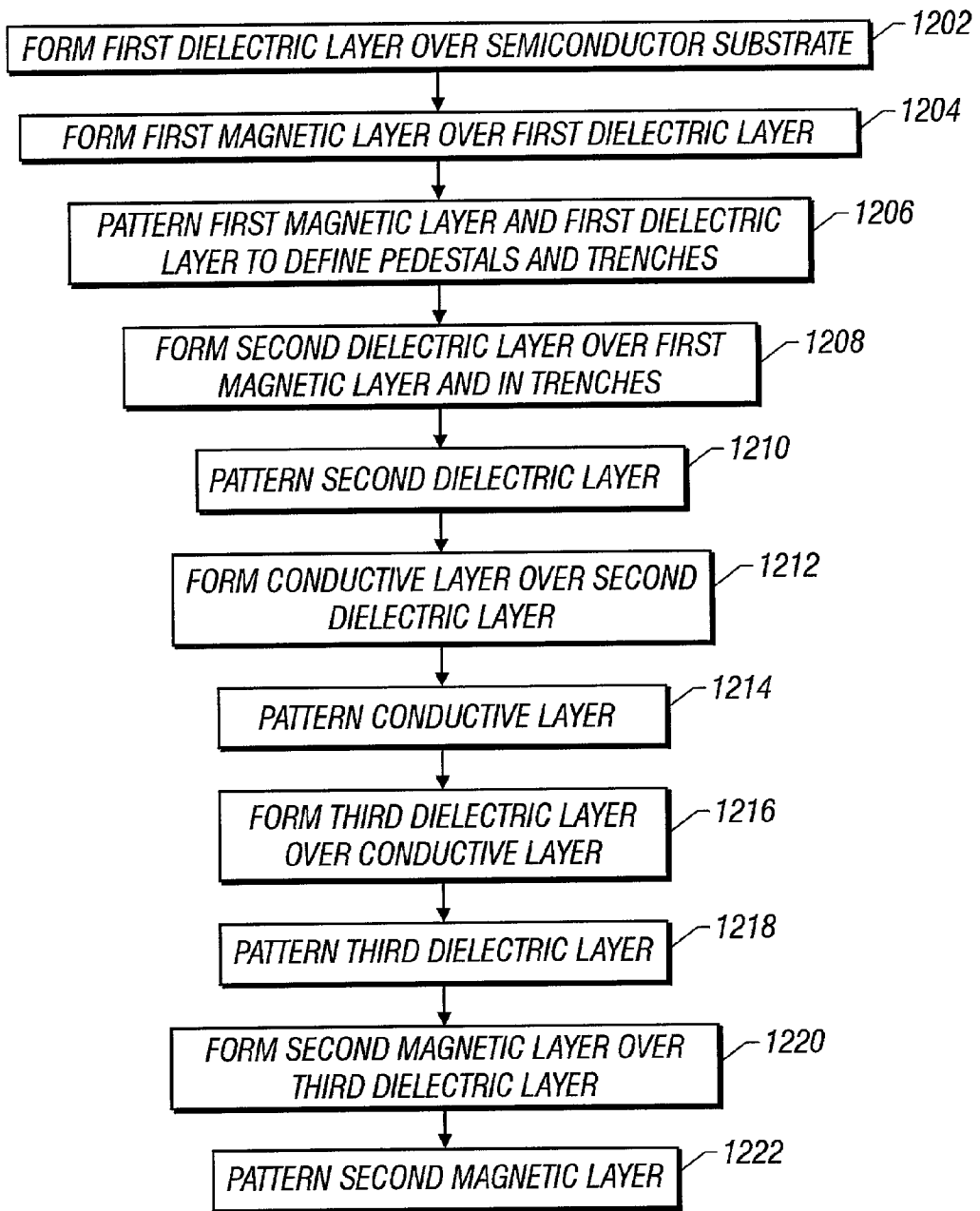

FIG. 12

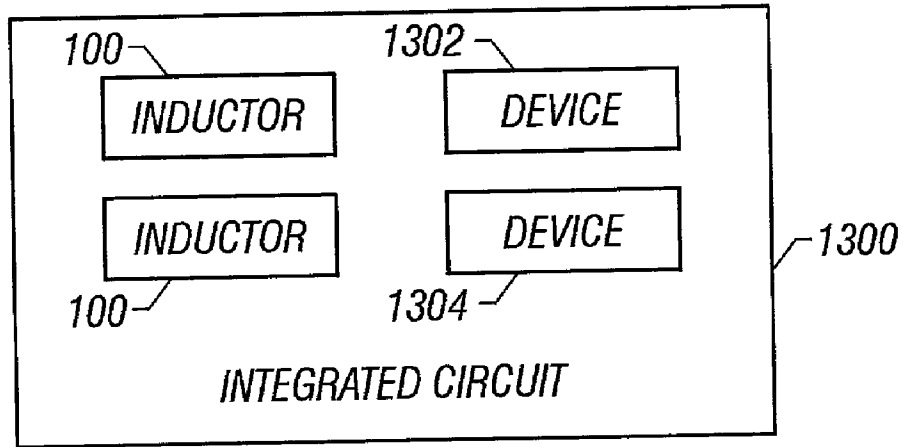

FIG. 13

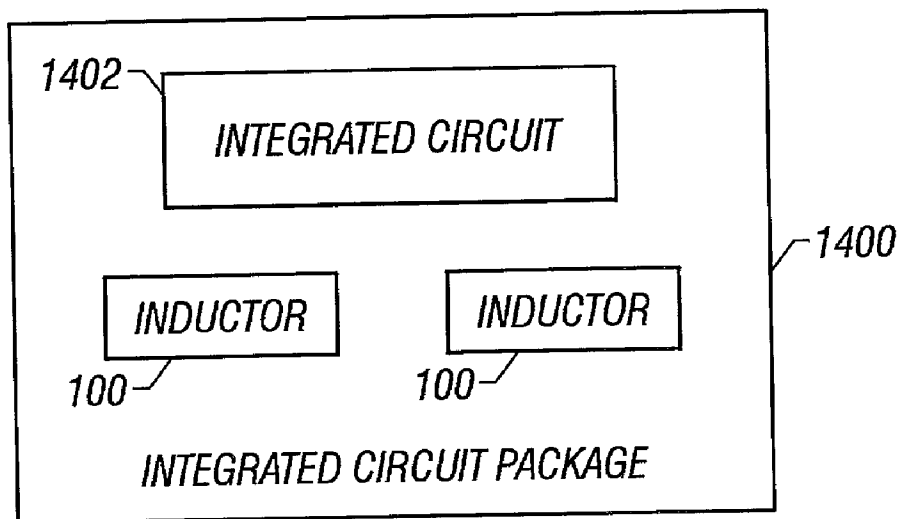

FIG. 14

INTEGRATED INDUCTOR

[0001] This patent application is a continuation-in-part patent application of U.S. patent application Ser. No. 09/444,608, filed Nov. 23, 1999, entitled METHOD AND APPARATUS FOR PROVIDING INDUCTOR FOR INTEGRATED CIRCUIT OR INTEGRATED CIRCUIT PACKAGE, by Donald S. Gardner.

BACKGROUND OF THE INVENTION

[0002] 1. Field of the Invention

[0003] The present invention relates generally to the field of electrical inductors. More particularly, the present invention relates to the field of electrical inductors for integrated circuits (ICs) and IC packages.

[0004] 2. Description of Related Art

[0005] Electrical inductors are typically used in a variety of microelectronic circuit applications such as, for example, transformers, power converters, electromagnetic interference (EMI) noise reduction, and radio frequency (RF) and microwave circuitry including oscillators, amplifiers, and matching networks. Because discrete inductive devices result in losses, for example, due to parasitic capacitance and resistance in connecting them to an integrated circuit and because discrete inductive devices incur a relatively high cost for assembly, inductors are preferably fabricated on-chip, that is either integrated on an integrated circuit and/or in a package housing an integrated circuit. Such integrated inductors are designed, to the extent possible, to have a relatively high frequency range and a desirable quality factor $Q=\omega L/R$, where ω is the operating frequency for the inductor, L is the inductance of the inductor, and R is the resistance of the inductor.

BRIEF DESCRIPTION OF THE DRAWINGS

[0006] The present invention is illustrated by way of example and not limitation in the figures of the accompanying drawings, in which like references indicate similar elements and in which:

[0007] FIG. 1 illustrates, for one embodiment, a plan view of an integrated inductor;

[0008] FIG. 2 illustrates, for one embodiment, a flow diagram to form the integrated inductor of FIG. 1;

[0009] FIG. 3 illustrates, for one embodiment, a cross-sectional view of a substrate over which a first dielectric layer and a magnetic layer are formed;

[0010] FIG. 4 illustrates, for one embodiment, a cross-sectional view of the substrate of FIG. 3 after the first magnetic layer has been patterned and a second dielectric layer has been formed;

[0011] FIG. 5 illustrates, for one embodiment, a cross-sectional view of the substrate of FIG. 4 after the second dielectric layer has been patterned and a conductive layer has been formed;

[0012] FIG. 6 illustrates, for one embodiment, a cross-sectional view of the substrate of FIG. 5 after the conductive layer has been patterned and a third dielectric layer has been formed;

[0013] FIG. 7 illustrates, for one embodiment, a cross-sectional view of the substrate of FIG. 6 after the third dielectric layer has been patterned and a second magnetic layer has been formed and patterned;

[0014] FIG. 8 illustrates, for one embodiment, a flow diagram to form a magnetic layer;

[0015] FIG. 9 illustrates, for one embodiment, a cross-sectional view of a substrate over which a dielectric layer and a magnetic layer have been formed;

[0016] FIG. 10 illustrates, for one embodiment, a cross-sectional view of the substrate of FIG. 9 after a patterned mask layer has been formed and the magnetic layer has been patterned;

[0017] FIG. 11 illustrates, for one embodiment, a perspective view of another integrated inductor;

[0018] FIG. 12 illustrates, for one embodiment, a flow diagram to form the integrated inductor of FIG. 11;

[0019] FIG. 13 illustrates, for one embodiment, a block diagram of an integrated circuit comprising one or more inductors; and

[0020] FIG. 14 illustrates, for one embodiment, a block diagram of an integrated circuit package comprising one or more inductors.

DETAILED DESCRIPTION

[0021] The following detailed description sets forth an embodiment or embodiments in accordance with the present invention for an integrated inductor. In the following description, details are set forth such as specific materials, parameters, etc. in order to provide a thorough understanding of the present invention. It will be evident, however, that the present invention may be practiced without these details. In other instances, well-known process steps, equipment, etc. have not been described in particular detail so as not to obscure the present invention.

[0022] Spiral Inductor Structure

[0023] FIG. 1 illustrates, for one embodiment, an integrated inductor 100. Integrated inductor 100 comprises a generally spiral-shaped conductor 110 defining a signal path along which current may flow to generate an electromagnetic field around conductor 110. Current may be induced to flow through conductor 110 by applying a voltage potential across an innermost node 112 near the beginning of an innermost turn 114 of conductor 110 and an outermost node 116 near the end of an outermost turn 118 of conductor 110.

[0024] Although illustrated as defining approximately 2/4 generally octagonal-shaped turns, conductor 110 may define any suitable number of one or more turns and any suitable fraction of a turn of any suitable shape. Each turn may be rectangular or circular in shape, for example. Conductor 110 may comprise any suitable conductive material and may have any suitable dimensions. The signal path defined by conductor 110 may have any suitable width, thickness, and length with any suitable spacing between turns to form a generally spiral-shaped conductor 110 covering an area of any suitable shape and size. As used in this description, a spiral or spiral-shaped conductor includes any conductor defining a signal path having at least one turn with each

successive turn, if any, substantially surrounding the innermost turn and any preceding turn.

[0025] Inductor **100** for one embodiment comprises a magnetic layer **120**. Conductor **110** is positioned over magnetic layer **120** and is separated from magnetic layer **120** by at least a dielectric layer. Such a dielectric layer may comprise any suitable dielectric material and have any suitable thickness. The dielectric material and thickness help determine the capacitance and therefore the resonance frequency ω_r for inductor **100**. Magnetic layer **120** forms a voltage reference plane for inductor **100** to help contain electric and magnetic fields around conductor **110**. Magnetic layer **120** therefore helps increase the inductance L of inductor **100**, and therefore the quality factor Q for inductor **100**. Magnetic layer **120** may comprise any suitable magnetic material and have any suitable shape, such as the rectangular shape illustrated in **FIG. 1** for example, and any suitable dimensions.

[0026] As the quality factor Q of inductor **100** is proportional to the inductance L of inductor **100** and inversely proportional to the resistance R of inductor **100**, inductor **100** can be designed with a relatively higher inductance L , and therefore a relatively higher quality factor Q , for a given area or resistance R of inductor **100**. Alternatively, for a given inductance L , inductor **100** can be designed with a relatively smaller area and therefore a relatively lower resistance R and capacitance, resulting in a relatively higher resonance frequency ω_r and a relatively higher quality factor Q .

[0027] Inductor **100** for one embodiment is formed over a substrate comprising a semiconductor material with at least a dielectric layer separating magnetic layer **120** from the substrate. Such a dielectric layer may comprise any suitable dielectric material and have any suitable thickness. As conductor **110** generates a magnetic flux toward the substrate that would induce Eddy or mirror currents and therefore noise in the substrate, positioning magnetic layer **120** between the substrate and conductor **110** helps reduce such currents and therefore allows inductor **100** to be formed over integrated circuit devices with minimized concern for interference. Magnetic layer **120** also helps prevent substrate coupling and helps reduce substrate dependency.

[0028] Magnetic layer **120** for one embodiment defines slots, such as slots **122** and **124** for example, to help further reduce any Eddy currents in the substrate. Magnetic layer **120** may define any suitable number of one or more slots with any suitable dimensions and orientation at any suitable one or more locations relative to conductor **110**. One or more slots may be perpendicular to or at any other suitable angle relative to the flow of current through conductor **110**. Defining slots in magnetic layer **120** also reduces Eddy currents that can form in magnetic layer **120** and helps to increase the resonance frequency ω_r for inductor **100**.

[0029] Magnetic layer **120** for one embodiment has a relatively high magnetic permeability and a relatively high saturation magnetization to allow inductor **100** to operate at relatively high frequencies, such as in the gigaHertz (GHz) for example, and therefore realize a relatively high quality factor Q for inductor **100**. Permeability is a measure of the ability of a magnetic material to magnetize. A non-magnetic material has a relative permeability of one. A magnetic material having a relatively high saturation magnetization allows for relatively high currents to be used.

[0030] Magnetic layer **120** for one embodiment is compatible with available semiconductor processing and packaging technology that may be used to form a chip having inductor **100**. That is, magnetic layer **120** may be formed and optionally patterned using available semiconductor processing technology and may generally withstand relatively high temperatures encountered in processing and packaging a chip on which inductor **100** is formed without crystallizing or significantly changing the relevant properties of magnetic layer **120**.

[0031] Magnetic layer **120** for one embodiment comprises cobalt (Co). Magnetic layer **120** for one embodiment comprises an amorphous cobalt (Co) alloy comprising cobalt (Co) and any suitable one or more elements of any suitable atomic or weight percentage. The amorphous cobalt (Co) alloy may have any suitable atomic order. For one embodiment, the amorphous cobalt (Co) alloy has an atomic order in the range of approximately 1 angstrom (\AA) to approximately 100 angstroms (\AA). For one embodiment, the amorphous cobalt (Co) alloy has an atomic order in the range of approximately 1 angstrom (\AA) to approximately 25 angstroms (\AA). For one embodiment, the amorphous cobalt (Co) alloy has an atomic order in the range of approximately 1 angstrom (\AA) to approximately 10 angstroms (\AA).

[0032] Magnetic layer **120** for one embodiment comprises an amorphous cobalt (Co) alloy comprising cobalt (Co) and zirconium (Zr). Zirconium (Zr) helps make cobalt (Co) amorphous. Magnetic layer **120** for one embodiment comprises a cobalt-zirconium (CoZr) alloy having one or more additional elements, such as tantalum (Ta) and niobium (Nb) for example, that help make the cobalt-zirconium (CoZr) alloy magnetically softer. Magnetic layer **120** for one embodiment comprises a cobalt-zirconium (CoZr) alloy having one or more additional elements, such as a rare earth element for example, that help increase the ferromagnetic resonance of the cobalt-zirconium (CoZr) alloy. Rare earth elements include rhenium (Re), neodymium (Nd), praseodymium (Pr), and dysprosium (Dy) for example. Rhenium (Re) help reduce stress and magnetostriction for the cobalt-zirconium (CoZr) alloy.

[0033] Where magnetic layer **120** comprises a cobalt-zirconium (CoZr) alloy, magnetic layer **120** may comprise, for example, approximately 3 atomic percent to approximately 10 atomic percent zirconium (Zr).

[0034] Where magnetic layer **120** comprises a cobalt-zirconium-tantalum (CoZrTa) alloy, magnetic layer **120** may comprise, for example, approximately 3 atomic percent to approximately 10 atomic percent zirconium (Zr) and may comprise up to and including approximately 10 atomic percent tantalum (Ta). Magnetic layer **120** for one embodiment comprises approximately 91.5 atomic percent cobalt (Co), approximately 4 atomic percent zirconium (Zr), and approximately 4.5 atomic percent tantalum (Ta). Such a CoZrTa alloy can operate in the gigaHertz range and can withstand temperatures up to approximately 450° Celsius without crystallizing or significantly changing its relevant properties.

[0035] Where magnetic layer **120** comprises a cobalt-zirconium-rhenium (CoZrRe) alloy, magnetic layer **120** may comprise, for example, approximately 3 atomic percent to approximately 10 atomic percent zirconium (Zr) and may comprise up to and including approximately 3 atomic per-

cent rhenium (Re). Magnetic layer **120** for one embodiment comprises approximately 89 atomic percent cobalt (Co), approximately 8 atomic percent zirconium (Zr), and approximately 3 atomic percent rhenium (Re).

[0036] Magnetic layer **120** may have any suitable thickness. Magnetic layer **120** for one embodiment has a thickness in the range of approximately 0.05 microns (μm) to approximately 2.0 microns (μm). Magnetic layer **120** for one embodiment has a thickness in the range of approximately 0.2 microns (μm) to approximately 1.0 micron (μm). Magnetic layer **120** for one embodiment has a thickness of approximately 0.4 microns (μm).

[0037] Inductor **100** for one embodiment comprises another magnetic layer positioned over conductor **110** and separated from conductor **110** by at least a dielectric layer. Such a dielectric layer may comprise any suitable dielectric material and have any suitable thickness. The dielectric material and thickness help determine the capacitance and therefore the resonance frequency ω_r of inductor **100**. The other magnetic layer may comprise any suitable magnetic material and have any suitable shape and dimensions similarly as for magnetic layer **120**. The other magnetic layer may or may not comprise the same magnetic material as magnetic layer **120**. The other magnetic layer helps further increase the inductance L of inductor **100**, and therefore the quality factor Q for inductor **100**, when used with magnetic layer **120**.

[0038] The other magnetic layer for one embodiment defines slots to help reduce Eddy currents and increase the resonance frequency ω_r for inductor **100**. The other magnetic layer may define any suitable number of one or more slots with any suitable dimensions and orientation at any suitable one or more locations relative to conductor **110**. One or more slots may be perpendicular to or at any other suitable angle relative to the flow of current through conductor **110**.

[0039] Inductor **100** may optionally comprise both magnetic layer **120** and the other magnetic layer or only either one of the two magnetic layers. For one embodiment where inductor **100** comprises both magnetic layer **120** and the other magnetic layer, magnetic layer **120** and the other magnetic layer may be connected through a region **132** within innermost turn **114** of conductor **110** and/or at one or more regions, such as regions **134** and **136** for example, along a perimeter surrounding outermost turn **118** of conductor **110**. Connecting magnetic layer **120** and the other magnetic layer helps increase the inductance L of inductor **100** and therefore the quality factor Q for inductor **100**. Magnetic layer **120** and the other magnetic layer may be connected along a perimeter of any suitable shape, such as the rectangular shape illustrated in **FIG. 1** for example. Connecting magnetic layer **120** and the other magnetic layer at most or substantially all regions along a perimeter surrounding conductor **110** helps prevent straying of the magnetic flux generated by conductor **110**.

[0040] Spiral Inductor Fabrication

[0041] Inductor **100** may be fabricated in any suitable manner. For one embodiment, inductor **100** is fabricated in accordance with flow diagram **200** as illustrated in **FIG. 2**.

[0042] For block **202** of **FIG. 2**, a first dielectric layer **302** is formed over a substrate **300** as illustrated in **FIG. 3**. The cross-sectional view of **FIG. 3** generally corresponds a

cross-section at line A-A of inductor **100** as illustrated in **FIG. 1**. Substrate **300** may comprise any suitable semiconductor material, such as silicon (Si), germanium (Ge), or gallium arsenide (GaAs) for example. Dielectric layer **302** may comprise any suitable dielectric material, such as an oxide of silicon for example, and may be formed to any suitable thickness using any suitable technique. Dielectric layer **302** helps insulate inductor **100** from substrate **300**. For one embodiment, dielectric layer **302** is formed by depositing silicon dioxide (SiO_2) over substrate **300** to a thickness of approximately 2 microns (μm) using a suitable chemical vapor deposition (CVD) technique. For another embodiment where substrate **300** comprises silicon (Si), dielectric layer **302** may be formed by growing approximately 2 microns (μm) of silicon dioxide (SiO_2) on substrate **300**.

[0043] Although illustrated in **FIG. 3** as forming dielectric layer **302** directly over substrate **300**, dielectric layer **302** may be formed over one or more suitable layers, such as one or more interconnect, via, dielectric, and/or device layers for example, formed over substrate **300**.

[0044] For block **204**, a magnetic layer **304** is formed over dielectric layer **302** as illustrated in **FIG. 3**. Magnetic layer **304** corresponds to magnetic layer **120** of **FIG. 1**. Magnetic layer **304** may comprise any suitable magnetic material and may be formed to any suitable thickness using any suitable technique. For one embodiment, magnetic layer **304** is formed by sputter depositing an amorphous cobalt (Co) alloy, such as a suitable cobalt-zirconium-tantalum (CoZrTa) alloy for example, to a thickness in the range of approximately 0.2 microns (μm) to approximately 1.0 micron (μm) over dielectric layer **302**. The magnetic material for one embodiment for magnetic layer **304** may be deposited in the presence of an applied magnetic field to induce desirable magnetic properties in magnetic layer **304**.

[0045] For block **206**, magnetic layer **304** is patterned to define at least one slot, such as slot **322** for example, as illustrated in **FIG. 4**. Magnetic layer **304** may be patterned to define any suitable number of one or more slots with any suitable dimensions and orientation at any suitable one or more locations. Magnetic layer **304** for one embodiment is patterned to define slots having a width in the range of approximately 0.05 microns (μm) to approximately 15 microns (μm). Magnetic layer **304** for one embodiment is patterned to define a conductive underpass **126** to innermost node **112** of inductor **110** as illustrated in **FIG. 1** to allow a voltage potential to be applied to node **112**.

[0046] Magnetic layer **304** may be patterned using any suitable patterning technique. Magnetic layer **304** for one embodiment is patterned by forming a patterned mask over magnetic layer **304**, etching magnetic layer **304** to pattern magnetic layer **304** in accordance with the patterned mask, and removing the patterned mask. The patterned mask may comprise any suitable material, such as photoresist for example, formed to any suitable thickness and may be patterned using any suitable technique. Magnetic layer **304** may be etched using any suitable etch technique, such as a suitable wet etching technique for example.

[0047] Forming magnetic layer **304** and/or patterning magnetic layer **304** to define one or more slots is optional.

[0048] For block **208**, a second dielectric layer **306** is formed over magnetic layer **304** as illustrated in **FIG. 4**.

Dielectric layer **306** corresponds to the dielectric layer between magnetic layer **120** and conductor **110** of **FIG. 1** and helps insulate magnetic layer **120** from conductor **110**. For one embodiment where magnetic layer **304** defines one or more slots, dielectric layer **306** fills each such slot. For one embodiment where magnetic layer **304** is patterned to define conductive underpass **126**, dielectric layer **306** fills the slots surrounding conductive underpass **126**.

[**0049**] Dielectric layer **306** may comprise any suitable dielectric material, such as an oxide of silicon for example, and may be formed to any suitable thickness using any suitable technique. For one embodiment, dielectric layer **306** is formed by depositing silicon dioxide (SiO_2) over magnetic layer **304** to a thickness of approximately 5000 angstroms (\AA) using a tetraethyl orthosilicate (TEOS) silicon dioxide (SiO_2) plasma enhanced chemical vapor deposition (PECVD) system.

[**0050**] For block **210**, dielectric layer **306** is patterned to define at least one via to magnetic layer **304**, such as vias **332** and **334** for example, as illustrated in **FIG. 5**. Dielectric layer **306** for one embodiment is patterned to define at least one via in region **132** within innermost turn **114** of conductor **110** as illustrated in **FIG. 1** to connect magnetic layer **304** with another magnetic layer. Dielectric layer **306** for one embodiment is patterned to define at least one via in one or more regions, such as regions **134** and **136** for example, along a perimeter surrounding outermost turn **118** of conductor **110** as illustrated in **FIG. 1**. For one embodiment where magnetic layer **304** defines conductive underpass **126** extending across the perimeter to node **112** and conductor **110** defines a conductive connection extending across the perimeter to node **116**, as illustrated in **FIG. 1**, dielectric layer **306** is not patterned with any via along the perimeter in such regions. For one embodiment where magnetic layer **304** defines conductive underpass **126**, dielectric layer **306** is patterned to form a via to conductive underpass **126** to connect node **112** to conductive underpass **126**.

[**0051**] Dielectric layer **306** may be patterned using any suitable patterning technique. Dielectric layer **306** for one embodiment is patterned by forming a patterned mask over dielectric layer **306**, etching dielectric layer **306** to pattern dielectric layer **306** in accordance with the patterned mask, and removing the patterned mask. The patterned mask may comprise any suitable material, such as photoresist for example, formed to any suitable thickness and may be patterned using any suitable technique. Dielectric layer **306** may be etched using any suitable etch technique, such as a suitable dry etch technique for example.

[**0052**] Forming dielectric layer **306** is optional. Dielectric layer **306** may not be formed, for example, where magnetic layer **304** is not formed. Patterning dielectric layer **306** to define one or more vias to magnetic layer **304** is optional. Dielectric layer **306** may not be patterned, for example, where magnetic layer **304** does not define conductive underpass **126** and where magnetic layer **304** is not to be connected to another magnetic layer.

[**0053**] For block **212**, a conductive layer **308** is formed over dielectric layer **306** as illustrated in **FIG. 5**. For one embodiment where dielectric layer **306** defines one or more vias to magnetic layer **304**, conductive layer **308** fills any such vias.

[**0054**] Conductive layer **308** may comprise any suitable conductive material and may be formed to any suitable

thickness using any suitable technique. Suitable conductive materials include copper (Cu), aluminum (Al), an aluminum-copper (AlCu) alloy, an aluminum-silicon (AlSi) alloy, an aluminum-copper-silicon (AlCuSi) alloy, and polysilicon for example. For one embodiment, conductive layer **308** is formed by sputter depositing an aluminum-copper (AlCu) alloy over dielectric layer **306** to a thickness of approximately 1 micron (μm). Conductive layer **308** for one embodiment may also be formed to comprise an underlying adhesion and/or diffusion barrier layer and/or an overlying adhesion and/or diffusion barrier layer. Conductive layer **308** may also be formed to comprise any overlying layer to prevent hillocking of the conductive material for conductive layer **308**. For one embodiment where conductive layer **308** comprises an aluminum-copper alloy, a titanium (Ti) layer may be deposited prior to depositing the aluminum-copper alloy and another titanium (Ti) layer may be deposited over the deposited aluminum-copper alloy.

[**0055**] For block **214**, conductive layer **308** is patterned to form conductor **110** as illustrated in **FIGS. 1** and **6**. Conductive layer **308** may be patterned to define a signal path having any suitable width, thickness, and length and any suitable spacing between turns to form a generally spiral-shaped conductor **110** covering an area of any suitable shape and size. For one embodiment where dielectric layer **306** defines one or more vias to magnetic layer **304**, conductive layer **308** is also patterned to remove conductive layer **308** from any such vias. Where magnetic layer **304** defines conductive underpass **126**, however, conductive layer **308** for one embodiment is not removed from any via to conductive underpass **126**. In this manner, conductive layer **308** helps connect conductive underpass **126** to node **112** of conductor **110**.

[**0056**] Conductive layer **308** may be patterned using any suitable patterning technique. Conductive layer **308** for one embodiment is patterned by forming a patterned mask over conductive layer **308**, etching conductive layer **308** to pattern conductive layer **308** in accordance with the patterned mask, and removing the patterned mask. The patterned mask may comprise any suitable material, such as a photoresist and a silicon dioxide (SiO_2) hard mask for example, formed to any suitable thickness and may be patterned using any suitable technique. Conductive layer **308** may be etched using any suitable etch technique, such as a suitable plasma dry etching technique for example.

[**0057**] For block **216**, a third dielectric layer **310** is formed over conductive layer **308** as illustrated in **FIG. 6**. Dielectric layer **310** for one embodiment helps insulate conductive layer **308** from another magnetic layer. Dielectric layer **310** fills the areas removed from conductive layer **308** in patterning conductive layer **308** to form conductor **110**. Dielectric layer **310** also fills any exposed vias in dielectric layer **306**.

[**0058**] Dielectric layer **310** may comprise any suitable dielectric material, such as an oxide of silicon for example, and may be formed to any suitable thickness using any suitable technique. For one embodiment, dielectric layer **310** is formed by depositing silicon dioxide (SiO_2) over conductive layer **308** to a thickness of approximately 5000 angstroms (\AA) using a tetraethyl orthosilicate (TEOS) silicon dioxide (SiO_2) plasma enhanced chemical vapor deposition (PECVD) system.

[0059] For block 218, dielectric layer 310 is patterned to define at least one via extending to magnetic layer 304 as illustrated in FIG. 7. Dielectric layer 310 for one embodiment is patterned to define a via extending through each exposed via defined by dielectric layer 306.

[0060] Dielectric layer 310 may be patterned using any suitable patterning technique. Dielectric layer 310 for one embodiment is patterned by forming a patterned mask over dielectric layer 310, etching dielectric layer 310 to pattern dielectric layer 310 in accordance with the patterned mask, and removing the patterned mask. The patterned mask may comprise any suitable material, such as photoresist for example, formed to any suitable thickness and may be patterned using any suitable technique. Dielectric layer 310 may be etched using any suitable etch technique, such as a suitable dry etch technique for example.

[0061] Forming dielectric layer 310 is optional. Dielectric layer 310 may not be formed, for example, where another magnetic layer is not to be formed over conductive layer 308. Patterning dielectric layer 310 to define one or more vias to magnetic layer 304 is optional. Dielectric layer 310 may not be patterned, for example, where magnetic layer 304 is not formed or where magnetic layer 304 is not to be connected to another magnetic layer formed over conductive layer 308.

[0062] For block 220, a second magnetic layer 312 is formed over dielectric layer 302 as illustrated in FIG. 7. For one embodiment where dielectric layers 306 and 310 define one or more vias to magnetic layer 304, magnetic layer 312 fills any such vias. In this manner, magnetic layer 312 helps form one or more connections between magnetic layer 304 and magnetic layer 312.

[0063] Magnetic layer 312 may comprise any suitable magnetic material and may be formed to any suitable thickness using any suitable technique. For one embodiment, magnetic layer 312 is formed by sputter depositing an amorphous cobalt (Co) alloy, such as a suitable cobalt-zirconium-tantalum (CoZrTa) alloy for example, to a thickness in the range of approximately 0.2 microns (μm) to approximately 1.0 micron (μm) over dielectric layer 310. The magnetic material for one embodiment for magnetic layer 312 may be deposited in the presence of an applied magnetic field to induce desirable magnetic properties in magnetic layer 312.

[0064] For block 222, magnetic layer 312 is patterned to define at least one slot, such as slot 342 for example, as illustrated in FIG. 7. Magnetic layer 312 may be patterned to define any suitable number of one or more slots with any suitable dimensions and orientation at any suitable one or more locations. Magnetic layer 312 for one embodiment is patterned to define slots having a width in the range of approximately 0.05 microns (μm) to approximately 15 microns (μm).

[0065] Magnetic layer 312 may be patterned using any suitable patterning technique. Magnetic layer 312 for one embodiment is patterned by forming a patterned mask over magnetic layer 312, etching magnetic layer 312 to pattern magnetic layer 312 in accordance with the patterned mask, and removing the patterned mask. The patterned mask may comprise any suitable material, such as photoresist for example, formed to any suitable thickness and may be

patterned using any suitable technique. Magnetic layer 312 may be etched using any suitable etch technique.

[0066] Forming magnetic layer 312 and/or patterning magnetic layer 312 to define one or more slots is optional.

[0067] Although illustrated as comprising conductive underpass 126 defined by magnetic layer 304, inductor 100 for another embodiment may instead comprise a similar conductive overpass defined by magnetic layer 312 to allow a voltage potential to be applied to node 112.

[0068] For another embodiment, inductor 100 may be fabricated such that a voltage potential may be applied to node 112 and/or node 116 from beneath magnetic layer 304. Also, inductor 100 may be fabricated such that a voltage potential may be applied to node 112 and/or node 116 from above magnetic layer 312. Nodes 112 and/or 116 may be conductively coupled to a respective contact beneath and/or above inductor 100 by forming a respective via through magnetic layer 304 and/or magnetic layer 312 and filling the via with a suitable conductive material. For another embodiment, a portion of magnetic layer 304 and/or magnetic layer 312 may be isolated to serve as a conductive contact in conductively coupling nodes 112 and/or 116 to a respective contact beneath and/or above inductor 100. By conductively coupling both nodes 112 and 116 through magnetic layer 304 and/or magnetic layer 312 in this manner, magnetic layers 304 and 312 may be connected continuously along the full perimeter surrounding outermost turn 118.

[0069] For one embodiment where inductor 100 comprises only magnetic layer 304 or magnetic layer 312, dielectric layer 306 and/or dielectric layer 310 may nevertheless be patterned with at least one via in region 132 and/or in one or more regions along a perimeter surrounding conductor 110, as illustrated in FIG. 1, for subsequent filling with a suitable magnetic material.

[0070] Inductor 100 for another embodiment is fabricated using a suitable damascene process to form conductor 110. Rather than forming and patterning conductive layer 308, dielectric layer 306 or another dielectric layer formed over dielectric layer 306 may be patterned to define suitable trenches and/or vias such that a conductive material, such as copper (Cu) for example, may be deposited over the dielectric layer and polished with a suitable chemical-mechanical polishing (CMP) technique, for example, to form conductor 110. One or more vias to magnetic layer 304 may then be defined through the dielectric layer.

[0071] Magnetic Layer Processing

[0072] Magnetic layers 304 and 312 may each be formed and patterned in any suitable manner. For one embodiment, each magnetic layer 304 and 312 is formed and patterned in accordance with flow diagram 800 as illustrated in FIG. 8. Flow diagram 800 is described in the context of magnetic layer 304 for the sake of simplicity.

[0073] For block 802 of FIG. 8, an underlying layer 902 is formed over dielectric layer 302 as illustrated in FIG. 9. Layer 902 may serve as an adhesion layer and/or as a diffusion barrier layer for magnetic layer 304.

[0074] Layer 902 may comprise any suitable material and may be formed to any suitable thickness using any suitable technique. For one embodiment where the magnetic material for magnetic layer 304 comprises an amorphous cobalt (Co)

alloy, such as CoZrTa for example, titanium (Ti) may be sputter deposited over dielectric layer 302 to a suitable thickness, such as approximately 250 angstroms (Å) for example, using a physical vapor deposition (PVD) system, for example, to form layer 902. Titanium (Ti) helps the cobalt (Co) alloy adhere to dielectric layer 302.

[0075] Layer 902 is optional and may not be used, for example, where adhesion and/or diffusion are of minimized concern for the magnetic material of magnetic layer 304.

[0076] For block 804 of FIG. 8, a magnetic material layer 904 is formed over underlying layer 902 as illustrated in FIG. 9. Magnetic material layer 904 may comprise any suitable material and may be formed to any suitable thickness using any suitable technique.

[0077] Magnetic material layer 904 for one embodiment comprises cobalt (Co). Magnetic material layer 904 for one embodiment comprises an amorphous cobalt (Co) alloy comprising cobalt (Co) and any suitable one or more elements of any suitable atomic or weight percentage. The amorphous cobalt (Co) alloy may have any suitable atomic order. For one embodiment, the amorphous cobalt (Co) alloy has an atomic order in the range of approximately 1 angstrom (Å) to approximately 100 angstroms (Å). For one embodiment, the amorphous cobalt (Co) alloy has an atomic order in the range of approximately 1 angstrom (Å) to approximately 25 angstroms (Å). For one embodiment, the amorphous cobalt (Co) alloy has an atomic order in the range of approximately 1 angstrom (Å) to approximately 10 angstroms (Å).

[0078] Magnetic material layer 904 for one embodiment comprises an amorphous cobalt (Co) alloy comprising cobalt (Co) and zirconium (Zr). Zirconium (Zr) helps make cobalt (Co) amorphous. Magnetic material layer 904 for one embodiment comprises a cobalt-zirconium (CoZr) alloy having one or more additional elements, such as tantalum (Ta) and niobium (Nb) for example, that help make the cobalt-zirconium (CoZr) alloy magnetically softer. Magnetic material layer 904 for one embodiment comprises a cobalt-zirconium (CoZr) alloy having one or more additional elements, such as a rare earth element for example, that help increase the ferromagnetic resonance of the cobalt-zirconium (CoZr) alloy. Rare earth elements include rhenium (Re), neodymium (Nd), praseodymium (Pr), and dysprosium (Dy) for example. Rhenium (Re) helps reduce stress and magnetostriction for the cobalt-zirconium (CoZr) alloy.

[0079] Where magnetic material layer 904 comprises a cobalt-zirconium (CoZr) alloy, magnetic material layer 904 may comprise, for example, approximately 3 atomic percent to approximately 10 atomic percent zirconium (Zr).

[0080] Where magnetic material layer 904 comprises a cobalt-zirconium-tantalum (CoZrTa) alloy, magnetic material layer 904 may comprise, for example, approximately 3 atomic percent to approximately 10 atomic percent zirconium (Zr) and may comprise up to and including approximately 10 atomic percent tantalum (Ta). Magnetic material layer 904 for one embodiment comprises approximately 91.5 atomic percent cobalt (Co), approximately 4 atomic percent zirconium (Zr), and approximately 4.5 atomic percent tantalum (Ta). Such a CoZrTa alloy can operate in the gigaHertz range and can withstand temperatures up to

approximately 450° Celsius without crystallizing or significantly changing its relevant properties.

[0081] Where magnetic material layer 904 comprises a cobalt-zirconium-rhenium (CoZrRe) alloy, magnetic material layer 904 may comprise, for example, approximately 3 atomic percent to approximately 10 atomic percent zirconium (Zr) and may comprise up to and including approximately 3 atomic percent rhenium (Re). Magnetic material layer 904 for one embodiment comprises approximately 89 atomic percent cobalt (Co), approximately 8 atomic percent zirconium (Zr), and approximately 3 atomic percent rhenium (Re).

[0082] Magnetic material layer 904 may be formed to any suitable thickness. Magnetic material layer 904 for one embodiment has a thickness in the range of approximately 0.05 microns (μm) to approximately 2.0 microns (μm). Magnetic material layer 904 for one embodiment has a thickness in the range of approximately 0.2 microns (μm) to approximately 1.0 micron (μm). Magnetic material layer 904 for one embodiment has a thickness of approximately 0.4 microns (μm).

[0083] Magnetic material layer 904 for one embodiment is sputter deposited using a physical vapor deposition (PVD) system, for example. Magnetic material layer 904 for one embodiment is deposited in the presence of an applied magnetic field to induce desirable magnetic properties in magnetic material layer 904. Magnetic material layer 904 may be deposited, for example, in the presence of a fixed magnetic field, an approximately 180° switching magnetic field, or an orthogonal switching magnetic field.

[0084] Magnetic material layer 904 for one embodiment may be deposited in sublayers of any suitable thickness, such as approximately 0.2 microns (μm) for example, to help prevent overheating and crystal growth during deposition. Each sublayer for one embodiment may be deposited in the presence of a magnetic field in such a manner so as to induce a magnetic anisotropy in the sublayer in a direction parallel to the plane of the sublayer and orthogonal to that of another sublayer. Each sublayer may, for example, be deposited in the presence of an orthogonal switching magnetic field. Substrate 300 may also be repositioned relative to a fixed magnetic field as each sublayer is deposited so as to induce the orthogonal magnetic fields.

[0085] For block 806 of FIG. 8, an overlying layer 906 is formed over magnetic material layer 904 as illustrated in FIG. 9. Layer 906 may serve as an adhesion layer and/or as a diffusion barrier layer for magnetic layer 304. Layer 906 may comprise any suitable material and may be formed to any suitable thickness using any suitable technique.

[0086] For one embodiment where magnetic material layer 904 comprises cobalt (Co), titanium (Ti) may be sputter deposited over magnetic material layer 904 to a suitable thickness, such as approximately 250 angstroms (Å) for example, using a physical vapor deposition (PVD) system, for example, to form layer 906. Titanium (Ti) helps cobalt (Co) adhere to photoresist in patterning magnetic layer 304, helps protect cobalt (Co) from relatively high temperature processes that could potentially oxidize the top surface of magnetic material layer 904 and possibly damage the relevant properties of cobalt (Co), and may help reduce any undercutting in etching magnetic material layer 904.

[0087] For another embodiment where magnetic material layer 904 comprises cobalt (Co), magnetic material layer 904 is oxidized to form layer 906 comprising cobalt oxide (CoO_x). Cobalt oxide (CoO_x) may be formed to any suitable thickness, such as in the range of approximately 10 angstroms (\AA) to approximately 100 angstroms (\AA) for example. Magnetic material layer 904 for one embodiment is briefly ashed with a suitable relatively low lamp, low temperature recipe to oxidize cobalt (Co) while minimizing any damage to the relevant properties of cobalt (Co). Oxidizing cobalt (Co) in this manner helps cobalt (Co) adhere to photoresist in patterning magnetic layer 304.

[0088] Layer 906 is optional and may not be used, for example, where adhesion is of minimized concern for the magnetic material of magnetic layer 304.

[0089] For block 808, a patterned mask layer 908 is formed over magnetic layer 304 as illustrated in FIG. 10. Mask layer 908 may comprise any suitable material and may have any suitable thickness. Mask layer 908 may be patterned using any suitable technique. Mask layer 908 for one embodiment comprises photoresist that is spun on and then patterned by exposing mask layer 908 through a suitable mask and developing mask layer 908.

[0090] For block 810, underlying layer 902, magnetic material layer 904, and overlying layer 906 are etched as illustrated in FIG. 10. Magnetic layer 304 for one embodiment is etched using a suitable wet etching technique. For one embodiment where layer 906 comprises titanium (Ti) or cobalt oxide (CoO_x), a suitable dilute hydrofluoric (HF) acid solution is used to etch layer 906 exposed by mask layer 908. For one embodiment, an approximately 50:1 HF acid solution is used. For one embodiment where magnetic material layer 904 comprises cobalt (Co), a solution of nitric acid is used to wet etch magnetic material layer 904 exposed by mask layer 908. For one embodiment, an approximately 10% solution of nitric (HNO_3) acid is used. For one embodiment where layer 906 comprises titanium (Ti), layer 906 helps reduce any undercutting in wet etching magnetic material layer 904. For one embodiment where layer 902 comprises titanium (Ti), a suitable dilute hydrofluoric (HF) acid solution is used to etch layer 902 exposed by mask layer 908. For one embodiment, an approximately 50:1 HF acid solution is used.

[0091] As substrate 300 is further processed in accordance with flow diagram 200 of FIG. 2, for example, each subsequent process technique is to account for the presence of magnetic layer 304. As one example where magnetic layer 304 comprises cobalt (Co), exposing magnetic layer 304 to a plasma or atmosphere containing oxygen at relatively high temperatures may damage the relevant properties of magnetic layer 304. The effects of subsequent process techniques on magnetic layer 304 may be monitored using a permeance meter, for example.

[0092] For one embodiment where magnetic layer 304 comprises cobalt (Co), silicon dioxide (SiO_2) is deposited to form dielectric layer 306, for example, using a suitable plasma enhanced chemical vapor deposition (PECVD) system with tetraethyl orthosilicate (TEOS) to help minimize oxidation and crystallization of magnetic layer 304.

[0093] For one embodiment where photoresist, for example, is to be removed from magnetic layer 304, dielec-

tric layer 306, and/or from a silicon dioxide (SiO_2) hard mask over conductive layer 308, a suitable relatively low temperature resist strip technique and a suitable solvent may be used instead of a typical relatively high temperature ash technique to avoid exposing magnetic layer 304 to plasmas at relatively high temperatures for relatively long periods of time. For another embodiment where photoresist, for example, is used in etching silicon dioxide (SiO_2), such as for dielectric layer 306 for example, the silicon dioxide (SiO_2) may be etched using a suitable relatively low power and relatively low temperature dry etch technique to help minimize any hardening of the photoresist. The photoresist may then be removed using a suitable solvent.

[0094] Following fabrication of inductor 100 with magnetic layer 304 and/or magnetic layer 312, magnetic layer 304 and/or magnetic layer 312 may be annealed by exposing inductor 100 to a suitable temperature in the presence of a magnetic field to help vitalize the magnetic properties of magnetic layer 304 and/or magnetic layer 312.

[0095] Although described in the context of inductor 100, one or more magnetic layers may be formed and possibly patterned in fabricating or packaging any suitable integrated circuit.

[0096] Low Resistance Inductor Fabrication

[0097] One or more magnetic layers may be formed and possibly patterned, for example, in fabricating an inductor 1100 as illustrated in FIG. 11.

[0098] Inductor 1100 comprises a conductive layer 1108 defining a signal path along a row 1120 of alternating pedestals 1121, 1123, 1125, and 1127 and trenches 1122, 1124, and 1126, across an interconnect portion 1130, and along another row 1140 of alternating pedestals 1141, 1143, and 1145 and trenches 1142 and 1144. Although illustrated as defining two rows 1120 and 1140, inductor 1100 may define any suitable number of one or more rows of any suitable number of one or more pedestals and trenches.

[0099] Current may flow along the signal path in opposite directions for each adjacent row to generate an electromagnetic field. Because the signal path is defined along rows rather than turns in a spiral, inductor 1100 may be fabricated to define a relatively wide signal path and may therefore be fabricated with a lower resistance relative to inductor 100. Also, unlike inductor 100 where magnetic flux is driven into its supporting substrate, inductor 1100 generates a magnetic flux parallel to its supporting substrate, reducing concern for induced Eddy currents in the substrate.

[0100] Conductive layer 1108 comprises a lower segment for each trench, such as lower segment 1154 for trench 1124 for example, and an upper segment for each pedestal, such as upper segment 1155 for pedestal 1125 for example. For one embodiment, each upper segment may be relatively longer than each lower segment. For other embodiments, the relative length of the upper and lower segments may differ. The length of each row for one embodiment is substantially greater than its width.

[0101] For one embodiment, the pedestals and trenches in each row are displaced by approximately 180° from the pedestals and trenches in an adjacent row to help align the magnetic flux across each row and therefore help increase the resulting inductance of inductor 1100. Inductor 1100

may optionally comprise a magnetic layer **1104** beneath conductive layer **1108** in each pedestal and/or a magnetic layer **1112** over conductive layer **1108** in each trench to help increase the inductance of inductor **1100**. Each pedestal may optionally have magnetic layer **1112** over conductive layer **1108**. For other embodiments, displacement of pedestals and trenches between adjacent rows may differ from 180°.

[0102] Inductor **1100** may be fabricated in any suitable manner. For one embodiment, inductor **1100** is fabricated in accordance with flow diagram **1200** as illustrated in FIG. 12. The processing techniques described in connection with blocks **202-222** of FIG. 2 are generally applicable to blocks **1202-1222**, respectively, of FIG. 12 except where noted.

[0103] For block **1202** of FIG. 12, a first dielectric layer **1102** is formed over a substrate **1101** comprising semiconductor material. A first magnetic layer **1104** is formed for block **1204** over dielectric layer **1102**. Magnetic layer **1104** is patterned for block **1206** to help define pedestals and trenches for inductor **1100**.

[0104] Unlike block **206** of FIG. 2 where dielectric layer **302** is not patterned to fabricate inductor **100**, dielectric layer **1102** is patterned for block **1206** as well to help define pedestals and trenches for inductor **1100**. For one embodiment where dielectric layer **1102** comprises silicon dioxide (SiO₂) and photoresist is used to pattern dielectric layer **1102**, a relatively high power dry etch technique may be used followed by use of a suitable relatively low temperature resist strip technique and a suitable solvent to remove the photoresist.

[0105] A second dielectric layer **1106** is formed for block **1208** over magnetic layer **1104** and along the walls and bottom of the trenches for inductor **1100**. Dielectric layer **1106** is patterned for block **1210**. A conductive layer **1108** is formed for block **1212** over dielectric layer **1106**. Conductive layer **1108** is patterned for block **1214** to form a conductor defining a signal path along one or more rows of pedestals and trenches.

[0106] A third dielectric layer **1110** is formed for block **1216** over conductive layer **1108**. Dielectric layer **1110** is patterned for block **1218**. A second magnetic layer **1112** is formed for block **1220** over dielectric layer **1110**. Magnetic layer **1112** is patterned for block **1222**.

[0107] Integrated Circuit and Integrated Circuit Package

[0108] As illustrated in block diagram form in FIG. 13, inductor **100** for one embodiment may be integrated in an integrated circuit **1300** with any suitable one or more integrated circuit devices, such as integrated circuit devices **1302** and **1304** for example, or with any suitable circuits comprising one or more integrated circuit devices, such as integrated circuit devices **1302** and **1304** for example. Although illustrated as comprising two inductors **100**, integrated circuit **1300** may be fabricated with any suitable number of one or more inductors **100** and/or **1100** and/or any other suitable inductor having one or more magnetic layers.

[0109] As illustrated in block diagram form in FIG. 14, inductor **100** for one embodiment may be mounted in an integrated circuit package **1400** for conductive coupling to an integrated circuit **1402** housed by integrated circuit package **1400**. Inductor **100** may be integrated with or mounted in integrated circuit package **1400** and conduc-

tively coupled to integrated circuit **1402** in any suitable manner. Although illustrated as comprising two inductors **100**, integrated circuit package **1400** may be fabricated with any suitable number of one or more inductors **100** and/or **1100** and/or any other suitable inductor having one or more magnetic layers.

[0110] Although described in connection with inductor **100** and inductor **1100**, magnetic layers may be integrated in the fabrication of other suitable inductors having other suitable structures. As one example, inductor **100** may be fabricated with a multi-level conductor formed across multiple layers and/or with multiple conductors.

[0111] In the foregoing description, the invention has been described with reference to specific exemplary embodiments thereof. It will, however, be evident that various modifications and changes may be made thereto without departing from the broader spirit or scope of the present invention as defined in the appended claims. The specification and drawings are, accordingly, to be regarded in an illustrative rather than a restrictive sense.

What is claimed is:

1. An inductor comprising:

a substrate comprising a semiconductor material;

a first dielectric layer over the substrate;

a magnetic layer over the first dielectric layer;

a second dielectric layer over the magnetic layer; and

a conductor over the second dielectric layer.

2. The inductor of claim 1, wherein the magnetic layer comprises cobalt.

3. The inductor of claim 1, wherein the magnetic layer comprises an amorphous alloy comprising cobalt.

4. The inductor of claim 1, wherein the magnetic layer comprises an amorphous alloy comprising cobalt and zirconium.

5. The inductor of claim 1, wherein the magnetic layer comprises an amorphous alloy comprising cobalt; zirconium; and tantalum, niobium, rhenium, or a rare earth element.

6. The inductor of claim 1, wherein the magnetic layer defines at least one slot.

7. The inductor of claim 1, comprising:

a third dielectric layer over the conductor; and

another magnetic layer over the third dielectric layer.

8. The inductor of claim 7, wherein the other magnetic layer defines at least one slot.

9. The inductor of claim 7, wherein the magnetic layers are connected.

10. The inductor of claim 1, wherein the conductor defines a generally spiral-shaped signal path having at least one turn.

11. The inductor of claim 1, wherein the first dielectric layer and the magnetic layer define one or more trenches and wherein the conductor defines a signal path along the one or more trenches.

12. An inductor comprising:

a substrate comprising a semiconductor material;

a first dielectric layer over the substrate;

a conductor over the first dielectric layer;

a second dielectric layer over the conductor; and

a magnetic layer over the second dielectric layer, wherein the magnetic layer comprises cobalt.

13. The inductor of claim 12, wherein the magnetic layer comprises an amorphous alloy comprising cobalt.

14. The inductor of claim 12, wherein the magnetic layer comprises an amorphous alloy comprising cobalt and zirconium.

15. The inductor of claim 12, wherein the magnetic layer comprises an amorphous alloy comprising cobalt; zirconium; and tantalum, niobium, rhenium, or a rare earth element.

16. The inductor of claim 12, wherein the magnetic layer defines at least one slot.

17. The inductor of claim 12, wherein the conductor defines a generally spiral-shaped signal path having at least one turn.

18. The inductor of claim 12, wherein the first dielectric layer defines one or more trenches and wherein the conductor defines a signal path along the one or more trenches.

19. A method comprising:

forming a first dielectric layer over a substrate comprising a semiconductor material;

forming a magnetic layer over the first dielectric layer;

forming a second dielectric layer over the magnetic layer; and

forming a conductor over the second dielectric layer.

20. The method of claim 19, wherein the forming the magnetic layer comprises forming a magnetic layer comprising cobalt.

21. The method of claim 19, wherein the forming the magnetic layer comprises forming a magnetic layer comprising an amorphous alloy comprising cobalt.

22. The method of claim 19, wherein the forming the magnetic layer comprises forming a magnetic layer comprising an amorphous alloy comprising cobalt and zirconium.

23. The method of claim 19, wherein the forming the magnetic layer comprises forming a magnetic layer comprising an amorphous alloy comprising cobalt; zirconium; and tantalum, niobium, rhenium, or a rare earth element.

24. The method of claim 19, comprising patterning the magnetic layer to define at least one slot.

25. The method of claim 19, comprising:

forming a third dielectric layer over the conductor; and

forming another magnetic layer over the third dielectric layer.

26. The method of claim 25, comprising patterning the other magnetic layer to define at least one slot.

27. The method of claim 25, comprising connecting the magnetic layers.

28. The method of claim 19, comprising patterning the conductor to define a generally spiral-shaped signal path having at least one turn.

29. The method of claim 19, comprising patterning the first dielectric layer and the magnetic layer to define one or more trenches such that the conductor defines a signal path along the one or more trenches.

30. A method comprising:

forming a first dielectric layer over a substrate comprising a semiconductor material;

forming a conductor over the first dielectric layer;

forming a second dielectric layer over the conductor; and

forming a magnetic layer over the second dielectric layer, wherein the magnetic layer comprises cobalt.

31. The method of claim 30, wherein the forming the magnetic layer comprises forming a magnetic layer comprising cobalt.

32. The method of claim 30, wherein the forming the magnetic layer comprises forming a magnetic layer comprising an amorphous alloy comprising cobalt.

33. The method of claim 30, wherein the forming the magnetic layer comprises forming a magnetic layer comprising an amorphous alloy comprising cobalt and zirconium.

34. The method of claim 30, wherein the forming the magnetic layer comprises forming a magnetic layer comprising an amorphous alloy comprising cobalt; zirconium; and tantalum, niobium, rhenium, or a rare earth element.

35. The method of claim 30, comprising patterning the magnetic layer to define at least one slot.

36. The method of claim 30, comprising patterning the conductor to define a generally spiral-shaped signal path having at least one turn.

37. The method of claim 30, comprising patterning the first dielectric layer to define one or more trenches such that the conductor defines a signal path along the one or more trenches.

* * * * *