

Feb. 6, 1951

R. A. FERGUSON

2,540,435

ELECTRIC SWITCH

Filed Jan. 13, 1950

Fig. 1.

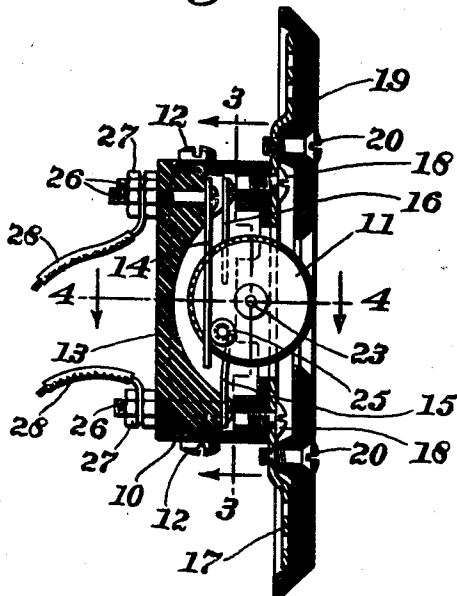

Fig. 2.

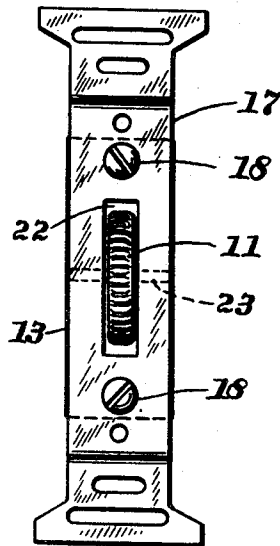

Fig. 3.

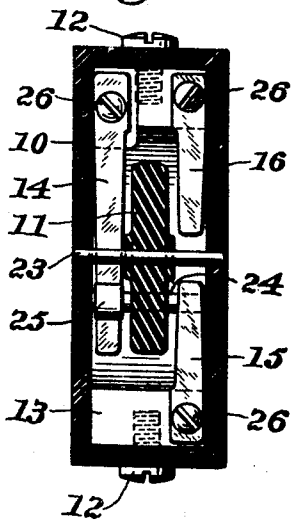

Fig. 4.

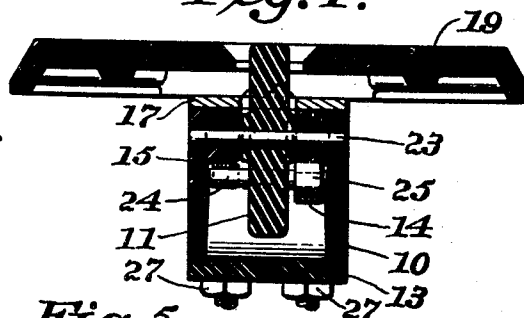
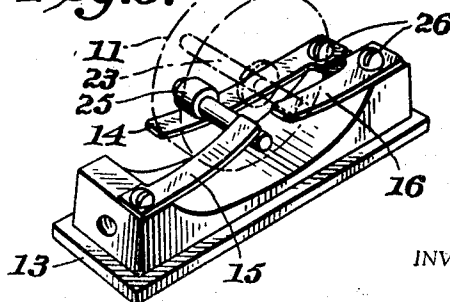

Fig. 5.



INVENTOR:

Robert H. Ferguson,

BY *Cushman, Darby & Cushman*
ATTORNEYS.

UNITED STATES PATENT OFFICE

2,540,435

ELECTRIC SWITCH

Robert A. Ferguson, Washington, D. C.

Application January 13, 1950, Serial No. 138,447

14 Claims. (Cl. 200—154)

1

This invention relates to improvements in electric wall switches, and more particularly, to switches of the slow break and quick make type.

It is an object of this invention to provide a novel and improved wall switch which will be smooth and noiseless in operation and which will retain the "feel" of a snap type switch.

A further object is to provide a noiseless switch which produces a very small arc, as distinguished from the elongated arc produced by abrupt operation of conventional snap-acting switch mechanisms.

A further important object is to provide a switch constructed of a minimum of parts which can be easily and economically manufactured and assembled.

In the accompanying drawings,

Figure 1 is a view taken in section through the switch housing mounted on a switch bracket and cover plate.

Figure 2 is a plan view of the switch and bracket.

Figure 3 is a sectional view taken along the line 3—3 of Figure 1.

Figure 4 is a sectional view taken along the line 4—4 of Figure 1.

Figure 5 is a perspective view of the switch mechanism showing one of the contacts in closed position with the bridging pin.

Referring to the drawings, which disclose a preferred embodiment of this invention, a two part casing is provided for the switch mechanism consisting of a housing 10 provided with a relatively narrow rectangular opening 22 at one end through which a portion of the periphery of the disk 11 projects. The housing is formed at the bottom with a substantially rectangular recess for receiving the base member 13 which is fastened to the side walls of the housing by screws 12 and provides a support for the strip contacts 14, 15 and 16. The housing is attached to a conventional wall switch bracket 17 by the screws 18, and a standard switch cover plate 19 may be secured to the bracket by the screws 20 with the disk partially projecting through the opening 22.

The disk 11 is mounted for oscillation upon a centrally disposed transverse member or pin 23 supported by the side walls of the housing and is provided with a bridging pin or stud 24 radially offset from the axis of rotation of the disk and projecting outwardly or perpendicular from each end face of the disk. One end of the bridging pin 24 is provided with a roller 25 which is adapted to rotate relative to the pin.

2

The disk 11 is made of dielectric material and the bridging pin is made of conductive material.

The base member 13 is made of dielectric material and is provided with three integral supports to which are secured the flexible strip contacts 14, 15 and 16. The contacts are clamped to the supports by the screws 26 which terminate on the outside of the base and are provided with double nuts 27 between which the lead wires 28 are clamped. The strip contact 14 extends parallel and across the end face of the disk and is biased tangentially against the lower or outer surface of the roller 25 mounted on one end of the bridging pin 24. The pair of flexible contact strips 15 and 16 are relatively short with their free ends aligned and displaced from each other and will alternately contact tangentially the opposite end of the bridging pin at the "off" and "on" positions. The supports for the pair of short contact strips 15 and 16 are elevated with respect to the support of the long strip contact 14 so that the short strips will engage the pin on the opposite side from that which the long strip contacts. It is thus seen that the short strips act as stops for the bridging pin 24 which hold the disk from further rotation at each end of its arc of rotation.

The periphery of the disk 11 is preferably knurled and projects through the slot in the wall cover plate 19 as described above. The disk is readily accessible as clearly indicated in Figure 1 for engagement by the operator's finger for rotation in a clockwise direction. The long strip contact 14 is made of relatively stiff, flexible, conducting material and is biased against the roller so that it tends to force the opposite end of the bridging pin 24 into engagement with one of the short contacts 15 as shown in Figure 1. As the disk is manually oscillated in a clockwise direction, the roller 25 will force the long contact 14 inwardly of the base member 13 (Fig. 1) when initial torque is applied to the disk, and the short contact 15 will follow the roller for some distance so that a slow break is provided. After the disk 11 is rotated so that the roller 25 reaches the bottom or center of its arc, the long spring contact 14 will act to force the bridging member 24 upwardly into rapid engagement with the short contact strip 16, thereby providing a fast make. The shaft 24 through the roller 25 is in continuous engagement with the long strip contact 14 and intermittently engages one of the two short strip contacts 15 and 16 upon oscillation of the disk. The disk operates smoothly and quietly and by reason of the bias of the long



of said oscillatable member, and said oscillatable member having a transverse pin extending outwardly from opposite sides thereof, said pin constantly engaging one of said contacts and arranged alternately to engage the other contacts when moved to either of two positions, the ends of said pin arranged to engage the spaced flexible contacts so as to limit the rotation of the oscillatable member when the switch is actuated.

7. An electric switch as called for in claim 4 in which the transverse pin has a roller on one end in engagement with one of said contacts.

8. An electric switch as called for in claim 5 in which the transverse pin has a roller on one end thereof in engagement with said long flexible contact so as to provide means for insuring a slow break and a quick make when the switch is operated to open or close the circuits with which it is associated.

9. An electric switch of the class described having in combination, a revoluble member, a bridging pin extending transversely from said member, a long flexible contact positioned on one side of said member and supported for continuous tangential engagement with said pin, said long contact being biased towards said pin, and a pair of spaced yieldable contacts on the opposite side of said revoluble member and supported for intermittent tangential contact with the other end of said pin, the parts being constructed and arranged so that the bridging member alternately electrically connects the long strip contact with one of said short contacts when the revoluble member is oscillated to either of two positions.

10. In an electric switch of the class described, an oscillatable operating member, a transversely disposed bridging pin connected to said operating member, means for oscillating said member and said pin in an arcuate path, a flexible long strip contact supported for continuous tangential engagement with one end of said pin, said long strip contact being biased towards said pin, and two flexible short strip contact members mounted for intermittent engagement with the opposite end of said pin, said short strip contact members arranged alternately to engage said pin to limit the oscillatable movement of said member, the parts being constructed and arranged so that the bridging pin alternately electrically connects the long strip contact to one of said short contacts when the operable member is actuated to oscillate the pin.

11. In an electric switch of the class described, a manually revoluble member having a bridging pin extending outwardly from opposite sides thereof, a base, a spring contact connected at one end to said base and having its opposite end constantly in engagement with one end of said pin, and a pair of short contacts connected to said base on the opposite side of said revoluble member and having their free ends alternately engageable with the other end of said pin, the parts being constructed and arranged to provide means for producing a slow break of one circuit and establishing a quick make with the other circuit when the revoluble member is oscillated to either of two positions.

12. In an electric switch, an elongated substantially flat contact mounted for displacement against resilient pressure from a normal position, a conductive element mounted for bodily displace-

ment in an arcuate path intersecting the plane of the flat contact in said normal position and movable along the surface of the flat contact upon displacement thereof against said resilient pressure, whereby the element is urged toward one end of said contact or the other end thereof and is maintained constantly in engagement on one side with the flat contact, and a second contact spaced from the flat contact and positioned to be engaged by the opposite side of said conductive element under the force of the resilient pressure exerted on the flat contact when the conductive element is at one end of its path of movement and to be disengaged and spaced from the conductive element when the latter is at the other end of its path of movement.

13. In an electric switch, an elongated substantially flat contact mounted for displacement against resilient pressure from a normal position, a conductive element mounted for bodily displacement in an arcuate path intersecting the plane of the flat contact in said normal position and movable along the surface of the flat contact upon displacement thereof against said resilient pressure, whereby the element is urged toward one end of said contact or the other end thereof and is maintained constantly in engagement on one side with the flat contact, a second contact spaced from the flat contact and positioned to be engaged by the opposite side of said conductive element under the force of the resilient pressure exerted on the flat contact when the conductive element is at one end of its path of movement and to be disengaged and spaced from the conductive element when the latter is at the other end of its path of movement, and abutment means adjacent the last-mentioned end of the path of movement of the conductive element to limit its movement in the direction of the force of said resilient pressure.

14. In an electric switch, a base, an elongated spring contact member supported at one end by said base and having its opposite end free, a conductive contact element mounted for movement in an arcuate path along said spring contact member and in continuous engagement therewith and serving to displace the spring contact member as it moves along the same, a second contact member spaced from and adjacent the free end of the spring contact member, said second contact member being positioned to be engaged by said conductive contact element when the latter is adjacent the free end of the spring contact member, and the spring contact member serving to urge said conductive contact element into engagement with the second contact member when the contact element is adjacent the free end of the spring contact member.

ROBERT A. FERGUSON.

REFERENCES CITED

The following references are of record in the file of this patent:

UNITED STATES PATENTS

Number	Name	Date
347,767	Brown	Aug. 24, 1886
1,020,245	Abbe	Mar. 12, 1912
1,956,422	Hammerly	Apr. 28, 1934
2,031,202	Bier	Feb. 18, 1936
2,421,881	Heasty	June 10, 1947