

AMENDED

611829

FORM 1

COMMONWEALTH OF AUSTRALIA

Patents Act 1952

APPLICATION FOR A STANDARD PATENT
(CONVENTION)



1. SCOT YOUNG RESEARCH LIMITED, of Unit 1, Hayes Lane Industrial Estate, Folkes Road, Lye, West Midlands, DY9 8RN, England, (formerly called BRUTE LIMITED),

hereby applies for the grant of a standard patent for an invention entitled:

"CLEANING DEVICES"

which is described in the accompanying complete specification.

2. This is a Convention application, the details of the basic applications being as follows:-

<u>Application No.</u>	<u>Date</u>	<u>Country</u>
88 27233.1	22 November 1988	United Kingdom
89 03216.3	13 February 1989	United Kingdom

3. Address for service is:

PETER MAXWELL & ASSOCIATES
 Patent & Trade Mark Attorneys
 National Bank House
 255 Adelaide Street
 BRISBANE QLD 4000
 (GPO Box 3125, Brisbane, 4001)

DATED this 26th day of October, 1990.

SCOT YOUNG RESEARCH LIMITED
 By its Patent Attorneys
PETER MAXWELL & ASSOCIATES

.....
(Thomas G. Ahearn)

To: The Commissioner of Patents
COMMONWEALTH OF AUSTRALIA

COMMONWEALTH OF AUSTRALIA
The Patents Act 1952

DECLARATION IN SUPPORT OF AN
APPLICATION FOR A PATENT

In support of the Application made for a patent for an invention
entitled: "CLEANING DEVICES",

Insert
Title of Invention

Insert
Full Name and
Address of
declarant

I/We Ronald Alexander Young
of 4 Anderson Street, London SW3, GB
do solemnly and sincerely declare as follows:-

~~I am/We are the applicant(s) for the patent --~~
(or, in the case of an application by a body corporate)

Insert Full Name(s)
of applicant(s)

1. I am/~~We are~~ authorised by BRUTE LIMITED, of Unit 1, Hayes Lane
Industrial Estate, Folkes Road, Lye, West Midlands, DY9, 8RN, England
(formerly called "SCOT YOUNG SERVICE SYSTEMS LIMITED")
the applicant(s) for the patent to make this declaration on its/~~their~~ behalf.

~~2. I am/We are the actual inventor(s) of the invention referred to in the basic
application(s)~~

(or, where a person other than the inventor is the applicant)

Insert Full Name
and Address of each
Inventor

2. I, the said RONALD ALEXANDER YOUNG, of the above stated
address, am

~~is/are~~ the actual inventor(s) of the invention and the facts upon which the
applicant(s) is/~~are~~ entitled to make the application are as follows:-

State how Applicant(s)
derive title from inventor(s)
e.g. The Applicant(s)
is/are the assignee(s) of the
invention from the
inventor(s), or The invention
was made for the Applicant(s)
by the inventor(s) in the course
of his/their employment with
the Applicant(s).

The said BRUTE LIMITED is the assignee of
myself, RONALD ALEXANDER YOUNG.

3. The basic application(s) as defined by Section 141 of the Act ~~was/were~~ made
in the United Kingdom on 22 Nov 1988, and
~~by~~ in the United Kingdom on 13 February 1989, both
~~by~~ SCOT YOUNG SERVICE SYSTEMS LIMITED ~~or~~
~~by~~ (now called BRUTE LIMITED)

*Note: Paragraphs
3 and 4 need only be
completed for a
Convention Application

Basic Country(ies)
Priority Date(s)
Basic Applicant(s)

4. The basic application(s) referred to in paragraph 3 of this Declaration ~~was/~~
were the first application(s) made in a Convention country in respect of the
invention(s) the subject of the application.

Declared at LONDON this 13th day of November, 1989

To: The Commissioner of Patents

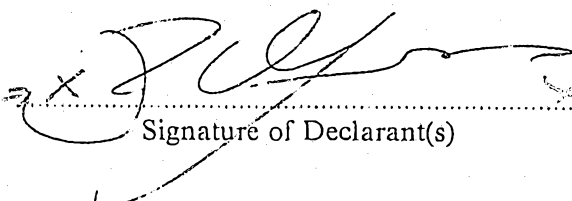
Please sign 
Signature of Declarant(s)

(12) PATENT ABRIDGMENT (11) Document No. AU-B-45419/89
(19) AUSTRALIAN PATENT OFFICE (10) Acceptance No. 611829

(54) Title
CLEANING DEVICES

International Patent Classification(s)

(51)⁴ A47L 013/29 A47L 013/20

(21) Application No. : 45419/89

(22) Application Date : 21.11.89

(30) Priority Data

(31) Number	(32) Date	(33) Country
8827233	22.11.88	GB UNITED KINGDOM
8903216	13.02.89	GB UNITED KINGDOM

(43) Publication Date : 31.05.90

(44) Publication Date of Accepted Application : 20.06.91

(71) Applicant(s)

SCOT YOUNG RESEARCH LIMITED

(72) Inventor(s)

RONALD ALEXANDER YOUNG

(74) Attorney or Agent

PETER MAXWELL & ASSOCIATES, GPO Box 3125, BRISBANE QLD 4001

(56) Prior Art Documents

AU 50094/79
AU 53501/73
AU 25455/49

(57) Claim

1. A cleaning device alternatively usable as a sweep mop in a conventional wet or damp mopping operation, or in a wiping or polishing operation, comprising a mop pad holder having attachment means for the mop pad and for the separate attachment of a sheet of wiping or polishing material, and wherein the attachment means for the mop pad comprise slots or apertures adjacent the ends of the holder so that the latter presents end bars around which end tails of the pad can respectively be wrapped, these end portions having complementary "hook and loop" type surfaces so that they adhere to themselves.

611829

COMMONWEALTH OF AUSTRALIA

Patents Act 1952

Name of Applicant: *Scot Young Research Limited*
~~BRUTE LIMITED~~

Address of Applicant: Unit 1,
Hayes Lane Industrial Estate,
Folkes Road,
Lye,
West Midlands, DY9 8RN,
England.

Actual Inventor: Ronald Alexander Young

Address for Service: PETER MAXWELL & ASSOCIATES
Patent and Trade Mark Attorneys
National Bank House
255 Adelaide Street
Brisbane, Queensland.



COMPLETE SPECIFICATION FOR THE INVENTION ENTITLED

"CLEANING DEVICES"

The following statement is a full description of the invention including the best method of performing it known to us:-

The invention relates to cleaning devices.

Cleaning devices are available, known as "sweep mops", which comprise a mop pad mounted on a pad holder attached to a handle so that the operative area of the pad
5 lies flat on the surface being mopped as the mop is used with a sweeping action. Such mops are in general use for the wet or damp mopping of large surface areas.

It is frequently desired to subject a surface to a wiping or polishing treatment using a similar sweeping
10 action, and paper or cloth "wipes" are commonly used attached to a broom-like or similar style holder. Paper or a similar material can wipe clean a surface without leaving smears.

The invention provides a cleaning device which
15 can be used as a sweep mop in a conventional wet or damp mopping operation or alternatively in a wiping or polishing operation, to this end a mop pad holder having attachment means for the mop pad and for the separate attachment of a sheet of wiping or polishing material. Thus a dual-purpose
20 cleaning device results which without a wiping/ polishing sheet attached can be used for wet/damp mopping or alternatively, with such a sheet attached, used for wiping or polishing of a surface.

The top wiping/polishing sheet used may, for
25 example, be a cloth or paper wipe which can be used in either a dry or a damp condition. In the latter case the mop pad may be wetted before the top sheet is separately

attached to provide a reservoir from which the sheet is continuously moistened as it is used. Alternatively, the mop pad may be removed and replaced by a a moisture retaining pad, of cotton or cellular sponge for example, which provides a reservoir for moistening the attached top sheet.

5

According to the invention the attachment means for the mop pad comprise slots or apertures adjacent the ends of the holder so that the latter presents end bars around which end tails of the pad can respectively be wrapped, these end portions having Velcro-type "hook and loop" surfaces so that they adhere to themselves. With end attachment slots and a collapsible holder the arrangement may be such that as the holder is erected not only does



this tension the pad but end sections of the holder press down on and thus maintain the Velcro attachments. In the case of larger apertures these may effectively be closed, after the pad is fitted, by hinged closure flaps which again press down on the Velcro attachments. The separate attachment means for the wiping/polishing sheet may be mounted on these closure flaps, or be provided by these flaps themselves which engage and hold down the ends of the wiping/polishing sheet.

10 The attachment means for the wiping/polishing sheet may be mounted as individual securing devices adjacent the four end corners of the pad holder so that a sheet can be wrapped around the underside of the holder and attached above the holder at the four corners. Whilst any suitable form of sheet attachment means may be employed, such means conveniently take the form of "push-in" fixings which comprise a cross-slotted resiliently flexible and membrane-like member through which the sheet can be pushed, whereupon the resilience of the member tends to close up the cross slots and the inserted sheet is gripped in a barb-like manner. The cross-slotted flexible members may be provided by attachment device units secured to the holder, or they may be moulded integrally with the latter.

25 The invention will now be further described with reference to the accompanying drawings which illustrate, by way of example, dual-purpose cleaning devices representing preferred embodiments of the invention. In the drawings:-

Fig. 1 is a side view of one embodiment, showing a collapsible pad holder thereof partially erected during the course of fitting a mop pad to the holder;

Fig. 2 is a side view with the holder fully erected;

5 Fig. 3 is a partial perspective view, from above, of one end of the holder;

Fig. 4 is a plan view of said end of the holder;

Fig. 5 is a cross-sectional view on the line V-V in Fig. 4;

10 Fig. 6 is an underneath perspective view of said end of the holder; and

Figs. 7 to 10 are views which correspond to that of Fig. 3 but are of another embodiment showing various states thereof.

15 The device illustrated in Figs. 1 to 6 comprises a collapsible pad holder 1 constructed with three relatively articulated sections - similar end sections 2 and 3 and a central section 4. A handle 5 of the desired length is attached by an articulatory handle mounting 6 mounted centrally on the top of the central section 4.

20 The pad holder 1 has attachment means for the attachment of a mop pad 7 comprising lateral through slots such as 8 moulded in the end sections 2,3, such slotting providing an end attachment bar such as 9. As can be seen
25 from Figs. 3 and 5, the mop pad 7 has end attachment tails such as 10 which are wrapped around the respective end attachment bars 9 of the end sections 2,3 of the holder 1.

The end tails 10 are provided with Velcro type "hook and loop" attachment surfaces so that, when the overlapped sections of a tail 10 are pressed together they attach one to the other. With the holder 1 at least partially collapsed, as in Fig. 1, the mop pad 7 can be attached by its end tails 10 in this manner.

After attachment of the end tails 10 to the end sections 2 and 3, the holder 1 is fully erected as shown in Fig. 2, to bring the end sections into alignment when latch means automatically engage to maintain the erected condition, in which the mop pad 7 is under longitudinal tension so that it is held firmly against the underside of the pad holder 1. The design of these latch means and the articulatory construction of the holder 1 may be of known form and, as they are not germane to the invention, they will not be described in further detail herein.

The holder 1 is of moulded plastics construction, and (referring particularly to Fig. 6) the end section mouldings 2 and 3 are of hollow shell form with a side wall such as 11, and internal longitudinal strengthening webs 12 joined to a wall 13 which surrounds the slot 8. As can be seen from Fig. 5, in the erected condition the inner side edge 14 of the wall 13 at each end of the holder 1 presses against the overlapped sections of the corresponding end tail 10 of the mop pad 7. This holds the overlapped sections, with the Velcro engagement, firmly together.

For use with a paper "wipe", or other desired

wiping/polishing sheet material, the sheet of such material is wrapped over the erected holder 1 and mop pad 7 so as to cover the operative surface of the latter. It is secured in position by separate and independent attachment means comprising, adjacent the four corners of the holder 1, individual "push in" securing devices 15. The devices 15 may be moulded integrally with the end sections 2,3 or separately formed and mounted thereon, for example secured thereto by adhesive. Each device 15 comprises a flexible resilient membrane 16 with a cross slot 17 through which a corner of the wiping/polishing sheet can be inserted so as to be gripped resiliently by the membrane 16 as the resilience thereof tends to close up the cross slot 17. Furthermore, due to having been pushed in at the slot 17, the flexed membrane engages the attached sheet (not shown) with a barb-like gripping action so that the sheet is securely attached.

Fig. 4 shows, in respect of the two sheet attachment devices 15 illustrated therein, alternative forms of the cross slot 17 which might be used in this embodiment. It will be appreciated that in practice one or other of these would be selected, all four devices 15 being identical.

The device of Figs. 7 to 10 is similar to that of the earlier figures except for the outer ends of the end sections one of which, referenced 20, is partially shown in overhead perspective in these later figures. As before the

end section 20 has an end attachment bar 21, this now being defined not by a transverse slot but by a moulded-in rectangular through aperture 22. The aperture 22 is normally filled by a hinged closure flap 23 which pivots about a lateral axis at the inner end of the aperture 22. The flap 23 is spring loaded about the hinge axis towards the normal closed position illustrated in Fig. 7.

As before, the end bars such as 21 provide attachment means for a mop pad 24. To attach the pad 24 the closure flaps such as 23 are lifted to the position shown in Fig. 8, allowing the end tails such as 25 of the pad 24 to be wrapped around the end bars and the overlapped portions thereof fastened to each other as illustrated in Fig. 9. The flaps such as 23 are then released, so as to move under the spring loading to the closed position as illustrated in Fig. 10 when they press down on the respective end tails 25. Each flap 23 is a hollow moulding with a side wall 26 which, at the outer side of the flap, has a bottom edge 27 which engages and holds down the corresponding end tail 25 in the same manner as the edge 14 of the wall 13 in the earlier embodiment.

The separate and independent attachment means of the invention, for attachment of a wiping/polishing sheet are again provided by four "push-in" securing devices 28. Thus each of the devices 28 comprises a flexible resilient membrane 29 with a cross slot 30, and they are respectively disposed adjacent the four corners of the holder. The

devices 28 are mounted on the closure flaps 23.

It will also be appreciated from the foregoing description that the invention provides a dual-purpose cleaning device usable, alternatively, as a normal sweep mop for wet or damp mopping or, with an attached covering sheet (with or without a mop pad attached beneath it), for wiping or polishing according to the nature of the attached sheet. Furthermore, the attached sheet can be kept continuously moistened, should this be desired, by attaching and wetting the mop pad 7 before the top sheet is separately attached over it by means of the attachment devices 15. The wiping/polishing sheet may be of any desired material, typically of paper, paper-like, cotton or synthetic fibrous material, woven or non-woven. When used over a wetted mop pad it may be of a porous nature such that a controlled flow of moisture maintains its outer surface just slightly moistened to provide a "damp wipe" condition.

The claims defining the invention are as follows:-

1. A cleaning device alternatively usable as a sweep mop in a conventional wet or damp mopping operation, or in a wiping or polishing operation, comprising a mop pad holder having attachment means for the mop pad and for the separate attachment of a sheet of wiping or polishing material, and wherein the attachment means for the mop pad comprise slots or apertures adjacent the ends of the holder so that the latter presents end bars around which end tails of the pad can respectively be wrapped, these end portions having complementary "hook and loop" type surfaces so that they adhere to themselves.

2. A cleaning device according to claim 1, wherein the holder is of articulatory collapsible construction and the arrangement is such that as the holder is erected this tensions the pad and end sections of the holder press down on and thus maintain the hook and loop type attachments of the mop pad.

3. A cleaning device according to claim 1, wherein said apertures adjacent the ends of the holder are effectively closed, after the mop pad is fitted, by hinged closure flaps which press down on and thus maintain the "hook and loop" type attachments of the mop pad.



4. A cleaning device according to claim 3, wherein the attachment means for the wiping/polishing sheet are provided on said closure flaps.

5. A cleaning device according to claim 3, wherein the attachment means for the wiping/polishing sheet are provided by said closure flaps which engage and hold down the ends of the wiping/polishing sheet.

6. A cleaning device according to any one of claims 1 to 4, wherein the attachment means for the wiping/polishing sheet are provided as individual securing devices adjacent the four end corners of the pad holder so that a sheet can be wrapped around the underside of the holder and attached above the holder at the four corners.

7. A cleaning device according to claim 6, wherein the sheet attachment means take the form of "push-in" fixings which each comprise a cross-slotted resiliently flexible and membrane-like member through which the sheet can be pushed, whereupon the resilience of the member tends to close up the cross slots and the inserted sheet is gripped in a barb-like manner.

8. A cleaning device according to claims 4 and 7, wherein the cross-slotted flexible members of the securing devices are moulded integrally with the closure flaps.



9. A cleaning device which is constructed and arranged substantially as herein particularly described with reference to Figs. 1 to 6, or Figs. 7 to 10, of the accompanying drawings.

DATED this 4th day of March, 1991.

SCOT YOUNG RESEARCH LIMITED
By its Patent Attorneys
PETER MAXWELL & ASSOCIATES



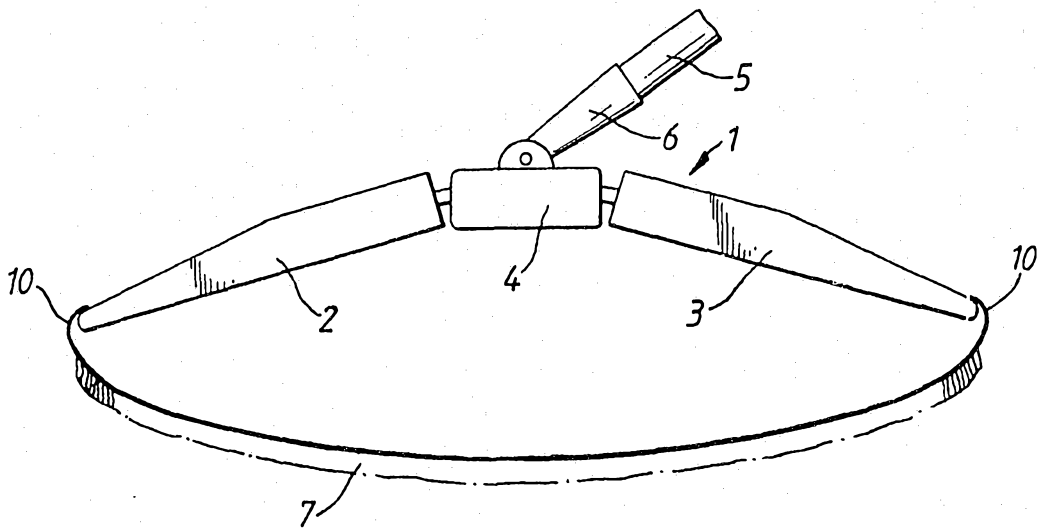

Fig. 1.

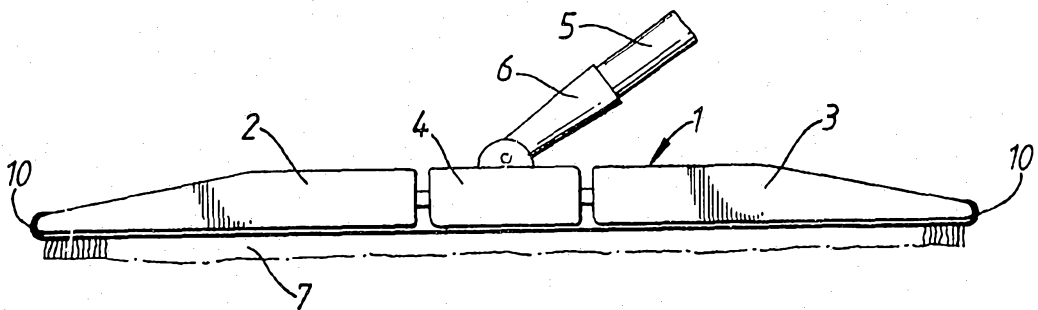

Fig. 2.

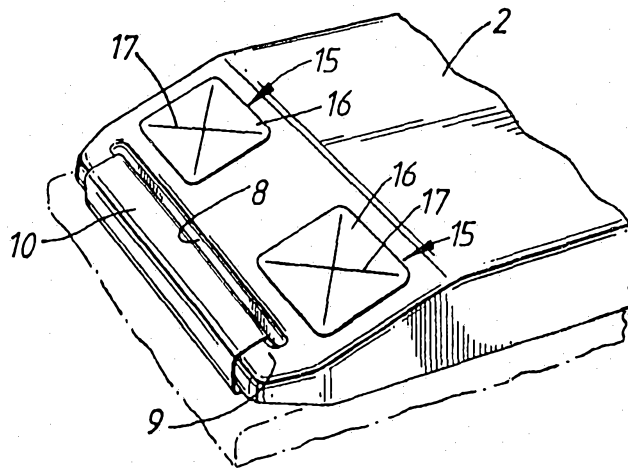
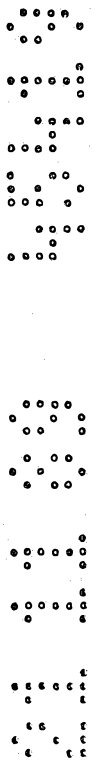

Fig. 3.



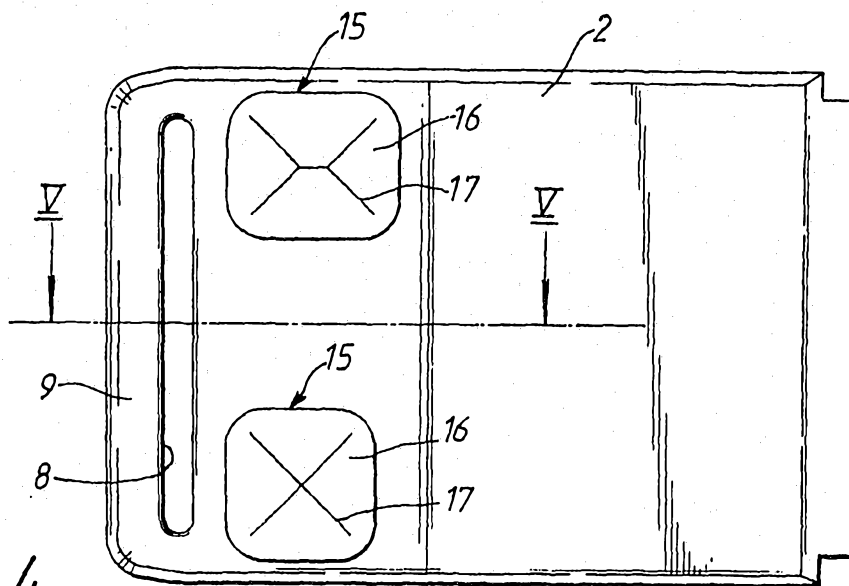

Fig. 4.

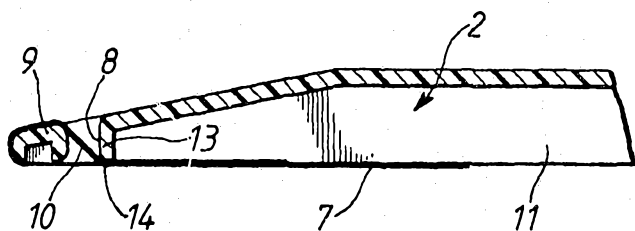

Fig. 5.

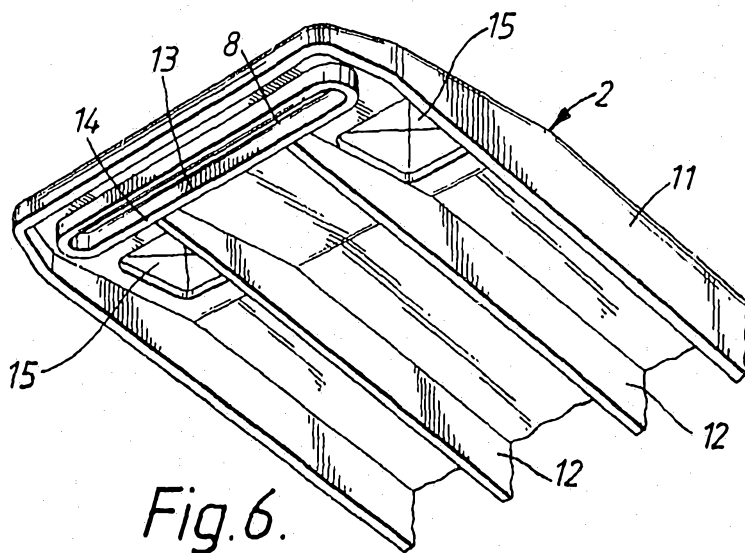

Fig. 6.

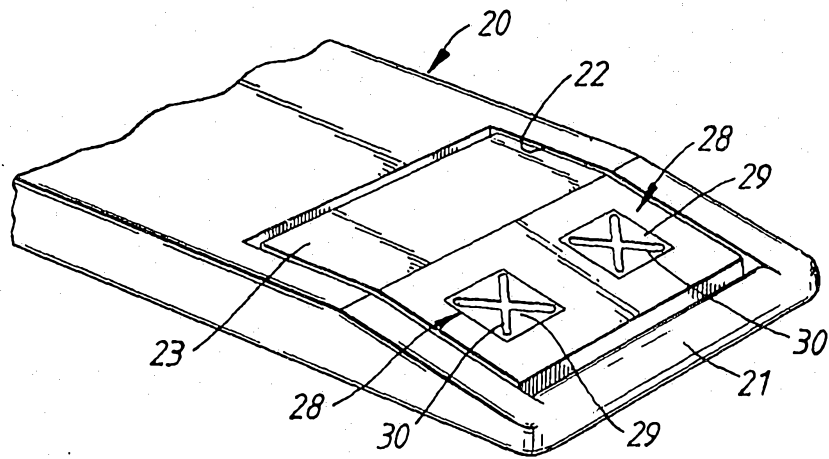

Fig. 7.

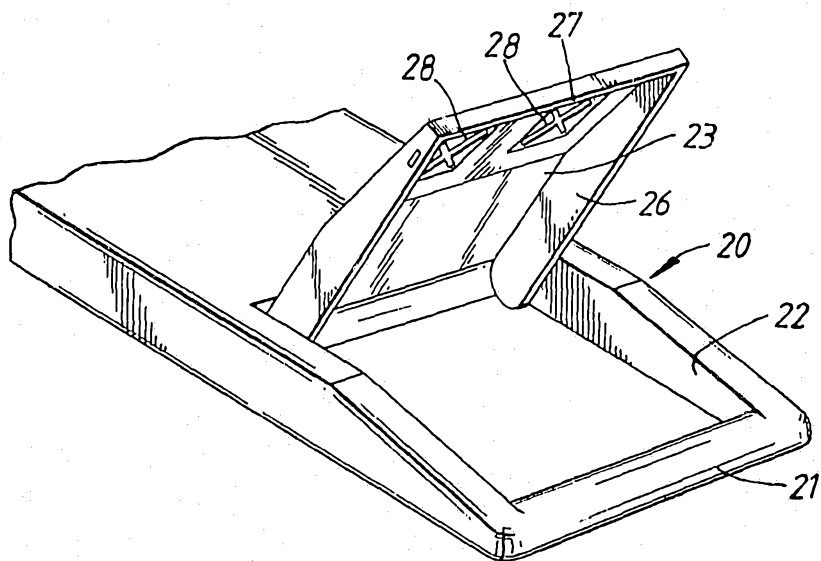

Fig. 8.

45419/89

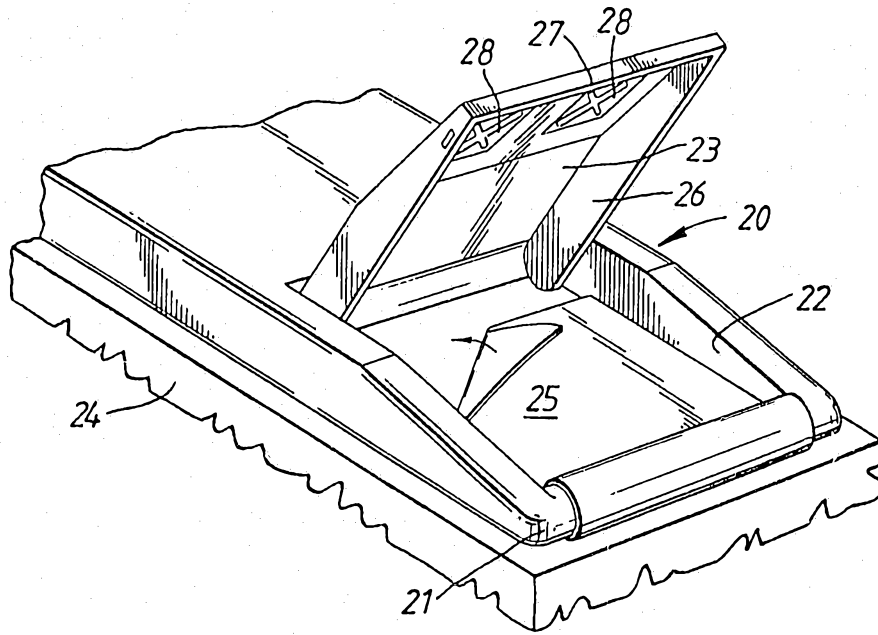

Fig. 9.

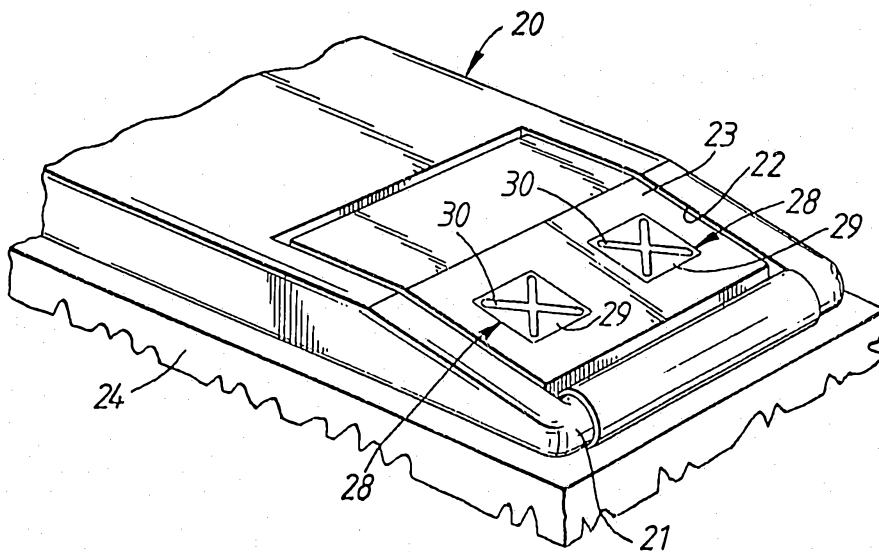

Fig. 10.