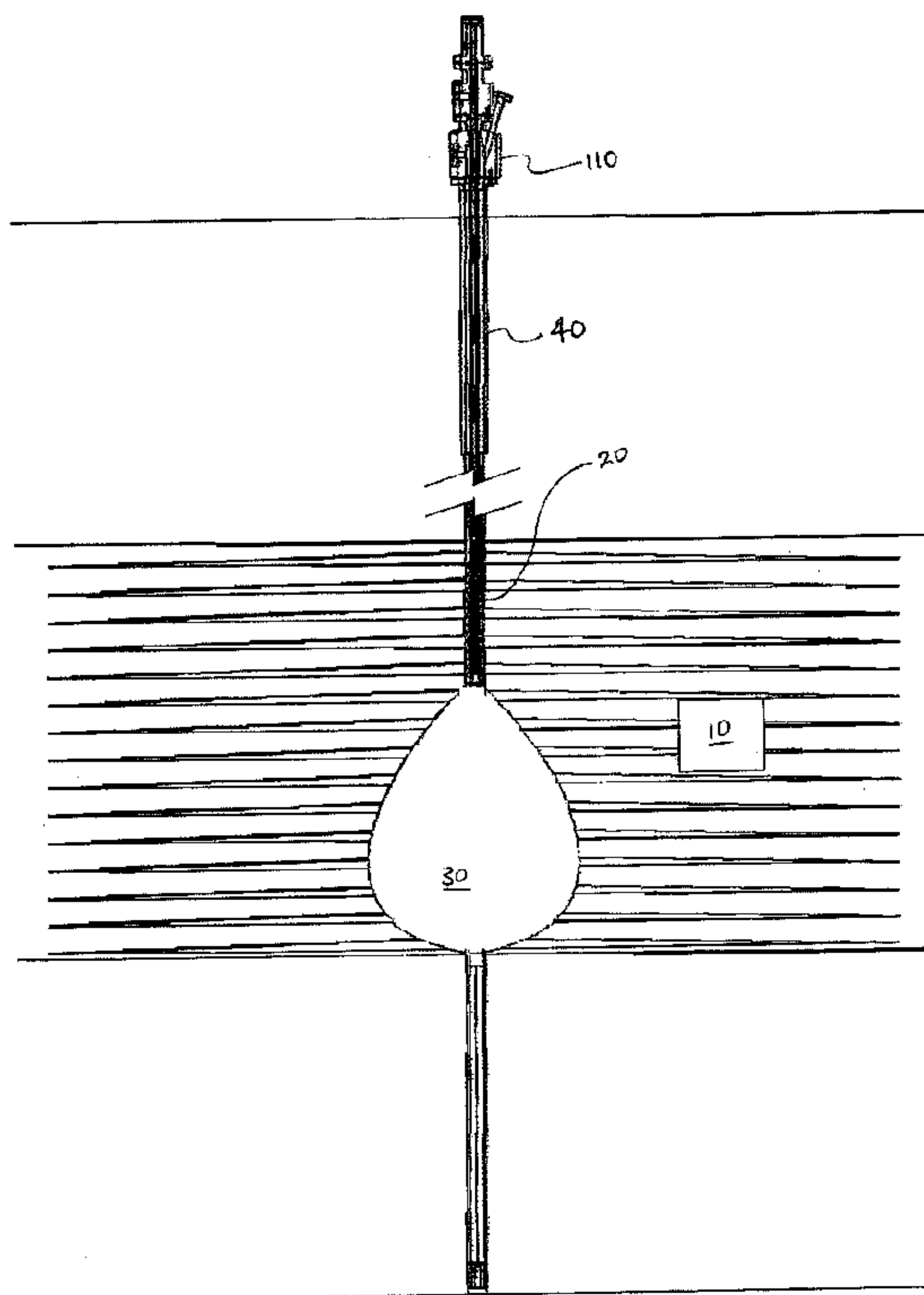




(22) Date de dépôt/Filing Date: 2010/01/14  
 (41) Mise à la disp. pub./Open to Public Insp.: 2010/07/16  
 (45) Date de délivrance/Issue Date: 2014/08/19  
 (30) Priorité/Priority: 2009/01/16 (US61/145,501)

(51) Cl.Int./Int.Cl. *E21B 43/243* (2006.01),  
*E21B 43/10* (2006.01), *E21B 43/16* (2006.01)  
 (72) Inventeurs/Inventors:  
SCHNEIDER, FRED, CA;  
TESSIER, LYNN P., CA  
 (73) Propriétaire/Owner:  
RESOURCE INNOVATIONS INC., CA  
 (74) Agent: GOODWIN MCKAY

(54) Titre : APPAREILLAGE ET METHODE DE PRODUCTION DE VAPEUR DE FOND ET D'EXTRACTION  
PETROLIERE AMELIOREE  
 (54) Title: APPARATUS AND METHOD FOR DOWNHOLE STEAM GENERATION AND ENHANCED OIL RECOVERY



(57) Abrégé/Abstract:

A burner with a casing seal is used to create a combustion cavity at a temperature sufficient to reservoir sand. The burner creates and sustains hot combustion gases at a steady state for flowing into and permeating through a target zone. The casing seal isolates the combustion cavity from the cased wellbore and forms a sealed casing annulus between the cased wellbore and the burner. Water is injected into the target zone, above the combustion cavity, through the sealed casing annulus. The injected water permeates laterally and cools the reservoir adjacent the wellbore, and the wellbore from the heat of the hot combustion gases. The hot combustion gases and the water in the reservoir interact to form a drive front in a hydrocarbon reservoir.

ABSTRACT

1  
2  
3  
4  
5  
6  
7  
8  
9  
10  
11  
12  
13

A burner with a casing seal is used to create a combustion cavity at a temperature sufficient to reservoir sand. The burner creates and sustains hot combustion gases at a steady state for flowing into and permeating through a target zone. The casing seal isolates the combustion cavity from the cased wellbore and forms a sealed casing annulus between the cased wellbore and the burner. Water is injected into the target zone, above the combustion cavity, through the sealed casing annulus. The injected water permeates laterally and cools the reservoir adjacent the wellbore, and the wellbore from the heat of the hot combustion gases. The hot combustion gases and the water in the reservoir interact to form a drive front in a hydrocarbon reservoir.

1       **APPARATUS AND METHOD FOR DOWNHOLE STEAM GENERATION AND**  
2                                   **ENHANCED OIL RECOVERY**  
3

4  
5                                   FIELD OF THE INVENTION

6               The present invention relates to an apparatus and a method for  
7 creating a drive front for enhanced oil recovery. More specifically, a downhole  
8 burner first forms a combustion cavity in a hydrocarbon formation and then a  
9 combination of steady state combustion and water injection above the cavity creates  
10 a steam and gas drive front in the hydrocarbon formation.  
11

12                                   BACKGROUND OF THE INVENTION

13               It is known to conduct enhanced oil recovery (EOR) of hydrocarbons  
14 from subterranean hydrocarbon formations after primary recovery processes are no  
15 longer feasible. EOR include thermal methods such as in-situ combustion, steam  
16 flood, and miscible flooding which use various arrangements of stimulation or  
17 injection wells and production wells. In some techniques the stimulation and  
18 production wells may serve both duties. Other techniques include steam flooding,  
19 cyclic steam stimulation (CSS), in-situ combustion and steam assisted gravity  
20 drainage (SAGD). SAGD uses closely coupled, a horizontally-extending steam  
21 injection well forming a steam chamber for mobilizing heavy oil for recovery at a  
22 substantially parallel and horizontally-extending production well.

23               Thermal methods of EOR can only be implemented in wells that have  
24 been completed for thermal completions. Due to the high temperatures used in

1 thermal completions, wells employing such EOR techniques must be completed  
2 using materials, such as steel and cement, that can withstand high temperatures.  
3 Wells that were not completed with such high temperature resistant materials cannot  
4 implement thermal completions for EOR. Accordingly, well operators must decide  
5 on whether or not to implement of thermal EOR and based on this decision complete  
6 a well using (or not) high temperature resistant materials.

7 US 3,196,945 to Forrest et al (assigned to Pan American Petroleum  
8 Company) discloses a downhole process comprising a first igniting a reservoir and  
9 then injecting air or an equivalent oxygen containing gas in an amount sufficient to  
10 create a definite combustion zone or front, the front being at high temperature,  
11 typically 800 - 2400° F. Called forward combustion, Forrest contemplates an oxygen  
12 rich front for continued combustion. Demands for large air flow is reduced by co-  
13 injection of water or other suitable condensable fluid into the heated formation to  
14 create steam front that urges the movement of hydrocarbons or oil. Forrest can co-  
15 discharge water and air to the heated formation for creating high temperature steam.

16 US 4,442,898 to Wyatt (assigned to Trans-Texas Energy Inc.)  
17 discloses a downhole vapor generator or burner. High pressure water in an annular  
18 sleeve around the burner combustion chamber within which an oxidant and fuel are  
19 combusted. The energy from the combustion vaporizes the water surrounding the  
20 combustion chamber, cooling the burner and also creating high temperature steam  
21 for injection into the formation.

22 US 4,377,205 to Retallick discloses a catalytic low pressure combustor  
23 for generating steam downhole. The steam produced from the metal catalytic



1 supports is conducted to steam generating tubes, and the steam is injected into the  
2 formation. Any combustion gases produced are vented to the surface.

3 US 4,336,839 to Wagner et al (assigned to Rockwell International  
4 corp.) discloses a direct firing downhole steam generator comprising an injector  
5 assembly axially connected with a combustion chamber. The combustion products,  
6 including CO<sub>2</sub>, are passed through a heat exchanger where they mix with pre-heated  
7 water and are ejected out of the generator into the formation through a nozzle.

8 US 4,648,835 to Eisenhower et al. (assigned to Enhanced Energy  
9 Systems) discloses a direct fire steam generator comprising a downhole burner  
10 employing a unique ignition technique using the gaseous injection of a pyrophoric  
11 compound such as triethylborane. Natural gas is burned and water is introduced to  
12 control combustion. The combustion products, like in Wagner are mixed with water  
13 and the resulting steam and other remaining combustion products are injected into  
14 the formation.

15 US Patent Application Publication 2007/0193748 to Ware et al  
16 (assigned to World Energy Systems, Inc.) discloses a downhole burner for producing  
17 hydrocarbons from a heavy-oil formation. Hydrogen, oxygen and steam are pumped  
18 by separate conduits to the burner. A portion of the hydrogen is combusted and the  
19 burner forces the combustion products out into the formation. Incomplete  
20 combustion is useful in suppressing the formation of coke. The injected steam cools  
21 the burner, thereby creating a super heated steam which is also injected into the  
22 formation along with the combustion products. CO<sub>2</sub> from the surface is also pumped

1 downhole for heating and injection into the formation to solubilise in oil for reducing  
2 its viscosity.

3 In-situ processes to date have not successfully provided economic  
4 solutions and have not resolved issues of temperature management, corrosion,  
5 coking and overhead associated with existing surface equipment.

6

7

### SUMMARY OF THE INVENTION

8 The present invention is an apparatus and method of creating a drive  
9 front in a hydrocarbon reservoir. The apparatus is positioned in a cased wellbore  
10 within a target zone in the hydrocarbon reservoir. The apparatus comprises a  
11 downhole burner fluidly connected to a tubing string extending downhole. The  
12 tubing string comprises a plurality of passages for at least fuel, and oxidant and  
13 water. The downhole burner creates a combustion cavity within the target reservoir  
14 zone by combusting the fuel and the oxidant, such as oxygen, at a temperature  
15 sufficient to melt the reservoir at the target zone or otherwise form a cavity below the  
16 downhole burner. Once the combustion cavity is created, the downhole burner  
17 operates at steady state for creating and sustaining hot combustion gases in the  
18 combustion cavity, which flow or permeate into the hydrocarbon reservoir. The hot  
19 combustion gases permeate away from the combustion cavity forming a gaseous  
20 drive front, transferring some of its heat to the rest of the reservoir.

21 Water is also injected into the target zone above the combustion  
22 cavity, which flow or permeate laterally into the reservoir adjacent the wellbore. In  
23 the reservoir, the water acts to cool the reservoir adjacent the wellbore, decreasing

1 the amount of heat lost to the overburden. At an interface, the water and hot  
2 combustion gases combine to create a steam and gaseous drive front.

3 Further, the injection of water adjacent the wellbore also cools the  
4 cased wellbore, protecting the casing against the heat from the steam and hot  
5 combustion gases. Accordingly, the present invention is not limited to use only in  
6 thermally completed wells and can be implemented at any cased wellbore, whether  
7 or not the wellbore was completed for thermal EOR.

8 In a broad aspect of the invention, a process for creating a steam and  
9 gas drive front is disclosed. A downhole burner assembly, fluidly connected to a  
10 main tubing string, is positioned within a target zone in a hydrocarbon reservoir. The  
11 burner assembly creates a combustion cavity by combusting fuel and an oxidant at a  
12 temperature sufficient to melt the reservoir or otherwise create a cavity. The burner  
13 assembly then continues steady state combustion to create and sustain hot  
14 combustion gases for flowing and permeating into the reservoir for creating a  
15 gaseous drive front. Water is injected into the reservoir, uphole of the combustion  
16 cavity for creating a steam drive front.

17 In another broad aspect of the invention, a downhole steam generator  
18 for enhanced oil recovery from a hydrocarbon reservoir accessed by a cased and  
19 completed wellbore is disclosed. The downhole steam generator is a burner  
20 assembly positioned within the cased wellbore at the hydrocarbon reservoir, the  
21 burner assembly having a high temperature casing seal adapted for sealing a casing  
22 annulus between the downhole burner and the cased wellbore, and a means for  
23 injecting water into the hydrocarbon reservoir above the casing seal. The high



1 temperature casing seal can pass through casing distortions, and is reusable, not  
2 being affected substantially by thermal cycling.

3 In another broad aspect of the invention, a system for creating a drive  
4 front in a hydrocarbon reservoir having a cased wellbore is disclosed. The system  
5 has a burner assembly having a downhole burner and a high temperature casing  
6 seal for sealing a casing annulus between the downhole burner and the casing of  
7 the cased wellbore. The high temperature casing seal can pass through casing  
8 distortions and is reusable, substantially not being affected by thermal cycling.

9 In another broad aspect of the invention, a system is provided for  
10 fluidly connecting three concentric passageways in a main tubing string to a  
11 downhole tool. The system has an outer housing, an intermediate mandrel and an  
12 inner mandrel. The outer housing is releaseably connected to the intermediate  
13 mandrel by an intermediate latch assembly and similarly, the inner mandrel is  
14 releaseably connected to the intermediate mandrel by an inner latch assembly. The  
15 intermediate mandrel is fit within the outer housing, forming an intermediate annulus  
16 therebetween, and is adapted to fluidly connect to an intermediate tubing string. The  
17 inner mandrel is fit within the intermediate mandrel, forming an inner annulus  
18 therebetween and is adapted to fluidly connect to an inner tubing string. The inner  
19 mandrel further has an inner bore.

20

## 21 BRIEF DESCRIPTION OF THE FIGURES

22 Figure 1 is a side cross-sectional view of an embodiment of the  
23 present invention, illustrating a combustion cavity in a hydrocarbon reservoir, the



1 cavity being created by downhole burner and formed for disseminating hot  
2 combustion gases for forming a gaseous drive front and interacting with water  
3 injected uphole of the cavity for forming an additional steam drive front;

4 Figure 2A is a side quarter-sectional view of a wellhead for supporting  
5 three tubing strings extending down a cased wellbore according to one embodiment  
6 of the present invention;

7 Figure 2B is a side quarter-sectional elevation of the three tubing  
8 strings of Fig. 2A (casing omitted) and illustrating a main tubing string supporting  
9 the downhole burner at a burner interface assembly, the main tubing string having  
10 an intermediate and an inner tubing string disposed therein;

11 Figure 3 illustrates a quarter-sectional, perspective view across the  
12 casing and three concentric tubing strings;

13 Figure 4 is a side quarter-sectional view of an embodiment of a  
14 downhole burner sealed at a downhole end to a casing for fluidly connecting a  
15 casing annulus and the reservoir through perforations;

16 Figure 5 is a side, quarter-sectional view of the burner of Fig. 3 with the  
17 casing omitted, and illustrating the fuel passageway, the oxygen passageway and  
18 the nozzle;

19 Figure 6 is a side, quarter-sectional view of the burner of Fig. 3 with the  
20 casing and oxygen passageway omitted for illustrating the casing seal and an  
21 embodiment of fuel passageway swirl vanes;

22 Figure 7A is a partial cross-sectional view of the nozzle and an  
23 embodiment of a brush-type casing seal of Fig. 3 with the casing omitted;

1           Figure 7B illustrates an activated brush seal according to Fig. 7A and  
2 showing the stack of flexible brush rings flexing when constrained by the casing;

3           Figure 8 is a overhead plan view of one concentric brush ring of a  
4 stack of concentric brush rings of a brush seal and an arrangement of spiral slits and  
5 fingers;

6           Figure 9 is a perspective view of two brush rings of the stack of  
7 concentric brush rings according to Fig. 8 illustrating a rotational offsetting of the  
8 spiral slits for forming a tortuous, restrictive fluid path therethrough;

9           Figure 10 is a schematic representation a main tubing string, an  
10 intermediate tubing latched within the bore of the main tubing string, and an inner  
11 tubing latched and terminated within the bore of the intermediate tubing, three fluid  
12 passageways created therein, the inner annulus being terminated at the  
13 intermediate mandrel;

14           Figure 11 is a cross-sectional view of the burner interface assembly  
15 illustrating the outer housing, the intermediate and inner mandrels, the intermediate  
16 and inner latch assemblies, and the backpressure valve assembly;

17           Figure 12 is a side quarter-sectional view of an uphole end of the  
18 intermediate mandrel for illustrating termination of the inner and intermediate tubing  
19 and the inner mandrel having an inner tubing latch;

20           Figure 13 is a quarter-sectional and elevation view of a step of the  
21 running in of an embodiment of the apparatus of the invention, more particularly  
22 illustrating the main tubing hanger, and downhole adjacent the reservoir, a torque  
23 anchor, outer housing, pup joint, burner housing, burner nozzle and casing seal;

1           Figure 14A is a quarter-sectional and elevation view of a further step  
2 according to Fig. 13, more particularly illustrating the insertion of the intermediate  
3 tubing string, hanging the tubing from an intermediate tubing hanger, latching of the  
4 intermediate mandrel and positioning of the oxygen passageway within the burner  
5 housing;

6           Figure 14B is a closeup of the burner interface assembly of Fig. 14A  
7 for illustrating the intermediate tubing, the intermediate mandrel and the oxygen  
8 passageway;

9           Figure 15A is a quarter-sectional and elevation view of a further step  
10 according to Fig. 13, more particularly illustrating the insertion of the inner tubing  
11 string, hanging the inner tubing from an inner tubing hanger, latching of the inner  
12 mandrel; and

13           Figure 15B is a closeup of the burner interface assembly of Fig. 15A  
14 for illustrating the hanging the inner tubing from the inner tubing hanger, the inner  
15 tubing and the inner mandrel.

16

## 17           DETAILED DESCRIPTION OF THE INVENTION

18           As shown in Fig. 1, a thermal process utilizes a downhole production of  
19 heat, steam and hot combustion gases (primarily CO, CO<sub>2</sub>, and H<sub>2</sub>O) to best effect  
20 for the recovery of residual or otherwise intractable hydrocarbons from a  
21 hydrocarbon reservoir 10. A burner assembly 20 initially creates a combustion  
22 cavity 30 and then creates and sustains the creation of hot combustion gases, such  
23 as CO, CO<sub>2</sub>, and H<sub>2</sub>O. Addition of water to the reservoir 10 above the combustion



1 cavity 30 results in the production of a steam drive front. The steam and hot  
2 combustion gases combine to create a steam and gaseous drive front.

3           With further reference to Figs. 1, 2B, 3, 4 and 13, apparatus for  
4 implementing such a process comprises a burner assembly 20 at a downhole end of  
5 a main tubing string 40 and one or more additional tubing strings. The main tubing  
6 string 40 and other tubing strings form a plurality of discrete fluid passageways for  
7 supplying the burner assembly 20. As shown in Fig. 4, the downhole burner 60 is  
8 terminated in an existing cased wellbore adjacent casing perforations accessing the  
9 reservoir 10. The burner assembly 20 can comprise a burner interface assembly 50  
10 for fluidly connecting to the tubing strings, a downhole burner 60, and a casing seal  
11 70 for sealing a casing annulus 80 between the downhole burner 60 and a casing 90  
12 of the cased wellbore. The casing annulus 80 is yet another passageway used for  
13 directing water from the casing annulus 80 to the reservoir 10.

14           As shown in Figs. 2A to 4, one approach is to suspend the burner  
15 assembly 20 from a conventional sectional tubing string supported by a conventional  
16 tubing hanger 100 on a wellhead 110. The casing annulus 80 is formed between the  
17 casing 90 of the wellbore and the main tubing string 40 and extends to the annular  
18 space between the casing 90 of the wellbore and the burner assembly 20.

19           An intermediate tubing string 120 having an intermediate bore, such as  
20 an intermediate coil tubing string, is supported by an intermediate tubing hanger 130  
21 on the wellhead 110 and disposed within a bore of the main tubing string 40. An  
22 intermediate annulus 140 is formed between the main tubing string 40 and the  
23 intermediate tubing string 120.

1           An inner tubing string 150, such as an inner coil tubing string, is  
2 supported by an inner tubing hanger 160 on the wellhead 110 and is further  
3 disposed within the intermediate bore of the intermediate tubing string 120, forming  
4 a inner annulus 170 therebetween. The inner tubing string 150 further has an inner  
5 bore 180.

6           The wellhead 110 and tubing hangers 100, 130, 160 can be any  
7 appropriate wellhead and tubing hangers that are commonly available in the  
8 industry, such as the thermal wellhead and tubing hangers commercially available  
9 from StreamFlo Industries, Ltd., located at Edmonton, Alberta, Canada. The casing  
10 annulus 80, the intermediate annulus 140, inner annulus 170, and the inner bore 180  
11 all define discrete passageways for supplying the burner assembly 20.

12           The casing 90 of the cased wellbore, main tubing string 40, the  
13 intermediate tubing string 120 and the inner tubing string 150, creating the four  
14 discrete passageways, terminate at the burner interface assembly 50. The casing  
15 annulus 80 terminates at the downhole burner 60 for communication with the  
16 reservoir 10. The inner annulus 170 terminates at the burner interface assembly 50.  
17 The two remaining discrete passageways, the intermediate annulus 140, and inner  
18 bore 180, all connect or terminate at the downhole burner 60.

19           In one embodiment, the downhole burner 60 implements at least two  
20 fluid passageways for conducting fuel and oxidant for combustion. The oxidant is a  
21 source of oxygen, conventionally air, or more concentrated source such as a purified  
22 stream of oxygen. In a preferred embodiment, purified oxygen is used as the

1 oxidant instead of conventional air, as conventional air produces combustion gases  
2 having a substantial amount of gaseous nitrogen products.

3 The burner interface assembly 50 fluidly connects two of the discrete  
4 passageways to two fluid passageways of the downhole burner 60. In one  
5 arrangement, a third discrete passageway can be utilized as an isolating  
6 passageway between the fuel and the oxygen for sensing or detecting leaks in the  
7 discrete passageways for the fuel and oxygen..

8 The downhole burner 60 comprises a burner housing 190 having a  
9 downhole portion 200 for the mixing of fuel and oxygen. The burner housing 190  
10 supports a high temperature casing seal 70 for sealing the casing annulus 80 from  
11 the combustion cavity 30. The sealed casing annulus 80 can be used to fluidly  
12 communicate water down to the target zone, which is then injected into the reservoir  
13 10 for creating steam within the target zone, above the combustion cavity 30.

14 With reference to Figs. 2A, 2B, and 3, one embodiment of the present  
15 invention comprises the burner assembly 20 fluidly connected to the main tubing  
16 string 40. A downhole burner 60 is positioned at a downhole portion of a cased  
17 portion of an injection well, the casing 90 being perforated into the reservoir 10. The  
18 main tubing string 40 extends downhole and has conduits or passageways for  
19 conducting or transporting each of fuel, and oxygen, to the downhole burner 60. For  
20 ease of installation, intermediate and inner tubing strings 120, 150 are releasably  
21 connected to the burner assembly 20.



1           The downhole components, or as part of the burner assembly 20, can  
2 further comprise a torque anchor 210 to set the main tubing string 40 in the casing  
3 90.

4           In greater detail, and with reference to Figs. 3 to 6, the burner housing  
5 190 is adapted at an uphole portion 220 for fluid communication with the  
6 intermediate annulus 140 and inner bore 180. In one embodiment, the burner  
7 housing 190 is fluidly connected to the intermediate annulus 140 and the inner bore  
8 180 through the burner interface assembly 50. The burner housing 190 comprises  
9 two fluid passageways for fluidly communicating the fuel and oxygen.

10           As best shown in Figs. 5 and 6, the burner housing 190 comprises the  
11 downhole portion or burner nozzle 200 for combustion of the fuel and oxygen and an  
12 uphole portion 220 defining the two fluid passageways for fluidly communicating the  
13 fuel and oxygen to the nozzle 200. The uphole portion 220 has a bore 230 and a  
14 concentric conduit or tubing 240 extending therethrough for creating the two fluid  
15 passageways. A fuel passageway 250 is defined by the annular space formed  
16 between the bore 230 and the concentric conduit 240. The concentric conduit 240  
17 further has a bore defining an oxygen passageway 260.

18           The fuel passageway 250 is adapted to fluidly communicate with the  
19 intermediate annulus 140, communicating fuel from the surface to the nozzle 200.  
20 The bore 230 of the burner housing 190 and the fuel passageway 250 open into the  
21 nozzle 200 for injecting the fuel into the nozzle 200. The fuel passageway 250 can  
22 further have fuel swirl vanes 270 for aiding in the mixing of the fuel and oxygen.

1           The oxygen passageway 260 is in fluid communication with the inner  
2 bore 180, communicating oxygen from the surface to the nozzle 200. The oxygen  
3 passageway 260 has an opening 280 at a downhole end for injecting oxygen into the  
4 nozzle 200. The oxygen passageway 260 can further have oxygen swirl vanes (not  
5 shown) for aiding in the mixing of the fuel and oxygen. The oxygen and fuel mix for  
6 combustion at the nozzle 200.

7           With reference to Fig. 5, as stated above, the fuel passageway 250  
8 can further have fuel swirl vanes 270 for imparting a rotation to the fuel being  
9 injected into the nozzle 200. The oxygen passageway 260 can also have oxygen  
10 swirl vanes for imparting a rotation, counter to the direction of the rotation of the fuel,  
11 for maximizing the mixing of the fuel and oxygen for increasing the efficiency of the  
12 combustion of the fuel and oxygen. In a preferred embodiment, the ratio of swirl  
13 velocity to axial flow velocity of either the fuel or oxygen is substantially 1:2.

14           In an alternate embodiment, the opening 280 of the oxygen  
15 passageway 260 can be fitted with a bluff body (not shown) to reduce the axial  
16 momentum of the oxygen for stabilizing the combustion flame.

17           Further, in another alternate embodiment (not shown), the burner  
18 housing 190 can have two side-by-side bores extending therethrough for forming the  
19 fuel passageway and the oxygen passageway. Each bore can have an opening at a  
20 downhole end for injecting the fuel and oxygen into the nozzle 200 for combustion.

21           Conventional burner discharge arrangements can be employed  
22 including utilizing a plurality of orifices and concentric discharges. The nozzle 200  
23 can be any open ended tubular structure that allows mixing and combustion of the

1 fuel and oxygen. As shown, the nozzle 200 is a typical inverted truncated frusto-  
2 conical nozzle. The truncated apex is fluidly connected to the burner housing 190  
3 and the nozzle 200 extends radially outwardly towards a downhole end.

4 As shown in Figs. 4 and 6, the high temperature casing seal 70 can be  
5 located on the downhole burner 60 to isolate the casing annulus 80 from the  
6 combustion cavity 30. Accordingly, the casing seal 70 is generally located low on  
7 the downhole burner 60, such as between the downhole portion of the burner  
8 housing or nozzle 200 and the casing 90. In alternate embodiments (not shown),  
9 the casing seal 70 can be located between the uphole portion 220 of the burner housing  
10 190 and the casing 90.

11 Often, cased wellbores have casing distortions or kinks which  
12 introduce challenges to installation and tolerances for related seals to the casing.  
13 The casing distortions are an abrupt shifting of the casing axis resulting in a casing  
14 portion that is narrower than a nominal inner diameter of a typical casing. The  
15 passage of seals and other downhole tools are difficult at best if the nature of the  
16 seal is to initially comprise an outer diameter of seal which is larger than the inner  
17 diameter of casing and certainly greater than the distortion. Although downhole  
18 tools generally can be manufactured to have a small outer diameter to allow them to  
19 pass through a majority of distortions, seals generally can not. Seals having small  
20 outer diameter, although capable of passing through the distortions, are unlikely to  
21 fully seal against the casing downhole of the distortion where the casing again has a  
22 nominal inner diameter. Seals must also be able to withstand the extreme heat  
23 conditions created by a downhole burner when combusting the fuel and oxygen.



1           With reference to Figs. 6 to 9, an embodiment of the casing seal 70 is  
2 a brush-type seal comprising a plurality of flexible, concentric, metallic brush rings  
3 300 stacked one on top of another. As best shown in Figs. 6, 7A and 7B, the brush  
4 rings 300 are stacked one on top of another upon a circumferential stop shoulder  
5 310 at a downhole end of the nozzle 200. Spacer rings 320 can be provided to  
6 alternate between the brush rings 300. The stack of brush rings 300 and spacer  
7 rings 320 is secured in place by a compression ring 330 exerting an axial securing  
8 force to sandwich the rings 300, 320 to the stop shoulder 310. A compression nut  
9 340 secures the compression ring 330.

10           As shown in Figs. 8 and 9, each seal ring 300 has a multiplicity of slits  
11 350 that are formed radially inward from an outer circumference of the seal ring 300  
12 and which terminate before an inner diameter of the seal ring 300 for forming a  
13 plurality of flexible fingers 360. The fingers are separated at the outer circumference  
14 and connected at the inner diameter. An inner most radial extension of each slit 350  
15 defines the inner diameter of the multiplicity of slits 350 and is substantially the same  
16 as the outer diameter of the spacer rings 320. The plurality of fingers 360, flexing  
17 from the inner diameter, provide dimensional variability through flexibility for each  
18 concentric seal ring 300.

19           Each slit 350 extends radially outwardly in a generally clockwise  
20 direction as viewed looking downhole. This particular slit arrangement or design is  
21 advantageous when removing and pulling up the casing seal 70. In the event that  
22 the casing seal 70 becomes stuck, the clockwise slit arrangement allows the casing

1 seal to be rotated in a counter-clockwise direction, thus decreasing the outer  
2 diameter of the casing seal 70, and allowing it to dislodge from the casing 90.

3           As shown in Fig. 9, each seal ring 300 can be rotationally indexed  
4 relative to each adjacent seal ring 300. While enabling radial flexibility, the slits 350  
5 provide an avenue for fluids to leak therethrough. In order to minimize the amount of  
6 leaking of fluids through the slits 350, each seal ring 300 is rotated such that the slits  
7 350 of axially adjacent brush rings 300 are rotationally offset or misaligned. To  
8 further mitigate leakage through the slits 350, the plurality of concentric brush rings  
9 300 are stacked. Each finger 360 of one seal ring 300 overlaps each finger 360 of  
10 an adjacent seal ring 300, for forming a tortuous axial path for restricting flow of  
11 casing annulus fluids therethrough.

12           Referring back to Fig. 7A, the brush seal 70 has an outer diameter  
13 greater than a nominal inner diameter of a casing 90 in a cased wellbore as  
14 indicated by the dashed line. The greater outer diameter defines the effective  
15 sealing diameter of a particular brush seal. Brush-type seals having differing  
16 effective sealing diameters can be readily installed depending on the size of the  
17 casing 90 in the cased wellbore.

18           When the brush-type seal is run downhole, each finger 360 of each  
19 seal ring 300 flexes uphole, reducing the overall outer diameter and conforming to  
20 the casing 90, while maintaining the effective sealing diameter. The reduction of the  
21 overall outer diameter of the brush rings 300 allow the brush seal 70 to pass through  
22 a cased wellbore during installation and pass by most casing distortions. Upon

1 encountering a casing distortion, the ring fingers 360 of each concentric seal ring  
2 300 can elastically flex an additional amount to enable movement past the distortion.

3 In an alternate embodiment, other casing seals might be employed  
4 including a metallic inflatable packer, such as those now introduced by Baker Oil  
5 Tools, as presented in a paper entitled "Recent Metal-to-Metal Sealing Technology  
6 for Zonal Isolation Applications Demonstrates Potential for Use in Hostile HP/HT  
7 Environments", published as SPE 105854 in February 2007. Such inflatable  
8 packers are small enough in diameter to also pass through casing distortions and  
9 may be able to withstand the extreme heat conditions created by the burner.  
10 However, such packers can be damaged by thermal cycling and may not be  
11 reusable.

12 For example, in a 7 inch (178 mm) casing having an inner diameter of  
13 about 164 mm, a burner bottom hole assembly (BHA) fluidly connected to the  
14 downhole end of a 3-½ inch (89 mm) tubing, can be placed in a cased wellbore  
15 having the typical casing distortions. The burner BHA, comprising the burner  
16 interface assembly, pup joint, and downhole burner, had a total length of about 5  
17 feet (1524 mm). A 2-3/8 inch (60 mm) intermediate coil tubing was disposed within  
18 the 3-½ inch (89 mm) tubing, and a 1-¼ inch (32 mm) inner coil tubing was disposed  
19 within the intermediate coil tubing. The burner interface assembly was about 708  
20 mm long and had an outer diameter of about 114 mm, while the burner housing was  
21 about 304 mm long with an outer diameter of about 93 mm. The brush seal had an  
22 outer diameter of about 164 mm and was installed on a nozzle having a  
23 circumferential shoulder of about 120 mm. Each brush ring and spacer ring had a



1 thickness of about 0.25 mm. The pup joint, tailored to this particular example, was  
2 about 508 mm long and had an outer diameter of about 2-7/8 inches (73 mm).

3           With reference to Figs. 3 and 10, the fluid passageways can be formed  
4 by a series of tubing strings disposed in the bore of a larger tubing, or sectional  
5 tubing. Alternatively, two or more tubing strings might be arranged side-by-side (not  
6 shown). As shown in Fig. 3, the main tubing 40 is run down the cased wellbore  
7 forming the casing annulus 80 or a first casing annular fluid passageway  
8 therebetween. The intermediate tubing string 120 is disposed concentrically within  
9 the bore of the main tubing string 40, forming the intermediate annulus 140 or a  
10 second intermediate annular fluid passageway therebetween. The inner tubing  
11 string 150 is further disposed concentrically within the intermediate bore of the  
12 intermediate tubing string 120 forming the inner annulus 170 or a third inner annular  
13 fluid passageway therebetween. The bore of the inner tubing string 150 further  
14 defines the inner bore 180 or a fourth, inner bore fluid passageway.

15           Those skilled in the art would understand that although the  
16 intermediate tubing string 120 is concentrically disposed with the bore of the main  
17 tubing 40, the intermediate tubing string 120 may not remain concentrically aligned  
18 within the bore of the main tubing 40 as the intermediate tubing string 120 is run  
19 downhole. Similarly, the inner tubing string 150, although concentrically disposed in  
20 the intermediate bore of the intermediate tubing string 120 may not remain  
21 concentrically aligned as the inner tubing string 150 is run downhole.

22           In a basic form, two passageways are used for providing fuel and  
23 oxygen to the burner. A third passageway can be provided for isolating the fuel and

1 oxygen, and even more favourably for acting as a sensing passageway for  
2 determining development of a leak therebetween.

3           With reference to Figs. 10 to 12, in one embodiment, a burner interface  
4 assembly 50 fluidly connects three passageways of the main tubing 40 to the fuel  
5 and oxygen passageways 250, 260 of the downhole burner 60. The burner interface  
6 assembly 50 can comprise an outer housing 400 secured intermediate or at the  
7 downhole end of the main tubing string 40, an intermediate mandrel 410 at a  
8 downhole end of the intermediate tubing string 120, and an inner mandrel 420 at a  
9 downhole end of the inner tubing string 150.

10           The outer housing 400 has a bore which is adapted to releaseably  
11 connect with the intermediate mandrel 410. The intermediate mandrel 410 has an  
12 uphole portion 430 having a bore which is adapted to releaseably connect with the  
13 inner mandrel 420.

14           In greater detail, and with reference to Fig. 11, the outer housing 400  
15 has a bore, an uphole end 440 and a downhole end 450. The uphole end 440 is  
16 adapted to fluidly connect to the main tubing string (not shown) and the downhole  
17 end 450 is adapted to fluidly connect to a pup joint which supports the downhole  
18 burner (not shown).

19           With reference to Figs. 10 and 11, the intermediate mandrel 410 is fit  
20 within the bore of the outer housing 400 forming the intermediate annulus 140  
21 therebetween. The intermediate mandrel 410, releaseably connected to the outer  
22 housing 400 at an intermediate latch assembly 470, has an uphole portion 430  
23 which is adapted to fluidly connect to the intermediate tubing string 120. The uphole

1 portion 430 further has a bore for releaseably connecting to the inner mandrel 420.

2 In one embodiment, the uphole portion 430 is an inner latch housing.

3           The bore of the outer housing 400 has an inner surface 480 for forming  
4 a first intermediate latch 470A. The first intermediate latch 470A is formed adjacent  
5 a downhole end of the outer housing 400.

6           Further, the intermediate mandrel 410 has a second intermediate latch  
7 470B formed at its downhole end. The second intermediate latch 470B is adapted to  
8 releaseably connect to the complementary first intermediate latch 470A to form the  
9 intermediate latch assembly 470.

10           With reference to Figs. 10 and 12, the inner mandrel 420 is fit within  
11 the bore of the inner latch housing 430 and releasably connects with the  
12 intermediate mandrel 410 at an inner latch assembly 490. Similar to the  
13 intermediate latch assembly 470, the inner latch assembly 490 comprises a first  
14 inner latch 490A and a complementary second inner latch 490B.

15           As shown, the intermediate mandrel 410 is fit within the bore of the  
16 outer housing 400 for latching at the intermediate latch assembly 470 and sealing at  
17 a first seal 500 therebetween. The inner mandrel 420 is fit within the bore of the  
18 inner latch housing 430 for latching at the inner latch assembly 490 and sealing at a  
19 second seal 510 therebetween.

20           The intermediate annulus 140 is contiguous with an annular space  
21 between the outer housing 400 and the intermediate mandrel 410 and is in fluid  
22 communication with the fuel passageway 250 of the downhole burner 60. The inner  
23 bore 180 is contiguous with a bore of the inner mandrel 420 and is in fluid



1 communication with the oxygen passageway 260 of the downhole burner 60. In this  
2 embodiment, the inner annulus 170 happens to terminate sealably at the second  
3 seal 510 for isolating the intermediate annulus 140 from the inner bore 180.

4           The sealed inner annulus 170 isolates the intermediate annulus 140  
5 from the inner bore 180. This separation of the two discrete passageways provides  
6 a safety measure, ensuring that the fuel and the oxygen are separated by a buffer.  
7 In one embodiment, the sealed inner annulus 170 is also a sensing annulus for  
8 detecting leakage in the transport of the fuel and the oxygen. The sealed inner  
9 annulus 170 can be maintained in a vacuum or other pressure and is monitored for  
10 determining change in pressure indicative of a leak in either the intermediate  
11 annulus 140 or the inner bore 180.

12           The intermediate latch assembly 470 can be any suitable releasable  
13 latch used in the industry, but in a preferred embodiment, the intermediate latch  
14 assembly is a type of latch assembly disclosed and claimed in US Patent Serial  
15 Number 6,978,830, issued on December 27, 2005, to MSI Machineering Solutions,  
16 Inc., located in Providenciales, Turks and Caicos.

17           Similar to the intermediate latch assembly 470, the inner latch  
18 assembly 490 can be any suitable latch assembly used in the industry, including that  
19 disclosed and claimed in the aforementioned US Patent 6,978,830.

20           As best shown in Fig. 12, an uphole end of the inner latch housing 430  
21 is fit with a third seal 520 for sealing and isolating the intermediate annulus 140 from  
22 the inner annulus 170. The inner latch housing 430 further has a second seal 510  
23 for sealing and isolating the inner annulus 170 from the inner bore 180.

1           For redundancy purposes, and to ensure sealing and isolating of the  
2 three discrete passageways, the first, second, and third seals 500, 510, 520 can be  
3 a plurality of individual seals in a stacked arrangement.

4           For greater safety and control of the fuel and oxygen passageways,  
5 and in a particular embodiment, the intermediate mandrel 410 can further comprise  
6 a backpressure valve assembly 600 for controlling the flow of the fuel and oxygen.  
7 Fuel is forced from the intermediate annulus 140 through the backpressure valve  
8 assembly by the first seal 500.

9           The backpressure valve assembly 600 comprises two fluid bypass  
10 passageways, each having a backpressure valve. The fluid bypass passageways  
11 bypass the first seal 500. A first bypass passageway 610, having a first  
12 backpressure valve 620, is in fluid communication with the intermediate annulus 140  
13 for transporting the fuel from the main tubing string 40 to the fuel passageway 250 of  
14 the downhole burner 60. A second bypass passageway 630, having a second  
15 backpressure valve 640, is in fluid communication with the inner bore 180 for  
16 transporting the oxygen to the oxygen passageway 260 of the downhole burner 60.

17           Each of the backpressure valves comprises a ball 620A, 640A and a  
18 spring 620B, 640B, biased to apply a constant closing force on the ball, ensuring  
19 that the ball is sealingly fit within a ball seat 650A, 650B. The constant closing force  
20 is greater than the force applied by the differential fluid pressure between the static  
21 fluid pressure above the backpressure valves 620, 640 and a reservoir pressure  
22 below the backpressure valves 620, 640. For either the fuel and/or oxygen to flow  
23 pass the backpressure valves 620, 640, the injection pressure of the fuel or oxygen



1 must exert enough force to overcome the combined forces of the spring 620B, 640B  
2 and the reservoir pressure.

3 In one embodiment, the closing force biasing the ball of the  
4 backpressure valves 620, 640 is based upon a differential pressure of 200 psi. In  
5 this embodiment, the injection pressure of both the fuel and oxygen must be  
6 sufficient to exert sufficient pressure to overcome the combined forces of the closing  
7 force and the force exerted by the reservoir pressure.

8 The injection pressure of the fuel or oxygen does not exceed the  
9 fracturing pressure of the particular target zone.

10

#### 11 IN OPERATION

12 In one embodiment, a combustion chamber 30 is formed by melting a  
13 target zone at a temperature sufficient enough to melt the hydrocarbon reservoir 10  
14 at the target zone. Thereafter, a steady state combustion is maintained for  
15 sustaining a sub-stoichiometric combustion of the fuel and oxygen for producing hot  
16 combustion gases (primarily CO, CO<sub>2</sub>, and H<sub>2</sub>O) which enter and permeate through  
17 the reservoir 10. The hot combustion gases create a gaseous drive front and heat  
18 the reservoir 10 adjacent the combustion cavity 30 and the wellbore.

19 Addition of water to the reservoir 10 along the casing annulus 80  
20 above the combustion chamber 30 injects water into an upper portion of the  
21 reservoir 10 adjacent the wellbore for lateral permeation through the reservoir 10.  
22 The lateral movement of the injected water cools the wellbore from the heat of the  
23 hot combustion gases and minimizes heat loss to the formation adjacent the



1 wellbore. The water further laterally permeates through the reservoir 10 and  
2 converts into steam. The steam and the hot combustion gases in the reservoir 10  
3 form a steam and gaseous drive front.

4 In more detail and referring again to Figs. 1, and 13 – 15B, an injection  
5 well is cased and perforated at a target zone of the reservoir 10.

6 A packer is set and a suitable depth of thermal cement is placed below  
7 the target zone. The thermal cement protects the packer from the downhole burner  
8 60.

9 Referring to Fig. 13, a first main tubing hanger 100 is affixed to a  
10 wellhead 110. A burner bottom hole assembly (burner BHA) 700 comprising a  
11 torque anchor 210, the outer housing 400 of the burner interface assembly 50, a pup  
12 joint 710, and the downhole burner 60 are fluidly connected to a downhole end of a  
13 main tubing string 40. The burner BHA 700 is run downhole to a depth for  
14 positioning the downhole burner 60 within a target zone. In one embodiment, the  
15 downhole burner 60 is positioned at about the midpoint of the target zone. Once in  
16 position, the main tubing string 40 is rotated to set the torque anchor 210 and the  
17 main tubing string 40 is hung from the main tubing hanger 100.

18 As shown in Figs. 1 and 3, the main tubing string 40 and the casing 90  
19 of the wellbore form a casing annulus 80 therebetween. The casing seal 70  
20 between the burner housing 190 and the casing 90 seals the casing annulus 80.

21 Referring to Fig. 14B, an intermediate tubing hanger 130 is supported  
22 on the main tubing hanger 100. With reference to Figs. 14A and 14B, the  
23 intermediate mandrel 410 is fluidly connected to a downhole end of the intermediate

1 tubing string 120, and the concentric tubing 240 defining the oxygen passageway  
2 260 extends downhole from the intermediate mandrel 410. As shown in Fig. 14B,  
3 the intermediate tubing string 120 is run downhole within the bore of the main tubing  
4 string 40. The intermediate mandrel 410 is run downhole until it is tagged with the  
5 outer housing 400 of the burner interface assembly 50. Tagging the intermediate  
6 mandrel 410 to the outer housing 400 involves releaseably connecting the outer  
7 housing 400 to the intermediate mandrel 410 at the intermediate latch assembly  
8 470, forming the intermediate annulus 140 therebetween. The intermediate tubing  
9 string 120 is pulled uphole to stretch the intermediate tubing 120 and remove any  
10 slack. The intermediate tubing string 120 is hung by the intermediate tubing hanger  
11 130 and then cut to an appropriate length.

12           With reference to Fig. 15A, an inner tubing hanger 160 is supported on  
13 the intermediate tubing hanger 130. The inner mandrel 420 of the burner interface  
14 assembly 50 is fluidly connected to a downhole end of the inner tubing string 150,  
15 and run downhole within the intermediate bore of the intermediate tubing string 120.  
16 The inner tubing string 150 is run downhole until the inner mandrel 420 tags the  
17 intermediate mandrel 410 forming the inner annulus 170. Tagging the inner mandrel  
18 420 to the intermediate mandrel 410 involves releaseably connecting the inner  
19 mandrel 420 to the intermediate mandrel 410 at the inner latch assembly 490. The  
20 inner tubing 150 is pulled uphole to stretch the inner tubing 150, hung by the inner  
21 tubing hanger 160 and then cut to an appropriate length. The bore of the inner  
22 tubing string 150 defines the inner bore 180.

1           The intermediate annulus 140 can be fluidly connected to a source of  
2 fuel, and the inner bore 180 can be fluidly connected to a source of oxidant, such as  
3 oxygen. The inner annulus 170 is sealed and is monitored. Any changes with the  
4 pressure within the sealed inner annulus 170 are indicative of a leak in either the  
5 intermediate annulus 140 or the inner bore 180.

6           A further utility of the backpressure valve assembly is to assure  
7 successful latching and continuity of the intermediate and inner tubing string at the  
8 burner interface assembly, an inability of the either passageway to retain pressure  
9 up to the opening pressure of the valves being indicative of a problem in the  
10 connections of one form or another.

11           The fuel can be delivered down the intermediate annulus 140 passing  
12 through the first bypass passageway 610 and first backpressure valve 620 and to  
13 the fuel passageway 250. Similarly, oxygen can be injected down the inner bore  
14 180, through the second bypass passageway 630 and the second backpressure  
15 valve 640 to the oxygen passageway 260. Both the fuel and oxygen enter the  
16 nozzle 200 for combustion. The first and second backpressure valves 620, 640  
17 creates a backpressure greater than that static head to surface pressure, ensuring  
18 that the flow of the fuel and oxygen can be controlled from the surface by controlling  
19 the flow rate of the fuel and oxygen. If the flow rate of the fuel or oxygen does not  
20 create enough pressure to overcome the pressure exerted by the closing force of the  
21 backpressure valve spring 620B, 640B and the reservoir pressure, fuel and oxygen  
22 cannot pass the first and second backpressure valves 620, 640.



1           After the burner assembly 20 is positioned within the target zone, the  
2 reservoir 10 can be initially flooded with water. Water is injected down the casing  
3 annulus 80 to enter the reservoir 10 through the perforations for increasing the  
4 reservoir pressure adjacent the wellbore. The fuel is then injected downhole. After  
5 a sufficient amount of time to ensure that the fuel has entered the target zone  
6 downhole, the fuel is doped with an accelerant, a pyrophoric compound such as  
7 triethylborane or silane, sufficient for igniting the fuel. Oxygen is injected to light off  
8 the downhole burner 60. The accelerant is discontinued to create a stable flame for  
9 combustion. A stable flame can be maintained by controlling the rate of the fuel and  
10 oxygen. The fuel and oxygen are controlled to combust at a temperature to create a  
11 combustion cavity 30 sufficient to melt or otherwise form a cavity 30.

12           In one embodiment, the downhole burner 60 can be lit off and form a  
13 minimum stable flame temperature of about 2800 °C. At such a temperature, it is  
14 believed that the casing 90 and the surrounding reservoir 10 downhole of the burner  
15 60 would melt, forming the combustion cavity 30. As the combustion cavity 30  
16 expands, molten material will flow and pool at a bottom of the combustion cavity 30  
17 above the thermal cement for forming an impermeable glassy bottom. Further, the  
18 heat from the flame continues to be transferred to the lateral walls by a combination  
19 of radiant heat transfer and hot combustion gases permeating into the reservoir 10.  
20 Melting and enlargement of the combustion cavity 30 ceases when the combustion  
21 cavity 30 is sufficiently large enough that the heat transfer from the combustion is  
22 below the melting point of the reservoir 10. The lateral walls of the combustion  
23 cavity 30 remain porous and permeable, perhaps in a sintered state.

1           Once the combustion cavity 30 has been formed, the fuel and oxygen  
2 are controlled to continue steady state combustion for creating and sustaining hot  
3 combustion gases for flowing and permeating into the target zone.

4           Further, the steady state combustion of the fuel and oxygen is also  
5 under sub-stoichiometric conditions, limiting the amount of oxygen available for  
6 combusting with the fuel. The limited amount of available oxygen ensures that there  
7 is no excess oxygen available for flowing into the reservoir 10. Excess oxygen  
8 flowing into the reservoir 10 may result in additional combustion within the reservoir  
9 10 and result in some coking therein.

10           Water is delivered down the casing annulus 80. The casing seal 70  
11 directs the water out the perforations and into the target zone concurrently as hot  
12 combustion gases are created and sustained at steady state. The injected water  
13 and hot combustion gases in the target zone interact to form a drive front comprising  
14 steam and hot combustion gases.

15           The present process further protects the reservoir 10 from permeability  
16 degradation due to chloride scaling by keeping the chlorides in solution. Most  
17 chloride scaling is caused by introducing water with a dissimilar ion charge during  
18 water flooding. Increasing temperature and/or pressure typically improves solubility  
19 of chlorides. The risks of chlorides deposition are reduced as both temperature and  
20 pressure increase with the introduction of heat and CO<sub>2</sub> (from the hot combustion  
21 gases). Higher CO<sub>2</sub> concentrations in formed emulsion increases carbonate  
22 solubility. The process can be operated to continually produce incremental CO<sub>2</sub>,  
23 gradually increasing concentrations as the flood progresses.



1 Risk of chloride scaling is further mitigated by maintaining an 80%  
2 steam quality downhole which keeps chlorides in solution. Untreated produced  
3 water typically contains upwards of 50,000 ppm of total dissolved solids, which is  
4 typically treated prior to being passed through boilers for conventional steam flood  
5 processes. Control of the mass and heat balance of the combustion process  
6 permits management of the steam generation in the target zone to be at about 80%  
7 steam quality. The lower steam quality ensures that there is a sufficient water phase  
8 to keep all dissolved solids in solution and treatment of the produced water is not  
9 required.

10 In an alternate embodiment, fuel can be injected downhole through the  
11 inner bore 180, while the oxygen can be injected down through the intermediate  
12 annulus 140.

13 Further, in an alternate embodiment, where regulation may prohibit  
14 injection of fluid down the casing annulus 80, water can be injected down one o the  
15 other passageways. For example, water could be injected down the intermediate  
16 annulus 140 for injection at the burner assembly for communication with the  
17 hydrocarbon reservoir. In such an embodiment, the inner annulus 170 can be used  
18 to inject fuel or oxygen, instead of being used as a sensing annulus for detecting  
19 leaks, oxygen or fuel could continue to be injected down in the inner bore 180.  
20 Further, as those skilled in the art would understand, the intermediate annulus 140  
21 would have a water injection port in the burner assembly and placed in fluid  
22 communication with the reservoir to allow the injected water to flow into and  
23 permeate through the reservoir and a flow through packer can be used to isolate the



1 burner assembly 20. One approach is to locate a flow-through packer at about the  
2 burner assembly for sealing the casing annulus above the water injection port.  
3 Water injected from the intermediate annulus would exit from the water injection port  
4 and into an injection annulus formed in the casing annulus between the packer and  
5 the casing seal.

6 Further still, yet, in a further alternate embodiment, the inner tubing  
7 string 150 can be eliminated such as to reduce costs. In such an embodiment, the  
8 main tubing string 40 can be disposed within the casing 90 forming the casing  
9 annulus 80, and the intermediate tubing string 120 can be disposed in the main  
10 tubing string 40 forming the intermediate annulus 140. The intermediate tubing  
11 string 120 would have a bore forming the inner bore 180. This embodiment would  
12 not have the inner annulus 170 to serve as a sensing annulus for detecting leaks in  
13 the intermediate annulus 140 and/or the inner bore 180.

14

1                   **THE EMBODIMENTS OF THE INVENTION FOR WHICH AN**  
2 **EXCLUSIVE PROPERTY OR PRIVILEGE IS CLAIMED ARE DEFINED AS**  
3 **FOLLOWS:**

4  
5                   1.       A process for creating a drive front in a hydrocarbon reservoir  
6 for enhanced oil recovery comprising the steps of:

7                   positioning a burner assembly within a target zone in the hydrocarbon  
8 reservoir;

9                   creating a combustion cavity in the target zone with the burner  
10 assembly downhole of the burner assembly;

11                  creating and sustaining hot combustion gases with the burner  
12 assembly for entering into and permeating through the target zone from the  
13 combustion cavity; and

14                  injecting water into the target zone uphole of the burner assembly, for  
15 permeating through the target zone and interacting with the hot combustion gases  
16 therein for creating steam and a steam drive front in the formation.

17  
18                  2.       The process of claim 1, wherein the creating and sustaining of  
19 the hot combustion gases further comprises combusting at sub-stoichiometric  
20 conditions.

21

22

1           3.     The process of claim 1 or 2, wherein the hydrocarbon reservoir  
2 is accessed with a cased wellbore, further comprising forming a casing annulus  
3 between the burner assembly and the cased wellbore, and sealing the casing  
4 annulus uphole of the combustion cavity.

5

6           4.     The process of claim 3, wherein injecting the water into the  
7 target zone further comprises cooling an upper portion of the hydrocarbon reservoir  
8 adjacent the cased wellbore.

9

10          5.     The process of claims 3 or 4, wherein injecting the water into  
11 the target zone further comprises cooling the cased wellbore.

12

13          6.     The process of claim 3, 4 or 5, wherein injecting the water into  
14 the target zone further comprises injecting water through the casing annulus.

15

16          7.     The process of claim 3, 4 or 5, wherein injecting the water into  
17 the target zone further comprises injecting water from the burner assembly.

18

19          8.     The process of any one of claims 1 to 7, wherein creating a  
20 combustion cavity further comprises creating a combustion cavity having a  
21 substantially impermeable base and permeable lateral walls.



1           9.     The process of any one of claims 1 to 8, wherein the  
2 hydrocarbon reservoir is accessed with a cased wellbore and wherein positioning  
3 the burner assembly within a target zone further comprises:

4                 running a main tubing string, a torque anchor and the burner assembly  
5 downhole into the cased wellbore and setting the torque anchor with the burner  
6 assembly within the target zone, a casing annulus being formed therebetween; and

7                 running an intermediate tubing string downhole within a main bore of  
8 the main tubing string and fluidly connecting the intermediate tubing string to the  
9 burner assembly, the intermediate tubing string having an intermediate bore and  
10 forming an intermediate annulus between the main tubing string and the  
11 intermediate tubing string,

12                 wherein discrete passageways are provided for supplying water, fuel  
13 and oxygen to the burner assembly.

14

15           10.    The process of claim 9 further comprising releaseably  
16 connecting the intermediate tubing string to the main tubing string.

17

18

1           11.    The process of claim 9 or 10 further comprising:  
2            running an inner tubing string downhole within the intermediate bore of  
3 the intermediate tubing string and fluidly connecting the inner tubing string to the  
4 burner assembly, the inner tubing string having an inner bore and forming an inner  
5 annulus between the intermediate tubing string and the inner tubing string,  
6            wherein discrete passageways are provided for supplying at least  
7 water, fuel and oxygen to the burner assembly.

8  
9           12.    The process of claim 11 further comprising releaseably  
10 connecting the inner tubing string to the intermediate tubing string.

11  
12           13.    The process of any one of claims 9 to 12 further comprising:  
13            releaseably connecting the intermediate tubing string to the main  
14 tubing string;  
15            stretching the intermediate tubing string;  
16            hanging the intermediate tubing string; and  
17            cutting the intermediate tubing string to an appropriate length.

18  
19

1           14.    The process of any one of claims 11 to 12 further comprising:  
2            releaseably connecting the inner tubing string to the intermediate  
3 tubing string;  
4            stretching the inner tubing string;  
5            hanging the inner tubing string; and  
6            cutting the inner tubing string to an appropriate length.

7  
8           15.    The process of any one of claims 1 to 14, wherein creating a  
9 combustion cavity in the target zone with the burner assembly further comprises  
10 creating the combustion cavity at a temperature sufficient to melt the reservoir.

11  
12           16.    A downhole steam generator for enhanced oil recovery from a  
13 hydrocarbon reservoir accessed by a cased and completed wellbore having a  
14 wellhead, comprising:

15                a main tubing string fluidly connected to the wellhead and supported in  
16 the cased wellbore;

17                at least an intermediate tubing string having an intermediate bore and  
18 disposed within a main bore of the main tubing string for forming an intermediate  
19 annulus therebetween, the main bore and the intermediate annulus forming at least  
20 two fluid passageways;

21                a burner assembly within the cased wellbore positioned at the  
22 hydrocarbon reservoir, the burner assembly having a downhole burner and a burner  
23 interface assembly for fluidly connecting the downhole burner to at least the main



1 tubing string and the intermediate tubing string for fluidly connecting the burner  
2 assembly to the wellhead, the burner interface assembly further comprising

3 an outer housing fluidly connected at an uphole end with the  
4 main tubing string and fluidly connected by the intermediate annulus at a  
5 downhole end with the downhole burner,

6 an intermediate mandrel connected at an uphole end with the  
7 intermediate tubing string and fluidly connecting the intermediate bore at a  
8 downhole end with the downhole burner, the intermediate mandrel fit within  
9 the outer housing, and

10 an intermediate latch assembly between the outer housing and  
11 the intermediate mandrel for releasably connecting therebetween;

12 a high temperature casing seal adapted for sealing a casing annulus  
13 between the downhole burner and the cased wellbore; and  
14 means for injection of water to the hydrocarbon reservoir above the  
15 casing seal.

16

17 17. The generator of claim 16 wherein the casing seal is a brush  
18 seal.

19

20 18. The generator of claim 17, wherein the brush seal further  
21 comprises a stack of a plurality of flexible brush rings.

22

1            19. The generator of claim 18, wherein each of the plurality of  
2 flexible brush rings comprises an annular ring having a multiplicity of  
3 circumferentially spaced, radially inwardly extending slits forming flexible fingers.

4

5            20. The generator of claim 19, wherein each of the flexible brush  
6 rings are rotationally indexed from one another to misalign slits of the adjacent brush  
7 rings.

8

9            21. The generator of claim 16 wherein at least a third passageway  
10 is connected to the downhole burner, further comprising:

11            an inner tubing string disposed within the intermediate bore of the  
12 intermediate tubing string for forming an inner annulus therebetween, the inner  
13 tubing string having an inner bore, the intermediate tubing string and inner tubing  
14 string fluidly connecting the burner assembly to the wellhead; and

15            wherein the burner interface assembly further comprises:

16            an inner mandrel connected an uphole end to the inner tubing string  
17 and fluidly connecting the inner bore at a downhole end with the downhole burner,  
18 the inner mandrel fit within the intermediate mandrel; and

19            an inner latch assembly between the intermediate mandrel and the  
20 inner mandrel for releaseably connecting therebetween.

21

1           22.    The generator of claim 21 wherein the intermediate tubing string  
2 is an intermediate coil tubing string and the inner tubing string is an inner coil tubing  
3 string.

4  
5           23.    The generator of claim 21 or 22, wherein the inner annulus is  
6 sealed at the burner interface assembly for the detection leaks from the intermediate  
7 annulus, the inner bore, or a combination thereof.

8  
9           24.    The generator of claim 21, 22 or 23 wherein the burner interface  
10 assembly further comprises a backpressure valve assembly for at least one of, or  
11 both of, the at least two passageways for fuel and oxygen.

12  
13           25.    The generator of claim 24, wherein the backpressure valve  
14 assembly further comprises a first bypass passageway having a first backpressure  
15 valve for fuel and a second bypass passageway having a second backpressure  
16 valve for oxygen.

17  
18           26.    The generator of any one of claims 21 to 25, wherein the  
19 intermediate annulus fluidly communicates fuel to the downhole burner and wherein  
20 the inner bore fluidly communicates oxygen to the downhole burner.

21

22



1                   27.    A process for creating a drive front in a hydrocarbon reservoir  
2    accessed with a cased wellbore for enhanced oil recovery comprising the steps of:  
3                    positioning a burner assembly within a target zone in the hydrocarbon  
4    reservoir, wherein  
5                    running a main tubing string, a torque anchor and the burner assembly  
6    downhole into the case wellbore and setting the torque anchor with the burner  
7    assembly within the target zone, a casing annulus being formed therebetween; and  
8                    running an intermediate tubing string downhole within a main bore of  
9    the main tubing string and fluidly connecting the intermediate tubing string to the  
10   burner assembly, the intermediate tubing sting having an intermediate bore and  
11   forming an intermediate annulus between the main tubing string and the  
12   intermediate tubing string,  
13                    creating a combustion cavity in the target zone downhole of the burner  
14   assembly;  
15                    creating and sustaining hot combustion gases with the burner  
16   assembly for flowing from the combustion cavity and into the target zone; and  
17                    injecting water into the target zone for interacting with the hot  
18   combustion gases and conversion into steam for creating the drive front.

19  
20

1           28.    The process of claim 27 further comprising:  
2            running an inner tubing string downhole within the intermediate bore of  
3 the intermediate tubing string and fluidly connecting the inner tubing string to the  
4 burner assembly, the inner tubing string having an inner bore and forming an inner  
5 annulus between the intermediate tubing string and the inner tubing string,  
6            wherein discrete passageways are provided for supplying at least  
7 water, fuel and oxygen to the burner assembly.

8  
9           29.    The process of claim 27 or 28 further comprising:  
10          releaseably connecting the intermediate tubing string to the main  
11 tubing string;  
12          stretching the intermediate tubing string;  
13          hanging the intermediate tubing string; and  
14          cutting the intermediate tubing string to an appropriate length.

15  
16          30.    A downhole steam generator for enhanced oil recovery from a  
17 hydrocarbon reservoir accessed by a cased and completed wellbore comprising:  
18          a burner assembly within the cased wellbore positioned at the  
19 hydrocarbon reservoir, the burner assembly having a downhole burner;  
20          a high temperature brush seal having a stack of a plurality of flexible  
21 brush rings, the brush seal being adapted for sealing a casing annulus between the  
22 downhole burner and the cased wellbore, each flexible brush ring comprising an  
23 annular ring having a multiplicity of circumferentially space, radially inwardly

1 extending slits which are rotationally indexed from one another to misalign slits of  
2 the adjacent annular ring; and

3 means for injection of water into the hydrocarbon reservoir above the  
4 brush seal.

5 31. The generator of claim 30, wherein the radially inwardly  
6 extending slits are clockwise oriented spiral slits.

7

8 32. The generator of claim 30 or 31 further comprising spacer rings  
9 between each of the brush rings.

10

11 33. A process for creating a drive front in a hydrocarbon reservoir  
12 for enhanced oil recovery comprising:

13 arranging a burner assembly in a wellbore to access a cavity in a  
14 target zone in the hydrocarbon reservoir;

15 directing combustion from the burner assembly into the cavity and  
16 sustaining hot combustion gases therein, the hot combustion gases entering into  
17 and permeating from the cavity to heat the target zone;

18 injecting water into the target zone, the water entering into and  
19 permeating into the target zone and interacting with the hot combustion gases  
20 therein for creating steam in the target zone; and

21 forming a steam drive front in the hydrocarbon reservoir.

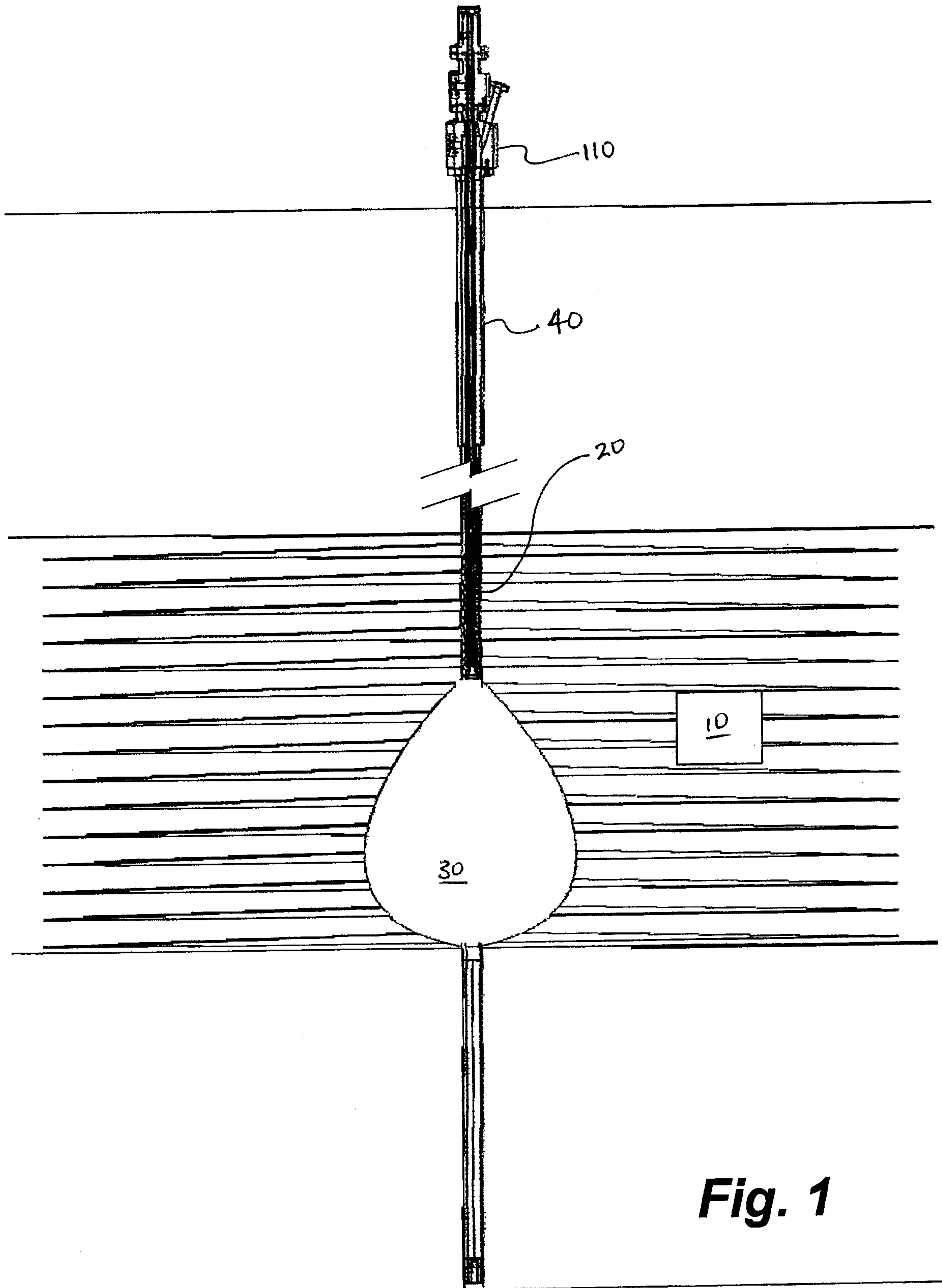
22



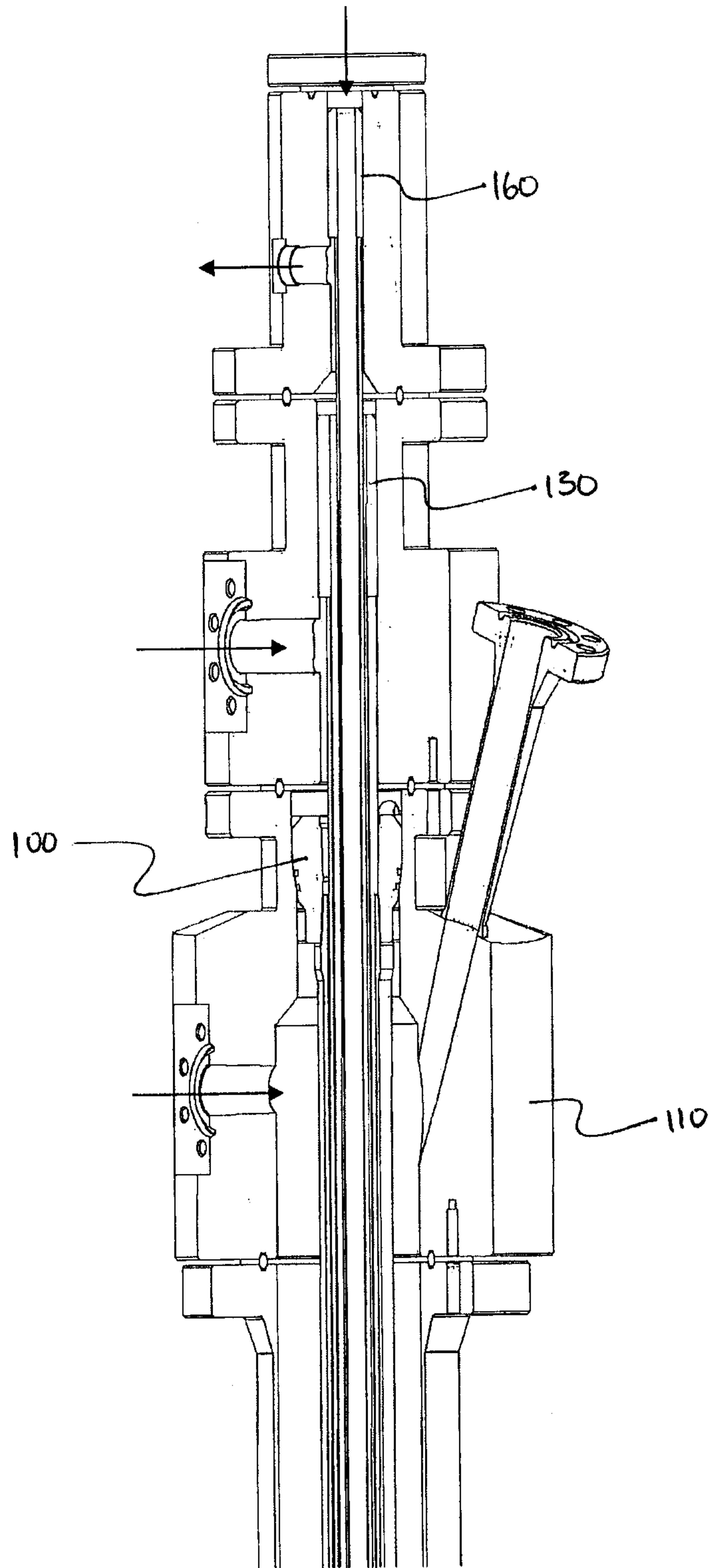
1                   34.    The process of claim 33 wherein injecting water into the target  
2 zone further comprises injecting water from a wellbore annulus between the burner  
3 assembly and the wellbore.

4

5                   35.    The process of claim 33 or 34 further comprising:  
6 sealing the wellbore annulus with an annular seal at about the burner assembly; and  
7 wherein the injecting water from the annulus further comprises  
8                   injecting water into the target zone uphole of the annular seal.

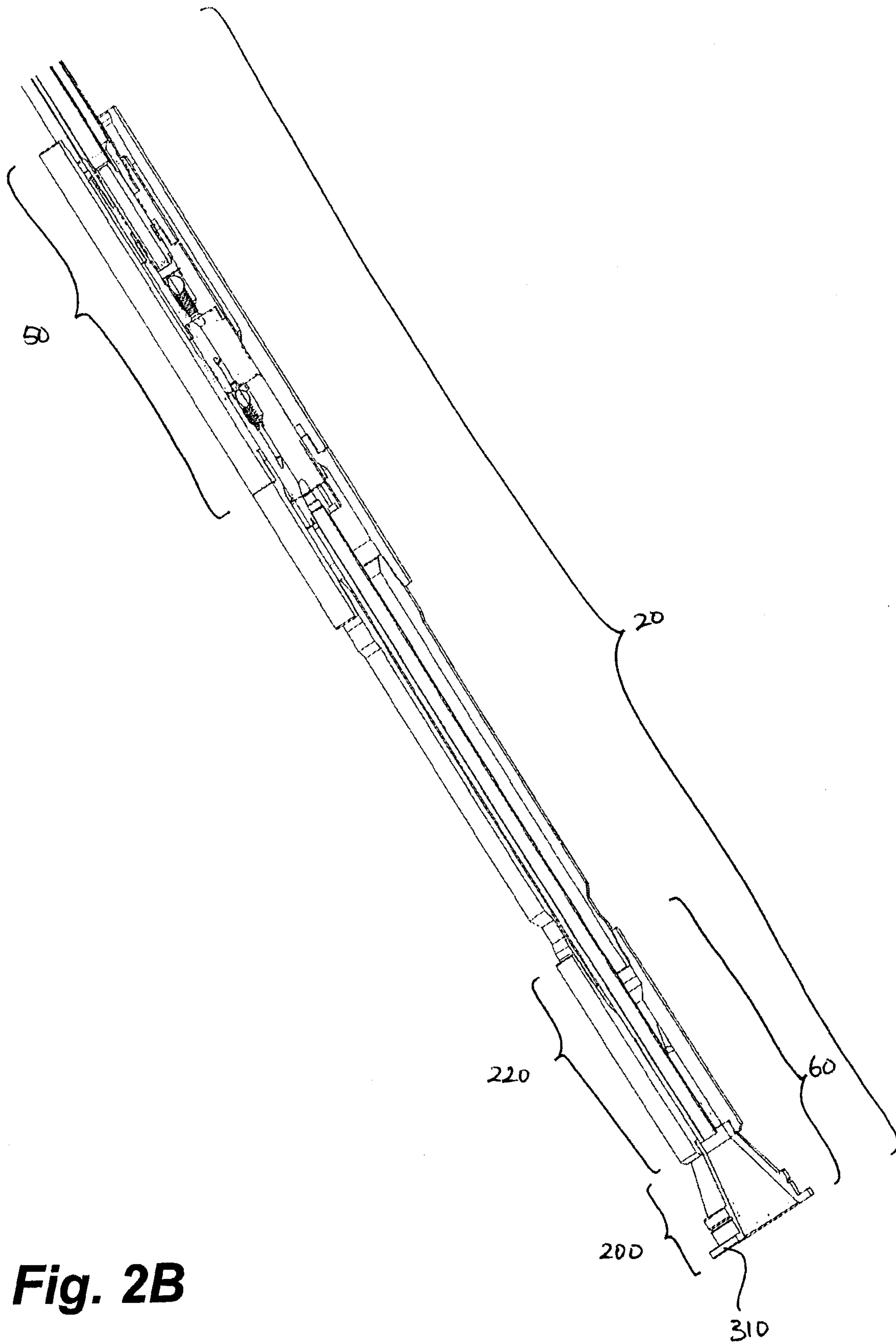


**Fig. 1**

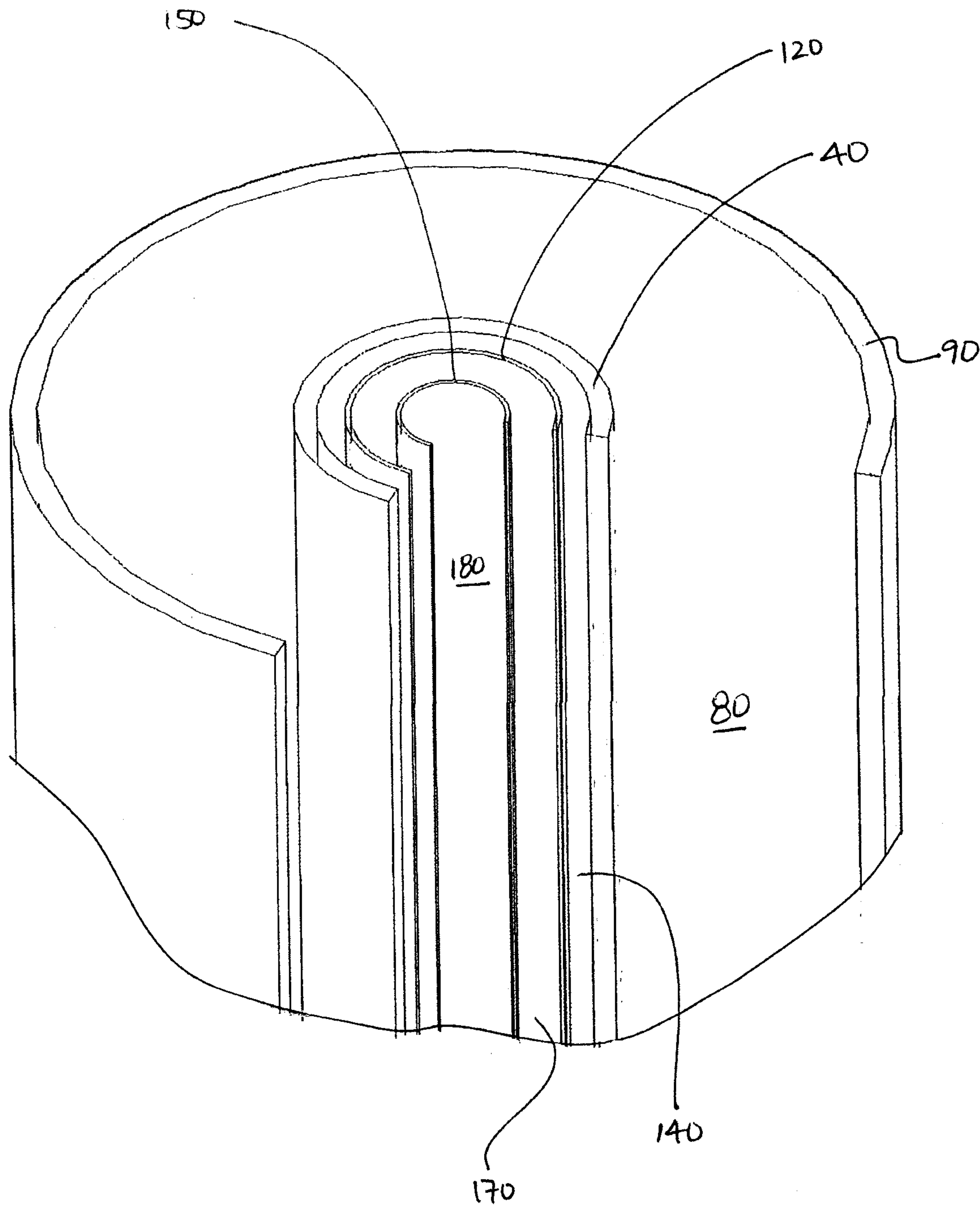


**Fig. 2A**





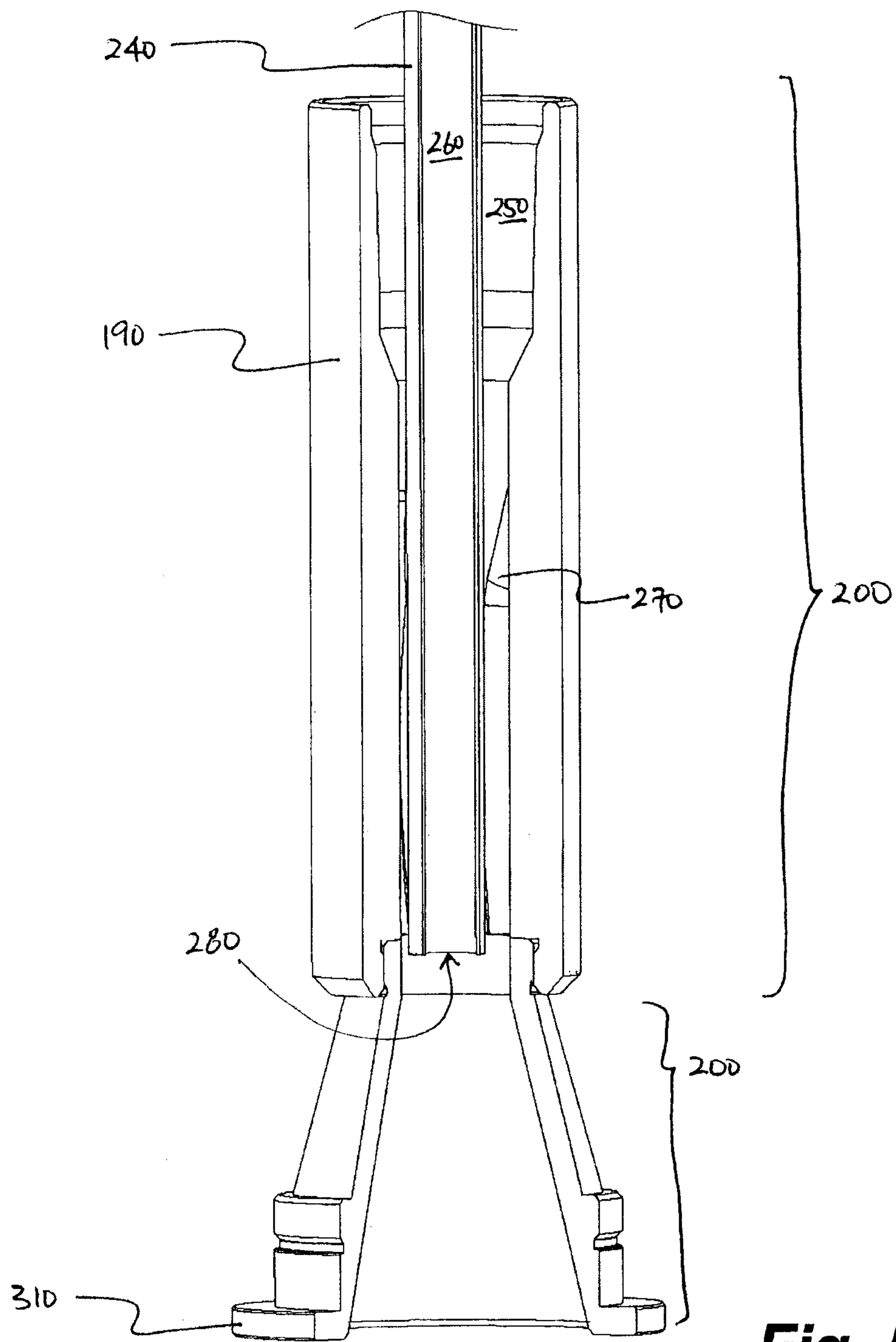
**Fig. 2B**



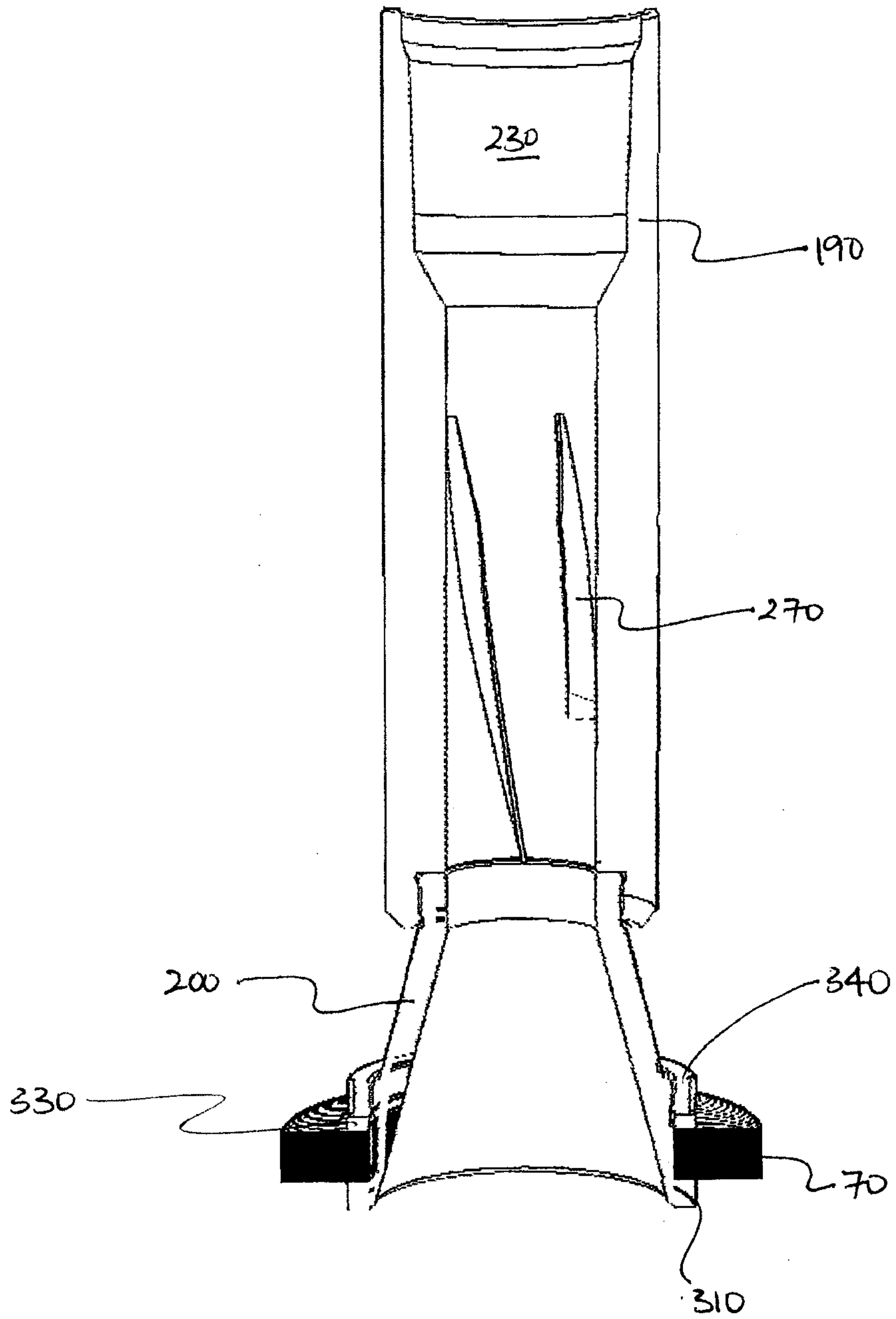
**Fig. 3**





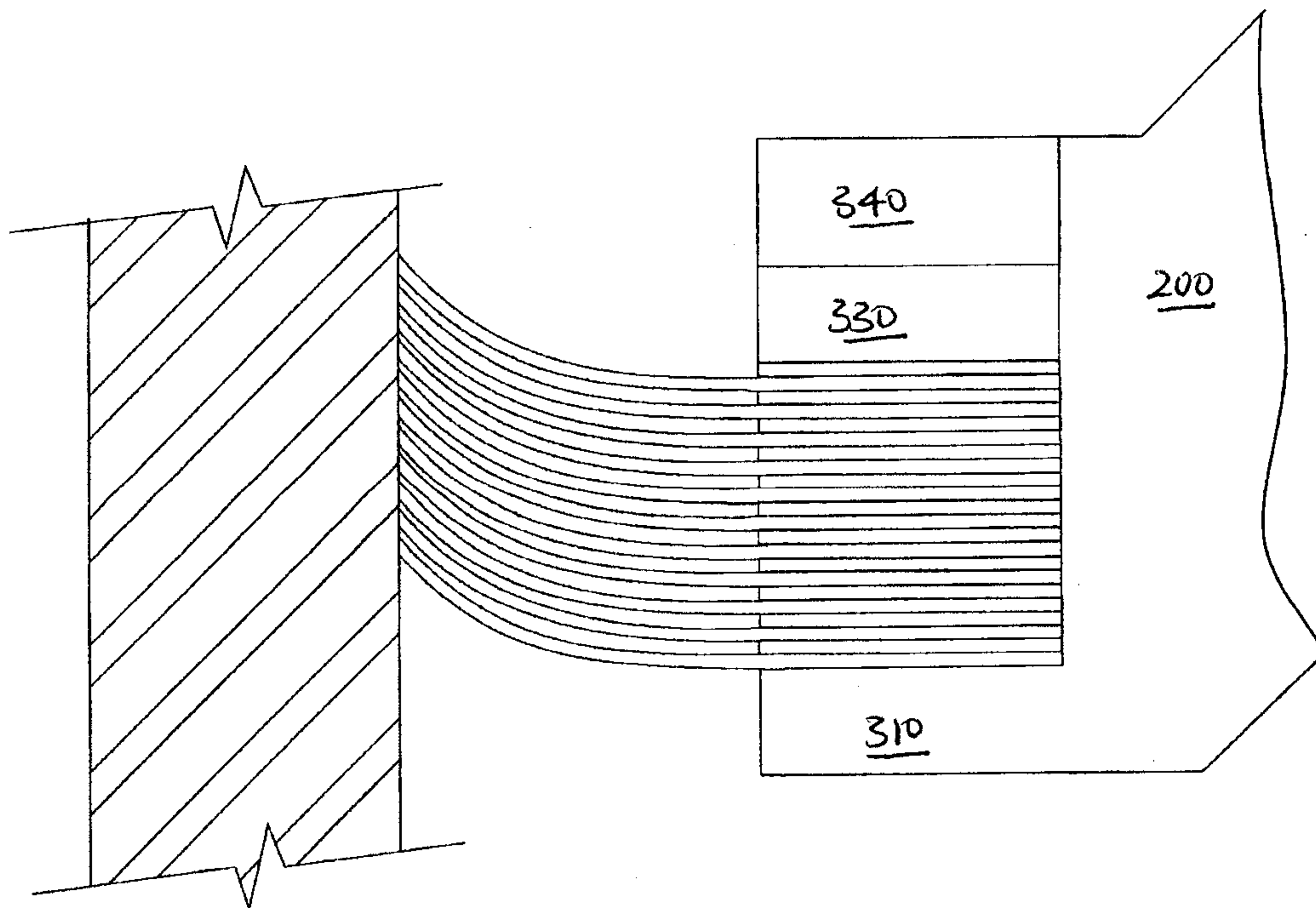
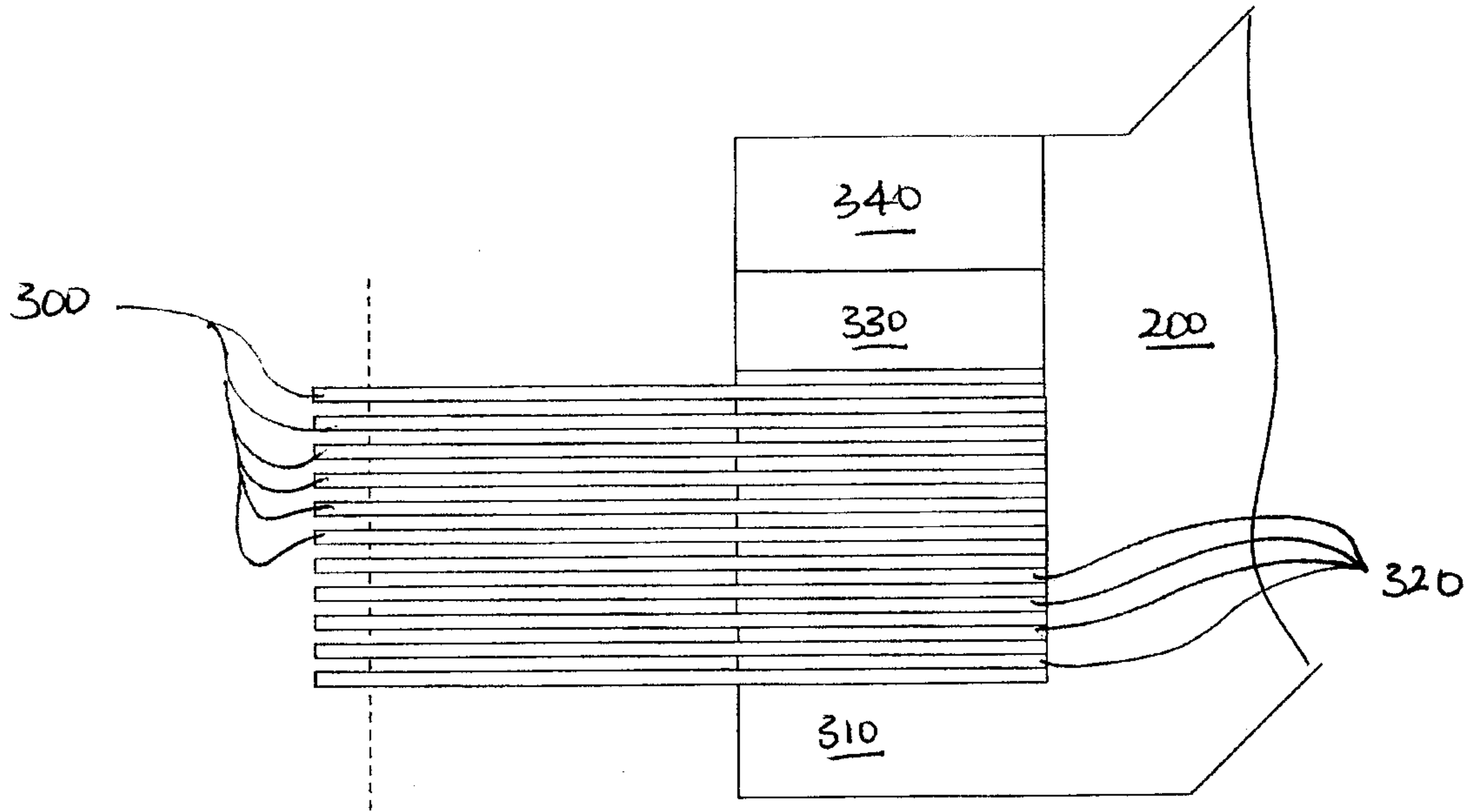


**Fig. 5**



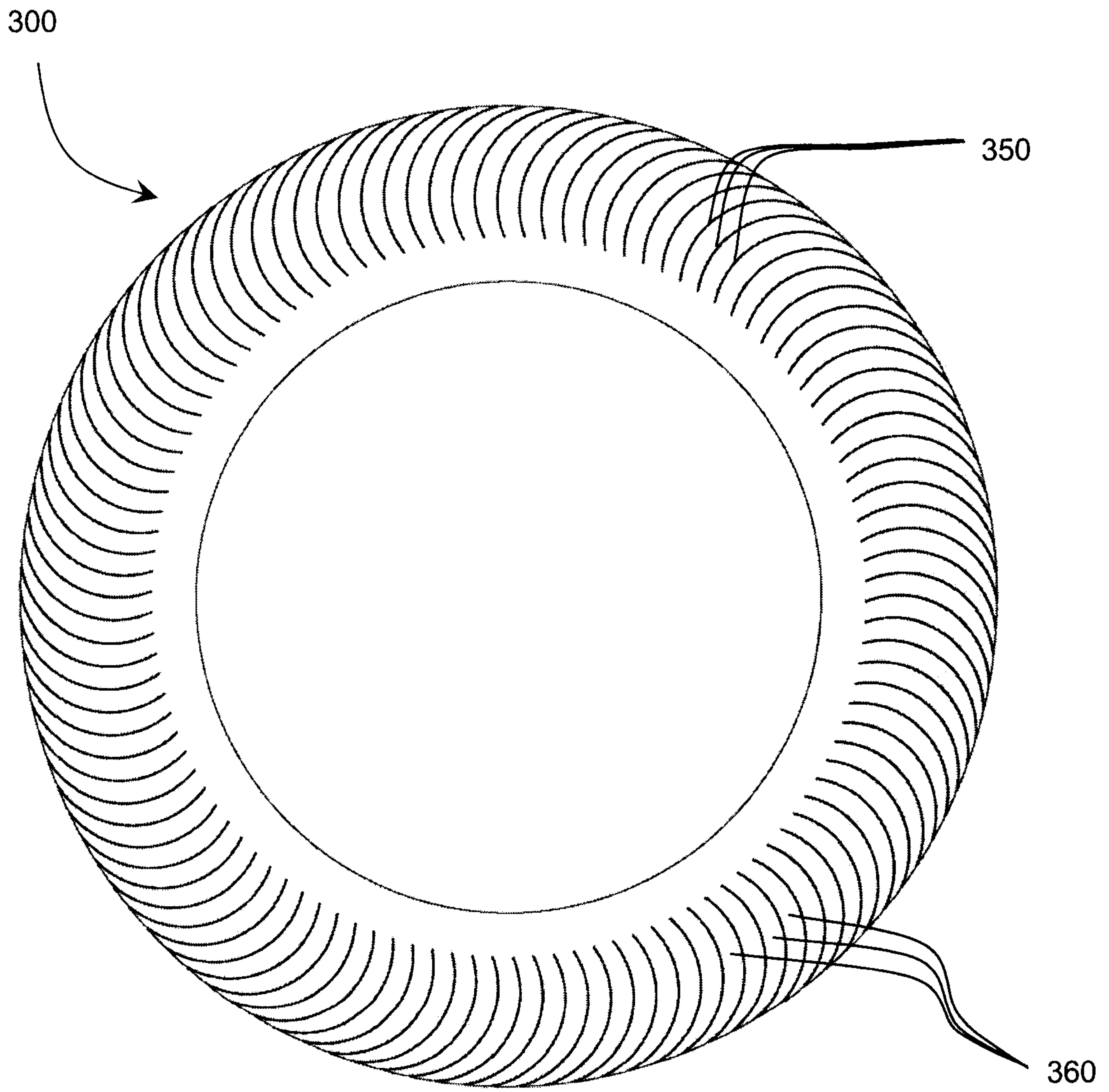
**Fig. 6**

**Fig. 7A**

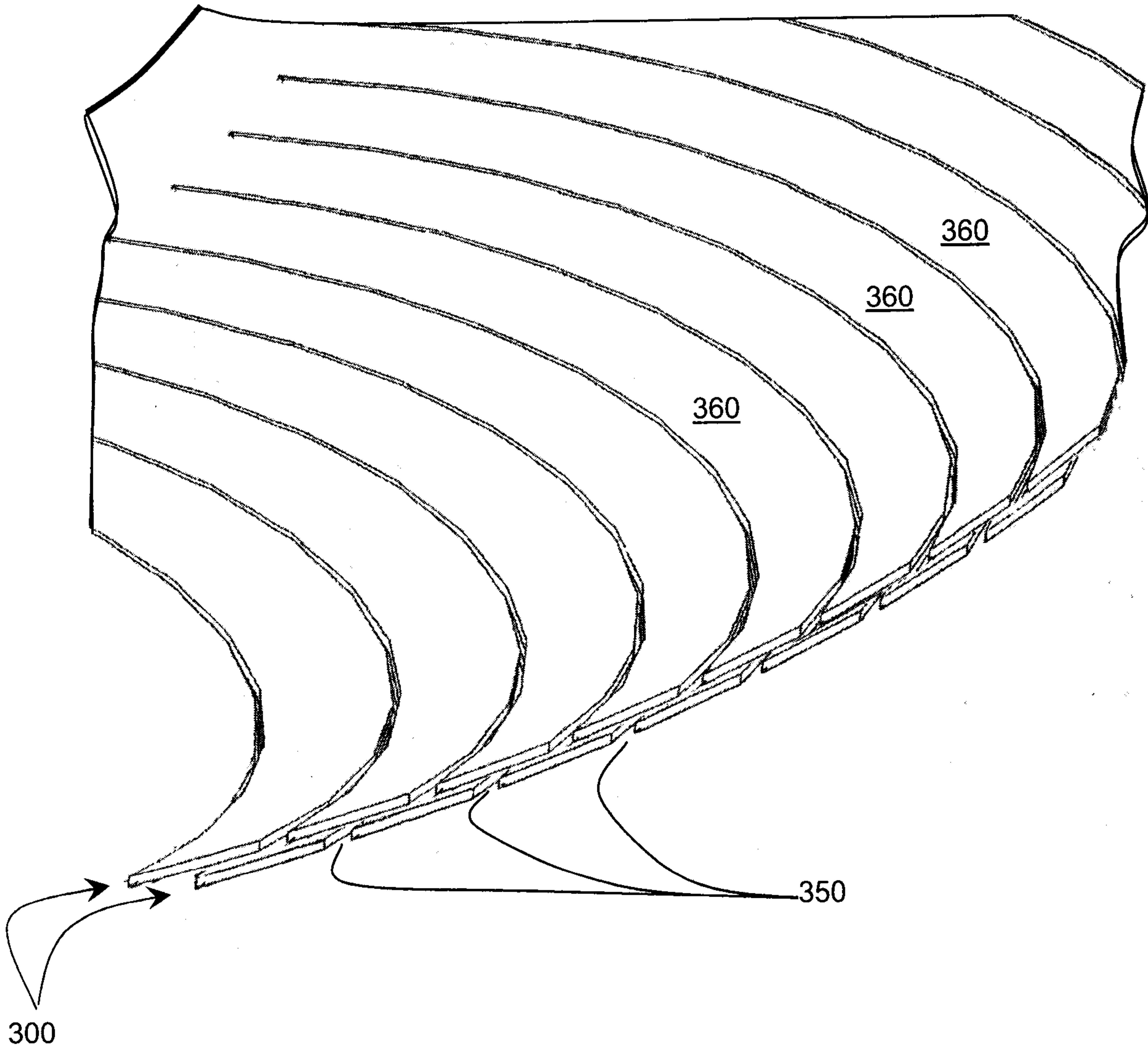


**Fig. 7B**

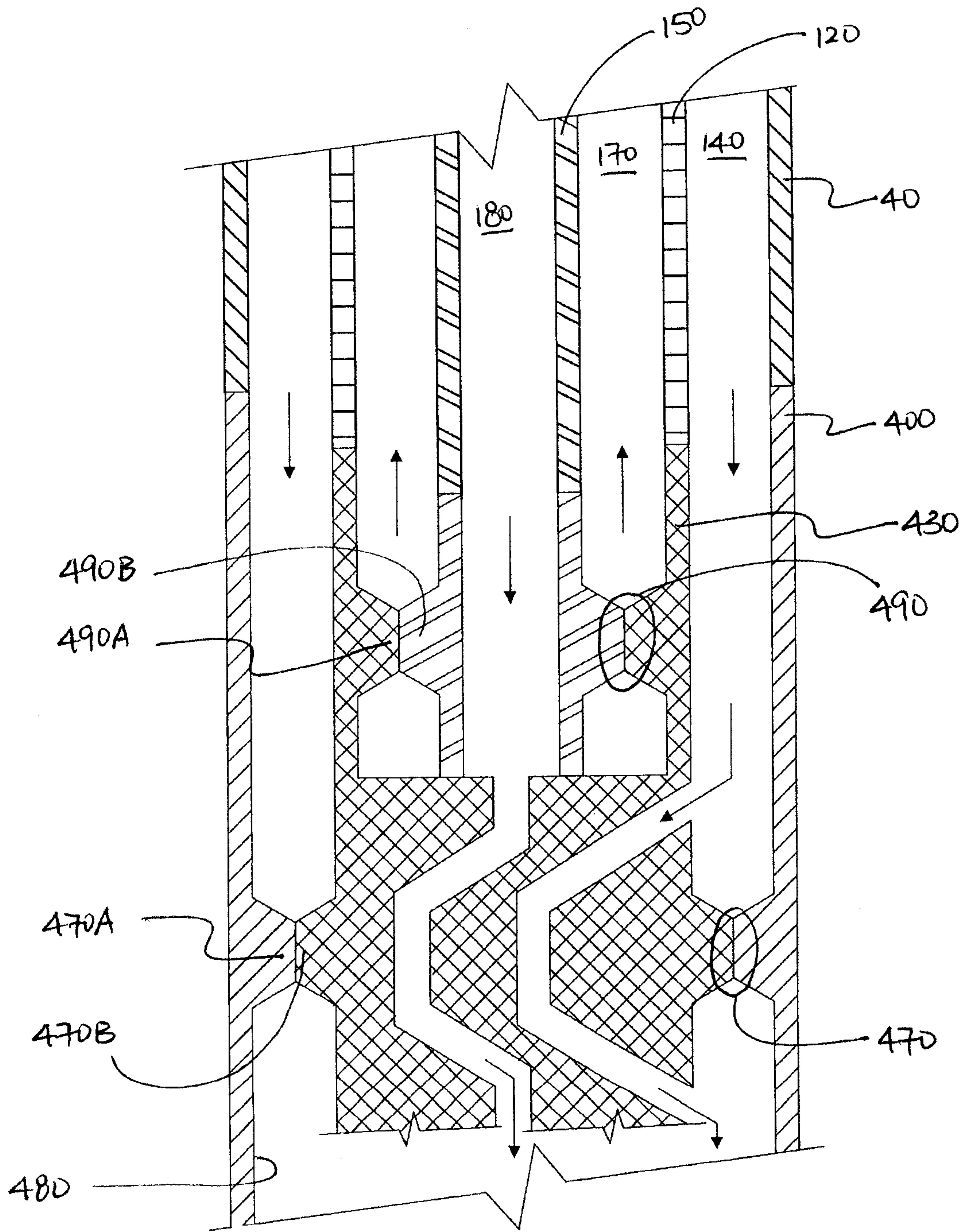




**Fig. 8**

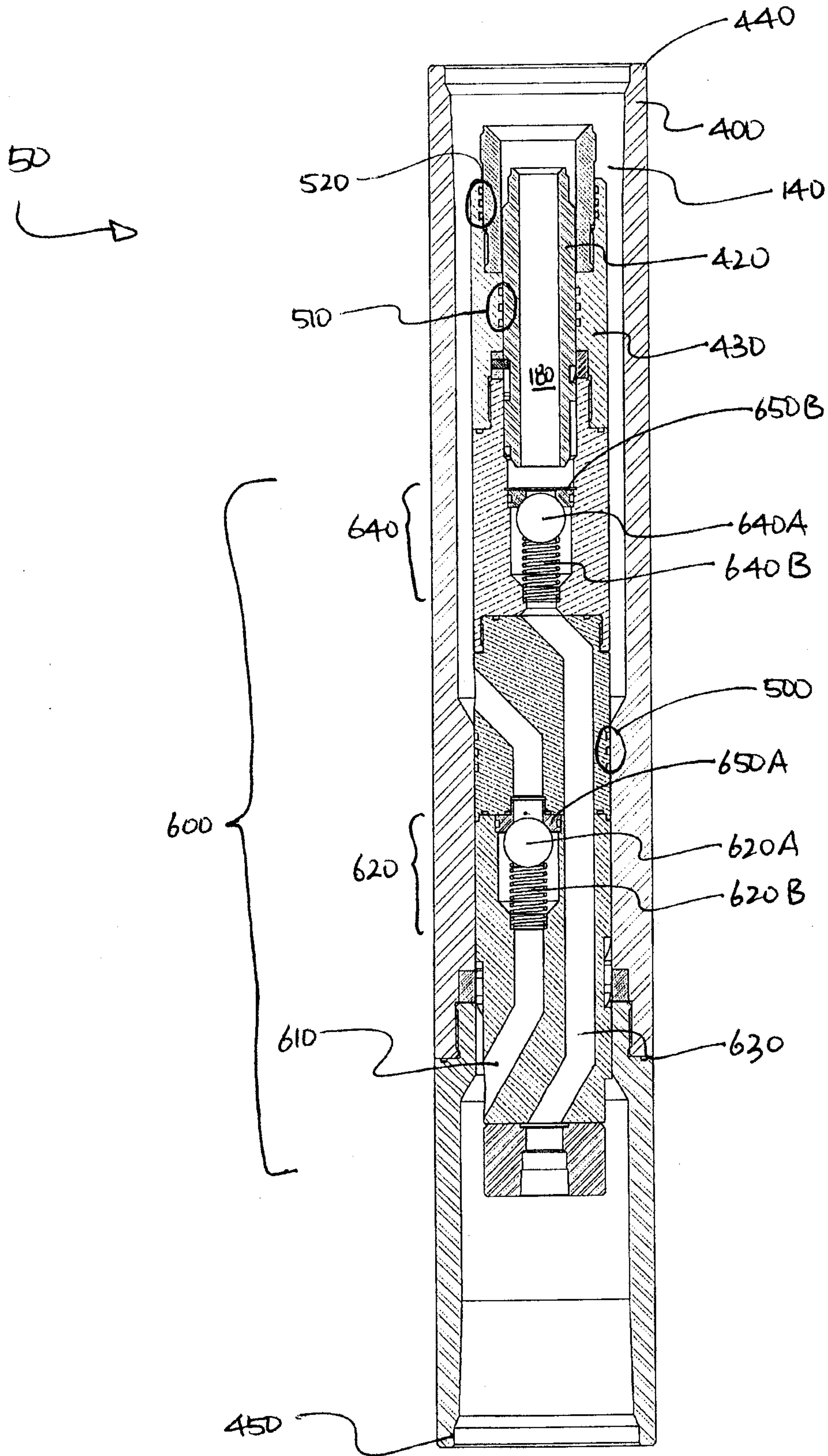


**Fig. 9**

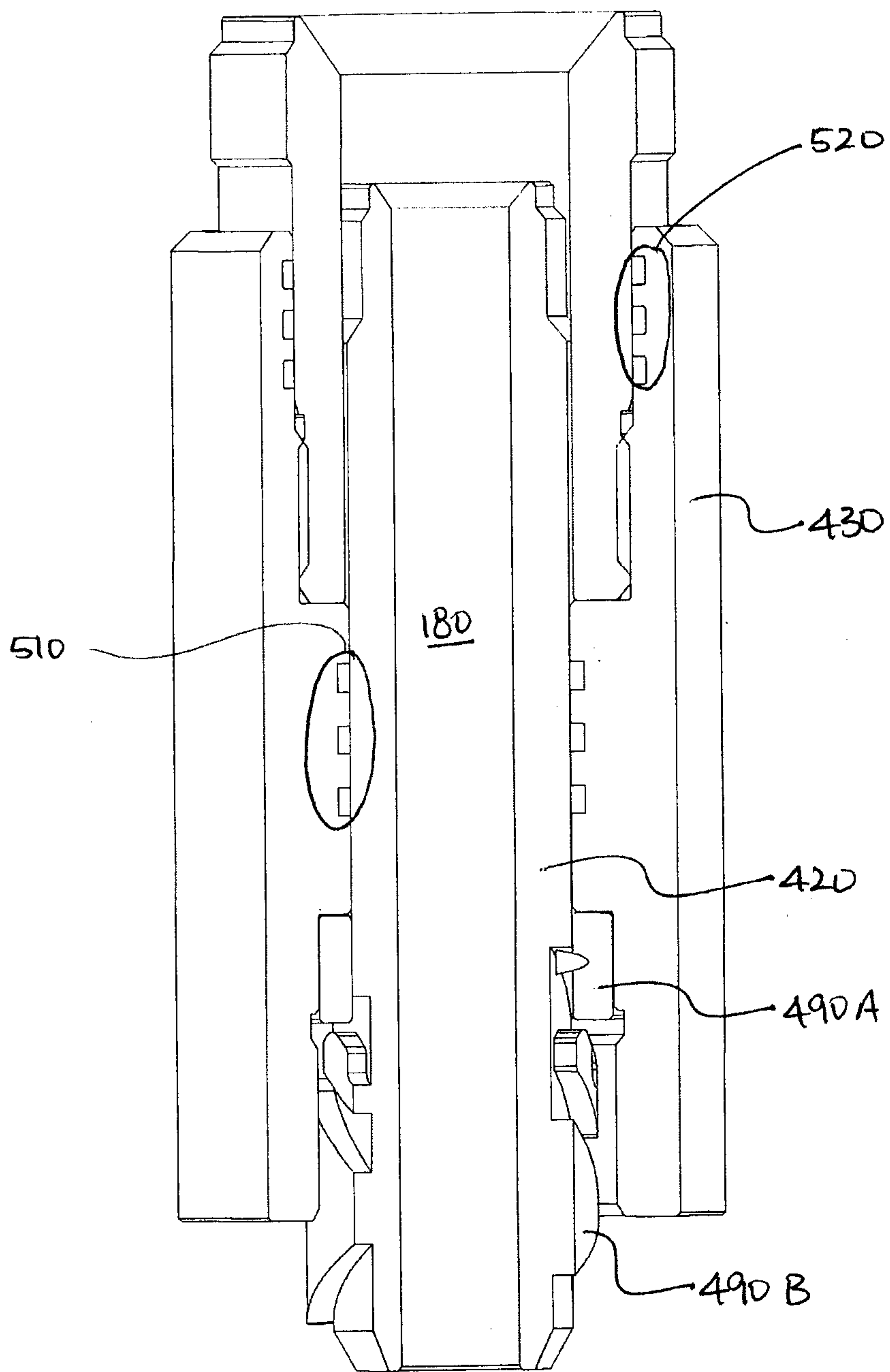


**Fig. 10**

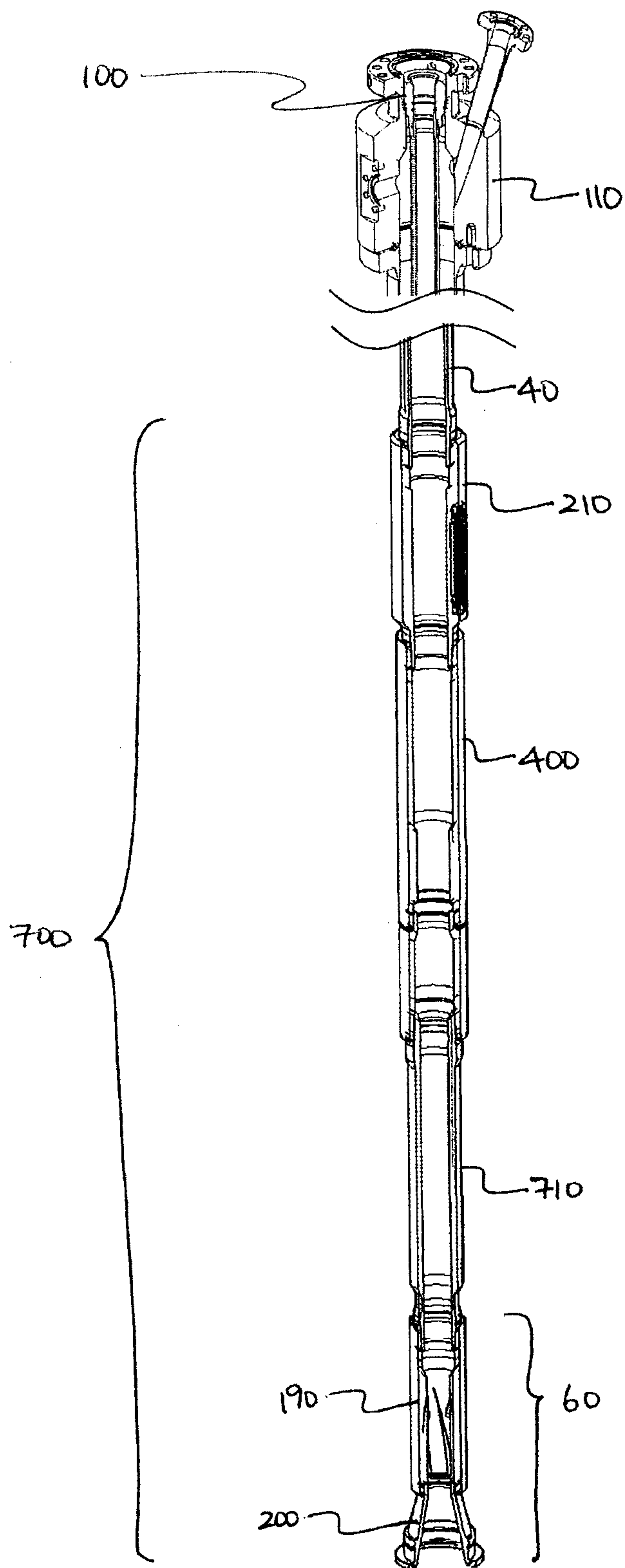




**Fig. 11**



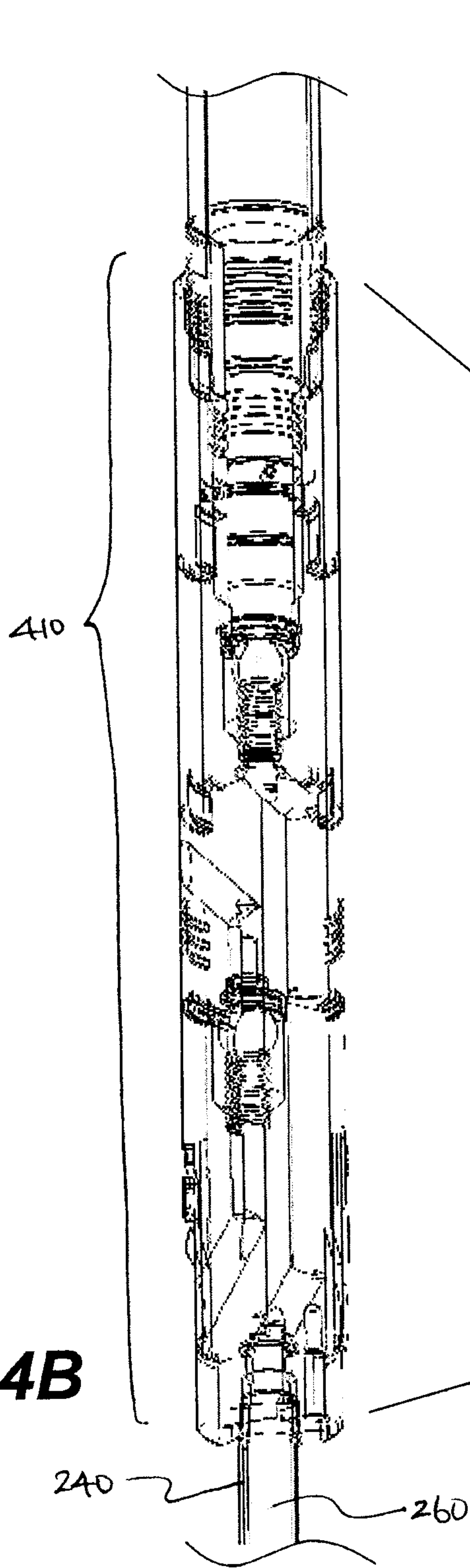
**Fig. 12**



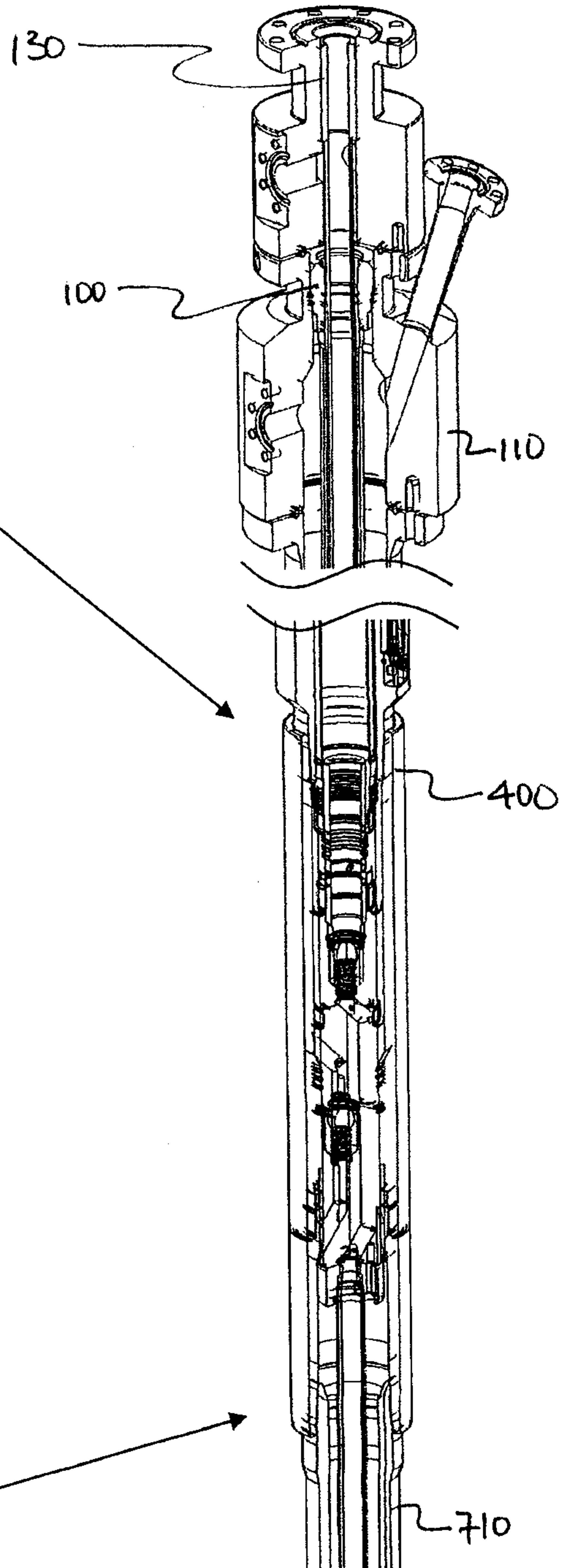
**Fig. 13**

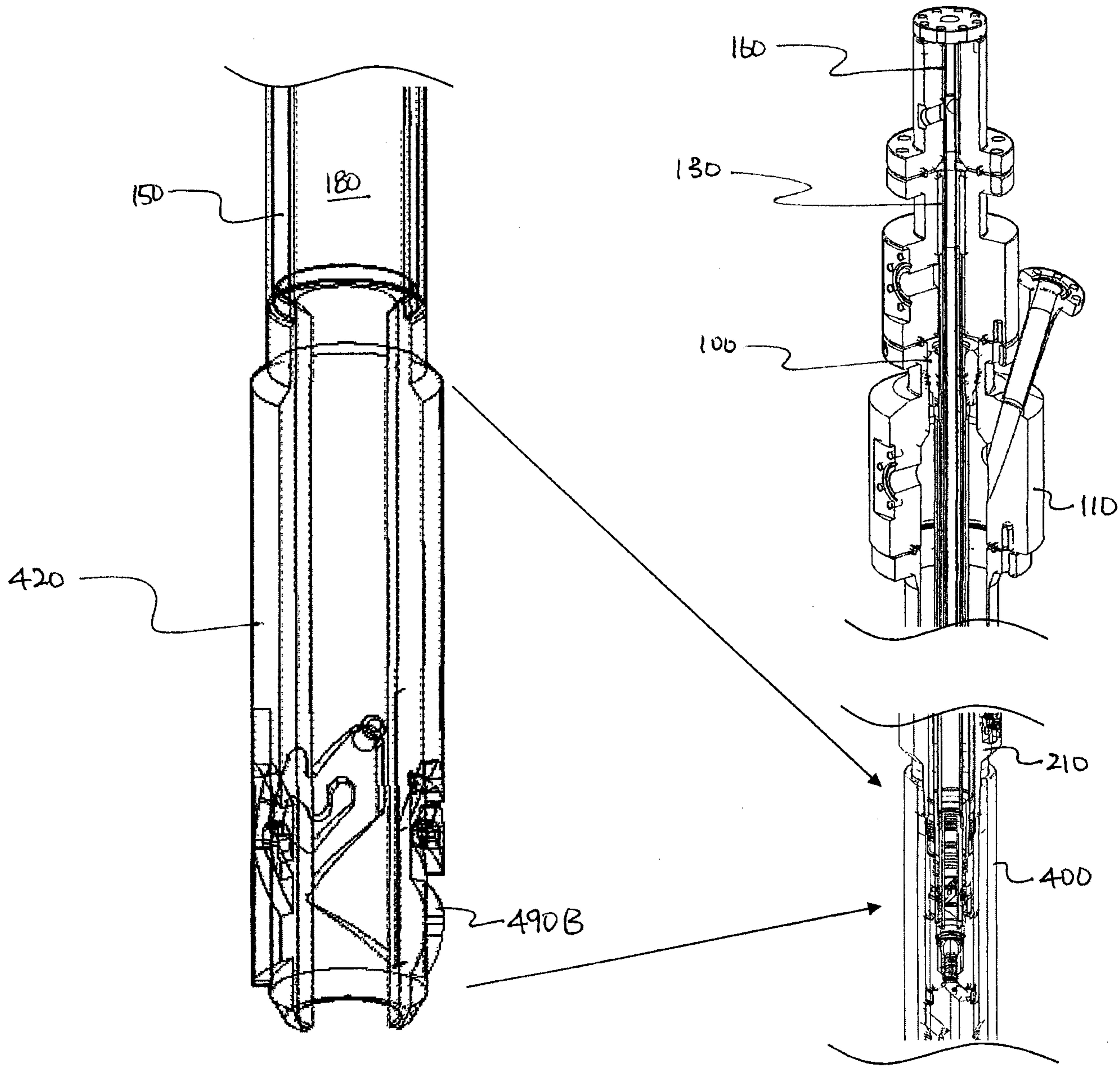


**Fig. 14B**



**Fig. 14A**





**Fig. 15B**

**Fig. 15A**

