



US 20050004648A1

(19) **United States**

(12) **Patent Application Publication**

**Boekstegers**

(10) **Pub. No.: US 2005/0004648 A1**

(43) **Pub. Date: Jan. 6, 2005**

(54) **METHODS AND DEVICES FOR DELIVERING A VENTRICULAR STENT**

(60) Provisional application No. 60/201,732, filed on May 4, 2000.

(75) Inventor: **Peter Boekstegers**, Diessen (DE)

**Publication Classification**

Correspondence Address:  
**FINNEGAN, HENDERSON, FARABOW,  
GARRETT & DUNNER  
LLP  
1300 I STREET, NW  
WASHINGTON, DC 20005 (US)**

(51) **Int. Cl.<sup>7</sup> ..... A61F 2/06**

(52) **U.S. Cl. .... 623/1.11**

(57) **ABSTRACT**

(73) Assignee: **Percardia, Inc.**

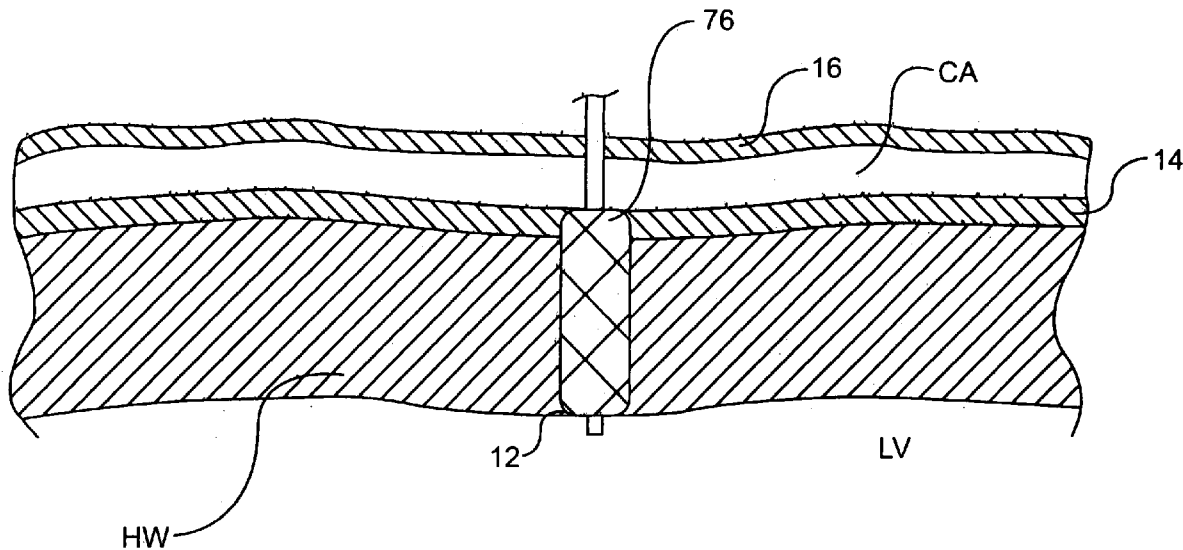
Embodiments of the invention include a device for placing a stent in a heart wall. The device may include a delivery tool configured to deliver the stent to a location within the heart wall, and a stop mechanism disposed on the delivery tool such that the stop mechanism is proximate at least one end of the stent during delivery of the stent. The stop mechanism may be configured to engage a surface to determine the placement location of the stent within the heart wall.

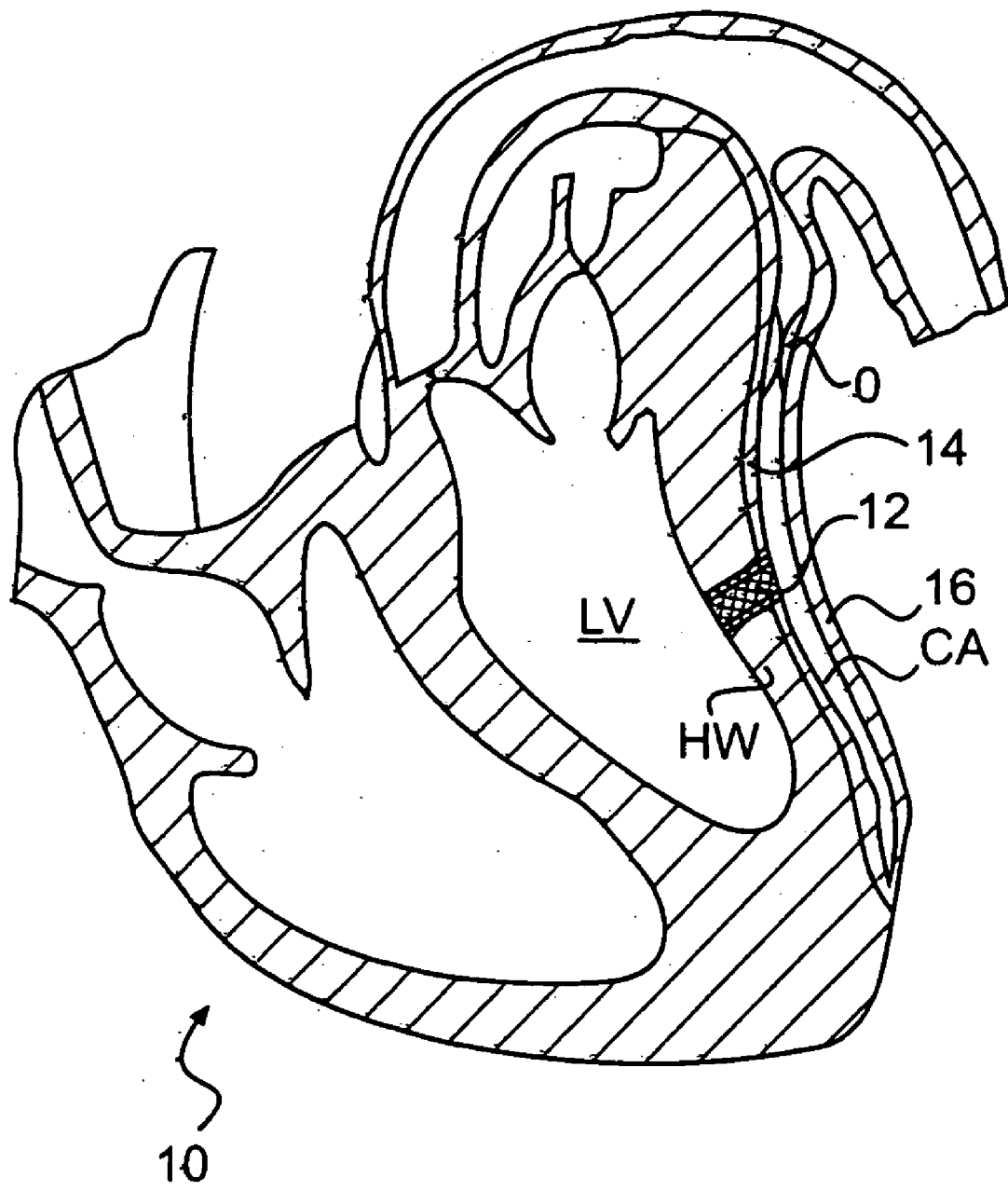
(21) Appl. No.: **10/895,820**

(22) Filed: **Jul. 22, 2004**

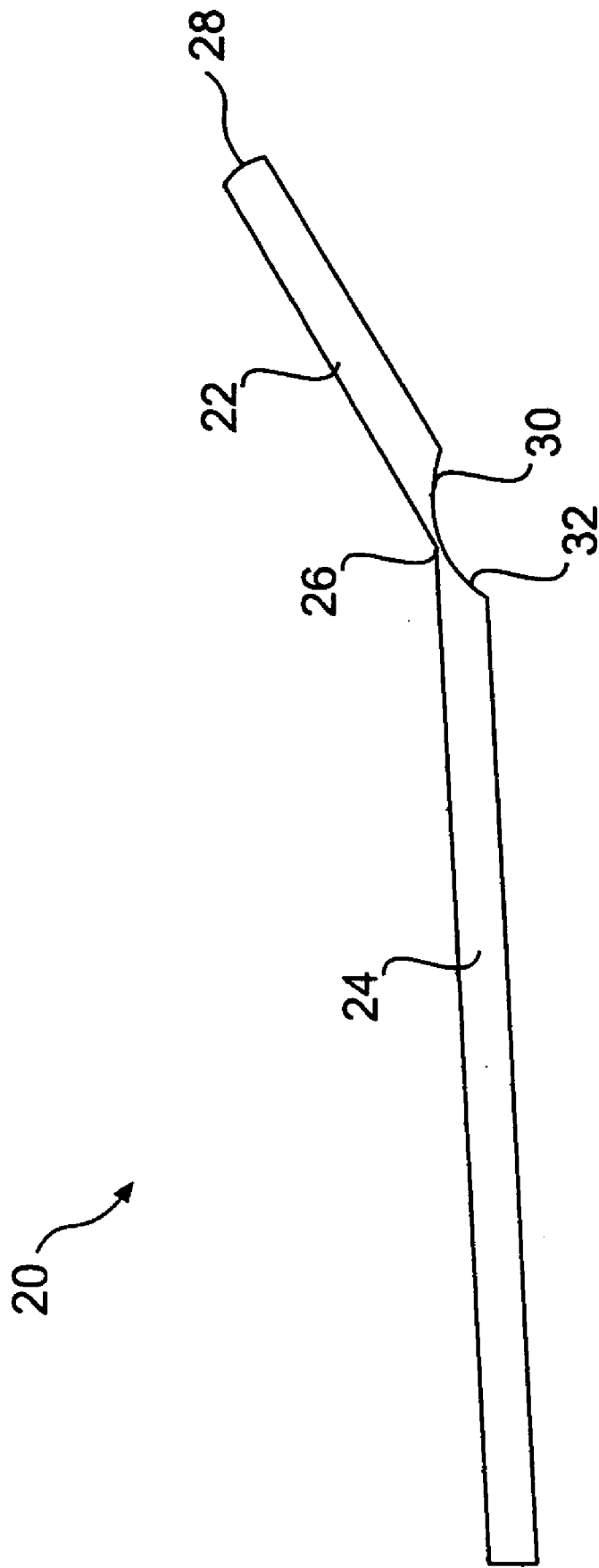
**Related U.S. Application Data**

(63) Continuation of application No. 09/845,154, filed on May 1, 2001.

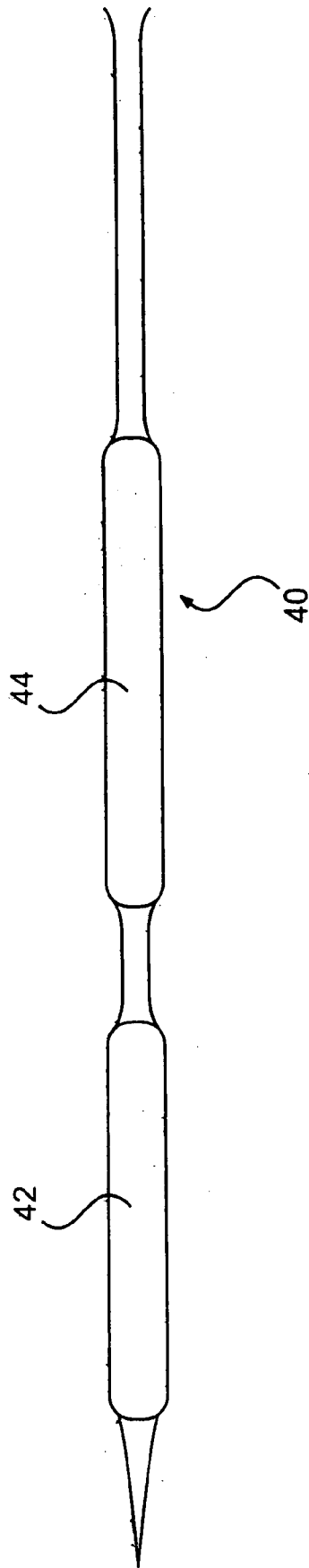




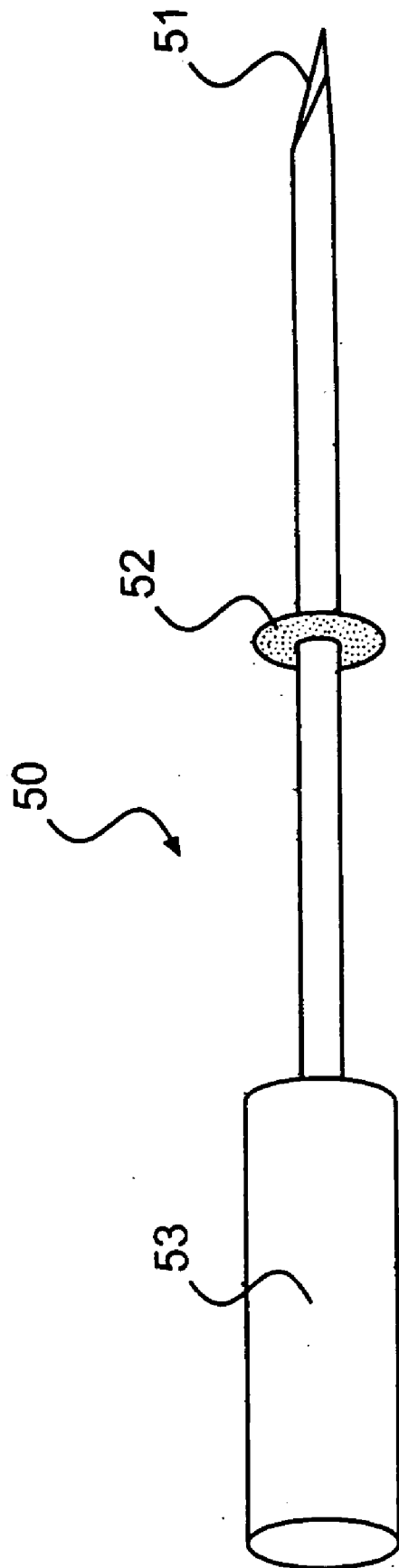
**FIG. 1**



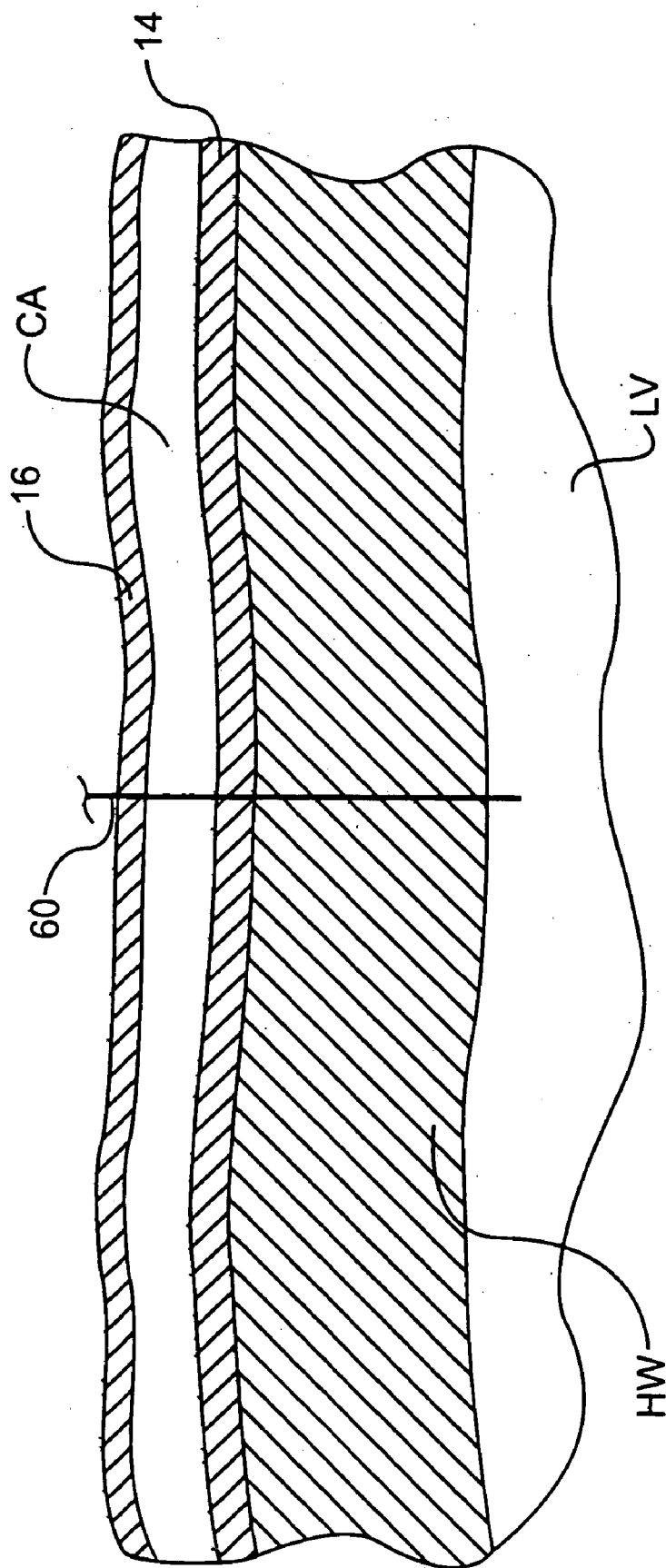
**FIG. 2**



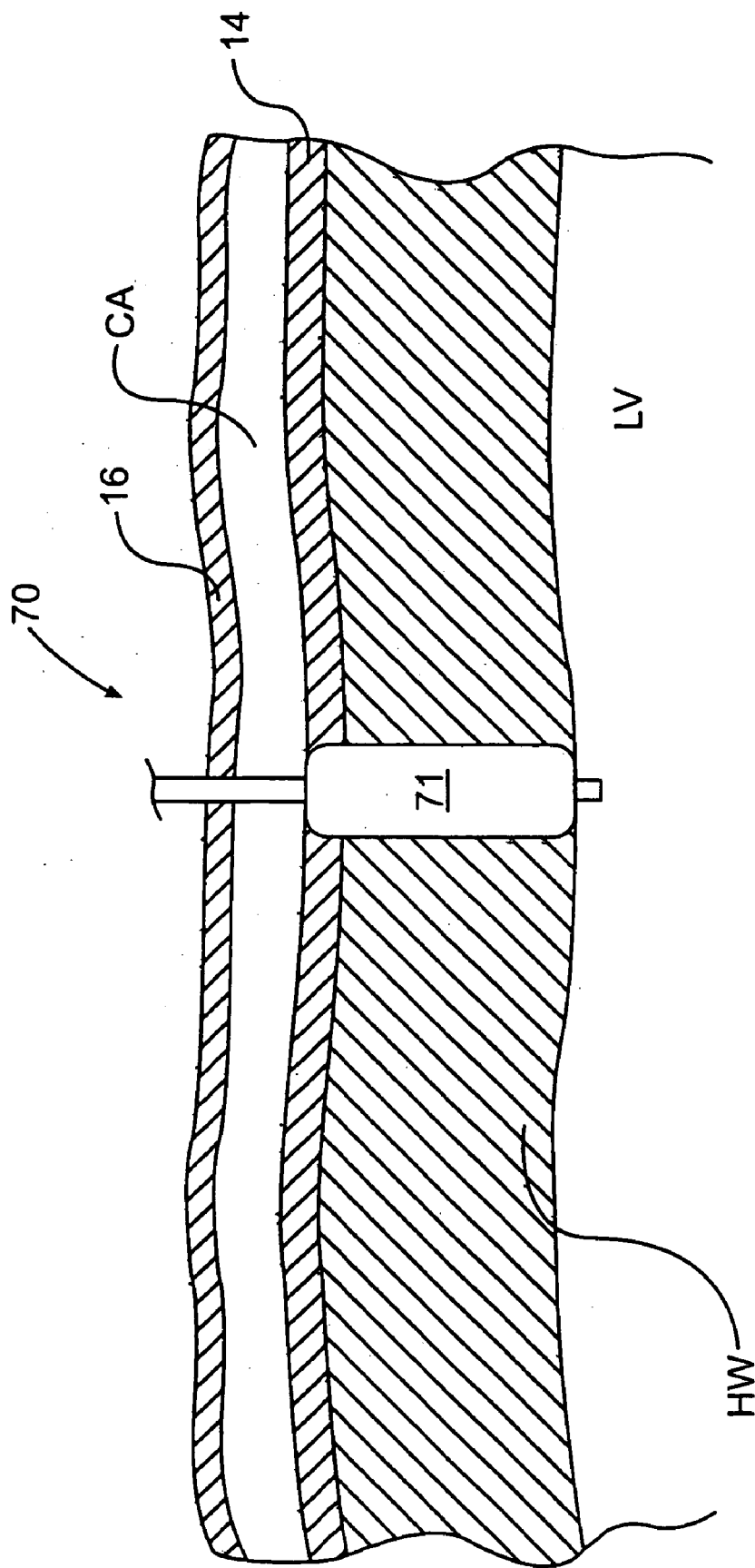
**FIG. 3**



**FIG. 4**



**FIG. 5**



**FIG. 6**

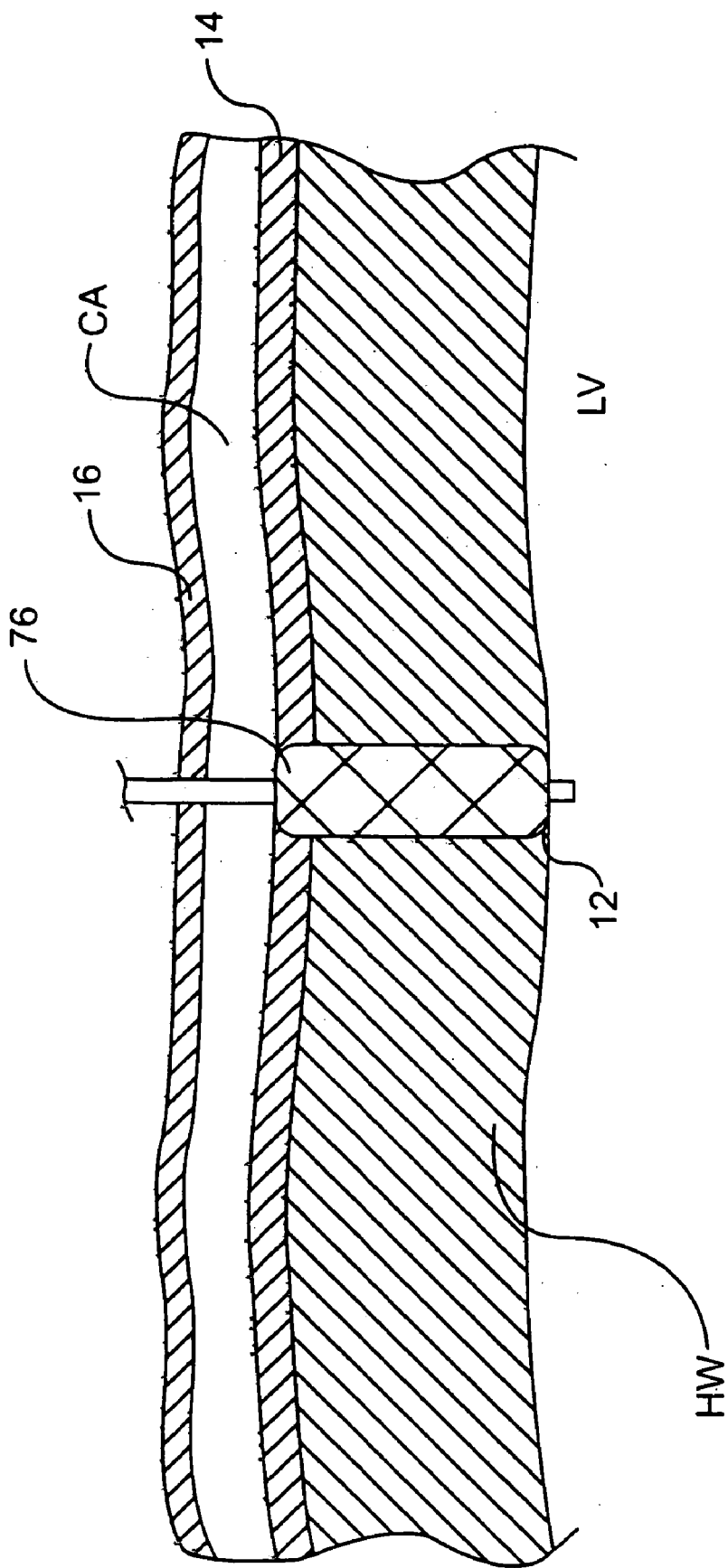
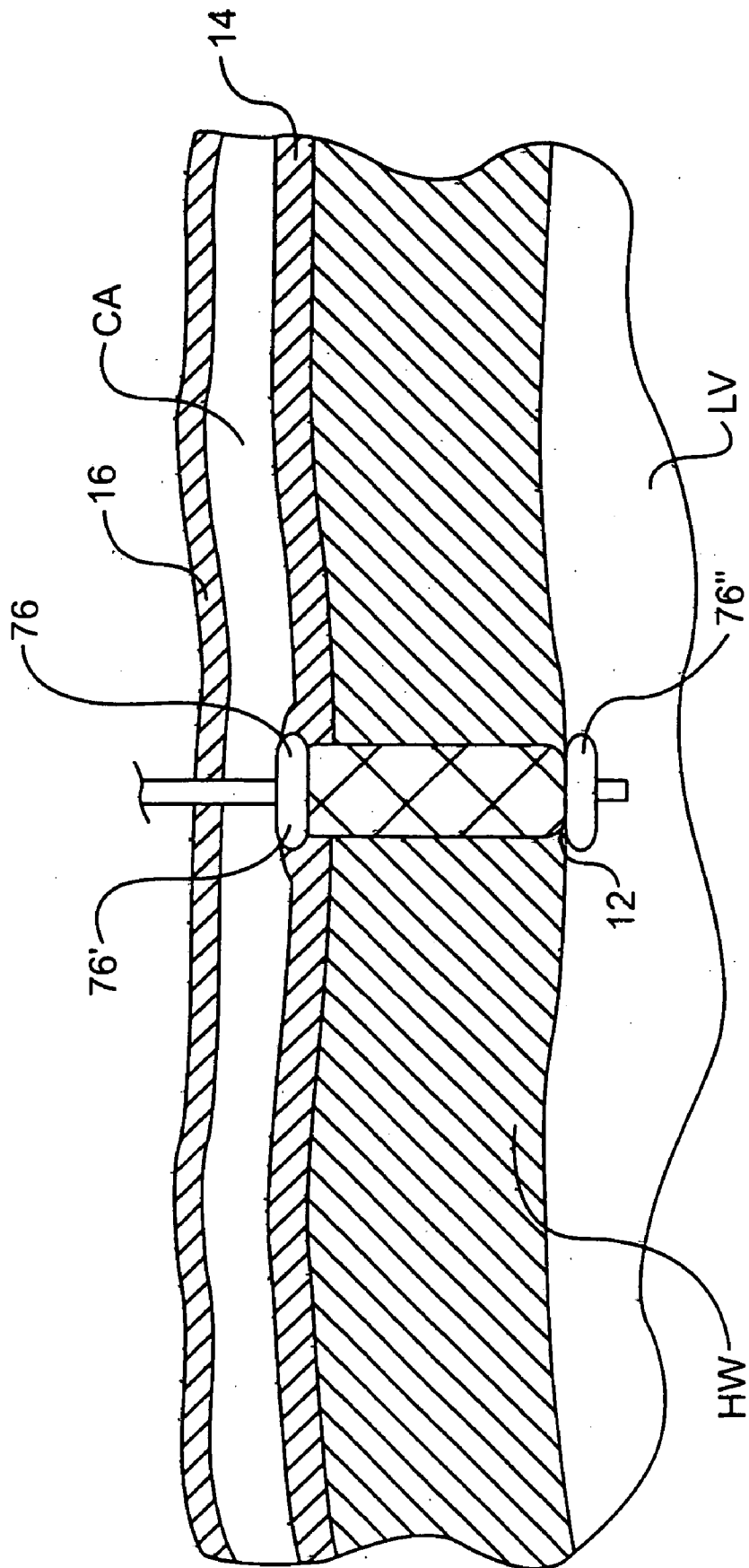
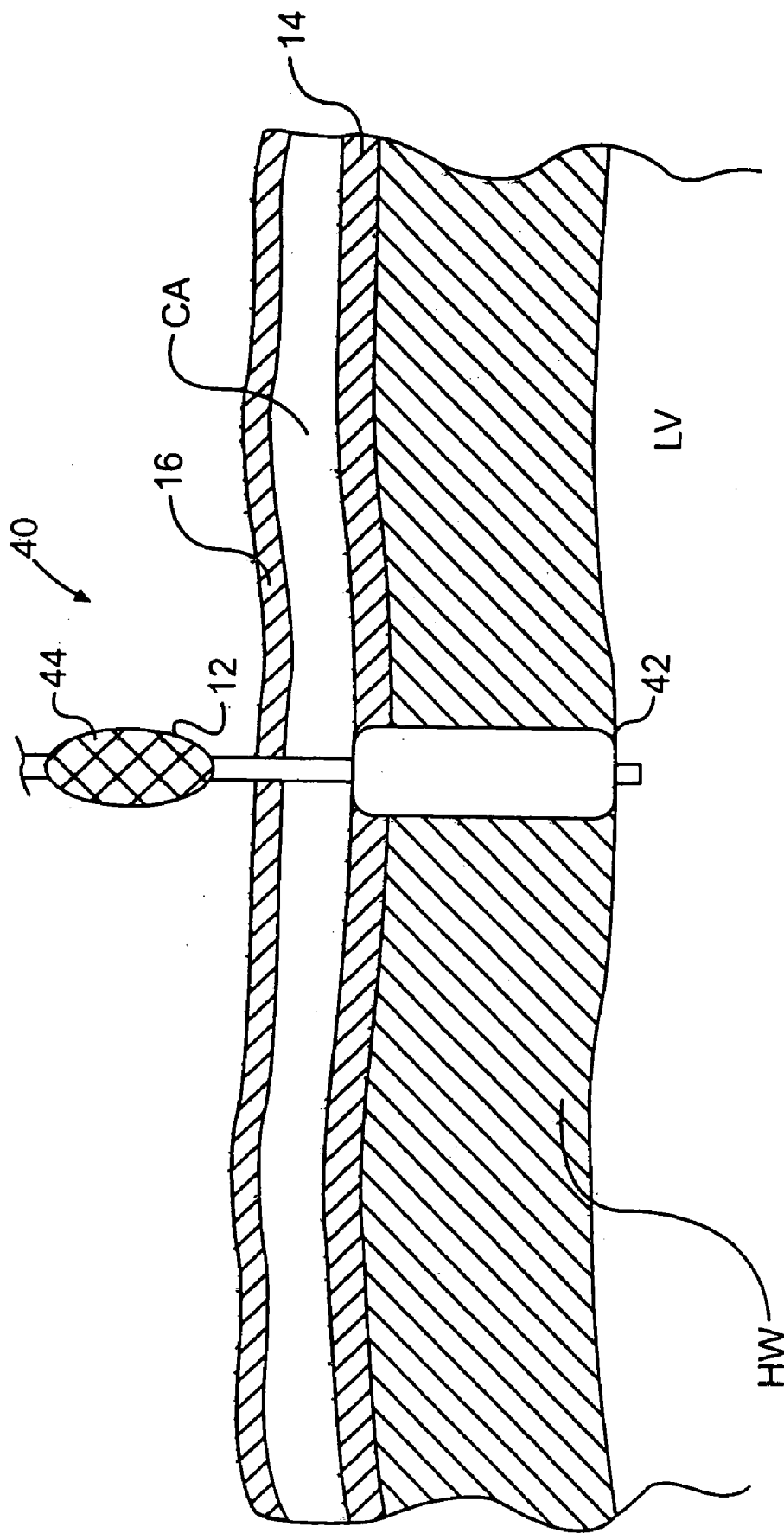


FIG. 7

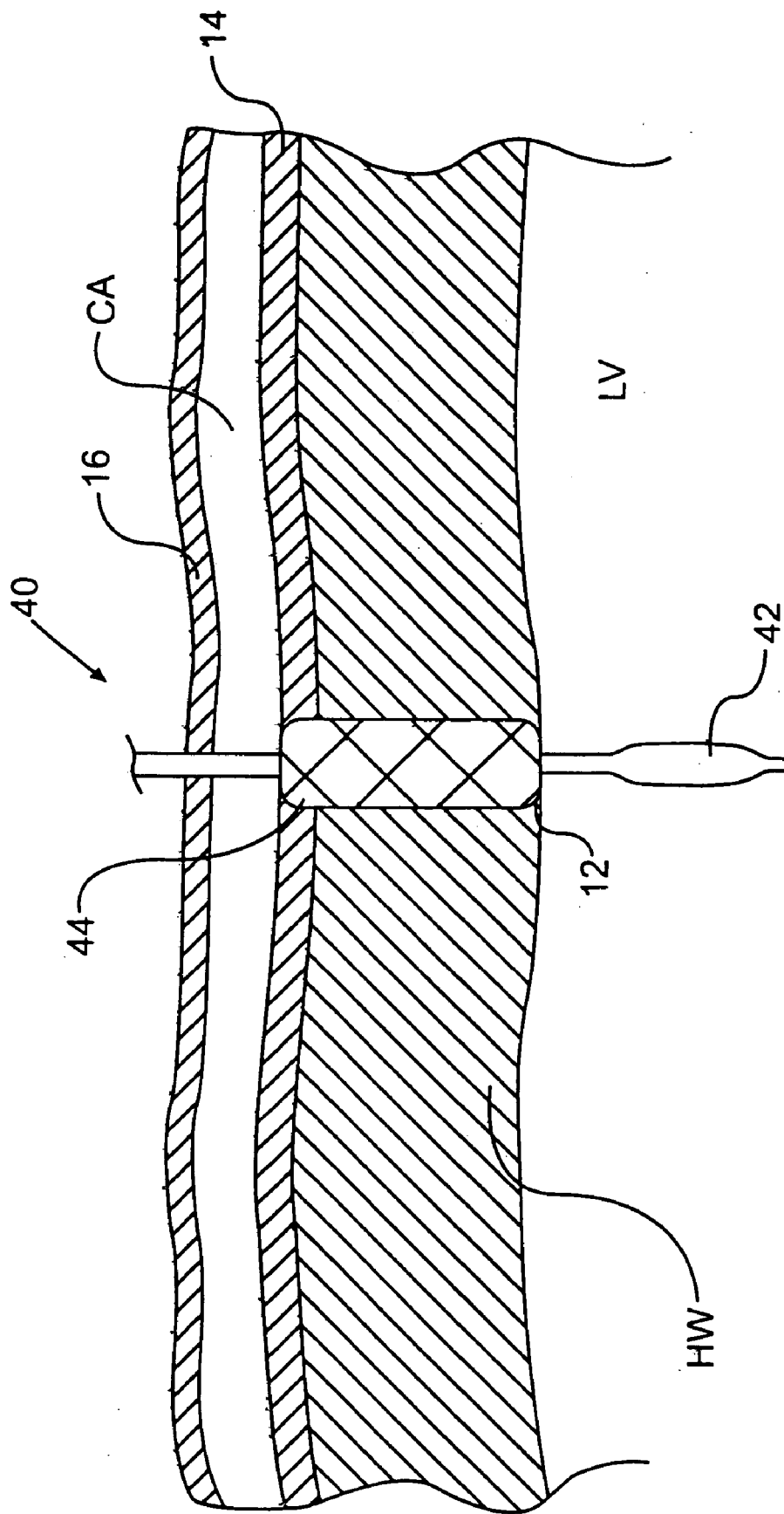




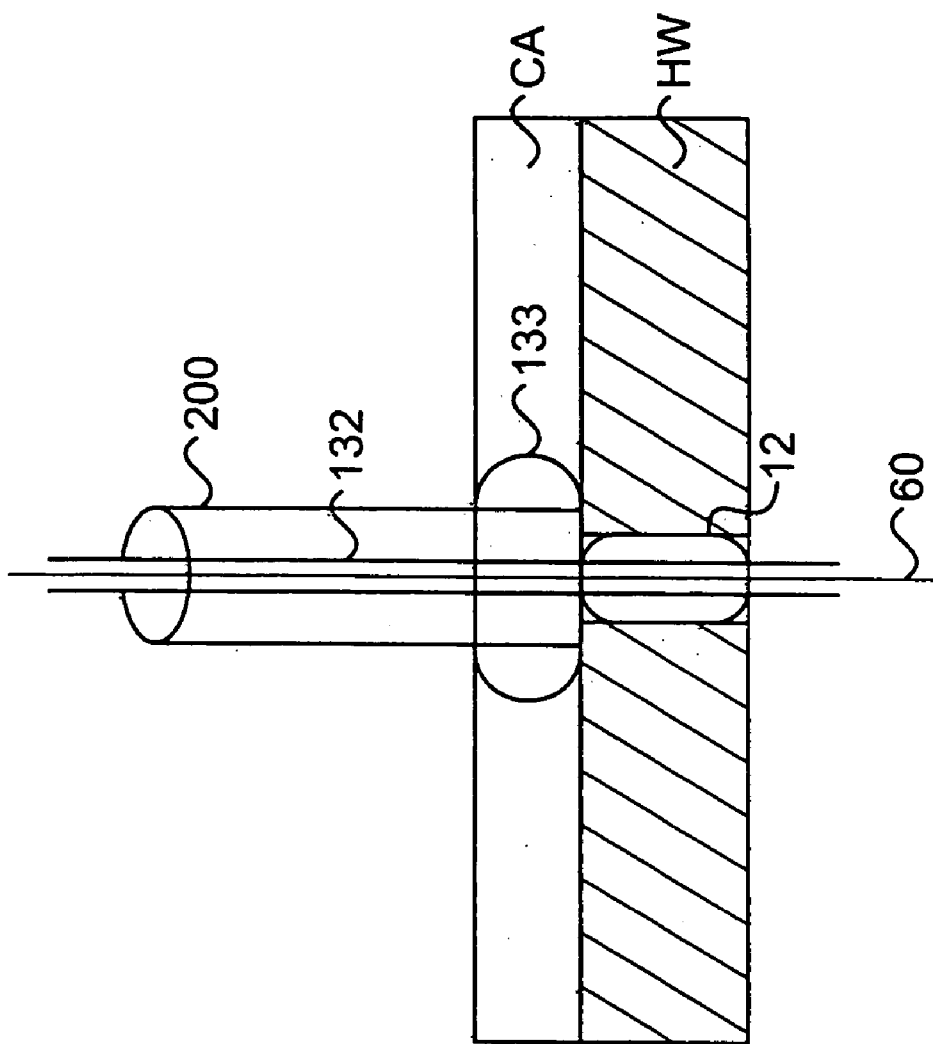
**FIG. 8**



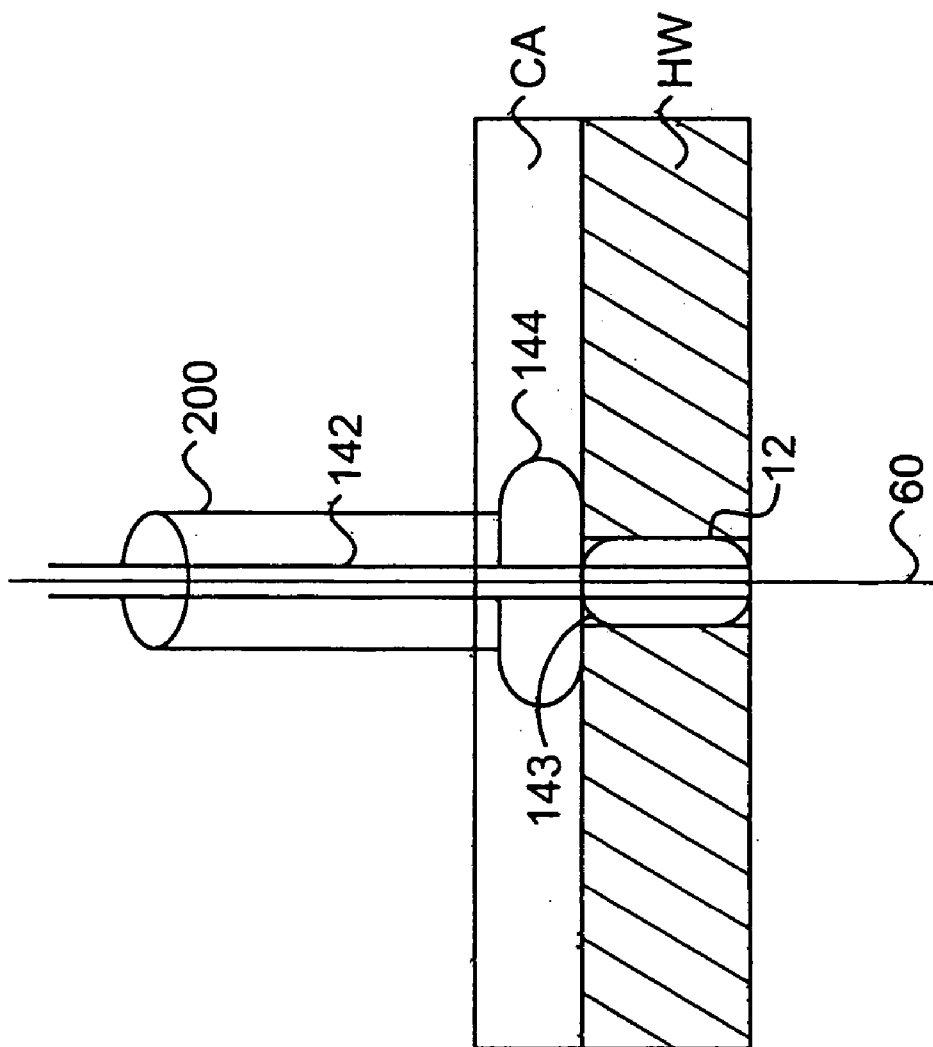
**FIG. 9**



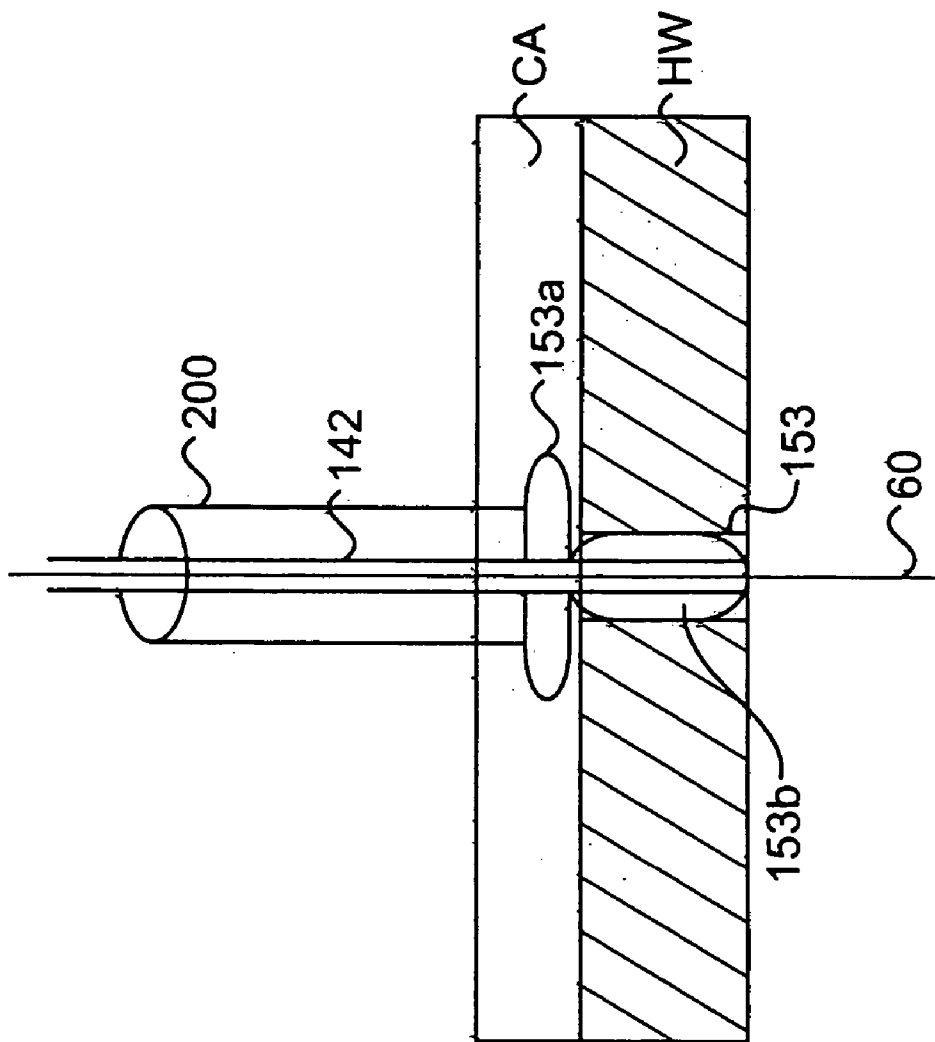
**FIG. 10**



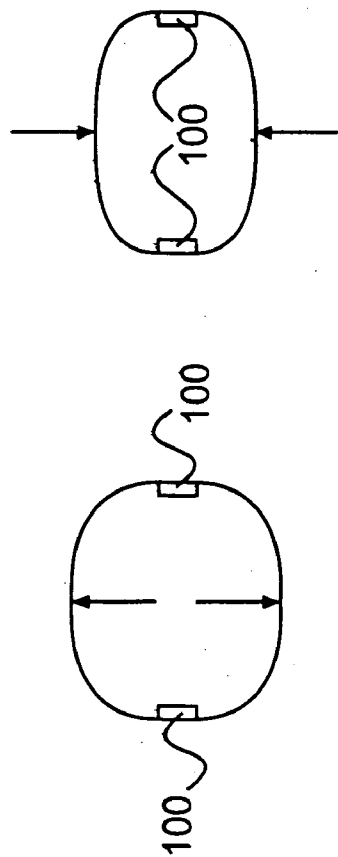
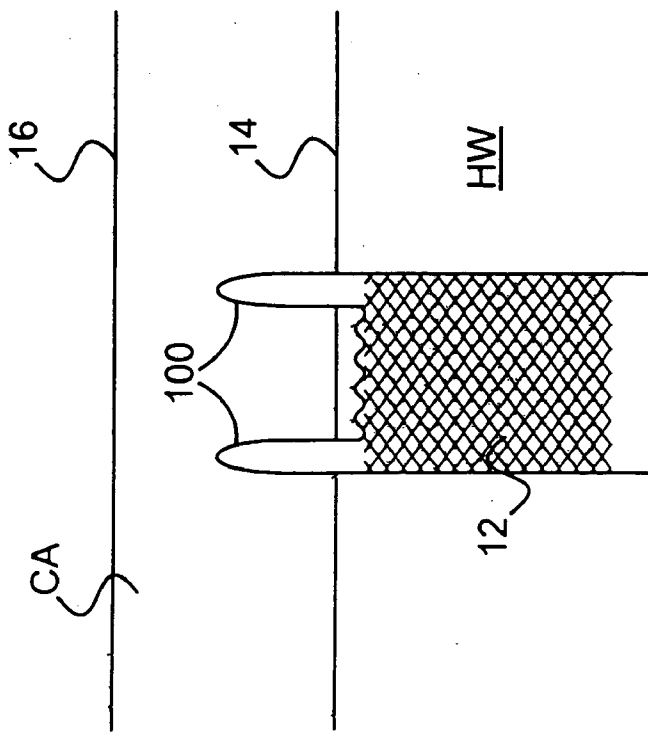
**FIG. 11**



**FIG. 12**



**FIG. 13**



**FIG. 15A** **FIG. 15B**

**FIG. 14**

## METHODS AND DEVICES FOR DELIVERING A VENTRICULAR STENT

### CROSS REFERENCE TO RELATED APPLICATIONS

[0001] This application claims the benefits of U.S. Provisional Patent Application Ser. No. 60/201,732, filed May 4, 2000.

### BACKGROUND OF THE INVENTION

#### [0002] 1. Field of the Invention

[0003] The present invention relates to methods and related devices for forming a passageway in a heart wall and delivering a stent therein to supply oxygenated blood flow to vascular structure from a chamber of the heart. For example, the methods and related devices preferably place a stent in the left ventricular heart wall in order to establish a supply of blood from the left ventricle to the coronary artery at a point distal a partial or total occlusion of the artery.

#### [0004] 2. Background of the Related Art

[0005] A prevalent form of heart failure involves the build-up of plaque on walls of various vascular structure, such as, for example, the coronary artery. The plaque that builds up on the walls can form either a partial or total occlusion in the artery. Such an occlusion may either limit or completely block blood flow through the artery, which typically enters through the aortic valve from the left ventricle. Because the coronary artery supplies blood to the various blood vessels within the muscle forming the heart wall, limiting or blocking of the blood flow through the coronary artery can result in damage to the heart muscle, such as, for example, necrosis. Necrotic tissue can lead to reduced cardiac function by diminishing the pumping capacity of the heart. In some instances, the diminished capacity of the heart can lead to heart attack.

[0006] Various techniques have been developed to treat this type of heart condition. For example, a surgical technique, referred to as coronary artery bypass grafting (CABG), involves removing a vein or portion thereof from the patient, usually from the femoral vein, and grafting the vein so as to connect portions of the coronary artery upstream and downstream of the occlusion. Thus, the blood flow is directed around the occlusion and through the vein graft so that the oxygenated blood can be delivered to the vessels in the heart wall. CABG generally is performed as an open surgery resulting in relatively long recovery times. Patients also often experience a large amount of discomfort resulting from harvesting of the veins to be used in CABG. Furthermore, the veins that are grafted to the coronary artery have a limited useful life.

[0007] Coronary angioplasty represents another form of treatment of arteries having occlusions that can be performed as an alternative to bypass surgery. In this technique, a balloon catheter is inserted percutaneously into the coronary artery. Once the catheter has been inserted such that the balloon is adjacent the occlusion being treated, the balloon is inflated to dilate the artery in the location of the occlusion. Often this technique involves inflating and deflating the balloon repeatedly to establish the desired dilation of the artery. This technique may include placing a stent in a collinear manner in the artery at the location of the occlusion

to maintain the proper dilation of the artery. Delivery of the stent can be accomplished by removing the dilation balloon catheter and then inserting a balloon carrying the stent. A multiple balloon stent delivery catheter may dilate the artery and place the stent in a single insertion of the catheter into the patient.

[0008] Another technique that has been used to bypass a partial or total occlusion of the artery includes implanting a stent, or otherwise creating a flow passage, in the myocardial wall between the left ventricle and coronary artery at a position downstream of the occlusion. In this technique, a portion of the blood pumped from the left ventricle flows directly into the coronary artery.

### SUMMARY OF THE INVENTION

[0009] The advantages and purpose of the invention will be set forth in part in the description which follows, and in part will be obvious from the description, or may be learned by practice of the invention. The advantages and purpose of the invention will be realized and attained by means of the elements and combinations particularly pointed out in the appended claims.

[0010] The present invention pertains to methods, and related tools for performing the method, of delivering a stent or other like-device to the heart to connect the left ventricle to the coronary artery to thereby supply blood directly from the ventricle to the coronary artery. In a preferred embodiment, a method may be used to bypass a total or partial occlusion of a coronary artery. The inventive method is relatively quicker and less invasive than other techniques as a result, for example, of the manner in which the device is implanted into the heart and the elimination of the need to harvest veins from the patient to perform a CABG. Moreover, the delivery technique according to an embodiment of the present invention facilitates connecting the ventricle and coronary artery via a stent, the technique ultimately reducing the risk of damage to the coronary artery, as will be explained.

[0011] An aspect of the invention includes a method to provide direct blood flow between a heart chamber and a coronary vessel. The method includes placing a guide device through an anterior wall and a posterior wall of the coronary vessel and through a heart wall between the heart chamber and the coronary vessel, forming a passageway in the heart wall at a location defined by the guide device, and placing a stent within the passageway. The method may include insertion of a hollow needle through the anterior wall and the posterior wall of the coronary vessel and through the heart wall, prior to placing the guide device. The guide device may be, for example, a guidewire or other suitable like guide mechanism. According to an aspect of the invention, placing the guide device includes inserting the guidewire through the hollow needle until an end of the guidewire rests in the heart chamber. The hollow needle may be removed after inserting the guidewire through the hollow needle.

[0012] According to another aspect of the invention, the method may also include measuring a depth of insertion of the hollow needle. The measuring may be accomplished by viewing markings on the hollow needle that indicate the depth of insertion of the hollow needle or determining a pressure differential between the heart chamber and exterior the heart chamber.



[0013] The method according to another aspect of the present invention also includes avoiding intracardiac structures during insertion of the hollow needle, and placing the guide device at a predetermined angle relative to the posterior wall of the coronary vessel, which may include inserting a hollow needle at the predetermined angle through the anterior wall and the posterior wall of the coronary vessel and the heart wall, prior to placing the guide device.

[0014] In an aspect of a method of the present invention, the passageway is formed with a dilation device, such as a sheath or an inflation device, which may be in the form of a balloon for example. Forming the passageway may include inserting a balloon into the location defined by the guide device and inflating the balloon. A catheter may carry the balloon over the guide device. The balloon is preferably deflated after forming the passageway and removed from the passageway after deflation.

[0015] In another aspect of the invention, a stent is placed with an inflation device. The inflation device may be a balloon that carries the stent, and placing the stent includes inserting the balloon and the stent within the passageway and inflating the balloon. A catheter may carry the balloon and the stent over the guide device.

[0016] In another embodiment of the present invention, the passageway is formed and the stent is placed by a catheter carrying a first inflation device and a second inflation device. The first inflation device may be a first balloon and the second inflation device may be a second balloon. The catheter is inserted over the guide device so that the first balloon is positioned in the location defined by the guide device. The first balloon is inflated to form the passageway and deflated after forming the passageway. The catheter then is further inserted over the guide device so that the second balloon is positioned in the passageway. The second balloon may carry a stent. The second balloon is inflated to place the stent within the passageway.

[0017] According to another aspect, the invention includes a method of providing direct blood flow between a heart chamber and a coronary vessel that includes inserting an inflation device through an anterior wall and a posterior wall of the coronary vessel and into the heart wall, inflating the inflation device within the heart wall to form a passageway between the heart chamber and the coronary vessel, and placing a stent within the passageway. Inserting the inflation device may include inserting the inflation device over a guide device extending between the heart wall and exterior the heart chamber and the coronary vessel.

[0018] Yet another aspect of the invention includes a device for measuring the depth of penetration from an anterior wall of a coronary vessel to a heart chamber. The device includes a hollow needle defining a lumen and having a distal end and a proximal end. A depth indication mechanism is disposed on an external surface of the hollow needle and a handle is disposed on the proximal end of the needle. The handle includes an inner portion in flow communication with the hollow needle and a portion of the handle is transparent so that blood from the left ventricle that enters the handle from the lumen of the needle can be observed.

[0019] According to yet another aspect of the invention, a device for placing a stent in a heart wall comprises a delivery tool configured to deliver the stent to a location within the

heart wall and a stop mechanism disposed on the delivery tool such that the stop mechanism is proximate at least one end of the stent during delivery of the stent. The stop mechanism may be configured to engage a surface to determine the placement location of the stent within the heart wall.

[0020] According to another aspect, the invention includes a device for placement in a passageway between a heart chamber and a coronary vessel. The device includes a hollow conduit and a plurality of extensions protruding from an end of the conduit the plurality of extensions can include a pair of extensions at opposite sides of the conduit.

[0021] The foregoing general description and the following detailed description are exemplary and explanatory only and are not restrictive of the invention, as claimed.

#### BRIEF DESCRIPTION OF THE DRAWINGS

[0022] The accompanying drawings, which are incorporated in and constitute a part of this specification, illustrate embodiments of the invention and together with the description, serve to explain the principles of the invention.

[0023] FIG. 1 is a cross-sectional view of a heart with a stent disposed in the heart wall between the left ventricle and coronary artery downstream of an occlusion in the coronary artery;

[0024] FIG. 2 is an embodiment of a positioning tool for use in a method according to an embodiment of the present invention;

[0025] FIG. 3 is an embodiment of a double-balloon catheter for use in a method according to an embodiment of the present invention;

[0026] FIG. 4 is a device according to an embodiment of the present invention for use in accessing a heart chamber through a coronary vessel and for measuring the depth of penetration from the coronary vessel to the heart chamber;

[0027] FIG. 5 is an embodiment of a guidewire placed, according to a method of the present invention, so as to provide access to the left ventricle through the coronary artery anterior and posterior walls;

[0028] FIG. 6 is an embodiment of a catheter carrying a dilation balloon and placed, according to a method of the present invention, over the guidewire of FIG. 5 with the dilation balloon inflated to form a passageway in the heart wall between the left ventricle and coronary artery;

[0029] FIG. 7 is an embodiment of a catheter carrying a delivery balloon loaded with a stent, with the delivery balloon inflated to expand the stent and deliver the stent to the heart wall between the left ventricle and coronary artery, according to an embodiment of a method of the present invention;

[0030] FIG. 8 is another embodiment of a catheter carrying a delivery balloon loaded with a stent, with the delivery balloon extending past the ends of the stent so as to form mechanical stops upon inflation of the delivery balloon, according to a method of the present invention;

[0031] FIG. 9 is an embodiment of a double balloon catheter of the type of FIG. 3 shown with the dilation balloon inflated to form a passageway in the heart wall

between the left ventricle and coronary artery, according to an embodiment of a method of the present invention; and

[0032] FIG. 10 is the embodiment of the double balloon catheter of FIG. 9 in an advanced position with the delivery balloon positioned in the heart wall and inflated to deliver the stent to the heart wall and the dilation balloon resting in the left ventricle in a deflated state, according to a method of the present invention;

[0033] FIG. 11 is an embodiment of a sheath having a mechanical stop on a distal end used to deliver a balloon catheter carrying a stent, according to a method of the present invention;

[0034] FIG. 12 is an embodiment of a sheath and a double balloon catheter having a proximal balloon configured to inflate substantially horizontally within the coronary artery to form a mechanical stop for stent delivery according to a method of the present invention;

[0035] FIG. 13 is an embodiment of a sheath and balloon catheter with a T-shaped delivery balloon for stent delivery according to a method of the present invention;

[0036] FIG. 14 is a stent having extensions at an end nearest the coronary artery, according to an embodiment of the present invention; and

[0037] FIGS. 15a and 15b each is a myocardial passageway having the stent of FIG. 14, as seen from the coronary artery during systole and diastole, respectively.

#### DESCRIPTION OF THE PREFERRED EMBODIMENTS

[0038] An aspect of the present invention includes a novel method of placing a stent within the heart wall between the left ventricle and the coronary artery to provide blood flow directly therebetween. The novel method generally includes the steps of establishing a position of a passageway between the left ventricle and the coronary artery, creating the passageway, and placing a stent in the passageway. Each of these general steps will be described in greater detail below.

[0039] Although the methods according to the invention will be described with reference to establishing direct blood flow between the left ventricle and left anterior descending coronary artery, connections between other heart structures and vessels to establish flow therebetween also are within the scope of the invention. In addition, the inventive methods may be used in other settings, aside from the heart, that require creating a passage or conduit and delivering a device into the created passage to establish direct flow communication between two volumes, especially between volumes that may be difficult to access.

[0040] FIG. 1 generally shows a cross-sectional view of a heart 10 implanted with a conduit 12, preferably in the form of a stent. As shown, conduit 12 extends between the left ventricular chamber LV and the coronary artery CA at a point downstream of an occlusion O of coronary artery CA. Conduit 12 preferably does not extend substantially into either the left ventricle LV or the coronary artery CA. The invention includes other possible connection positions between the left ventricle LV and coronary artery CA, such as, for example, an angled position of conduit 12 with respect to either the left ventricle LV or the coronary artery CA. It is important that the connection position is selected

so as to avoid interference with various structures in the heart, including the papillary muscles, chordae, and mitral valve.

[0041] Once implanted, conduit 12 extends from the posterior wall 14 of the coronary artery CA to the left ventricle LV. The posterior wall 14 refers to that portion of the arterial wall that interfaces with the heart wall. The anterior wall 16 of the coronary artery refers to a portion of the arterial wall that does not interface with the heart wall. In one preferred embodiment, conduit 12 lies substantially flush with the interface between posterior wall 14 of coronary artery CA and the exterior surface of heart wall HW surrounding left ventricle LV, as negative effects may result if conduit 12 protrudes into coronary artery CA or is recessed within the myocardium. For example, if conduit 12 protrudes too far into coronary artery CA, blood flow through coronary artery CA, as well as blood flow exiting conduit 12 may become disturbed, resulting in stasis. On the other hand, if conduit 12 is recessed within the myocardium such that a space remains between conduit 12 and posterior wall 14 of the CA, the space may become occluded with tissue, thereby preventing flow into CA.

[0042] The method according to an embodiment of the present invention includes forming a passage in the heart wall and implanting a conduit 12, preferably in the form of a collapsible stent, in the passage to establish direct flow communication between the left ventricular chamber and the left anterior descending coronary artery. In a preferred method of the present invention, a first step includes providing access to the location of the heart wall at which the stent 12 will be implanted. According to the invention, access to the heart wall surrounding the left ventricle LV is obtained from outside the coronary artery CA. A hollow needle 50, shown in FIG. 4, is used to puncture the anterior wall 16 of the coronary artery. Sharpened distal end 51 of needle 50 is advanced until it punctures the posterior wall 14 of the coronary artery at a position that coincides with the location at which the stent 12 will be implanted into the heart wall surrounding the left ventricle LV. Needle 50 is then inserted into and advanced through the heart wall HW until a reflux of blood into needle 50 occurs, indicating that needle 50 has entirely traversed the heart wall and entered the left ventricle LV. At least a portion of hollow needle 50 that remains external to coronary artery CA during insertion into the left ventricle LV, for instance a portion of handle 53, should be transparent to permit observation of the reflux of blood into the needle.

[0043] Insertion of the needle should avoid damaging or otherwise interfering with critical internal cardiac structures such as, for example, the papillary muscles, chordae, the mitral valve, etc. To avoid such damage, a visualization technique may be employed either prior to insertion of the needle or concurrently with the insertion of the needle. Such visualization techniques can include, for example, the use of transesophageal, intraventricular, intracardiac, or epicardial ultrasonic probes, or a combination thereof.

[0044] In a preferred form of the invention, the stent 12 will be implanted at an angle in the heart wall. The angle of the stent 12 to the heart wall preferably is chosen according to fluid flow analyses that seek to optimize the blood flow path from the left ventricle to the coronary artery and minimize energy losses due to poor entry and exit angles,

and the like. In the case of an angularly implanted stent, hollow needle **50** also will have to enter the heart wall at the appropriate angle. To properly angle hollow needle **50**, a positioning tool preferably is employed. A preferred embodiment of such a positioning tool is shown in **FIG. 2**. Positioning tool **20** is a hollow tube preferably made of a substantially rigid material. Positioning tool **20** includes a first portion **22** connected to a second portion **24** at a hinge **26**. First portion **22** has opposite ends **28, 30**, and second portion **24** has an end **32** opposing end **30** and another end not shown in **FIG. 2**. In use, portion **22** is inserted into the coronary artery and portion **24** extends outside of the heart with end **32** open and facing towards the posterior wall of the coronary artery and the heart wall. The user bends portion **24** relative to portion **22** at hinge **26** so that portions **22** and **24** are at an appropriate angle. The user then can insert the hollow needle through portion **24** and into the heart wall at the desired angle.

[**0045**] After hollow needle **50** has punctured both the anterior and posterior walls of coronary artery CA, and has traversed the heart wall to enter into left ventricle LV, it may be desirable to measure the depth of penetration of the needle and thereby determine the thickness of the heart wall from the depth of needle penetration. This determination will be used later when, for example, choosing an appropriate balloon length for forming a passage between the left ventricle and the coronary artery, and choosing an appropriate length conduit to place in the passage. Therefore, on its external surface, the needle is provided with a depth indication mechanism. A preferable depth indication mechanism includes providing graduated markings representing various lengths on a proximal end of the needle. Once the needle penetrates through the ventricular wall and into the chamber, causing a reflux of blood through the needle, the depth of penetration is measured by the marking adjacent the anterior wall of the coronary artery. To then determine the thickness of the ventricular wall, the diameter of the coronary artery at the insertion site must be subtracted from the depth of needle penetration. This coronary artery diameter may be determined preoperatively by appropriate imaging techniques. Preferably, the preoperative image will show the location of the occlusion, the appropriate location for insertion of the needle, and the coronary artery diameter at that location.

[**0046**] An alternative depth indication mechanism includes an indicator **52** slidably disposed on needle **50**. An example of such an indicator is shown in **FIG. 4**. Marker **52** defines an aperture through which needle **50** is inserted. The aperture preferably is sized such that marker **52** easily, yet controllably, slides along the length of the needle. That is, the aperture preferably is sized such that marker **52** frictionally engages with the needle and thus cannot slide along the needle unless a sufficient force is applied to the marker. Marker **52** abuts the anterior wall **16** of the coronary artery CA and slides along the length of the needle as the needle is inserted into the left ventricle LV. After needle **50** is removed, the depth of penetration is indicated by measuring the length from the distal end of needle **50** to marker **52**. As a further alternative, graduated markings could be provided on the needle along with the marker to assist in determining the depth of penetration. Again, the actual thickness of the ventricular wall is determined by subtracting the diameter of the coronary artery (which preferably is determined using a

visualization technique, such as echocardiography for example) from the depth of penetration measurement.

[**0047**] As a further alternative device and method for aiding the accurate determination of the depth of needle insertion, the needle may include a suitable pressure transducer at the tip of the needle. The pressure transducer would sense the pressure of the left ventricle to accurately indicate when the needle enters the left ventricle. Once such a pressure is indicated, the depth of penetration is determined by the graduated markings on the outside of the needle, as explained above.

[**0048**] After hollow needle **50** has been inserted through the coronary artery CA and heart wall, and into the left ventricle LV, such that a path having the desired angle and positioning relative to internal heart structures has been created, a guidewire **60** or other suitable guide device is placed within the lumen of hollow needle **50** and extended therethrough. The guidewire **60** preferably has a tip portion which is relatively flexible while the portion of the guidewire to be positioned in the myocardium preferably is relatively stiff. After the guidewire has been extended between the left ventricular chamber LV and external to the anterior wall of the coronary artery CA, the needle can be removed by sliding it off the guidewire. The placement of guidewire **60** allows a pathway to be maintained so that the myocardium and left ventricular chamber can be accessed from outside the heart. **FIG. 5** shows a suitable placement of guidewire **60** with respect to the heart after the needle has been removed.

[**0049**] The next step of an embodiment of the inventive method includes forming a passageway in the heart wall at the location in which stent **12** will be implanted. Preferably, the passageway will be formed using a dilation mechanism, and more preferably an inflatable dilation mechanism. The inflatable dilation mechanism can be positioned in the heart wall in a deflated configuration and then inflated to thereby dilate the heart wall, thus forming the passageway. A preferred inflatable dilation mechanism for forming such a passageway includes a balloon catheter **70**, such as the one shown in **FIG. 6**. The balloon catheter can be fed over the guidewire with a dilation balloon **71** in a deflated condition. Thus, the catheter carrying a deflated dilation balloon advances through the anterior and posterior walls of the coronary artery and into the wall surrounding the left ventricle. The catheter may be inserted until balloon **71** resides within the heart wall. Preferably, the balloon has a length corresponding to approximately the thickness of the heart wall, and more preferably greater than or equal to the thickness of the heart wall, as measured during insertion of the hollow needle with either the measuring devices described above or through the use of ultrasound or the like. If the length of the balloon is greater than the thickness of the heart wall, the balloon may be positioned such that the excess length extends into the ventricle. The diameter of the inflated balloon is chosen so as to approximate the dimensions of the stent, for example diameter and length, that is desired in the heart wall. To facilitate positioning of the catheter, and in particular the balloon, with respect to the heart wall, a visualization technique, such as ultrasound or fluoroscopy, for example, or a mechanical mechanism, such as a mechanical stop, which may be formed by the balloon itself as will be explained shortly, may be utilized.

[0050] Once the catheter has been advanced such that dilation balloon 71 resides substantially within the heart wall, an inflation mechanism (not shown) is actuated to inflate the balloon. Balloon 71 is inflated as necessary to dilate the heart wall, causing a passageway to be formed therein, as shown in FIG. 6. The balloon preferably is made of a semi-compliant material to impart the appropriate dilation force to the heart wall. Preferably, the balloon will be inflated to a diameter corresponding to less than the maximum inflation extent of the balloon. This amount of inflation preferably will correspond to the desired dimensions, diameter and length, of the formed passageway. After dilating the heart wall and forming a passageway having desired dimensions, the balloon is deflated and removed from the passageway and the heart wall.

[0051] After removing the dilation balloon, the next step includes delivery of the stent into the as-formed passageway using a suitable delivery mechanism. In a preferred embodiment of this step, an inflatable delivery mechanism carrying the stent, such as a delivery balloon with stent 12 loaded thereon, is inserted into the passageway formed in the heart wall. Preferably, the balloon carrying the stent 12 is deflated and stent 12 is a collapsible stent that will be in a collapsed state when loaded onto the deflated delivery balloon. The stent 12 can be held in place on the delivery balloon by inflation pressure or other suitable mechanism.

[0052] As with dilation balloon 71, delivery balloon 76 (shown in FIG. 7) also will be carried by a catheter inserted over the guidewire. As will be explained shortly, the catheter carrying the delivery balloon can be either the same catheter or a different catheter than that carrying the dilation balloon. In either case, the catheter will be moved relative to the heart wall such that the stent-loaded delivery balloon is positioned within the formed passageway in the heart wall. Again, visualization techniques, such as ultrasound or fluoroscopy, for example, or a mechanical mechanism, such as a stop, for example, may be utilized in order to facilitate accurate placement of the delivery balloon, and thus stent 12, within the passageway. After the delivery balloon has been accurately positioned within the passageway, an inflation mechanism, which may be the same or different inflation mechanism used for the inflation of the dilation balloon, is actuated to inflate the delivery balloon. Upon inflation of the delivery balloon, stent 12 is expanded from its collapsed configuration. Preferably, the delivery balloon will be inflated to an extent that allows stent 12 to be fully expanded to fill the passageway created by the dilation balloon, and the inflated dimensions of the delivery balloon correspond to the full expansion of stent 12. FIG. 7 shows the delivery balloon inflated to expand stent 12 so that it fills the passageway in the heart wall.

[0053] In an embodiment of the invention, the length of delivery balloon 76 exceeds the length of stent 12 while collapsed. Stent 12 may be loaded onto the delivery balloon such that the deflated delivery balloon extends beyond each end of stent 12, and preferably at least from the proximal end of stent 12. As a result of extending beyond both ends of the stent, the balloon can expand during deployment beyond the ends of stent 12 and attain a dumbbell-like shape. In this manner, as illustrated for example in FIG. 8, by manipulation of the catheter, the proximal end 76' of the inflated balloon can provide a mechanical stop against the posterior wall of the coronary artery so that the proximal end of stent

12 can be positioned within the passageway to lie substantially flush with the posterior wall. If the balloon also extends beyond the distal end of stent 12, the distal end 76" of the inflated balloon also can provide a mechanical stop against the heart wall so that the distal end of stent 12 can be positioned within the passageway to lie substantially flush with the heart wall. Positioning of stent 12 substantially flush with the posterior wall of the coronary artery and the heart wall is preferable, according to one embodiment of the present invention, as was explained above to reduce the amount of stasis that occurs along the blood flow path from the left ventricle to the coronary artery and to reduce the risk of hematoma formation between the stent and the posterior artery wall.

[0054] Other embodiments of the inventive method include using a sheath as a dilation mechanism to form the passageway in the heart wall and to deliver the catheter carrying the stent to the heart wall. In embodiments using a sheath, after positioning the guide device in the desired location in the heart wall, a sheath may be advanced over the guidewire and inserted through the coronary artery and heart wall. The sheath will dilate the heart wall to form the passageway. Graduated markings may be placed on the outside of the sheath to determine the depth of penetration in the heart wall. A stent to be delivered may be preloaded on a balloon catheter and inserted over the guidewire and through the sheath to the appropriate position in the heart wall.

[0055] In conjunction with this sheath delivery technique described above, various mechanisms, as shown for example in FIGS. 11-13, either alone or in combination, may be employed to facilitate appropriate positioning of the catheter and the stent with respect to the heart wall. In these embodiments of the invention, once the sheath has been inserted in the heart wall to dilate the heart wall and form the passageway, the sheath can then be retracted from the heart wall until a distal tip of the sheath resides within the coronary artery. Referring to FIG. 11, the distal tip of a sheath 200 may include an expandable basket 133 surrounding the distal opening of the sheath 200. Preferably, basket 133 is self-expanding, such as a nitinol basket for example, and has a diameter ranging from approximately 2 mm to approximately 3 mm. The basket 133 positions the distal tip of the sheath 200 in the coronary artery and fixes this position by engaging with either the posterior or anterior walls of the coronary artery to prevent sheath 200 from passing therethrough. Once the sheath 200 is positioned, the stent may be delivered to the heart wall by placing stent 12 just distal to the tip of sheath 200. The distance between the distal tip of sheath 200, positioned at the inner surface of the posterior wall of the coronary artery, and the top of stent 12 may be determined by graduated markings on a portion of a balloon catheter 132 carrying stent 12 and extending outside sheath 200.

[0056] After appropriate positioning of stent 12, a locking mechanism (not shown) on sheath 200 may be used to fix the position of catheter 132. Once stent 12 has been placed within the heart wall, sheath 200 and catheter 132 may be removed from the heart. To remove sheath 200, basket 133 first must be retracted or compressed.

[0057] FIG. 12 illustrates another mechanism which may be employed to facilitate the positioning of stent 12 within

the heart wall. In this embodiment, after sheath **200** is inserted into the coronary artery, a double balloon catheter **142** is inserted over guidewire **60** and through sheath **200**. Double balloon catheter **142** includes a distal balloon **143** carrying stent **12** and a smaller proximal balloon **144**. Proximal balloon **144** preferably has a diameter ranging from approximately 2 mm to approximately 3 mm. Once balloon catheter **142** is inserted such that proximal balloon **144** is past the distal tip of sheath **200**, proximal balloon **144** may be inflated. This inflation causes proximal balloon **144** to expand substantially in a horizontal direction past the distal opening of the sheath and to engage the anterior and posterior walls of the coronary artery. This holds the balloon catheter **142** in an appropriate position to place stent **12** within the heart wall. Distal balloon **143** can then be inflated to deliver stent **12**. By positioning the distal end of proximal balloon **144** adjacent the posterior coronary artery wall and knowing the distance between the distal end of proximal balloon **144** and the proximal end of stent **12** on distal balloon **143**, the depth of insertion within the heart wall may be determined.

[0058] FIG. 13 depicts the use of a T-shaped balloon in conjunction with a sheath delivery technique to assist in accurate positioning of stent **12** in the heart wall. In this embodiment, a balloon catheter **152** has a single T-shaped balloon **153**, with stent **12** being carried by the lower, vertically-extending portion of the balloon **153**. Sheath **200** is inserted, as described above, until the distal tip reaches the interior of the coronary artery. Balloon catheter **152** carrying stent **12** then is inserted through sheath **200** and over guidewire **60** until the upper, horizontally-extending portion **153a** of balloon **153** is past the distal tip of sheath **200** and is within the coronary artery. Inflating balloon **153** at this point creates a mechanical stop mechanism similar to small proximal balloon **144** discussed above. That is, the upper, horizontally-extending portion **153a** of T-shaped balloon **153** engages with at least the posterior wall of the coronary artery to appropriately position the lower, vertically-extending portion **153b** of balloon **153**, and thus stent **12**, within the heart wall. Once stent **12** has been delivered and placed within the heart wall, balloon **153** can be deflated and catheter **152** and sheath **200** removed.

[0059] Regardless of the delivery technique employed, stent **12** preferably will be selected such that, upon full expansion, the conduit will have dimensions that cause the passageway in the heart wall to remain open, thereby creating a permanent passageway between the left ventricle and the coronary artery. Moreover, stent **12** preferably will have a length that approximately equals or is greater than the thickness of the heart wall. More preferably, the length of stent **12** is large enough to allow a small end portion of stent **12** to reside in the left ventricular chamber in order to prevent invagination of the tissue around the opening of the stent. Even more preferably, the length of the stent may be chosen such that it covers the systolic depth of the heart wall measured from the posterior wall of the coronary artery to the inner surface of the left ventricular wall. This systolic depth may be determined using visualization techniques, such as echocardiography, for example. In any case, the length of the stent **12** to be used may be determined from the measurements of the heart wall determined previously, for example using the hollow needle, in combination with the determination of the coronary artery diameter using appropriate visualization techniques.

[0060] In addition, the stent preferably will be made of or coated internally with a material that prevents heart wall tissue, blood, and debris from prolapsing into the stent. Such a material may include a woven or a non-woven polymer that is compatible with blood and has low thrombogenicity, or other coatings to improve resistance to thrombus formation or tissue overgrowth. Coatings that enhance endothelial cell formation also are desired. Moreover, the stent may include a drug delivery coating. Other materials exhibiting these characteristics while also allowing deployment by the inventive method also are within the scope of the invention.

[0061] A further preferable feature of the stent to be implanted in the heart wall includes a flow controller disposed within the stent. Such a flow controller preferably would bias flow in the net forward direction, i.e., in the direction flowing from the ventricle to the coronary artery. Flow control mechanisms of this type include autologous vein sections, xenograft vein or valve sections, tilting disks, ball-in-cage valves, tapered shunt configurations, lobed duckbill flaps, mechanical poppets, pressure or electrically activated valves, and other suitable like mechanisms. Examples of various flow control mechanisms used with stents to create a net forward flow from the left ventricle to the coronary artery can be found in commonly-owned U.S. patent application Ser. No. 09/368,393, filed Aug. 4, 1999, and entitled, "Valve Designs for Left Ventricular Conduits." The entire disclosure of that application is incorporated by reference herein.

[0062] In another embodiment of a flow controller, a stent may be used to create a natural valving mechanism to reduce the potential occurrence of backflow of blood from the coronary artery to the left ventricle during portions of the cardiac cycle, particularly diastole. This will be described in connection with FIGS. 14, 15a, and 15b. To create a natural valving mechanism, stent **12** may include a pair of extensions, or struts **100**, extending beyond the end of the stent nearest the posterior wall **14** of the coronary artery CA, as shown in FIG. 14. Struts **100** preferably are approximately 180° apart from each other and each strut **100** may have a length of approximately 0.5 mm to approximately 1 mm. Struts **100** may be formed by removing portions of a stent between the struts or by any other suitable manner known in the art. Additional struts, or different placements or lengths of the struts, may be used. The stent used for creating a valving mechanism may be with or without additional struts as needed to keep the oval-shaped opening shown in FIGS. 15a and 15b patent. In addition, the stent may be placed so that the portion of the stent (not including the struts) ends somewhat below the posterior wall **14** of the coronary artery CA, particularly during the diastolic phase of the cardiac cycle.

[0063] This placement of the stent, along with the struts **100**, causes natural valving to occur, as described with reference to FIGS. 15a and 15b. These Figures depict the passageway containing stent **12** in the heart wall, as viewed from the coronary artery looking into the passageway. FIG. 15a shows the circular shape of that passageway during systole, and the position of struts **100**. The arrows in FIG. 15a depict the opening of the top of the passageway at the posterior wall of the coronary artery caused by the flow of blood from the left ventricle to the coronary artery. FIG. 15b shows an oval shape of the end of the passageway nearest the coronary artery during diastole. The posterior wall of the

artery flattens out around struts **100** due to a drop in diastolic pressure as compared to normal conditions because of the placement of the stent **12**. This causes the coronary artery to collapse during diastole, in turn causing the oval-shaped opening of the end of the stent disposed nearest the coronary artery as shown by the arrows in **FIG. 15b**. Thus, the depth of stent **12** being somewhat below the posterior wall of the coronary artery, in combination with struts **100** extending into the coronary artery, permits that posterior wall to at least partially close the passageway in the heart wall during diastole, restricting flow of blood back into the left ventricle from the coronary artery. In contrast, relatively rapid and extensive pressure rise during systole occurs due to increasing flow from the ventricular side. This causes the opening of the passage nearest the coronary artery to open to the position shown in **FIG. 15a**. It may also be preferable in certain embodiments to include a natural valve mechanism, like that shown in **FIGS. 14-15b**, at the end of the stent nearest the left ventricle.

**[0064]** Once stent **12** has been expanded and positioned in the passageway in the heart wall, the delivery balloon is deflated. The catheter carrying the delivery balloon can then be removed from the patient by sliding it over the guidewire. The guidewire also can be removed from the patient and the puncture site in the artery can be closed via conventional suturing methods and/or surgical sealants, or other suitable closure techniques and mechanisms. In certain embodiments, a closing device similar to those used and known to close a patent foramen ovale may be used. Also, the inner part of the closing device which covers the inner surface of the coronary artery may be constructed without any Dacron or covering material as long as the fixation of the closing device is maintained by suitable fixation members. An outer portion of the closing device, made for example of a biocompatible covering material like Dacron, may then be connected to the inner portion of the closing device to close the hole.

**[0065]** Alternatively, it may be possible to close the hole in the anterior wall of the artery by retracting the wall of the artery without any closing device. Such a technique would be similar to using a suture, but would not require assistance by the surgeon. For example, as the hole in the artery is formed by introducing a sheath over a wire, the tissue surrounding the hole is compressed around the sheath. After removing the sheath, this tissue will tend to cause a portion of the artery wall to retract to close the hole. To assist in this process, a small outer ring may be fixed to the outside surface of the artery. This outer ring may be formed of a suitable closure material, such as a suture or glue. The ring may be applied prior to removing the sheath, essentially using the outer surface of the sheath as an applicator. Once the ring is fixed to the outer surface of the coronary artery, the sheath may be removed. The ring may then retract the tissue surrounding the hole to close the hole in the coronary artery.

**[0066]** As discussed above, the steps of dilating the heart wall using a balloon catheter to form the passageway and implanting the conduit can be performed by using separate catheters for each step, a first catheter carrying the dilation balloon and a second catheter carrying the delivery balloon and stent. As an alternative, a single catheter carrying both a delivery balloon and a dilation balloon and stent in a collinear manner may be used. If two separate catheters are

employed, one carrying the dilation balloon and one carrying the delivery balloon, a catheter exchange technique is employed. That is, after the catheter carrying the dilation balloon has been employed to form the passageway in the heart wall, the dilation balloon will be deflated and the catheter will be slid along the guidewire and removed from the patient. Then, the catheter carrying the delivery balloon with the collapsed stent loaded thereon is inserted over the guidewire and into the correct position with respect to the heart wall, and the conduit is implanted as described above.

**[0067]** If a single catheter carrying both the dilation and the delivery balloons is employed, the method is performed in the following manner. **FIG. 3** shows an embodiment of such a catheter **40** having at least two colinear balloons, a first dilation balloon **42** at a distal end and a second delivery balloon **44** just proximal of dilation balloon **42**. **FIG. 3** shows just the distal end of catheter **40**. Both balloons are connected to suitable inflation mechanisms known in the art. The same inflation mechanism can be used to inflate both balloons or two separate inflation mechanisms can be used. A suitable, exemplary length of each balloon is approximately 30 mm, and a suitable, exemplary diameter of each balloon is approximately 2.5-3.5 mm. The deflated delivery balloon **44** is loaded with the stent, not shown in **FIG. 3**. The catheter **40** is inserted over the guidewire and advanced until the dilation balloon **42** resides within the heart wall in the manner described above with reference to the discussion of the deployment of the dilation balloon to form the passageway. Once properly positioned within the heart wall, the dilation balloon **42** is inflated to form the passageway, as shown in **FIG. 9**. After the passageway has been formed, the dilation balloon **42** is deflated and the catheter is further advanced until the delivery balloon **44** is positioned within the passageway, also as discussed above. In this position, the portion of the catheter **40** carrying the deflated dilation balloon **42** will come to a rest in the left ventricular chamber. To implant the stent in the passageway, the delivery balloon **44** is inflated, causing expansion of the stent to fill the passageway, as shown in **FIG. 10**. Once the stent expands so as to be in contact with the heart wall surrounding the passageway, the delivery balloon **44** is deflated and the entire catheter **40** removed from the patient. The guidewire can be removed as well, leaving only the stent remaining to form a permanent passageway between the coronary artery and the left ventricle. The multiple balloon catheter shown in **FIGS. 4, 9, and 10** may incorporate a delivery balloon of the type shown in **FIG. 8**.

**[0068]** In one aspect of the invention, the method includes using a multiple balloon stent delivery catheter of the type shown in **FIG. 3** to perform the dilation of the heart wall to form the passageway and the implantation of the stent in a single insertion of the catheter over the guidewire, as just described. Suitable multiple balloon stent delivery catheters are disclosed in U.S. Pat. No. 4,763,654 issued to Jang and entitled "Tandem Independently Inflatable/Deflatable Multiple Diameter Balloon Angioplasty Catheter System and Method of Use" and U.S. Pat. No. 5,725,535 issued to Hedge et al. and entitled "Multiple Balloon Stent Delivery Catheter and Method." The complete disclosures of these patents are incorporated by reference herein. The disclosed catheters include a distal balloon and inner and outer concentric balloons located proximal the distal balloon. In the method according to the present invention, the distal balloon is used to form the passageway by dilating the heart wall.

The stent in a collapsed configuration can be loaded onto the outer concentric balloon, and the concentric balloons can be used to deliver the stent into the passageway by inflating either one of the inner and outer balloons or both the inner and outer balloons consecutively. In this catheter, the outer balloon is configured to expand to a greater extent than the inner balloon. However, the inner balloon may be configured to expand to an extent large enough that allows the outer balloon, and thus the stent, to expand such that the stent fits the passageway formed by the distal, dilation balloon. The outer concentric balloon can optionally be inflated to further expand the stent and the passageway formed by the distal, delivery balloon if such expansion is needed.

[0069] Other embodiments of the invention will be apparent to those skilled in the art from consideration of the specification and practice of the invention disclosed herein. The specification and examples are exemplary only, with a true scope and spirit of the invention being indicated by the following claims.

1-71. (Cancelled).

72. A device for placing a stent in a heart wall, the device comprising:

a delivery tool configured to deliver the stent to a location within the heart wall;

a stop mechanism disposed on the delivery tool such that the stop mechanism is proximate at least one end of the stent during delivery of the stent, said stop mechanism being configured to engage a surface to determine the placement location of the stent within the heart wall.

73. The device of claim 72, wherein the delivery tool includes an expandable portion configured to carry the stent during delivery.

74. The device of claim 72, wherein the expandable portion is an inflatable portion.

75. The device of claim 74, wherein the inflatable portion is a balloon.

76. The device of claim 73, wherein the expandable portion is a balloon.

77. The device of claim 76, wherein a portion of the balloon forms the stop mechanism.

78. The device of claim 77, wherein the portion of the balloon forming the stop mechanism includes a portion of the balloon extending beyond at least one end of the stent.

79. The device of claim 78, wherein the portion of the balloon forming the stop mechanism extends beyond a proximal end of the stent.

80. The device of claim 77, wherein the stop mechanism is formed when the balloon is inflated.

81. The device of claim 76, wherein the stop mechanism includes a second expandable portion.

82. The device of claim 81, wherein the second expandable portion is a second balloon.

83. The device of claim 72, wherein the delivery tool includes a sheath.

84. The device of claim 83, wherein the stop mechanism includes an expandable portion on a distal end of the sheath.

85. The device of claim 84, wherein the expandable portion is made of nitinol.

86. The device of claim 84, wherein the expandable portion has a basket-like configuration.

87-88. (Cancelled).

89. The device of claim 72, wherein the surface is a posterior wall of a coronary vessel.

90. The device of claim 72, wherein the stop mechanism is configured to position a proximal end of the stent substantially flush with the surface.

91. The device of claim 72, wherein the surface is a heart wall.

92. The device of claim 73, wherein the expandable portion, when expanded, has a substantially dumbbell-like configuration.

93. The device of claim 84, wherein the stop mechanism extends beyond a distal end of the stent.

94. The device of claim 72, wherein the delivery tool is configured to form a passageway in the heart wall.

95. The device of claim 72, wherein the delivery tool includes graduated markings to determine a depth of penetration of the delivery tool into the heart wall.

96. The device of claim 72, wherein the delivery tool includes two expandable members.

97. The device of claim 96, wherein the expandable members are balloons.

98. The device of claim 96, wherein at least one of the two expandable members is configured to engage a posterior wall of a coronary vessel.

99. The device of claim 96, wherein at least one of the two expandable members is configured to be placed within the heart wall.

100. The device of claim 99, wherein the stent is disposed on the at least one of the two expandable members.

101. The device of claim 100, wherein the stent is expanded by expansion of the least one of the two expandable members.

\* \* \* \* \*