

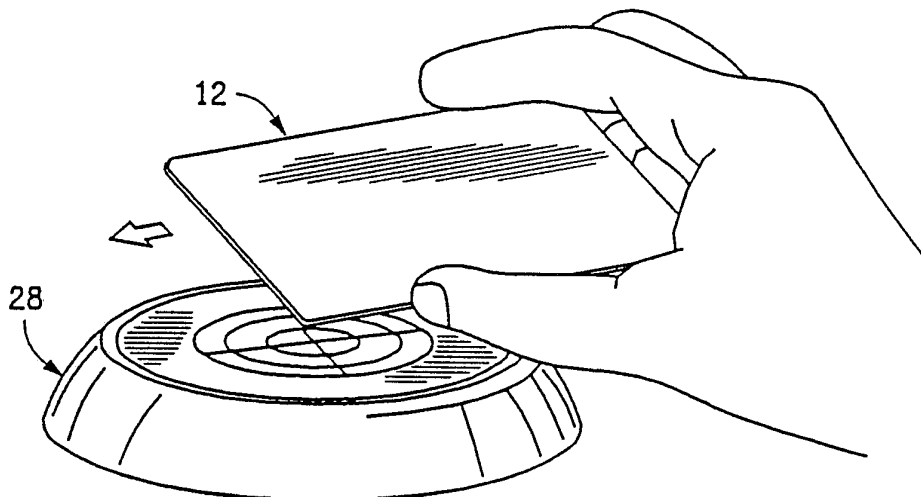

INTERNATIONAL APPLICATION PUBLISHED UNDER THE PATENT COOPERATION TREATY (PCT)

<p>(51) International Patent Classification ⁵ : G07B 15/00, G06K 7/08, 19/073</p>	<p>A1</p>	<p>(11) International Publication Number: WO 93/09516 (43) International Publication Date: 13 May 1993 (13.05.93)</p>
<p>(21) International Application Number: PCT/US92/08892 (22) International Filing Date: 19 October 1992 (19.10.92) (30) Priority data: 784,456 28 October 1991 (28.10.91) US (71) Applicant: CUBIC AUTOMATIC REVENUE COLLECTION GROUP [US/US]; 9333 Balboa Avenue, San Diego, CA 21086 (US). (72) Inventors: ROES, John, B. ; 2655 Poinsettia Drive, San Diego, CA 92106 (US). DE KOZAN, Raymond, L. ; 6643 Hilgrove Drive, San Diego, CA 92120 (US). WASSON, Warren, J. ; 708 G Avenue, Coronado, CA 92106 (US). TENTLER, Michael, L. ; 11427 Luz Road, San Diego, CA 92127 (US).</p>		<p>(74) Agents: BROWN, Carl, R. et al. ; Brown, Martin, Haller & McClain, 110 West C Street, Suite 1300, San Diego, CA 92101 (US). (81) Designated States: AU, CA, European patent (AT, BE, CH, DE, DK, ES, FR, GB, GR, IE, IT, LU, MC, NL, SE). Published <i>With international search report.</i></p>

(54) Title: NON-CONTACT AUTOMATIC FARE COLLECTION SYSTEM



(57) Abstract

An electronic transit fare card for use in an automatic fare collection system that is activated to pay the fare when brought into proximity with a coil mounted on access equipment at the entrance and exits of a transit system. The electronic fare card makes a non-contact communication connection with a target assembly by momentary coupling to a RF magnetic field carrier signal that is modulated either by a source impedance modulator on the card or by a target modulator. Both card and target assembly are shielded against electrostatic discharge (ESD) and unwanted radio transmission (EMI) by means of magnetically permeable electrostatic shields, thereby preventing the generation of unwanted radio transmissions and the accidental modifications of fare card data by ESD or stray radio signals. While our invention uses a coupled source impedance for modulation of a carrier signal, other modulation schemes may be used as known to those experienced in the art.

FOR THE PURPOSES OF INFORMATION ONLY

Codes used to identify States party to the PCT on the front pages of pamphlets publishing international applications under the PCT.

AT	Austria	FR	France	MR	Mauritania
AU	Australia	GA	Gabon	MW	Malawi
BB	Barbados	GB	United Kingdom	NL	Netherlands
BE	Belgium	GN	Guinea	NO	Norway
BF	Burkina Faso	GR	Greece	NZ	New Zealand
BG	Bulgaria	HU	Hungary	PL	Poland
BJ	Benin	IE	Ireland	PT	Portugal
BR	Brazil	IT	Italy	RO	Romania
CA	Canada	JP	Japan	RU	Russian Federation
CF	Central African Republic	KP	Democratic People's Republic of Korea	SD	Sudan
CG	Congo	KR	Republic of Korea	SE	Sweden
CH	Switzerland	KZ	Kazakhstan	SK	Slovak Republic
CI	Côte d'Ivoire	LI	Liechtenstein	SN	Senegal
CM	Cameroon	LK	Sri Lanka	SU	Soviet Union
CS	Czechoslovakia	LU	Luxembourg	TD	Chad
CZ	Czech Republic	MC	Monaco	TG	Togo
DE	Germany	MG	Madagascar	UA	Ukraine
DK	Denmark	ML	Mali	US	United States of America
ES	Spain	MN	Mongolia	VN	Viet Nam
FI	Finland				

-1-

NON-CONTACT AUTOMATIC FARE COLLECTION SYSTEM

BACKGROUND OF THE INVENTION

5 1. Field of the Invention

Our invention relates to a transaction system in which a portable token is used with a stationary target terminal to perform a financial transaction and, more specifically, a fare transaction system using battery-free fare card tokens that are shielded from electrostatic fields.

2. Description of the Related Art

15 Public transit systems have progressed from the mere purchase of a single ticket for a single ride to complex automatic fare collection systems. Present automatic fare collection systems use stored ride information, often stored in magnetic strip cards, which are contacted by a magnetic reading device that removes an appropriate fare from the stored fare data in the card. This reading device may also read other pertinent information from the card and write data such as new fare information back on the magnetic memory strip on the card. While these systems work well and are successful, they require the continual issuance of new cards and rely on mechanical contact with the cards at the points of entry and exit from the transit system. This mechanical fare card procedure must contend

-2-

with mutilated cards, misentry into the card receiving units, and mechanical failures in fare card reading and writing.

It has long been recognized that it would be of
5 considerable advantage to have an automatic fare
collections system in which the fare data is stored in an
electronic card that needs no mechanical contact with the
card processing systems at the entry and exit gates of
transit systems. Such electronic fare data would be read
10 by non-contact fare collection apparatus with no mechanical
contact between the fare card and the card information
processing systems. Such a fare card would merely be
passed near sensors at the entry and exit gates of the
transportation system, and all appropriate data concerning
15 fare, point of entry, point of exit, identification and
verification, fee for the ride, and other data would be
removed and reinserted into the fare card electronically,
without physical contact.

There are cards known in the art designated as "smart
20 cards" that contain data which may be selectively read by
an interrogating radio frequency (RF) radio transmitter.
These cards usually have passive information in the card
that identifies the card with a particular vehicle, or with
an article being shipped, or articles that are to be
25 identified. There are also other cards or articles which
resemble cards known in the that are capable of storing
information and repeating this information in response to
an RF radio interrogation signal transmitted from a
remotely located antenna. Such cards usually do not
30 contain a processor and thus cannot exchange information
with the interrogating station, write new data to the card,
nor verify the data transmission quality. Further,
existing smart cards may radiate unwanted RF radio signals
and are not adaptable for reliable use in automatic fare
35 collections systems because of extreme sensitivity to

-3-

electrostatic discharge (ESD) and stray radio signals (EMI) that may destroy or alter the financial data stored in the card.

For instance, U.S. Patent No. 4,501,958 issued to
5 John-Pierre Glize, et al., discloses a toll point
verification system that uses acoustic means for
communicating between a portable token and a toll point
verification terminal. Glize, et al., teach the use of a
terminal that emits repeated interrogation messages adapted
10 for triggering and reading the data contents of a memory
device within the token and they overcome the ESD and EMI
problem by using acoustic data transmission. The
reliability of the Glize, et al., system requires low power
beams for transmission and reception to avoid unwanted
15 disturbances to the memories of other portable tokens in
the vicinity, a significant disadvantage in public transit
queues.

U.S. Patent 4,571,589 issued to Chester D. Slocum, et
al., discloses a biomedical implant having a two-way
20 inductively-coupled data transmission path to an external
control terminal. Slocum, et al., use pulse-width
modulation (PWM) of an RF electromagnetic carrier to
transfer telemetry data at the high rates required for
real-time intracardiac (ECG) data transmission. Slocum, et
25 al., do not consider the problem of unwanted
electromagnetic radiation nor is their system adaptable for
use with a large number of smart cards or tokens.

U.S. Patent 4,650,981 issued to Wayne S. Foletta
discloses a smart credit card having active electronics
30 powered by a DC voltage derived from an electromagnetic RF
signal generated at a separate data terminal. Foletta
recognizes the problem of ESD effects on active memory
circuits but proposes no solution other than the use of
relatively insensitive active transistor technology
35 together with very small gaps between the credit card and

-4-

the credit card reader. Foletta's invention is not adaptable for use with non-contact fare card readers operating over distances greater than a few millimeters.

U.S. Patent 4,692,604 issued to Robert L. Billings
5 discloses a flexible inductor that permits contactless inductive power transfer from a stationary reader to energize electronics in a smart card. While Billing's flexible conductor invention permits such power transfer, it also exacerbates the smart card sensitivity to ESD and
10 EMI that may modify or destroy the data in smart card memory.

U.S. Patent 4,758,836 issued to Felice M. Sculli
15 discloses an inductive coupling system for bidirectional digital data transmission between utility meters and a portable transceiver. Sculli uses a single transformer with primary and secondary windings and couples the primary winding to an interrogation unit and the secondary winding to a transponder unit. Sculli requires repetition of a
20 "dead interval" to permit time for desaturation of his inductive transformer core between sequential transmit and receive operations, a limitation that prevents application of his teachings to a fare card system requiring full data exchange within a few dozen milliseconds.

U.S. Patent 4,782,341 issued to Bruce E. Gray
25 discloses another utility meter data gathering system that has a series of indexed contactors attached to the utility meter indicator dials. Gray uses inductive coupling to transmit a series of frequency-modulated (FM) data bursts from the data gathering device to a data collecting device,
30 but teaches data transfer in one direction only.

U.S. Patent 4,807,140 issued to Dominique C. Saulnier
discloses an electronic label information exchange system that uses several inductively-coupled tuned oscillators to transfer data from programmable memory in either direction,
35 from label to fixture and back again. Saulnier requires

-5-

his labels to pass as close as possible within range of a fixed transmitter and does not consider the problems of ESD, EMI, automatic data error correction and excessive handling over long periods of time such as are seen in a fare card system.

U.S. Patent 4,818,855 issued to Ronald W. Mongeon, et al., discloses a smart identification (ID) card system using magnetic coupling to transfer power to the smart ID card and modulated electromagnetic radiation to transfer data. Mongeon, et al., resolve the signal-to-noise (SNR) problem associated with combining power transfer and information modulation on the same signal by separating the signal transfer modes so that power is transmitted to the smart card by means of a magnetic field coupling and coded data is transmitted back to a fixed receiver by means of an electric field coupling. Mongeon, et al., do not consider the issues of bidirectional data transmission, ESD and EMI effects on smart card memory storage, nor the use of correction means for error-free data transfer.

U.S. Patent 4,827,115 issued to Yasuo Uchida, et al., an ID system using a tag or card data carrier that can be coupled electromagnetically to a stationary reading terminal. Uchida, et al., are concerned primarily with a method for recovering previously written data from the ID tag in the event of errors in writing new data to the tag and they teach the use of temporary memory means for achieving recovery of old data without considering methods for protecting ID tag data from ESD and EMI.

U.S. Patent 4,899,036 issued to John A. McCrindle, et al. disclose a transaction system employing portable tokens in cooperation with a fixed terminal. McCrindle, et al., teach the use of inductively-coupled data transmission in both directions between token and terminal using frequency-modulated operated (FM) carrier signals in one direction and amplitude-modulated (AM) carrier signals in the other

-6-

direction. McCrindle, et al., do not consider the problems of token memory loss because of electrostatic discharges and stray radio signals nor do they suggest means for correcting errors in data transmission, preferring to rely on the dual-mode scheme for the purposes first suggested by Mongeon, et al.

U.S. Patent 4,918,416 issued to Charles A. Walton, et al., disclose an electronic proximity ID that transfers data from ID card to terminal by detecting changes in ID card antenna reactance at the fixed terminal. Walton, et al., teach the use of antenna reactance changes as a power-efficient alternative to the use of antenna resistance changes known in the art.

Despite the extensive interest in non-contact fare card systems seen from the above discussion of existing patents, no practitioner has until now suggested a commercially useful solution to the problem of fare card memory integrity. Customer perception of fare card financial integrity is extremely important to the commercial success of any such fare card system. Even a single error in one million card transactions can lead to a deteriorating confidence in the system that ultimately leads to commercial failure. Thus, there is a strongly felt need to ensure the integrity of fare data stored in the fare card memory in the face of the well-known and universal effects of electrostatic discharges (ESD) and stray radio signals (EMI). These unresolved problems and deficiencies are clearly felt in the art and are solved by our invention in the manner described below.

SUMMARY OF THE INVENTION

It is therefore an object of our invention to provide a new and improved electronic fare collection card that is activated without RF radiation when brought into the proximity of a target mounted at the entry or exit gate of

-7-

a transit access system. We have invented such a new and improved electronic fare card and its coordinated operation in a transit access system.

In our invention, the electronic fare card has a relatively small size, comparable with that of a credit card. The card has an internal winding or coil that couples magnetically with a target winding in a target assembly that is mounted adjacent to the access gates of a transportation system.

The target winding, hereinafter also identified as "target antenna", is continuously driven by a RF carrier signal current. The normally inactive electronic fare card has a similar card winding. When the card is passed within about ten centimeters of the target antenna, the card winding couples with and loads the target antenna, forming a momentary transformer circuit. This momentary transformer circuit transfers data from the fare card to the target circuits through modulation of the target antenna radiation impedance by the fare card. Data transmission from the target antenna to the fare card is accomplished through modulation of the RF magnetic field amplitude by the target circuits.

In this coupled mode, data are transferred from the fare card memory to the target antenna circuits, which also provide for data verification of the data received as AM modulation of the carrier signal. Fare data transferred from the fare card can include the amount of stored rides, stored value of passes, special fare applications, identification of the cards, point of entry into the transit system and point of exit from the transit system and other related data used in automatic fare collection systems. The electronic fare card is also capable of receiving and processing new fare data, such as the reduction in stored fare for the ride just completed, from

-8-

the target antenna circuits. These data are read into the memory of the electronic fare card.

The fare card has means for sensing the magnitude of the coupling with the target antenna so that the card can normally be inactive and "turn on" only when passed near the target antenna. The fare card has a processor that not only passes the data in card memory through the card antenna to the target antenna, but also can do the mathematical computations necessary for the error correction method employing 16-bit Cyclical Redundancy Checksums (CRC). The system also retransmits upon detection of an error. The transmissions are normally completed in about 50 milliseconds, which allows the fare card holder to pass the fare card quickly over the target antenna to release the entry or exit gate for passage. The fare card may remain in a wallet and still make the momentary electrical engagement of transformer coupling.

The fare card is designed to be transparent to existing magnetic strip ticket readers and thus not disruptive to any existing automatic fare collections systems that use magnetic stripe cards or tickets. The momentary transformer coupling exists only between the fare card and the target antenna and can only occur when the two antenna windings are brought into proximity.

Both the card antenna and the target antenna are shielded against Radio Frequency Interference (RFI). This prevents interference with other electronic equipment and avoids the need for an FCC license for the fare cards. No contact with the fare card is required and it may be left in a wallet if brought close enough to the target antenna.

The fare card has a processor for implementing a highly reliable system for verifying data integrity. This results in a very low data exchange error rate and solves the problems related to customer dissatisfaction with

-9-

financial transaction errors. The fare card also has a passive impedance-modulation read-only transmission mode and cannot transmit data other than to the target antenna. Yet, the fare card has a full read-in capability.

5 The target antenna is connected to a transit system computer, which can identify the stored fare data from the fare card memory and thereby verify fare charges with the most current fare charge data tables held in the computer. This system computer can also identify missing fare cards
10 and provide other information to transit system processors relative to such fare cards and their use.

The fare card memory may have a memory means requiring no battery back-up power. The fare card electronics are completely passive, deriving all necessary power from the
15 momentary transformer coupling to the continuous RF magnetic field generated by the target antenna. Both the fare card and the target antenna assembly are completely shielding against the effects of stray RF radio signals (EMI) and electrostatic discharges (ESD). This improvement
20 is crucial to the practicality of our invention because ESD and EMI can act to change the data stored in the fare card memory, thereby destroying consumer confidence in the accuracy and reliability of what basically amounts to his money stored in a silicon chip. We have found through
25 extensive experimentation that a particular form of shielding is required to avoid unwanted start-up pulses in the fare card microprocessor as well as unwanted write pulses in the fare card memory circuits while still permitting the momentary coupling to the RF magnetic signal
30 current flowing in the target antenna. We have disclosed these special shielding methods and devices in copending patent application No. _____ entitled "Magnetically-Permeable Electrostatic Shield" filed concurrently herewith.

-10-

The foregoing, together with other features and advantages of our invention, will become more apparent when referring to the following specifications, claims and the accompanying drawings.

5

BRIEF DESCRIPTION OF THE DRAWINGS

For a more complete understanding of our invention, we now refer to the following detailed description of the embodiments illustrated in the accompanying drawings, wherein:

10 Figure 1 is a block diagram of the electronic fare card circuits;

Figure 2 is a block diagram of the target antenna circuits;

15 Figure 3 is a block and schematic diagram of the transit system that is connected to the target antenna circuits and target processor;

Figure 4 is a top plan view of the target antenna assembly;

20 Figure 5 is a sectional view taken along lines 5-5 of Figure 4;

Figure 6 is a top plan view with parts in phantom of the electronic fare card;

25 Figure 7 is a sectional view taken along line 7-7 of Figure 6;

Figure 8 is an illustration of the electronic fare card being moved over the target antenna assembly;

30 Figure 9 is a schematic diagram of the fare card circuits that process the transformer-coupled signals and start the fare card processor;

Figure 10 is a schematic diagram of the RF generating and processing portions of the target circuits; and

35 Figure 11 is a schematic diagram of an alternative embodiment of the fare card circuits requiring no battery power for the fare card memory circuit.

-11-

DESCRIPTION OF THE PREFERRED EMBODIMENTS

Referring to Figures 1-8, the electronic fare card 12 contains a card antenna 14 as seen in Figures 1 and 6. Fare card 12 comprises a printed circuit board (PCB) 16 having the card circuits 18 thereon. PCB 16 and card circuits 18 are surrounded by the Faraday shield 20, which comprise MYLAR® embedded with a conductive layer to form an electrostatic foil shield 20. Shield 20 is seen in Figure 7 as the upper side shield 20a and the lower side shield 20b. PCB 16 with shield 20 is then encapsulated in a plastic container having a top side 22, a lower side 24 and rounded edges 26. The size of fare card 12 will depend on the construction and intended use, but the size should be comparable with a credit card so that fare card 12 may be placed in a user's wallet (not shown). The wallet and fare card 12 may then be easily passed over the target assembly 28 shown in Figure 8 in accordance with the operation of our invention. A typical such fare card 12 would measure 55 mm by 86 mm by 4 mm and would weigh about 25 grams. Card antenna 14 is shown in Figure 6 as a coil having several turns laid around the edge of PCB 16. Card antenna 14 may typically contain 6 turns. Appropriate connections are made with card circuits 18 as illustrated in Figure 1.

Fare card 12 couples in its operation with target antenna assembly 28 as seen in Figures 4, 5 and 8. Target antenna assembly 28 comprises a plastic dome or target housing 30 having an inside layer of shielding, comprising MYLAR® and electrostatic foil shield 32, together with a target antenna 34, comprising a single coil connected to the separate electronic target circuits 36 as illustrated in Figure 2. Target circuits 36 provide a continuous RF signal current to target antenna 34.

Card circuits 18 shown in Figure 1 are normally in a deactivated or quiescent state when fare card 12 is first moved by a transit patron over the top of target housing 30

-12-

as illustrated in Figure 8. The target outline 38 seen on top of target housing 30 illustrates the target area for the transit patron. Card antenna 14, arriving in proximity to the RF magnetic field generated by target antenna 34, momentarily couples to target antenna 34 and transfers energy to card antenna 14 by means of the momentary circuit formed between antennas 14 and 34.

In our preferred embodiment, a 3 MHz magnetic field at target antenna 34 induces a 3 MHz signal current in card antenna 14 that is rectified by the RF rectifier circuit 40 to form the direct current (DC) voltage presented to the power supply (VCC) sensor circuit 42, as seen in Figure 1. Sensor circuit 42 is a comparator circuit that compares the magnitude of the induced DC VCC voltage to a fixed threshold. When VCC exceeds the fixed threshold, sensor circuit 42 presents a "power-up" signal to the reset circuit 44 that in turn sends a reset signal through the reset line 46 to the card microprocessor 48, thereby signaling card microprocessor 48 to begin executing the stored microcode.

Reset line 46 tells card microprocessor 48 that VCC rectifier circuit 40 has accumulated sufficient power induced from target antenna 34 to ensure an orderly shut-down sequence should the momentary transformer coupling between coupling antennas 14 and 34 be suddenly interrupted. Even in our alternate embodiment for fare card 12, wherein we provide a battery 50 and a battery status sensor 52 as shown in Figures 1 and 10, the power for operating card microprocessor 48 is taken from VCC rectifier circuit 40. Accordingly, it is very important to avoid accidentally triggering the start-up sequence of card microprocessor 48 without accumulated VCC power sufficient to ensure orderly power-down upon interruption of the VCC power supply. This is the purpose of sensor circuit 42 and reset circuit 44 and serves to avoid data loss or partial

-13-

memory modification caused by intracycle interruption of card microprocessor 48.

With card microprocessor 48 in operation, the RF carrier signal in card antenna 14 is presented to a modulation detector 54 that demodulates and detects the data imposed on the RF carrier signal current. Data communication from target antenna 34 to card antenna 14 is accomplished by amplitude modulation (AM) of the RF carrier signal current as will be described in more detail hereinafter. This AM is detected in detector 54, which converts the AM into a stream of digital data for processing by card microprocessor 48. Card microprocessor 48 proceeds under control of microcode from read-only memory (ROM) 56 to process the digital data stream from detector 54.

The first step in processing the digital data stream is the completion of error correction using a 16-bit Cyclical Redundancy Checksum (CRC) error correction technique. Following error correction, card microprocessor 48 confirms from the input data that fare card 12 has momentarily coupled to a valid target antenna assembly 28. Microprocessor 48 then reads out the digital fare data stored in read and write memory (RAM) 58 to the impedance modulator 60. A local oscillator (L.O.) synchronizer 62 also receives the RF carrier signal input and synchronizes the clock (not shown) in card microprocessor 48. Impedance modulator 60 modulates the source impedance of card antenna 14 and thereby modulates the load presented by the momentary transformer coupling to target antenna 34. Resulting changes in RF carrier signal current in target antenna 34 are detected by target circuits 36 as illustrated in Figure 2. Target circuits 36 are connected to target antenna 34, as previously described.

The target microprocessor 64 is in continuous operation and is driven by a target clock 66. Target

-14-

microprocessor 64 uses a clock signal 68 provided by clock 66, which may be any suitable crystal-controlled source, and divides clock signal 68 to provide the RF carrier signal to a target modulator 70. We prefer an RF frequency of 3 MHz. Target microprocessor 64 also presents a digital data stream to target modulator 70, which modulates the RF carrier signal current in target antenna 34 with the digital data stream. Target microprocessor 64 obtains the digital data stream from a RAM 72 and from other sources such as from the data switch 74 that accesses the RS-422 interface 76 and the RS-232 interface 78. RS-232 interface 78 is connected to a gate local processing computer (LPC) processor 80 that will be described in more detail below.

Modulator 70 then presents a modulated RF carrier signal to the RF amplifier 82, which forces an RF carrier signal current through target antenna 34. This RF carrier signal current is a continuous sinusoidal current in which the data from target microprocessor 64 is coded as a modulation of the RF current sinusoidal amplitude.

When card antenna 14 is in position to couple with target antenna 34, card circuits 18 are then powered-up in the manner previously described. Fare card 12 then transmits a data stream from card memory 58 by modulating the source impedance of card antenna 14, which, being coupled to target antenna 34, modulates the RF carrier signal current flowing in target antenna 34, as described above. It is an important feature of our invention that this impedance modulation process requires no electromagnetic radiation from card to target. At this time, the carrier current flowing in target antenna 34 is not modulated by target modulator 70. Accordingly, the RF carrier current in target antenna 34 is modulated only by the modulated impedance loading coupled from card antenna 14. This load variation causes an AM output from target antenna 34 to the target modulation detector 84. The AM is

-15-

converted by detector 84 to a digital data stream that is presented to target microprocessor 64. Microprocessor 64 operates in accordance with microcode stored in the ROM 86 and microprocessor 64 can write or read digital data in RAM 5 72 as mentioned above.

Target antenna assembly 28 can have any suitable size. An example of a suitable operational size is about 15 cm in diameter. We prefer locating target circuits 36 immediately adjacent to target antenna assembly 22, but 10 target circuits 36 may also be separately located in a suitable shielded box. When target circuits 36 provide the RF carrier signal current to target antenna 34, there is little RF radiation from target antenna 34 because the electric field is shielded by target shield 32, as shown in 15 Figure 5. This shielding effect also applies to fare card 12, which is shielded by card shield 20, as shown in Figure 7.

Electrostatic shields 20 and 32 are an important element of our invention because they solve problems known 20 in the art for which no solution has heretofore been proposed. Data communication between fare card 12 and target antenna assembly 28 is possible only because the two antennas 14 and 34 momentarily form a transformer coupling in which the RF carrier signal current flowing in target 25 antenna 34 is amplitude modulated in two ways. First, target modulation 70 adds target data modulation to the RF signal current flowing in target antenna 34. Secondly, the modulated impedance load presented to target antenna 34 by card antenna 14 adds card date modulation to the RF carrier 30 signal current fed from RF amplifier 82 to target antenna 34. This coupled impedance modulation is detected by target modulation detector 84. The proximity of fare card 12 to target antenna assembly 28 will facilitate the momentary transformer coupling and thus limit the range of

-16-

data transmission between fare card 14 and target antenna assembly 28 to the 15 cm typically desired.

Card shield 20 and target shield 32 must be opaque to electrostatic fields while also being somewhat transparent to magnetic fields. In copending patent application No. 5 _____ entitled "Magnetically-Permeable Electrostatic Shield", one of us discloses permeable electrostatic shielding methods and devices suitable for this fare card system application. Briefly, if shields 20 and 32 comprise a flexible plastic support layer, such as MYLAR® or the like, that is coated by a vacuum deposition 10 technique or the like with an excellent conductor such as copper, brass or aluminum to a thickness of 10-20 nm, then the resulting shield will effectively block transmission of electrostatic fields while still permitting the penetration 15 and transmission of RF magnetic fields at RF frequencies up to 15 MHz. The general rule that one of us has discovered for such a solid metal-coated shield is that the thickness of the solid metal layer should be no more than 10-20% of 20 the skin penetration depth for the particular metal and frequency involved. This method is practical for all magnetic field frequencies below 15 MHz. Above this frequency, the metal layer thickness must be so thin that the electrostatic shielding effectiveness is degraded 25 unacceptably and a comb or cross hatch metallized pattern must instead be used to provide the magnetic permeability required, as is disclosed in the copending patent application referenced above.

During normal operation, referring to Figures 1-8 and 30 particularly Figure 2, target antenna assembly 28 is generating a continuous RF carrier magnetic field signal, by virtue of a continuous RF carrier signal current in target antenna 34, and target microprocessor 64 is listening for a response in the form of external modulation 35 of the RF carrier signal current in target antenna 34.

-17-

Card microprocessor 48 in fare card 12 is asleep with ticket fare data being retained in RAM 58, which may be either battery-supported memory or electrically-alterable ROM requiring no battery. Card microprocessor 48 will remain asleep because it has not yet received sufficient power through RF rectifier VCC circuit 40. Fare card 12 would normally not see any power until a magnetic source is brought close enough to provide the requisite momentary transformer coupling with card antenna 14. Even if power is accidentally supplied through VCC circuit 40 to card processor 48, fare card 12 will still not see the appropriate modulated data at card modulation detector 54 to which it can respond.

During this quiescent state of the fare card system, fare card 12 is brought into momentary transformer coupling range of target antenna assembly 28 and passed over the top of target antenna 34 as illustrated in Figure 8. The RF carrier signal current passing through target antenna 34 is magnetically coupled to card antenna 14 and the voltage induced in card antenna 14 is then rectified by RF rectifier VCC circuit 40. When the VCC power supply voltage output from VCC circuit 40 reaches a preset threshold value (for example, 5 volts) as determined by VCC power supply sensor circuit 42, reset circuit 44 causes a reset signal through reset line 46 to turn on card microprocessor 48. If fare card 12 is not coupled to target antenna assembly 28 for longer than 50 ms, as sensed through sensor circuit 42, reset circuit 44 then shuts down card microprocessor 48 and no ticket fare data is transmitted. The user is alerted to this circumstance by failure of the gate to open and by the absence of a green indicator light (not shown) mentioned below. Because fare card 12 is always in motion over target antenna assembly 28, the system does not continue operating after fare card 12 is moved away from the target range. Reset circuit 40

-18-

will generate an interrupt signal that shuts down card microprocessor 48 even if microprocessor 48 has not completed its operation. This is necessary to prevent loss of ticket fare data stored in card RAM 58. If card microprocessor 48 has already completed its operation, then, by its own control program, it will shut itself down as described below.

Card microprocessor 48 first reads the microcode stored in ROM 56 and proceeds to execute the program sequence in 20 ms blocks separated by 10 ms time gaps. Card microprocessor 48 next transmits the appropriate ticket fare data through impedance modulator 60 at a rate of 20 ms of ticket fare data every 30 ms. Target antenna 34 receives the ticket fare data in the form of radiation impedance fluctuations induced in target antenna 34 and detected in target modulation detector 84, which feeds the digital ticket data to target microprocessor 64, as shown in Figure 2. Target microprocessor 64 then activates an indicator light control 90 through an indicator control line 92, turning on a red light (not shown) at target antenna assembly 28, indicating that a momentary data coupling has been made. Target microprocessor 64 then verifies the data integrity and sends a hold instruction to card 12 through target modulator 70 and RF amplifier 82 by modulating the amplitude of the RF carrier current flowing in target antenna 34. Card antenna 14 senses the AM magnetic field emanating from target antenna 34 and thereby receives the hold instruction, which has the effect of directing card microprocessor 48 to stand by for further transmission of data.

When target microprocessor 64 checks for errors in data transmission, it uses a standard CRC method. The CRC is calculated for the ticket fare data received from fare card 12 and verified. If the CRC verification fails, target circuits 36 repeat the CRC procedure. If the CRC is

-19-

never verified, then the data transmission is eventually terminated by reset circuit 44 on fare card 12 as will be explained below.

Following CRC verification of data integrity, target
5 circuits 36 then send the hold instruction mentioned above, which instructs fare card 12 to end data transmission so that target circuits 36 can process the ticket fare data already transmitted concerning fare, card identification and other related information. After receiving the hold
10 instruction, fare card 12 ceases data transmission for 100 ms. During this 100 ms, target processor 56 processes the ticket fare data, in cooperation with gate LPC processor 80, through target RAM 72. Target microprocessor 64 then transmits new fare data to fare card 12 to update the
15 ticket fare data stored in card RAM 58. These new fare data can include a reduced ticket value reflecting the amount paid for the current ride and are received on fare card 12 through card antenna 14, processed by card modulation detector 54 and presented to card microprocessor
20 48 for CRC error correction and storage in card RAM 58. Again, this transmission is subject to the CRC verification of data integrity, which is verified for every transmission in either direction. In this direction, the CRC verification of the fare data stream is performed by card
25 microprocessor 48 on fare card 12.

Target circuits 36 then pass the ticket fare data received from target microprocessor 64 through data switch 74 and RS-232 interface 78 to gate LPC processor 80. LPC processor 80 checks the ticket fare data for conformance to
30 the fare table rules stored therein and generates new ticket fare data for storage in RAM 58 on fare card 12. LPC processor 80 can also pass new fare data to target circuits 36, which then can transmit these new data to fare card 12.

-20-

Fare card 12 receives the new fare data and stores them in RAM 58 during a fare card read operation following CRC verification of integrity. Card microprocessor 48 then initiates and sends an acknowledgement message (ACK) back to target circuits 36 by way of target antenna 34 and card microprocessor 48 then shuts down, returning to the initial quiescent state.

Target circuits 36 receive the ACK message and switch the target housing indicator light (not shown) from red to green by means of a signal through an indicator control line 92 to light control 90. Target circuits 36 then pass a credit information signal to gate LPC processor 80, which opens the transit access gate (not shown). The green indicator light generally extinguishes after about one second. Fare card 12 is then moved from the target range and power is thereby removed from card circuits 18, which are already asleep. The system returns to its quiescent state wherein target circuit 36 generates the RF carrier signal current through target antenna 34 and target modulation detector 84 listens for a response.

This system comprising fare card 12 and target antenna assembly 28 is particularly adapted for use in transit fare collections systems such as that illustrated in Figure 3, where gate LPC processor 80 receives the ticket fare data as above described through a gate data line 94 from target circuits 36. LPC processor 80 then sends appropriate ticket fare data to the station computer 96(a), of a plurality of station computers 96, to initiate the opening or closing of an automatic access gate 98(a), of a plurality of automatic access gates 98. These fare data may also be transmitted through a regional data line 100 to the operations control center computer 102, where the fare data may be stored in a storage medium 104 displayed at a terminal 106 or used to instruct a ticket generator 108.

-21-

Figures 9-11 present alternate embodiments of the functional electronics discussed above in connection with Figures 1-8. Referring to Figure 9, a schematic diagram illustrates the operation of transmit modulator 70, RF amplifier 82, target antenna 34, and target modulation detector 84. The RF carrier signal is coupled through the line 110 to a signal squaring circuit 112, which sets the signal voltage level to about 5 volts at the line 114. The digital data stream from target microprocessor 64 is coupled through a line 116 to a diode modulator and resistive mixer that transform the digital data stream to an amplitude modulated RF carrier signal at the line 118 that is mixed at the divider 120 to establish the magnitude of the amplitude modulation. A voltage divider circuit 122 adjusts the voltage level of the modulated RF signal in the line 124. The amplifying circuits 126 and 128 amplify the modulated RF carrier in line 124. A current divider 130 and a power amplifier circuit 132 generate the necessary modulated RF carrier signal current for energizing target antenna coil 34 through the antenna line 134. A power regulator 136 provides VCC power for the target logic circuits. The RF AM signal current flowing in target antenna 34 creates a RF AM magnetic field adapted for transformer coupling to card antenna 14 in the manner disclosed above.

In a target receive mode, unmodulated RF carrier signal current flows through antenna line 134 and target antenna coil 34. This unmodulated current is then modulated by the effects of the momentary transformer coupling to impedance modulator 60 on fare card 12, which is operating in a data transmission mode. The impedance modulation of the AM RF magnetic field from target antenna 34 induces amplitude modulation of the RF carrier current flowing through line 134 from current divider 130. The modulated RF carrier signal current at current divider 130

-22-

is presented to a capacitive divider 138 and therefrom to a detector circuit 140, which separates the AM frequency components from the RF carrier signal frequency. A filter 142 removes the RF carrier and the AM alone remains at the line 144. The AM signal at line 144 is then demodulated by comparison with the power output from a threshold source 146. The demodulation process generates a digital data stream by comparing the AM signal in accordance with the preset threshold provided by threshold source 146 at the comparator 148. A standard digital data pulse output at the data output line 150 corresponds to target modulator detector 84 output to target microprocessor 64 in Figure 2. Data output line 150 provides the digital ticket fare data received from fare card 12.

Referring now to Figure 10, a schematic circuit and block diagram illustrates the general operation of an illustrative embodiment of fare card circuits 18. During operation, card antenna 14 is moved into a momentary transformer coupling with target antenna 34 at target antenna assembly 28, as seen in Figures 1-8. The RF magnetic field carrier signal transfers power from target antenna assembly 28 to fare card 12 by means of the momentary transformer coupling at card antenna 14. A capacitor 152 has a capacitance value selected to tune card antenna 14 to the frequency of the RF magnetic field carrier signal, allowing card antenna 14 to couple the necessary power and signal from target antenna 34 while still removed some distance.

The RF carrier signal received at card antenna 14 is fed through a line 154 to the rectifier diode 156. The rectified carrier signal is filtered by a capacitor 158 to provide a DC output voltage at the lines 160 and 162. This VCC electrical current at line 162 passes through a current limiting resistor 164 and a sensing resistor 166 to a diode 168. Resistor 164 has a large resistance for effective

-23-

current limiting. A filtering capacitor 150 removes the modulated RF from the VCC power, which is also fed through a line 172 to the input of the comparator 174 and through a line 176 to the comparator 178. There is essentially no current flow initially in line 162 and so the VCC power supply voltage rises rapidly at first, normally within 1-2 ms, to about 5 volts DC. The zener diode 180 is selected to conduct at 5.1 volts and thereby limits the VCC voltage in line 182 to 5.1 volts, which voltage is then presented at the VCC line 184 as the general VCC power supply for the operation of card microprocessor 48.

In initial operation, comparator 174 senses the voltage drop across sense resistor 166. When this voltage drop is sufficient to force zener diode 180 into conduction, the increased voltage drop across sense resistor 166 is sensed by comparator 174, which provides a reset (wake-up) signal through a blocking capacitor 186 in the reset line 188 to card microprocessor 48. Card microprocessor 48 then powers up using the VCC current supplied through VCC line 184.

If the momentary transformer coupling is interrupted and VCC at line 162 drops below the 5.1 volt threshold established by zener diode 180, the current flow through sensing resistor 166 is then interrupted. This interruption is sensed by comparator 174 and its associated circuitry, which causes comparator 174 to terminate the signal in reset line 188. Card microprocessor 48 responds to the termination of the signal in reset line 188 by shutting down. At this point there is sufficient residual charge remaining on blocking capacitor 186 to generate an interrupt signal through the interrupt input line 190 to card microprocessor 48. The residual charge flowing in line 190 also has sufficient energy to permit card microprocessor 48 to power down and cease operation in an orderly manner. If this occurs, the VCC power supply

-24-

current through line 184 is also terminated. A battery 192 is provided in this illustrative embodiment to maintain the ticket fare data stored in RAM 58 by means of the memory power lines 194 and 182.

5 In normal operation the VCC current in line 162 provides operating power through the lines 172, 198, and 200 for the comparators 202, 174 and 204. When the power from battery 192 is low, this is sensed by comparator 204 and a signal is fed through a line 206 to card
10 microprocessor 48. Card microprocessor 48 then forwards a digital signal, upon activation, that notifies station computer 96 via target antenna assembly 28 that battery 192 in fare card 12 is low and needs to be replaced. This feature is not necessary for fare card embodiments without
15 batteries.

The signal on line 160 still includes the rectified AM RF carrier data from card antenna 14. This AM voltage is passed through a capacitor 208 to remove the AC modulation and pass it on to comparator 202, which thresholds the AM
20 signal to extract the digital data stream corresponding to the data received. This digital data stream is passed through a line 210 to card microprocessor 48. Card microprocessor 48 then processes and stores this new fare data in the manner previously disclosed.

25 When card microprocessor 48 is instructed to read ticket fare data from RAM 58, the ticket fare data is transferred through a line 211 to an amplifier 212 and therefrom through a line 214 to the Field-Effect Transistor (FET) 216. FET 216 is disposed in parallel with large
30 current-limiting resistor 164. Accordingly, the opening and closing of FET 216 in response to data switches the source impedance in the circuit of card antenna 14, providing the ticket fare data in the form of impedance modulation to the momentary transformer coupling circuit
35 between card antenna 14 and target antenna 34. The

-25-

unrectified RF carrier signal current induced in card antenna 14 is also conducted through a line 218 and the lines 220 and 222 to provide a synchronizing signal to the synchronizer input to card microprocessor 48, appreciated
5 by examining Figure 2.

Referring to Figure 11, a schematic diagram illustrates the operation of our preferred embodiment of fare card circuits 18, requiring neither battery 50 nor battery status sensor 52 shown in Figure 1. Some of the
10 circuits in Figure 11 operate substantially as disclosed in connection with the operation of the circuits in Figure 10 except that the absence of a battery avoids the need for battery check and replacement signal procedures. Card antenna coil 14 and capacitor 152 form a tank circuit
15 resonant at the RF frequency of the magnetic field carrier signal. Diode 156 and capacitor 158 operate as a modulation detector as disclosed above for Figure 10. The detected signal on line 160 is divided by the resistors 224 and 226. Blocking capacitor 208 removes the DC component
20 from the demodulated carrier, comparator 202 decodes the AM RF signal to extract the digital data stream at line 210 and the inverter 228 inverts the digital data stream of 210 and presents it to card microprocessor 48.

When fare card 12 is transmitting data back to target
25 antenna assembly 28, card microprocessor 48 sends a digital data stream on a line 230 to a transistor 232 that operates to vary the source impedance in the tank circuit formed by card antenna 14 and capacitor 152. This is the impedance modulator discussed above and represented in Figure 1 as
30 impedance modulator 60.

The modulated carrier signal on line 162 passes through resistor 164 and a diode 234 to capacitor 170, which filters the AC components leaving a DC VCC power supply voltage at the collector of the series regulator
35 transistor 236. The regulation of the VCC voltage level

-26-

relies on the conduction threshold of zener diode 180, as disclosed for Figure 10, except that the transistors 238 and 240 are provided to more accurately sense and regulate the VCC power supply voltage level.

5 It is important that card microprocessor 48 be aware at all times of the VCC power supply voltage status because an unplanned interruption of VCC can result in loss of ticket fare data or errors arising from partial memory update cycles. Accordingly, a power supply test circuit is
10 provided, comprising an amplifier 242 and a voltage divider formed with the resistors 244 and 246. This test circuit sends a digital signal on a line 248 to enable card microprocessor 48 to power-up when the VCC power supply is sufficient.

15 Once card processor 48 is powered up, an early warning of impending VCC power supply failure is provided on an early warning line 250 to permit an orderly power-down sequence. The early warning signal on line 250 is generated by a D-type flip-flop 252 with the inputs 254 and
20 256. Input 254 is generated by sampling the DC voltage accumulated on capacitor 170 through a voltage divider formed from the resistors 258 and 260. This sample is then compared to the regulated VCC voltage by a comparator 262. The output of comparator 262 will go high and stay high
25 when the voltage accumulated on capacitor 170 stabilizes to the regulated VCC value. Similarly, the same voltage at capacitor 170 is sampled by a voltage divider formed of the three series diodes 264 and the resistor 266. This voltage sample will vary nonlinearly with respect to the current
30 flow from capacitor 170 because of the current-independent voltage drops across diodes 264. The comparator 268 will force line 256 down when the current flow through diodes 264 begins to fall. Accordingly, the output from flip-flop 252 will toggle immediately upon the beginning of a decline

-27-

in the DC current through resistor 266, thereby giving an early warning signal to card microprocessor 48.

5 A clock circuit 270 comprising a crystal and tuning capacitors provides the necessary timing signals for proper operation of card microprocessor 48. An electrically-alterable programmable read-only memory (EAPROM) provides the necessary read and write memory (RAM) 58 functions for this implementation, requiring no battery power to maintain data storage within RAM 58.

10 Obviously, other embodiments and modifications of our invention will occur readily to those of ordinary skill the art in view of these teachings. Therefore, our invention is to be limited only by the following claims, which include all such obvious embodiments and modifications when
15 viewed in conjunction with the above specification and accompanying drawings.

WE CLAIM:

-28-

CLAIMS

1. A non-contact fare card processing system comprising:
 - 2 a transit gate target assembly having a target winding
and a carrier signal means for supplying a continuous RF
4 carrier signal to said target winding;
 - 6 a fare card having a card memory means for storing
ticket fare data and a card winding adapted for making a
8 momentary transformer coupling circuit with said target
winding;
 - 10 magnetically-permeable electrostatic target shielding
means in said transit gate target assembly for blocking
electrostatic coupling to said target winding;
 - 12 magnetically-permeable electrostatic card shielding
means in said fare card for blocking electrostatic coupling
14 to said fare card;
 - 16 card antenna impedance modulator means in said fare
card for modulating the source impedance of said card
winding in response to said ticket fare data, whereby said
18 momentary transformer coupling circuit impedance is
modulated; and
 - 20 target modulation detector means in said transit gate
target assembly, responsive to said impedance modulation of
22 said momentary transformer couplings circuit, for
demodulating said continuous RF carrier signal to obtain
24 said ticket fare data.

-29-

2. The processing system described in Claim 1 further
2 comprising:

target modulator means in said transit gate target
4 assembly for transmitting new fare data to said momentary
transformer coupling circuit by modulating the amplitude of
6 said continuous RF carrier signal.

3. The processing system described in Claim 2 further
2 comprising:

card modulation detector means in said fare card for
4 detecting said continuous RF carrier signal amplitude
modulation in said momentary transformer coupling circuit,
6 for demodulating said continuous RF carrier signal to
obtain said new fare data and for presenting said new fare
8 data to said card processor means.

4. The processing system described in Claim 1 further
2 comprising:

card oscillator means in said fare card for generating
4 a card clock signal synchronized to the frequency of said
continuous RF carrier signal.

5. The processing system described in Claim 4 further
2 comprising:

card synchronizer means in said fare card for
4 synchronizing said impedance modulation of said card
winding to said card clock signal.

-30-

6. The processing system described in Claim 1 further
2 comprising:

power supply rectifier means in said fare card for
4 converting the card carrier current induced by said
momentary transformer coupling circuit into the electrical
6 card power;

first power supply sense means in said fare card for
8 sensing the voltage of said electrical card power and
providing a card activation signal when said voltage
10 reaches a threshold value; and

card reset means in said fare card for energizing said
12 fare card processor from said electrical card power in
response to said card activation signal.

7. The processing system described in Claim 6 in
2 which said card reset means further comprises:

card interrupt means for de-energizing said fare card
4 processor in response to an interruption of said card
activation signal from said first power supply sense means
6 or in response to an interrupt signal from any source.

8. The processing system described in Claim 7 further
2 comprising:

second power supply sense means for sensing a decrease
4 in said electrical card power and for providing said
interrupt signal to said card interrupt means.

9. The processing system described in Claim 1 further
2 comprising:

electrical power supply means in said fare card,
4 responsive to an induced card carrier signal induced by
said continuous RF carrier signal, for rectifying said
6 induced card carrier signal and for providing electrical
card power to said fare card when said induced card carrier
8 signal exceeds a threshold.

-31-

10. The processing system described in Claim 1
2 further comprising:

4 a battery power source in said fare card for
maintaining said ticket fare data stored in said card
memory means.

11. The processing system described in Claim 1
2 wherein:

4 said card processor means comprises means for
providing a first CRC verification signal and means for
encoding said first CRC verification signal as amplitude
6 modulation on said continuous RF carrier signal; and

8 said target modulation detector means comprises target
processor means for calculating and verifying said first
CRC verification signal in response to said ticket fare
10 data demodulated from said continuous RF carrier signal
amplitude.

12. The processing system described in Claim 11
2 wherein:

4 said target processor means comprises means for
providing a second CRC verification signal to said
momentary transformer coupling circuit;

6 said fare card further comprises detector means for
detecting said second CRC verification signal and for
8 transmitting said second CRC verification signal to said
card processor means; and

10 said card processor means further comprises means
responsive to said detected second CRC verification signal
12 and means for calculating and verifying said second CRC
verification signal.

-32-

13. The processing system described in Claim 12
2 wherein:

3 said target processor means further comprises means
4 for providing a CRC verification acknowledgement signal to
5 said card processor means upon successful calculation and
6 verification of said first CRC verification signal; and

7 said card processor means further comprises means for
8 providing said ticket fare data stored in said card memory
9 means to said momentary transformer coupling circuit in
10 response to said CRC verification acknowledgement signal.

14. In a non-contact fare card processing system:
2 a fare card having:

3 a read and write memory for storing ticket fare
4 data,

5 a card antenna winding circuit for making a
6 momentary transformer coupling circuit with a target
7 antenna winding circuit carrying a RF carrier signal, and

8 a magnetically-permeable electrostatic shielding
9 means for blocking electrostatic coupling to said fare
10 card; and

11 card processor means in said fare card for modulating
12 the source impedance of said card antenna winding circuit
13 in response to said stored ticket fare data, thereby
14 transferring said stored ticket fare data to said target
15 winding circuit through said momentary transformer coupling
16 circuit.

-33-

15. In the non-contact fare card processing system
2 described in Claim 14:

4 card synchronizing means in said fare card for
synchronizing said modulating of said source impedance with
said RF carrier signal.

16. In the non-contact fare card processing system
2 described in Claim 15:

4 means in said card processor means for reading said
stored ticket fare data and means for writing new ticket
fare data into said read and write memory.

17. In the non-contact fare card processing system
2 described in Claim 16:

4 means for deriving a CRC verification signal from a
digital data stream received from a source outside said
fare card.

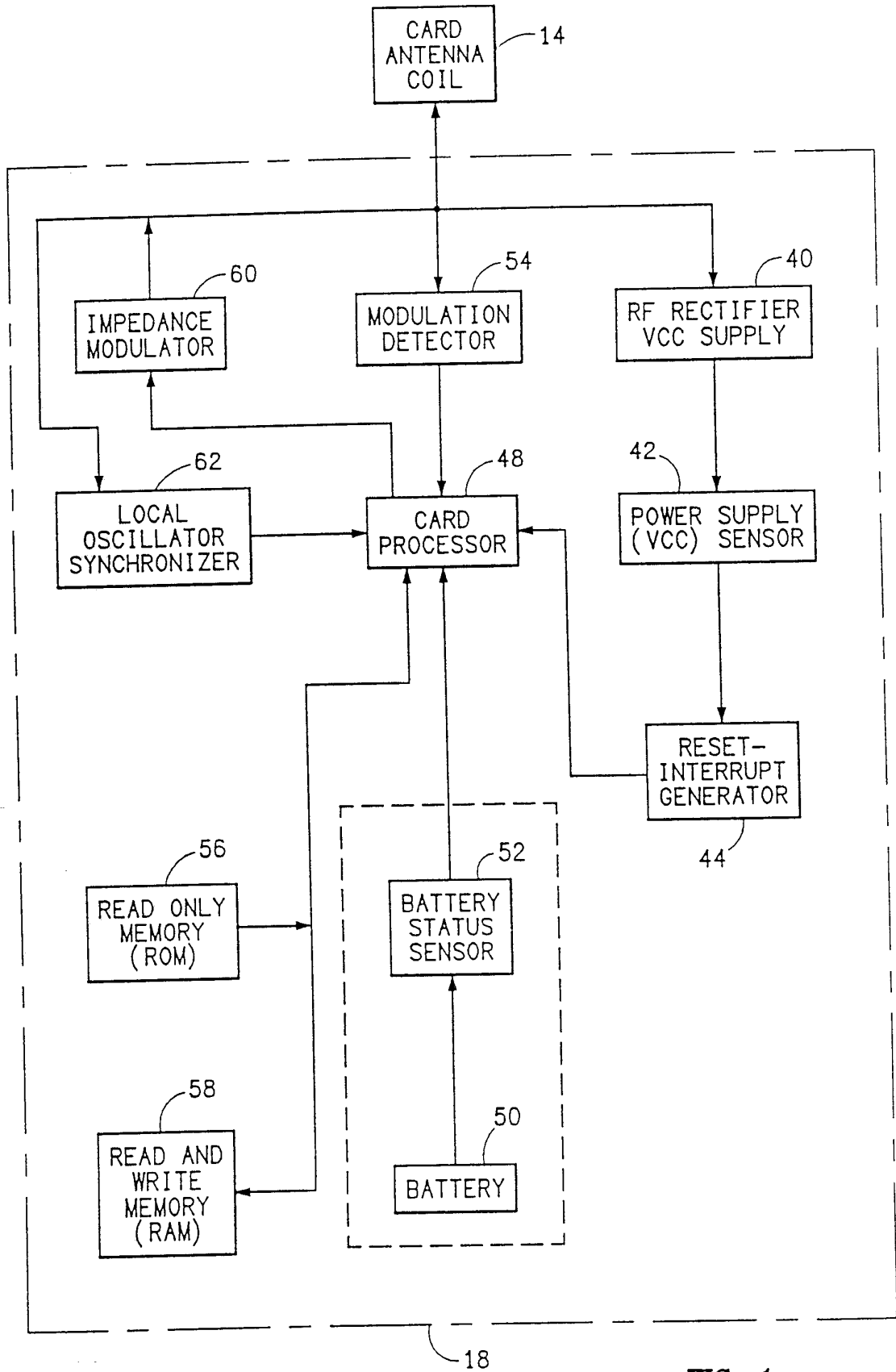
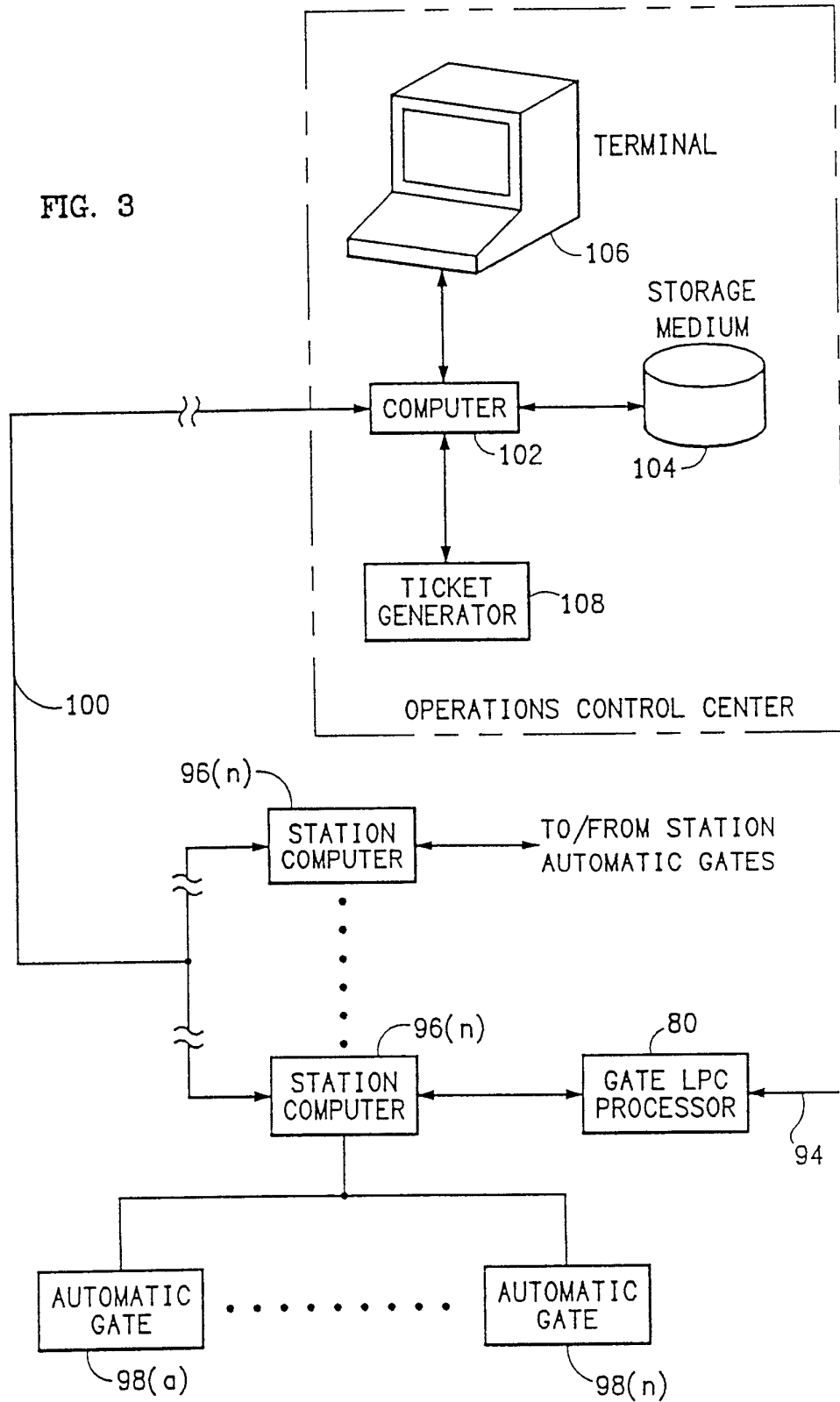

FIG. 1

FIG. 3



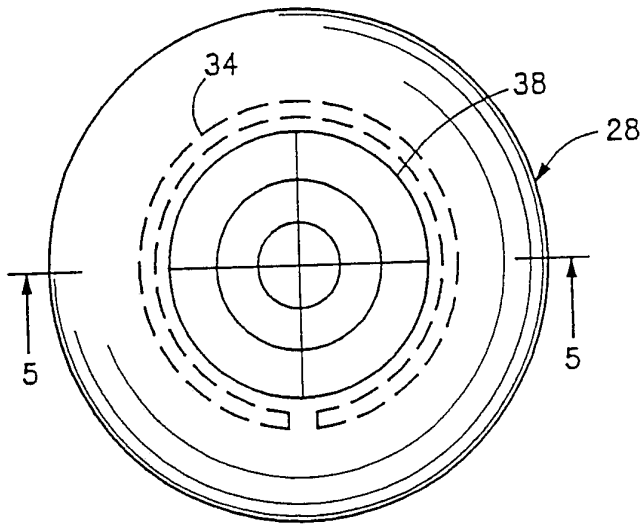

FIG. 4

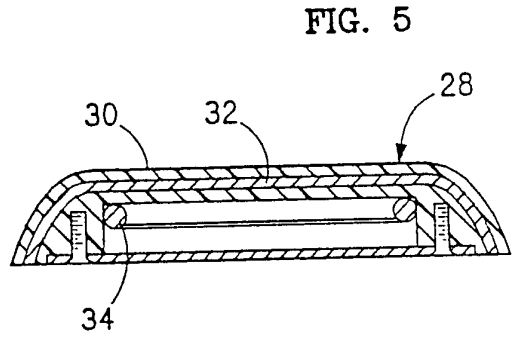

FIG. 5

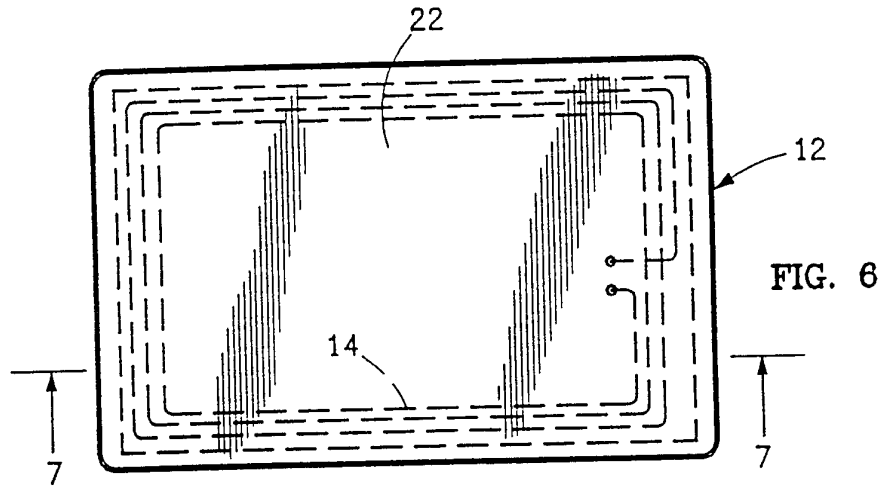

FIG. 6

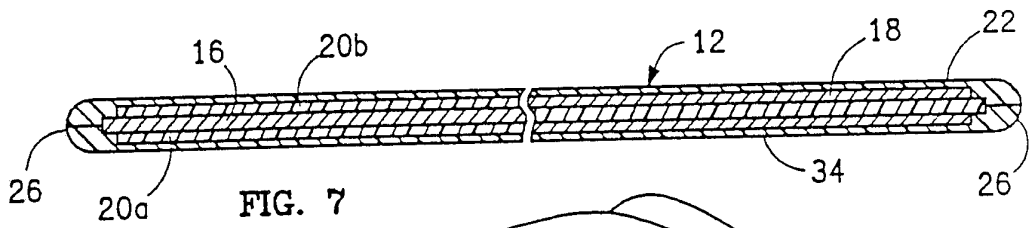

FIG. 7

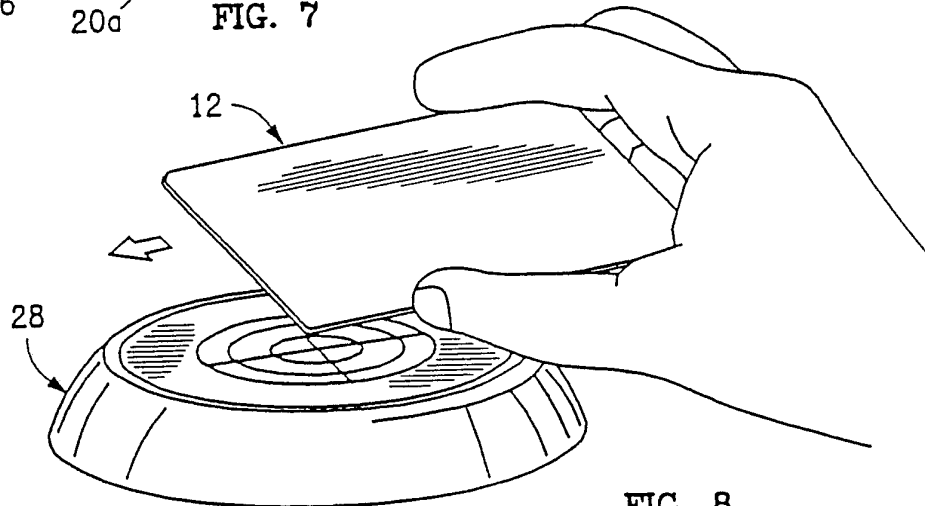

FIG. 8

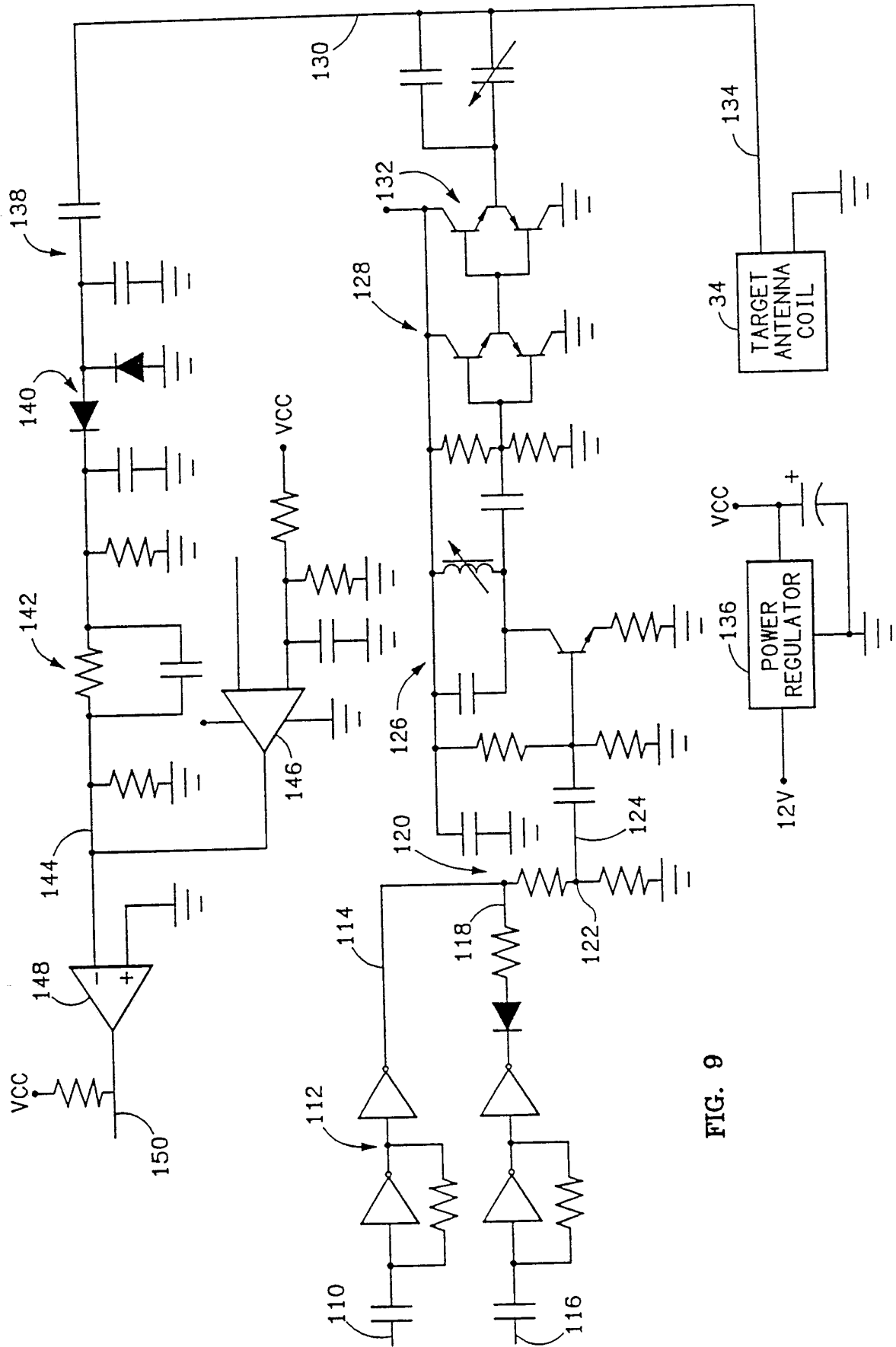

FIG. 9

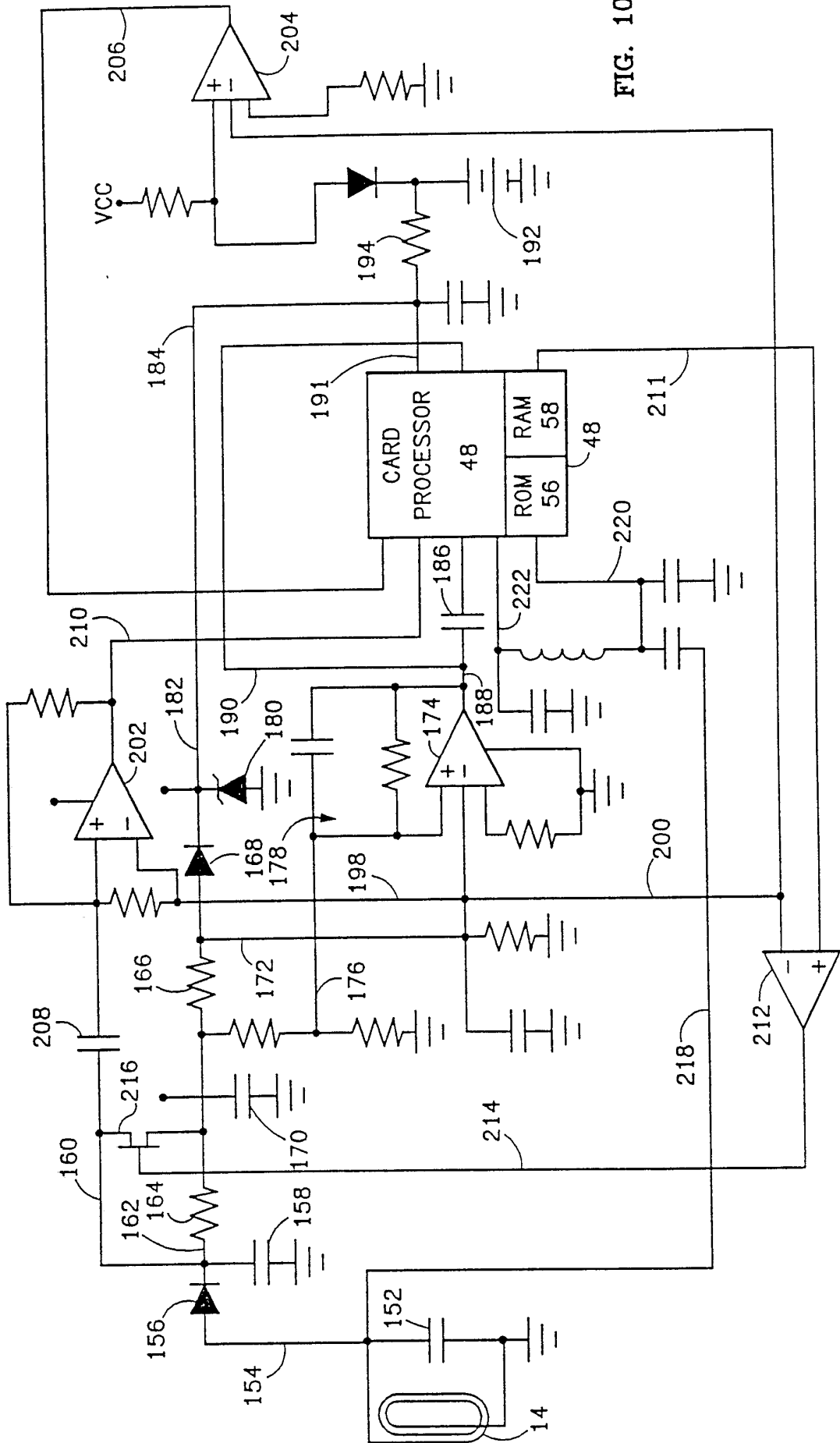

FIG. 10

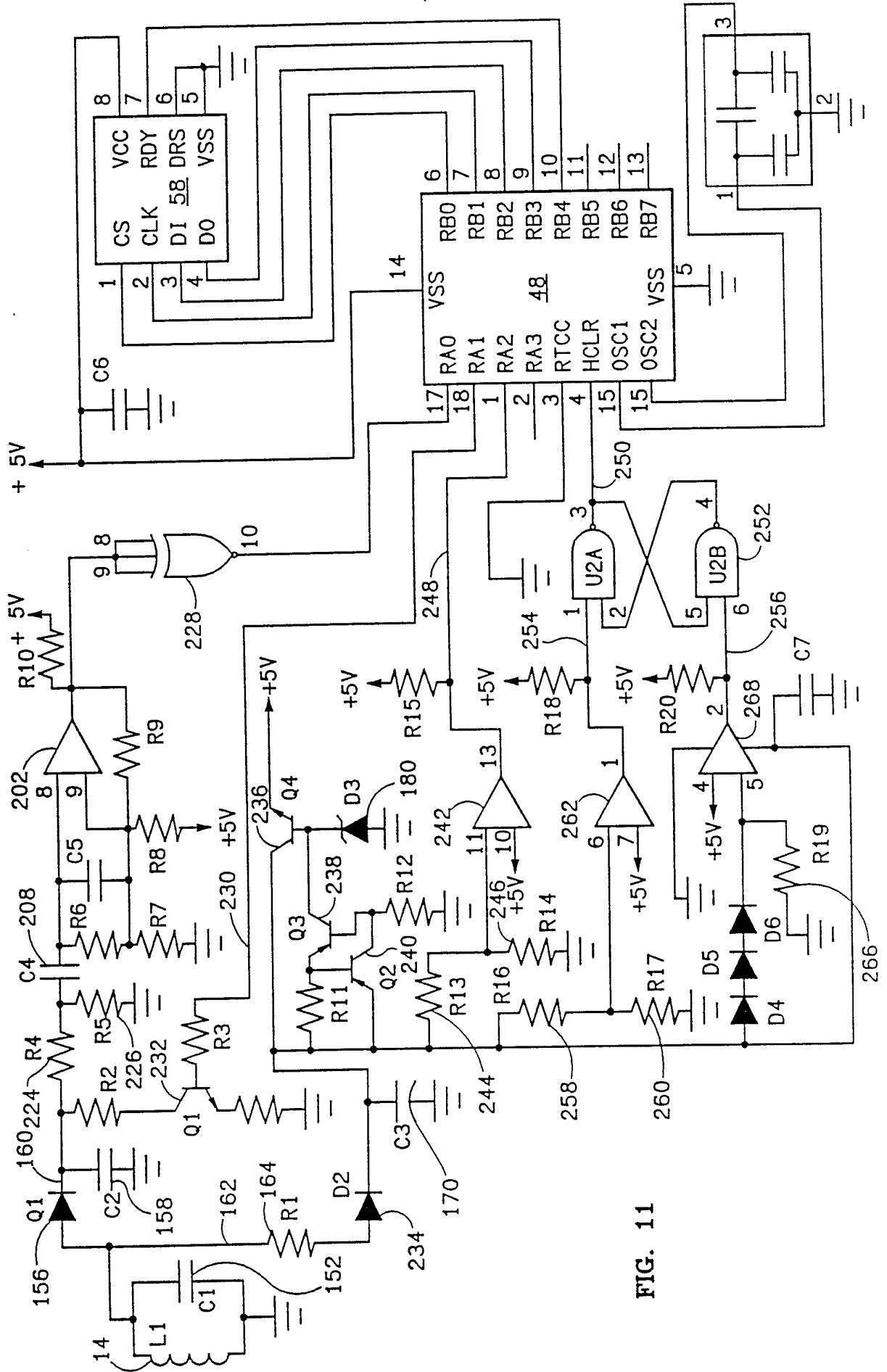

FIG. 11

INTERNATIONAL SEARCH REPORT

International Application No PCT/US 92/08892

I. CLASSIFICATION OF SUBJECT MATTER (if several classification symbols apply, indicate all) ⁶ According to International Patent Classification (IPC) or to both National Classification and IPC IPC5: G 07 B 15/00, G 06 K 7/08, 19/073				
II. FIELDS SEARCHED Minimum Documentation Searched ⁷				
Classification System	Classification Symbols			
IPC5	G 06 K, G 12 B, H 01 Q			
Documentation Searched other than Minimum Documentation to the Extent that such Documents are Included in Fields Searched ⁸				
III. DOCUMENTS CONSIDERED TO BE RELEVANT⁹				
Category *	Citation of Document, ¹¹ with indication, where appropriate, of the relevant passages ¹²	Relevant to Claim No. ¹³		
X	WO, A1, 9114237 (CUBIC WESTERN DATA) 19 September 1991, see the whole document --	1-17		
A	US, A, 4918416 (C.A. WALTON ET AL) 17 April 1990, see abstract; figure 1 -- -----	1-17		
<table style="width: 100%; border: none;"> <tr> <td style="width: 50%; border: none; vertical-align: top;"> <p>* Special categories of cited documents:¹⁰</p> <p>"A" document defining the general state of the art which is not considered to be of particular relevance</p> <p>"E" earlier document but published on or after the international filing date</p> <p>"L" document which may throw doubts on priority claim(s) or which is cited to establish the publication date of another citation or other special reason (as specified)</p> <p>"O" document referring to an oral disclosure, use, exhibition or other means</p> <p>"P" document published prior to the international filing date but later than the priority date claimed</p> </td> <td style="width: 50%; border: none; vertical-align: top;"> <p>"T" later document published after the international filing date or priority date and not in conflict with the application but cited to understand the principle or theory underlying the invention</p> <p>"X" document of particular relevance, the claimed invention cannot be considered novel or cannot be considered to involve an inventive step</p> <p>"Y" document of particular relevance, the claimed invention cannot be considered to involve an inventive step when the document is combined with one or more other such documents, such combination being obvious to a person skilled in the art.</p> <p>"&" document member of the same patent family</p> </td> </tr> </table>			<p>* Special categories of cited documents:¹⁰</p> <p>"A" document defining the general state of the art which is not considered to be of particular relevance</p> <p>"E" earlier document but published on or after the international filing date</p> <p>"L" document which may throw doubts on priority claim(s) or which is cited to establish the publication date of another citation or other special reason (as specified)</p> <p>"O" document referring to an oral disclosure, use, exhibition or other means</p> <p>"P" document published prior to the international filing date but later than the priority date claimed</p>	<p>"T" later document published after the international filing date or priority date and not in conflict with the application but cited to understand the principle or theory underlying the invention</p> <p>"X" document of particular relevance, the claimed invention cannot be considered novel or cannot be considered to involve an inventive step</p> <p>"Y" document of particular relevance, the claimed invention cannot be considered to involve an inventive step when the document is combined with one or more other such documents, such combination being obvious to a person skilled in the art.</p> <p>"&" document member of the same patent family</p>
<p>* Special categories of cited documents:¹⁰</p> <p>"A" document defining the general state of the art which is not considered to be of particular relevance</p> <p>"E" earlier document but published on or after the international filing date</p> <p>"L" document which may throw doubts on priority claim(s) or which is cited to establish the publication date of another citation or other special reason (as specified)</p> <p>"O" document referring to an oral disclosure, use, exhibition or other means</p> <p>"P" document published prior to the international filing date but later than the priority date claimed</p>	<p>"T" later document published after the international filing date or priority date and not in conflict with the application but cited to understand the principle or theory underlying the invention</p> <p>"X" document of particular relevance, the claimed invention cannot be considered novel or cannot be considered to involve an inventive step</p> <p>"Y" document of particular relevance, the claimed invention cannot be considered to involve an inventive step when the document is combined with one or more other such documents, such combination being obvious to a person skilled in the art.</p> <p>"&" document member of the same patent family</p>			
IV. CERTIFICATION				
Date of the Actual Completion of the International Search	Date of Mailing of this International Search Report			
11th January 1993	02 FEB 1993			
International Searching Authority	Signature of Authorized Officer			
EUROPEAN PATENT OFFICE	ROLAND LANDSTRÖM			

ANNEX TO THE INTERNATIONAL SEARCH REPORT
ON INTERNATIONAL PATENT APPLICATION NO. PCT/US 92/08892

SA 66037

This annex lists the patent family members relating to the patent documents cited in the above-mentioned international search report.
The members are as contained in the European Patent Office EDP file on 02/12/92
The European Patent office is in no way liable for these particulars which are merely given for the purpose of information.

Patent document cited in search report	Publication date	Patent family member(s)	Publication date
WO-A1- 9114237	19/09/91	AU-D- 7483791	10/10/91
US-A- 4918416	17/04/90	NONE	

For more details about this annex : see Official Journal of the European patent Office, No. 12/82