

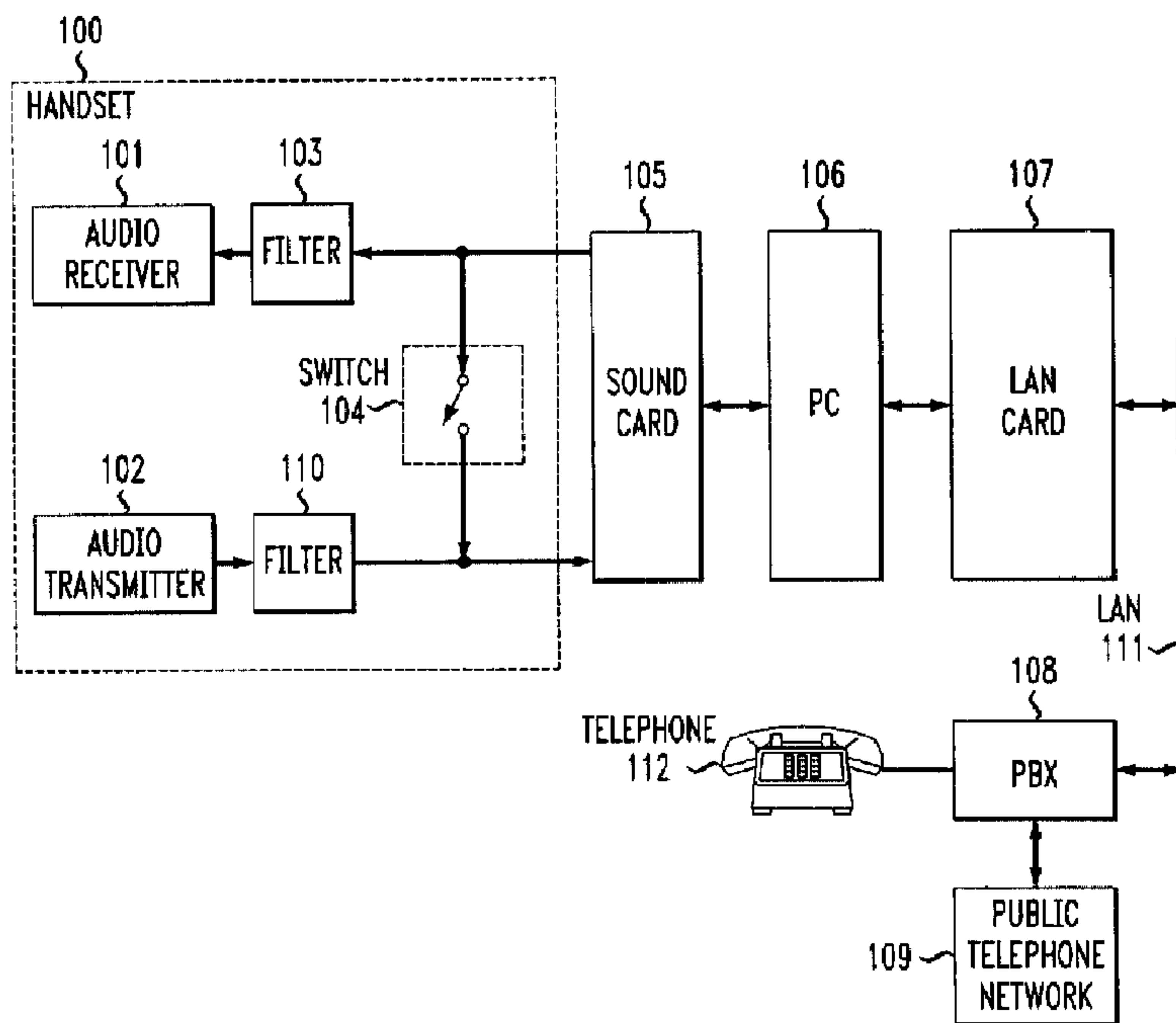

(22) Date de dépôt/Filing Date: 2001/05/01
 (41) Mise à la disp. pub./Open to Public Insp.: 2002/01/31
 (45) Date de délivrance/Issue Date: 2004/10/19
 (30) Priorité/Priority: 2000/07/31 (09/628,481) US

(51) Cl.Int.⁷/Int.Cl.⁷ H04M 11/06, H04L 12/66
 (72) Inventeur/Inventor:
 BECKER, GARY, US
 (73) Propriétaire/Owner:
 AVAYA TECHNOLOGY CORP., US
 (74) Agent: KIRBY EADES GALE BAKER

(54) Titre : DETECTION PASSIVE DES REPONSES POUR TELEPHONES DE TYPE IP
 (54) Title: ANSWER DETECTION FOR IP BASED TELEPHONES USING PASSIVE DETECTION



(57) Abrégé/Abstract:

Deactivating a switch in a handset when a user wishes to answer an incoming call or terminate a call. A sound card within a personal computer transmits a hook tone that is above the human hearing range to a transmitter section of the handset. When the switch is in the activated state, the handset re-transmits the hook tone back to the sound card which converts the hook tone to digital information so that the hook tone can be detected by software running in the personal computer. When the manual switch is deactivated, the handset ceases to re-transmit the hook tone back to the sound card. The software detects the absence of the hook tone to determine if the handset is answering the incoming call. In traditional telephony terms, when the manual switch is deactivated, this is the offhook condition. When the manual switch is activated, this is the onhook condition. When the user is finished with the call and activates the manual switch, the handset again starts re-transmitting hook tone that causes the hook tone to be detected by the software via the sound card. Then, the software signals the other party on the call that the call has been terminated. Low-pass filters are utilized in the handset to block the hook tone from the receiver and transmitter sections of the handset. A headset is similarly designed to provide the same switching features as the handset.

ANSWER DETECTION FOR IP BASED TELEPHONES USING PASSIVE DETECTION

Abstract

Deactivating a switch in a handset when a user wishes to
5 answer an incoming call or terminate a call. A sound card within a
personal computer transmits a hook tone that is above the human hearing
range to a transmitter section of the handset. When the switch is in the
activated state, the handset re-transmits the hook tone back to the sound
card which converts the hook tone to digital information so that the hook
10 tone can be detected by software running in the personal computer.
When the manual switch is deactivated, the handset ceases to re-transmit
the hook tone back to the sound card. The software detects the absence
of the hook tone to determine if the handset is answering the incoming
call. In traditional telephony terms, when the manual switch is
15 deactivated, this is the offhook condition. When the manual switch is
activated, this is the onhook condition. When the user is finished with the
call and activates the manual switch, the handset again starts re-
transmitting hook tone that causes the hook tone to be detected by the
software via the sound card. Then, the software signals the other party on
20 the call that the call has been terminated. Low-pass filters are utilized in
the handset to block the hook tone from the receiver and transmitter
sections of the handset. A headset is similarly designed to provide the
same switching features as the handset.

ANSWER DETECTION FOR IP BASED TELEPHONES USING PASSIVE DETECTION

Technical Field

This invention relates to telephones in general, and in particular
5 two or more telephones communicating using an IP protocol.

Background of the Invention

An IP softphone consists of a software package running on a
personal computer (PC). The software emulates a telephone and
communicates signaling and voice information via a IP-network
10 connection between the PC and a telecommunication switching system
(also referred to as a PBX). This network connection is often the Internet
or a LAN. Audio information being received from the network is
communicated with the user via a headset or handset via a sound card
that interfaces the headset or handset to the PC. When a user speaks,
15 the sound card converts the analog information into digital information that
the software then transmits to a destination via the network. When a call
is received via the network for the IP softphone, the software alerts the
user via a speaker attached to the PC. The user then answers the call by
selecting the softphone software application and selecting a soft button
20 labeled "answer". The user then conducts a conversation with the caller
via either the handset or the headset. To place a call, the user once again
selects the software and selects a soft button labeled "Number" and
proceeds to dial the destination number using a keypad or a pre-stored list
of telephone numbers. The keypad can be either a soft keypad or the
25 PC's keyboard.

A common problem is that while a user is walking into their
office, they then hear the IP softphone ringing. To answer the call, the
user must unlock the screen blanker to access the PC, select the software
application, and actuate the soft button labeled "answer". Then, the user
30 can pick up the handset or the headset and talk. The problem is that a

great amount of time is involved in performing these steps. Frequently, before the user has completed the steps, the call is transferred to coverage such as a voice mail system.

An apparently obvious solution would be to have a switch in the
5 handset that was activated when the handset was picked up to answer the call. However, the vast majority of sound cards do not have a physical input that can sense a switch. One solution that has been utilized is in the Microsoft Netmeeting application. Microsoft Netmeeting attempts to solve this problem by having an option referred to as "call, automatically accept
10 calls". Utilizing this option, a user need only start listening and talking in order to participate in the call. The disadvantage of this option is that a call is always answered whether or not the user is available or not. This leads to a great deal of frustration for callers if the user is not there. Further, at times, the called party may simply not want to answer the call
15 at a particular time.

Summary of the Invention

This invention is directed to solving these and other problems and disadvantages of the prior art. According to the invention, a handset has a switch that is manually deactivated when the user wishes to answer
20 an incoming call, or manually activated when the user wishes to terminate a call. A sound card within a personal computer transmits a hook tone that is above the human hearing range to a transmitter section of the handset. When the switch is in the activated state, the handset re-transmits the hook tone back to the sound card which converts the hook
25 tone to digital information so that the hook tone can be detected by software running in the personal computer. When the manual switch is deactivated, the handset ceases to re-transmit the hook tone back to the sound card. The software detects the absence of the hook tone to determine if the handset is answering the incoming call. In traditional
30 telephony terms, when the manual switch is deactivated, this is the

offhook condition. When the manual switch is activated, this is the onhook condition. When the user is finished with the call and activates the manual switch, the handset again starts re-transmitting hook tone that causes the hook tone to be detected by the software via the sound card. Then, the software signals the other party on the call that the call has been terminated. Advantageously, low-pass filters are utilized in the handset to block the hook tone from the receiver and transmitter sections of the handset. A headset is similarly designed to provide the same switching features as the handset.

10 In accordance with one aspect of the present invention there is provided a method for determining call answer by an IP softphone that includes software executing on a personal computer and a handset having an audio receiver connected to an input conductor and an audio transmitter connected to an output conductor, comprising
15 the steps of: interconnecting the handset to a telecommunication switching system via the personal computer; receiving an incoming call from the telecommunication switching system by the personal computer; generating a hook tone whose frequency is outside of a range of human hearing by the personal computer using a sound card;
20 transmitting the generated hook tone to the handset by the sound card via the input connector of the handset; re-transmitting the generated hook tone back to the personal computer by a switch in the handset by connecting the input conductor from the sound card to the output conductor to the sound card upon the handset being in an idle state;
25 blocking the generated hook tone from being re-transmitted back to the personal computer by the switch in the handset by disconnecting the input conductor from the sound card to the output conductor to the sound card upon the handset being in an active state; blocking the transmission of the hook tone to the audio receiver and the audio
30 transmitter by low-pass filters in the handset; connecting the incoming call to the IP softphone by the personal computer upon no hook tone

3a

being re-transmitted back from the handset; and communicating audio information between the handset and the telecommunication switching system by the personal computer after connection of the incoming call.

In accordance with another aspect of the present

5 invention there is provided an apparatus for determining call answer by an IP softphone that includes software executing on a personal computer and a handset having an audio receiver connected to an input conductor and an audio transmitter connected to an output conductor, comprising the steps of: the handset interconnecting to a

10 telecommunication switching system via the personal computer; the personal computer receiving an incoming call from the telecommunication switching system; personal computer using a sound card generating a hook tone whose frequency is outside of a range of human hearing; the sound card transmitting the generated hook tone to

15 the handset via the input connector of the handset; a switch in the handset re-transmitting the generated hook tone back to the personal computer by connecting the input conductor from the sound card to the output conductor to the sound card upon the handset being in an idle state; the switch in the handset blocking the generated hook tone from

20 being re-transmitted back to the personal computer disconnecting the input conductor from the sound card to the output conductor to the sound card upon the handset being in an active state; blocking the transmission of the hook tone to the audio receiver and the audio transmitter by low-pass filters in the handset; the personal computer

25 connecting the incoming call to the IP softphone upon no hook tone being re-transmitted back from the handset; and the personal computer communicating audio information between the handset and the telecommunication switching system after connection of the incoming call.

3b

These and other advantages and features of the present invention will become apparent from the following description of an illustrative embodiment of the invention taken together with the drawings.

5 **Brief Description of the Drawings**

FIG. 1 illustrates, in block diagram form, a system for utilizing the present invention;

FIG. 2 illustrates, in block diagram form, a software structure for utilizing the present invention; and

10 FIGS. 3 and 4 illustrate, in flowchart form, the steps performed by software applications.

Detailed Description

FIG. 1 illustrates the system for implementing the invention. In FIG. 1, PBX 108 is supplying telephone service for a user that is utilizing handset 100 via sound card 105, personal computer (PC) 106, LAN card 107 and LAN 111. PBX 108 supplies access to the general public by being interconnected to public telephone network 109. One skilled in the art would readily see that LAN card 107 and sound card 105 could be internal to PC 106. PBX 108 can advantageously be a Lucent Definity® Business Communication Switching System. PBX 108 supplies service for other users utilizing conventional telephones such as telephone 112. In addition, other handsets similar to handset 100 can be interconnected

to LAN 111 by having individual sound cards, PCs and LAN cards. PC 106 receives control signaling and voice information from PBX 108, and PC 106 in turn transmits voice information and control signaling information to PBX 108 via LAN card 107 and LAN 111. Sound card 105
5 performs the function of converting audio information received from PC 106 to analog signals and transmitting these to audio receiver 101 that advantageously can be a simple speaker arranged in handset 100. Sound card 105 similarly converts audio information received from audio
10 transmitter 102 (that advantageously can be a simple microphone) to digital information which is transmitted to PC 106. In addition, sound card 105 also generates a hook tone that is above the human hearing range for transmission to handset 100. Also, sound card 105 provides the facilities for converting this hook tone into digital information for detection by software after the hook tone is received back from handset 100.
15 Software applications in PC 106 emulate a telephone such as telephone 112 with respect to PBX 108 with the exception that PBX 108 is transmitting and receiving information via LAN 111 rather than a telephone link. Sound card 105, PC 106, and LAN card 107 are of a conventional design well-known to those skilled in the art.

20 When not in use, handset 100 sets in a physical apparatus that actuates switch 104 so that the hook tone being received from sound card 105 is re-transmitted back to sound card 105. When a user picks up and places handset 100 to the user's ear, removal from the physical apparatus causes switch 104 to be deactuated so that the hook tone
25 received from sound card 105 is not re-transmitted back to sound card 105. Low-pass filter 103 prevents the hook tone from being transmitted to audio receiver 100, and low-pass filter 110 prevents the hook tone from being transmitted to audio transmitter 102. Low-pass filters 103 and 110 are low-pass passive filters that block the hook tone
30 but communicate audio information in human hearing range. Such filters are well known to those skilled in the art.

Consider the following example. If telephone 112 places a call to handset 100, PBX 108 transmits control signaling information to PC 106. PC 106 then provides an audio alerting sound via an internal speaker of PC 106 or other apparatus well-known to those skilled in the art. In addition, PC 106 transmits control information to sound card 105 that causes sound card 105 to start generation of the hook tone for transmission to handset 100 and to start converting the re-transmitted hook tone from handset 100 to digital information. Software in PC 106 (audio client 202 of FIG. 2) monitors for the hook tone (as digital information) from handset 100 received via sound card 105. When the user of handset 100 deactivates switch 104 by removing handset 100 from the physical apparatus, switch 104 now ceases to re-transmit the hook tone back to sound card 105. When the software detects the absence of the hook tone from handset 100, PC 106 transmits control information back to PBX 108 indicating that the call has been answered by handset 100. The telephone conversation then takes place in a normal manner by the user of handset 100 hearing speech from the user of telephone 112 via audio receiver 100 and speaking to the user of telephone 112 via audio transmitter 102. When the user of handset 100 ends the conversation by placing handset 100 on the physical apparatus, switch 104 is activated to re-transmit the hook tone back to sound card 105. During the telephone call, software in PC 106 (audio client 202 of FIG. 2) continues to monitor for the hook tone after the hook tone has been converted to digital information by sound card 105. When this hook tone is detected again, this fact is transmitted as control information to PBX 108 by PC 106 indicating that the call has been disconnected, and PBX 108 responds in a normal manner. In addition, PC 106 transmits control information to sound card 105 that causes sound card 105 to cease generation of the hook tone for transmission to handset 100.

FIG. 2 illustrates, in block diagram form, the structure of the software within PC 106 utilized to provide the functions for handset 100.

The messages transmitted among the software elements 201-204 are conveyed via a standard operating system not illustrated in FIG. 2. Drivers 201 and 203 provide the standard software interface to sound card 105 and LAN card 107, respectively. Such drivers are well-known to those skilled in the art. Softphone application 204 provides the overall control not only of the communication of calls with PBX 108 but also control over the functions of audio client 202. When the control information is received from PBX 108 indicating that there is an incoming call, this information is relayed from LAN card driver 203 to softphone application 204. Softphone application 204 then signals the operating system to produce a ringing sound on the internal speaker of PC 106 and starts sound card 201 generating and transmitting the hook tone to handset 100. In addition, softphone application 204 requests that sound card driver 201 start converting audio information from handset 100 to digital information and that audio client 202 start the detection for the absence of the hook tone from handset 100. When audio client 202 detects that the hook tone is no longer being received from sound card 105, it transmits control information to softphone application 204 indicating this fact. Softphone application 204 is responsive to the absence of the hook tone to transmit a control message to PBX 108 via LAN card driver 203 indicating that the call has been answered. Softphone application 204 then interacts with PBX 108 to exchange the necessary control information so that the call can be completed. Softphone application 204 controls audio client 202 so that audio client 202 is responsive to digital samples received from LAN card driver 203 to relay these to sound card driver 201 and to relay digital samples received from sound card driver 201 to LAN card driver 203. When the re-transmitted hook tone from handset 100 via sound card 105 is again detected by audio client 202, it signals this fact to softphone application 204. In response, softphone application 204 transmits a disconnect message to PBX 108 to cause the call to be terminated. If the

user of telephone 112 hangs up on the call first, PBX 108 sends a disconnect message to softphone application 204 that resets the call state of the soft phone with respect to the software elements 201-204. In addition, softphone application 204 transmits control information to audio client 202 that causes audio client 202 to cease sending the digital information to sound card driver 201 to generate the hook tone.

FIGS. 3 and 4 illustrate, in flow chart form, the steps performed by softphone application 204. Upon being started, decision block 301 checks to see if an incoming call is being received from PBX 108. If the answer is yes, control is transferred to block 401 that transmits an alerting message to PBX 108 indicating that the called telephone is being alerted. In addition, block 401 alerts the user by the transmission of control information to sound card driver 201 to start the alerting utilizing the internal speaker of PC 106. Next, block 402 starts sound card 105 generating the hook tone and starts audio client 202 detecting for the re-transmitted hook tone received via sound card 105. Decision block 403 determines when softphone application 204 receives a message from audio client 202 indicating that the hook tone is no longer being detected. Once this message is received, decision block 403 transfers control to block 404 that transmits an answer message to PBX 108.

Block 404 then transfers control to decision block 406 which determines if a connect message is received from PBX 108. The connect message indicates that the call is fully set up between the calling telephone and the called telephone by PBX 108. If the connect message is not received, control is transferred to block 407 that performs the normal processing required to return the state of the software elements illustrated in FIG. 2 to the no active call state. If a connect message is detected, decision block 406 transfers control to block 408. The latter block sets the state of softphone application 204 to the active call state before transferring control to block 409. Block 409 initiates the transfer of digital

samples by audio client 202 before transferring control back to decision block 301 of FIG. 3.

If the answer in decision block 301 is no, decision block 302 determines if a call origination is being performed by the user of handset 100. A call origination is done by the user interacting with softphone application 204 utilizing a GUI interface. If the answer is yes in decision block 302, control is transferred to block 311 which transmits a setup message to PBX 108 indicating that handset 100 is initiating a call. The setup message includes the telephone number of the called telephone. Next, block 312 starts sound card 105 generating the hook tone and starts audio client 202 watching for the re-transmitted hook tone received via sound card 105 from handset 100 so as to determine when the user of handset 100 has terminated the call. Block 313 initiates the transfer of digital samples by audio client 202 before transferring control to decision block 411 of FIG. 4. Decision block 411 determines when a connect message is received from PBX 108 indicating that the call has been established. If a connect message is detected, control is transferred to block 412 which sets the state of softphone application 204 to the active call state before transferring control back to decision block 301 of FIG. 1. If the answer in decision block 411 is no, control is transferred to block 413 that does the necessary operations to return all software elements of FIG. 2 to the no active call state before transferring control back to decision block 301.

Returning to decision block 302, if the answer in decision block 302 is no, control is transferred to decision block 303 that determines if a call disconnect has been made by handset 100 or by the far end party hanging up. If the answer is no, control is transferred to block 304 that performs normal processing before returning control back to decision block 301. If the answer in decision block 303 is yes, control is transferred to block 306 that stops the transfer of digital samples by audio client 202. Next, block 307 transmits a disconnect message to PBX 108

to terminate the call. Then, block 308 stops the generation of the hook tone by sound card 105 and stops the watching for the hook tone by audio client 202 via sound card 105. (Block 307 also determines if a disconnect message is received from PBX 108; and if so, block 307 transmits an
5 acknowledgement message to PBX 108.) Finally, block 309 re-sets the internal status of all of the software elements of FIG. 2 to the no call active state before transferring control back to decision block 301.

Claims:

1. A method for determining call answer by an IP softphone that includes software executing on a personal computer and a handset having an audio receiver connected to an input conductor and an audio transmitter connected to an output conductor, comprising the steps of:
- 5 interconnecting the handset to a telecommunication switching system via the personal computer;
- receiving an incoming call from the telecommunication switching system by the personal computer;
- 10 generating a hook tone whose frequency is outside of a range of human hearing by the personal computer using a sound card;
- transmitting the generated hook tone to the handset by the sound card via the input connector of the handset;
- re-transmitting the generated hook tone back to the personal computer by a switch in the handset by connecting the input conductor from the sound card to the output conductor to the sound card upon the handset being in an idle state;
- 15 blocking the generated hook tone from being re-transmitted back to the personal computer by the switch in the handset by disconnecting the input conductor from the sound card to the output conductor to the sound card upon the handset being in an active state;
- 20 blocking the transmission of the hook tone to the audio receiver and the audio transmitter by low-pass filters in the handset;
- connecting the incoming call to the IP softphone by the personal computer upon no hook tone being re-transmitted back from the handset;
- 25 and
- communicating audio information between the handset and the telecommunication switching system by the personal computer after connection of the incoming call.
- 30
2. The method of claim 1 wherein the software comprises an audio

client application and a softphone application, and the step of receiving the incoming call comprises the step of accepting a setup message from the telecommunication switching system by the softphone application.

- 5 **3.** An apparatus for determining call answer by an IP softphone that includes software executing on a personal computer and a handset having an audio receiver connected to an input conductor and an audio transmitter connected to an output conductor, comprising the steps of:
- 10 the handset interconnecting to a telecommunication switching system via the personal computer;
- the personal computer receiving an incoming call from the telecommunication switching system;
- personal computer using a sound card generating a hook tone whose frequency is outside of a range of human hearing;
- 15 the sound card transmitting the generated hook tone to the handset via the input connector of the handset;
- a switch in the handset re-transmitting the generated hook tone back to the personal computer by connecting the input conductor from the sound card to the output conductor to the sound card upon the handset
- 20 being in an idle state;
- the switch in the handset blocking the generated hook tone from being re-transmitted back to the personal computer disconnecting the input conductor from the sound card to the output conductor to the sound card upon the handset being in an active state;
- 25 blocking the transmission of the hook tone to the audio receiver and the audio transmitter by low-pass filters in the handset;
- the personal computer connecting the incoming call to the IP softphone upon no hook tone being re-transmitted back from the handset; and
- 30 the personal computer communicating audio information between the handset and the telecommunication switching system after connection

of the incoming call.

4. The apparatus of claim 3 wherein the software comprises an audio client application and a softphone application, and the step of
5 receiving the incoming call comprises the step of accepting a setup message from the telecommunication switching system by the softphone application.

FIG. 1

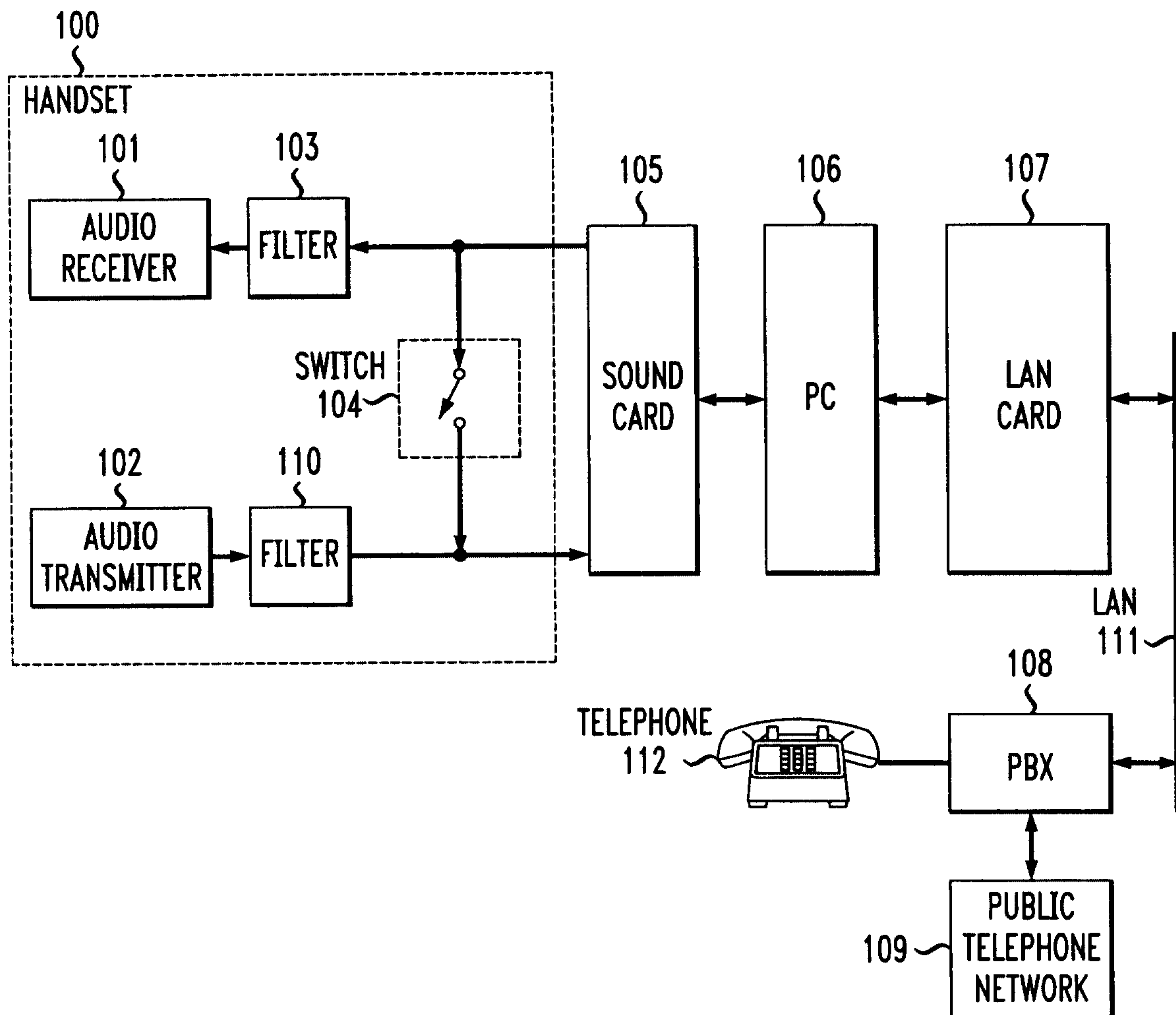

FIG. 2

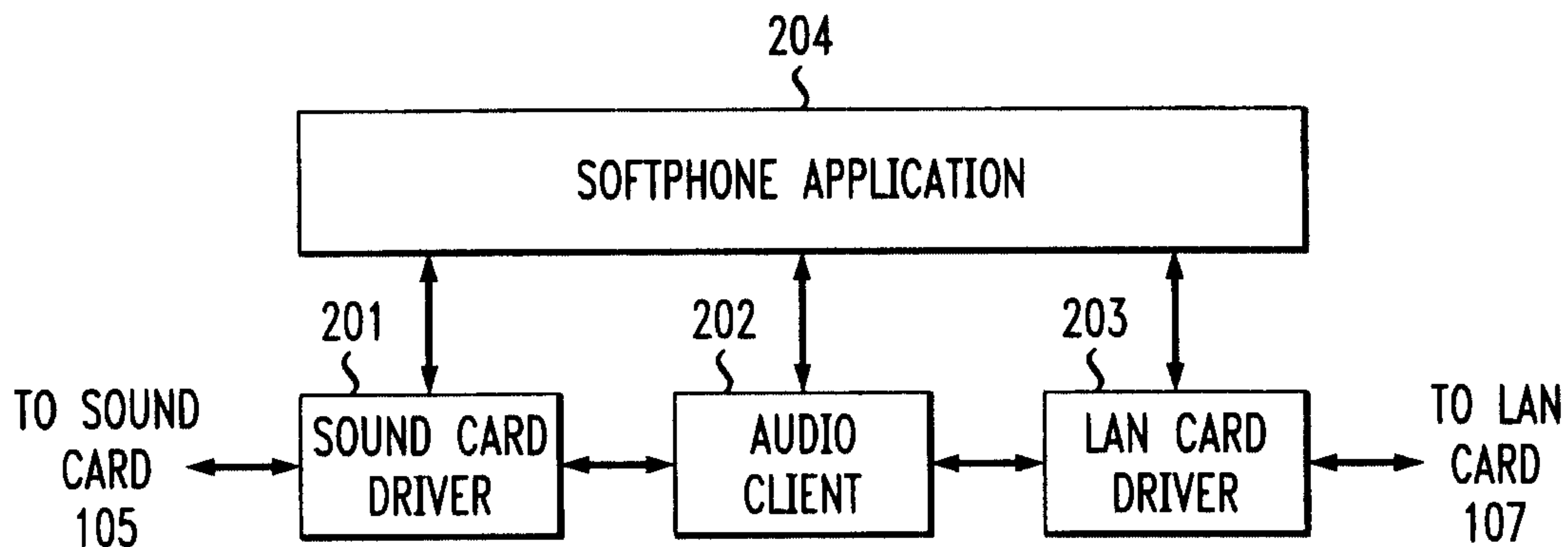
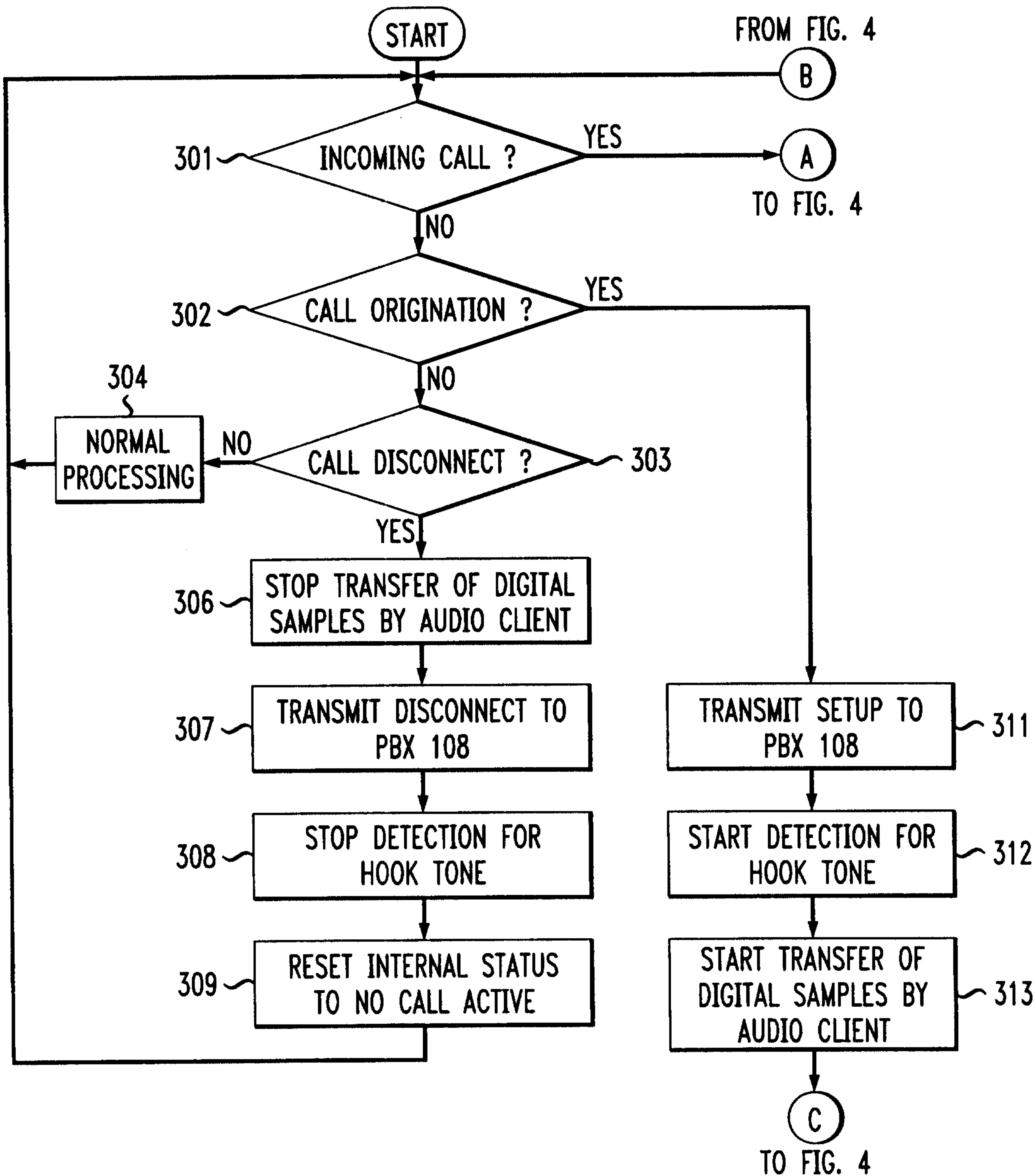

FIG. 3



3/3

FIG. 4

FROM FIG. 3

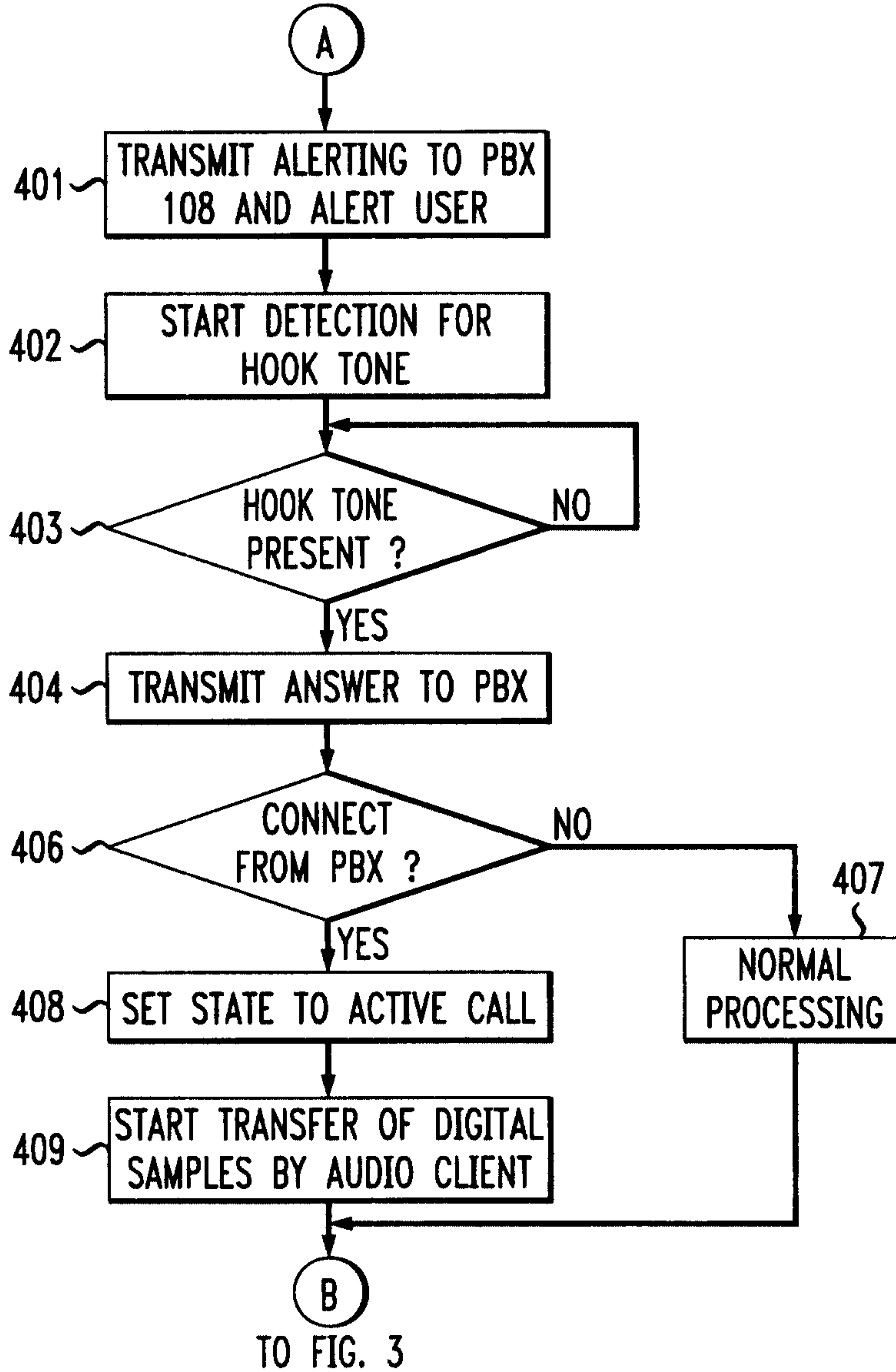

FROM FIG. 3

