



US00D900480S

(12) **United States Design Patent**  
**Mink**

(10) **Patent No.:** **US D900,480 S**

(45) **Date of Patent:** **\*\* Nov. 3, 2020**

(54) **ANGLED CHISEL BRUSH**  
(71) Applicant: **FM Brush Co., Inc.**, Glendale, NY (US)

2,244,098 A 6/1941 Busick  
2,819,482 A 1/1958 Applegate  
3,964,122 A 6/1976 Kurdy  
4,088,413 A 5/1978 Rossignol de la Ronde et al.  
(Continued)

(72) Inventor: **Jeffrey Mink**, Glen Head, NY (US)  
(73) Assignee: **FM BRUSH CO., INC.**, Glendale, NY (US)  
(\*\*) Term: **15 Years**

**FOREIGN PATENT DOCUMENTS**

DE 2402322 10/1974  
JP 2004041306 2/2004  
JP 1309937 9/2007

(21) Appl. No.: **29/677,411**  
(22) Filed: **Jan. 20, 2019**

**OTHER PUBLICATIONS**

Chisel Shaper, announced 2020 [online], [site visited Jun. 2, 2020]. Available from internet, URL: <https://www.walmart.com/ip/Armadillo-Colour-Shaper-Firm-Angle-Chisels-16/23918127?wmlspartner=wlpa&selectedSellerId=1131> (Year: 2020).\*

**Related U.S. Application Data**  
(60) Provisional application No. 62/713,456, filed on Aug. 1, 2018.  
(51) **LOC (12) CL.** ..... **04-99**  
(52) **U.S. Cl.**  
USPC ..... **D4/127**  
(58) **Field of Classification Search**  
USPC ..... D4/100, 102, 106, 107, 109, 110, 111, D4/112, 117, 120, 126, 127, 128, 129, D4/130, 131, 132, 133, 134, 135, 136, D4/137, 138; D28/7, 13, 19, 21, 22, 23, D28/24, 28, 29, 30, 31, 32, 33, 45, 63, D28/74; D30/158, 159; D7/682; D8/107, 303  
CPC ..... A46B 2200/1046; A46B 2200/104; A46B 1/00; A46B 2200/1006; A46B 9/021  
See application file for complete search history.

*Primary Examiner* — George A Bugg  
*Assistant Examiner* — Tamara L Hahn  
(74) *Attorney, Agent, or Firm* — Keusey & Associates. P.C.

(56) **References Cited**

**U.S. PATENT DOCUMENTS**

1,120,476 A 12/1914 Hansen  
1,507,971 A 8/1923 Lomp  
1,694,364 A 12/1928 Albright  
1,923,884 A 8/1933 Pushee  
2,049,365 A 7/1936 Follett  
2,117,174 A 5/1938 Jones

(57) **CLAIM**

The ornamental design for an angled chisel brush, as shown and described.

**DESCRIPTION**

FIG. 1 is a top, front, left side perspective view of my new design of an angled chisel brush.  
FIG. 2 is a front, top side perspective view thereof.  
FIG. 3 is a left side elevational view thereof; the right side elevational view being a mirror image thereof.  
FIG. 4 is a front side elevational view thereof.  
FIG. 5 is a back side elevational view thereof.  
FIG. 6 is a top plan view thereof; and,  
FIG. 7 is a bottom plan view thereof.  
The broken lines showing the ferrule and handle in FIGS. 1, 2, 3, 4, 5, and 7 are included to show environmental structure and form no part of the claimed design.

**1 Claim, 2 Drawing Sheets**

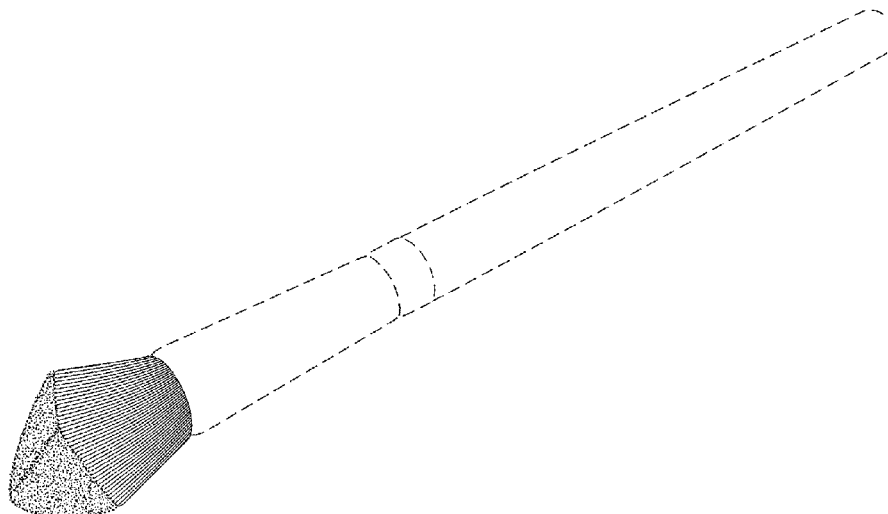

(56)

References Cited

U.S. PATENT DOCUMENTS

4,454,622	A	6/1984	Poppendieck	7,895,698	B2	3/2011	Mink	
4,483,036	A	11/1984	Sayklay	8,104,132	B2	1/2012	Mink	
4,998,315	A	3/1991	Pessis	D679,506	S	4/2013	Hile	
4,998,545	A	3/1991	Hiromura	D710,617	S	8/2014	Mink	
5,001,803	A	3/1991	Discko, Jr.	D713,646	S	9/2014	Mink	
5,373,599	A	12/1994	Lemon et al.	D714,558	S	10/2014	Mink	
5,507,063	A	4/1996	Hirsch	D739,148	S *	9/2015	Lim	D4/135
5,689,872	A	11/1997	Forsline	D762,988	S *	8/2016	Xavier	D4/127
5,799,353	A	9/1998	Oishi et al.	D778,620	S *	2/2017	Jain	D4/135
5,896,620	A	4/1999	Mink	D782,198	S *	3/2017	Hwang	D4/127
6,012,463	A *	1/2000	Mitchell, Jr. .... A45D 27/22 132/200	D787,194	S *	5/2017	Hwang	D4/127
				D787,833	S *	5/2017	Jain	D4/127
6,039,051	A	3/2000	Dorf	D798,604	S *	10/2017	Hwang	D4/127
6,108,847	A	8/2000	Cueman et al.	D801,058	S *	10/2017	Xavier	D4/135
6,176,631	B1	1/2001	Gueret	D851,329	S *	6/2019	Celia	D28/7
D439,415	S	3/2001	Mink et al.	D852,414	S *	6/2019	Celia	D28/7
6,210,060	B1	4/2001	Gueret	D857,400	S *	8/2019	Nicoline	D4/138
D442,369	S	5/2001	Damiano	D875,308	S *	2/2020	Suzuki	D28/7
6,308,371	B1	10/2001	Forsline	2001/0042281	A1	11/2001	Forsline	
D450,189	S	11/2001	Mink et al.	2001/0052160	A1	12/2001	Dorf	
D450,931	S	11/2001	Mink et al.	2002/0083953	A1	7/2002	Dorf	
D452,994	S	1/2002	Mink et al.	2003/0035953	A1	2/2003	Weihrauch	
D454,001	S	3/2002	Mink et al.	2003/0150073	A1	8/2003	Jang	
6,367,114	B1	4/2002	Babkowski	2004/0003478	A1	1/2004	Mink	
D463,136	S	9/2002	Mink	2004/0168700	A1	9/2004	Dort	
6,513,183	B2	2/2003	Dort	2005/0218033	A1	1/2005	Curtis	
D471,018	S	3/2003	Mink	2005/0133947	A1	6/2005	Jang	
6,604,531	B2	8/2003	Nakamura et al.	2005/0257337	A1	11/2005	Clegg et al.	
D479,917	S	9/2003	Mink	2007/0151061	A1	7/2007	Mink et al.	
D479,918	S	9/2003	Mink	2010/0095973	A1	4/2010	Shrier et al.	
D480,217	S	10/2003	Mink	2010/0101035	A1	4/2010	Nakamura	
D480,218	S	10/2003	Mink	2013/0098382	A1	4/2013	Martin et al.	
6,779,532	B2	8/2004	Dorf	2013/0125921	A1	5/2013	Celia	
D559,548	S	1/2008	Dovellos	2013/0199556	A1	8/2013	Lim	
D562,566	S	2/2008	Mink	2014/0332027	A1 *	11/2014	Lim	A46B 9/026 132/320
				2016/0066681	A1 *	3/2016	Xavier	A46B 9/021 15/207.2

\* cited by examiner

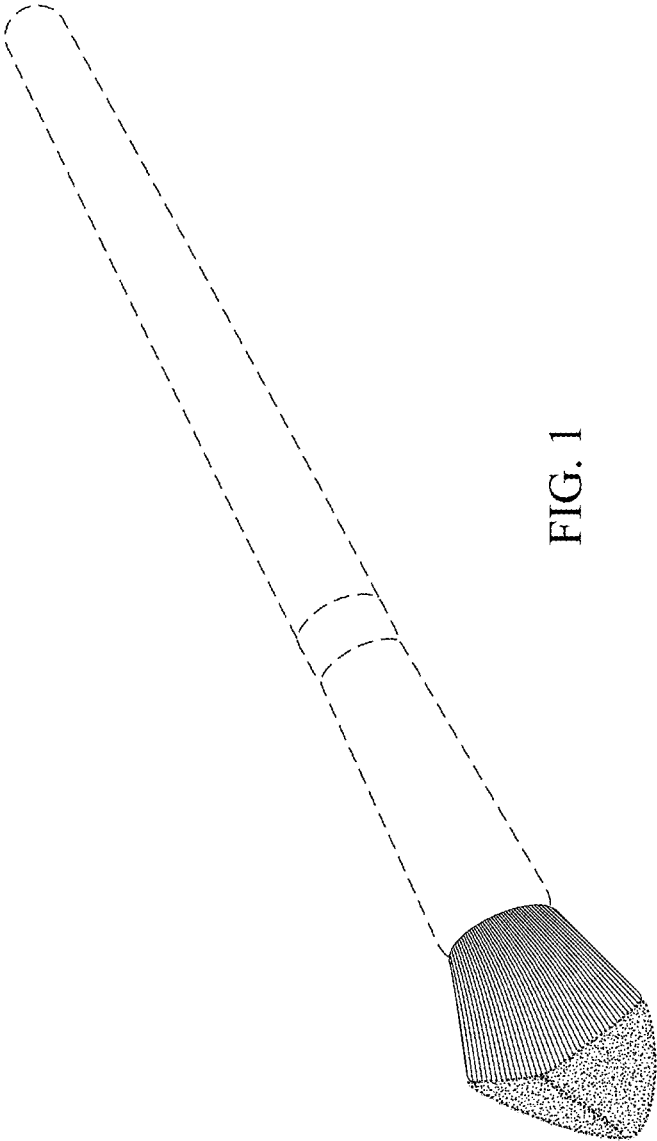

FIG. 1

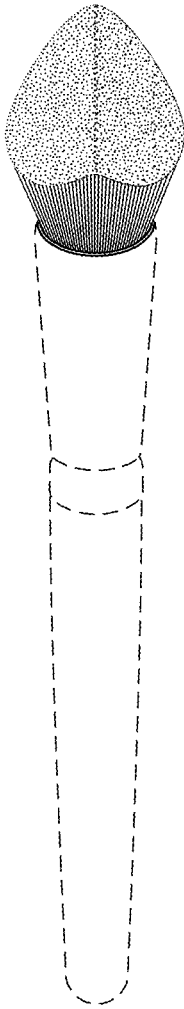

FIG. 2

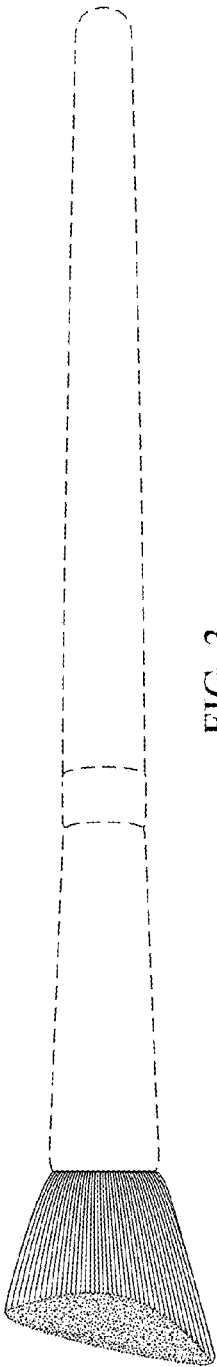

FIG. 3

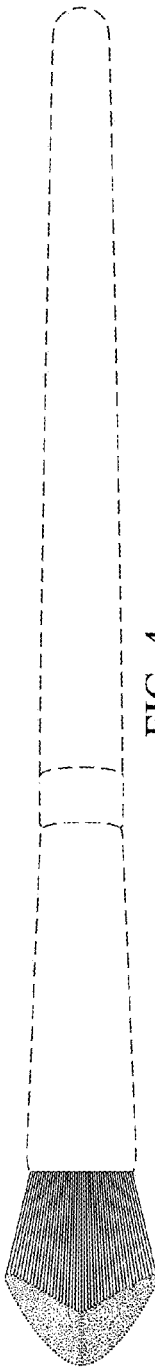

FIG. 4

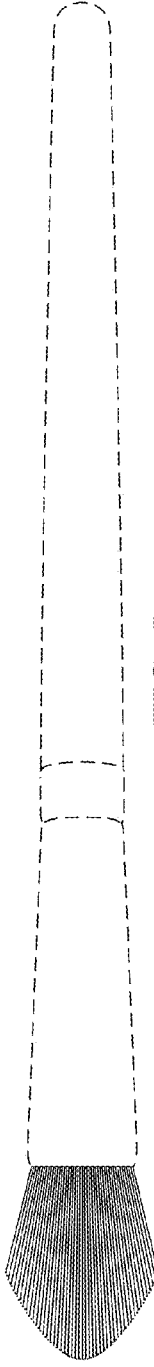

FIG. 5

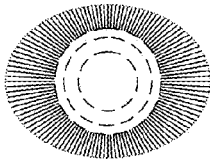

FIG. 7

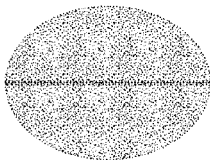

FIG. 6