



(19) **United States**

(12) **Patent Application Publication**

**Garrett et al.**

(10) **Pub. No.: US 2002/0013844 A1**

(43) **Pub. Date: Jan. 31, 2002**

(54) **SERVICE SELECTION IN A SHARED ACCESS NETWORK SUPPORTING QUALITY OF SERVICE**

(76) Inventors: **John W. Garrett**, Neshanic Station, NJ (US); **Charles Robert Kalmanek JR.**, Short Hills, NJ (US); **Han Q. Nguyen**, Marlboro, NJ (US); **Kadangode K. Ramakrishnan**, Berkeley Heights, NJ (US)

Correspondence Address:  
**Samuel H. Dworetzky**  
**AT&T CORP.**  
**P.O. Box 4110**  
**Middletown, NJ 07748-4100 (US)**

(21) Appl. No.: **09/812,444**

(22) Filed: **Mar. 20, 2001**

**Related U.S. Application Data**

(63) Non-provisional of provisional application No. 60/190,633, filed on Mar. 20, 2000. Non-provisional of provisional application No. 60/190,636, filed on Mar. 20, 2000.

**Publication Classification**

(51) **Int. Cl.<sup>7</sup>** ..... **G06F 15/173**  
(52) **U.S. Cl.** ..... **709/225; 709/229**

(57) **ABSTRACT**

It is an object of the invention to enable multiple services or service providers to share the facilities of an access network infrastructure providing physical connectivity to subscribers. A network access device advantageously may be used in communication network services with a service or service provider that is separate from the operator of the access network infrastructure.

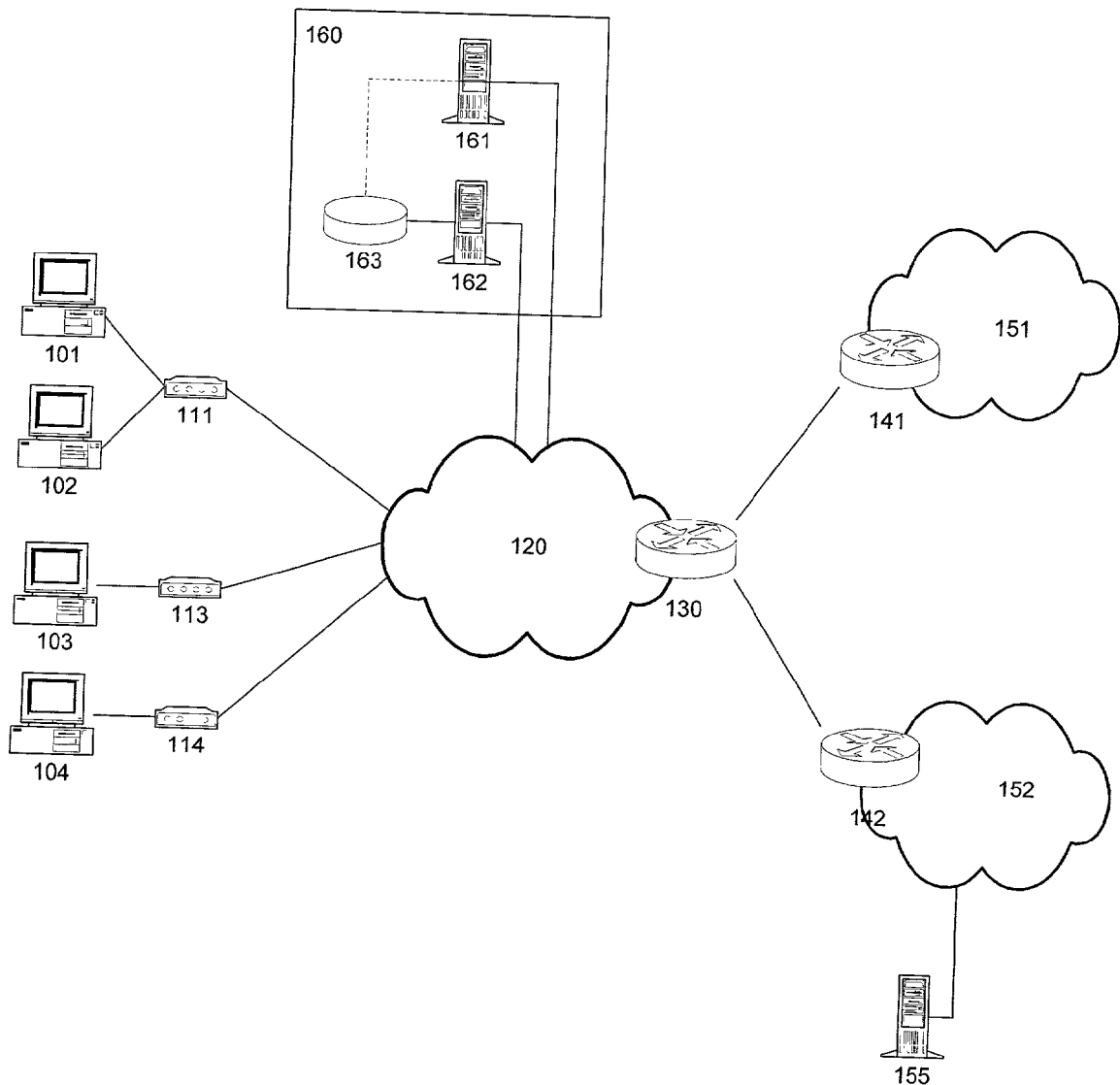

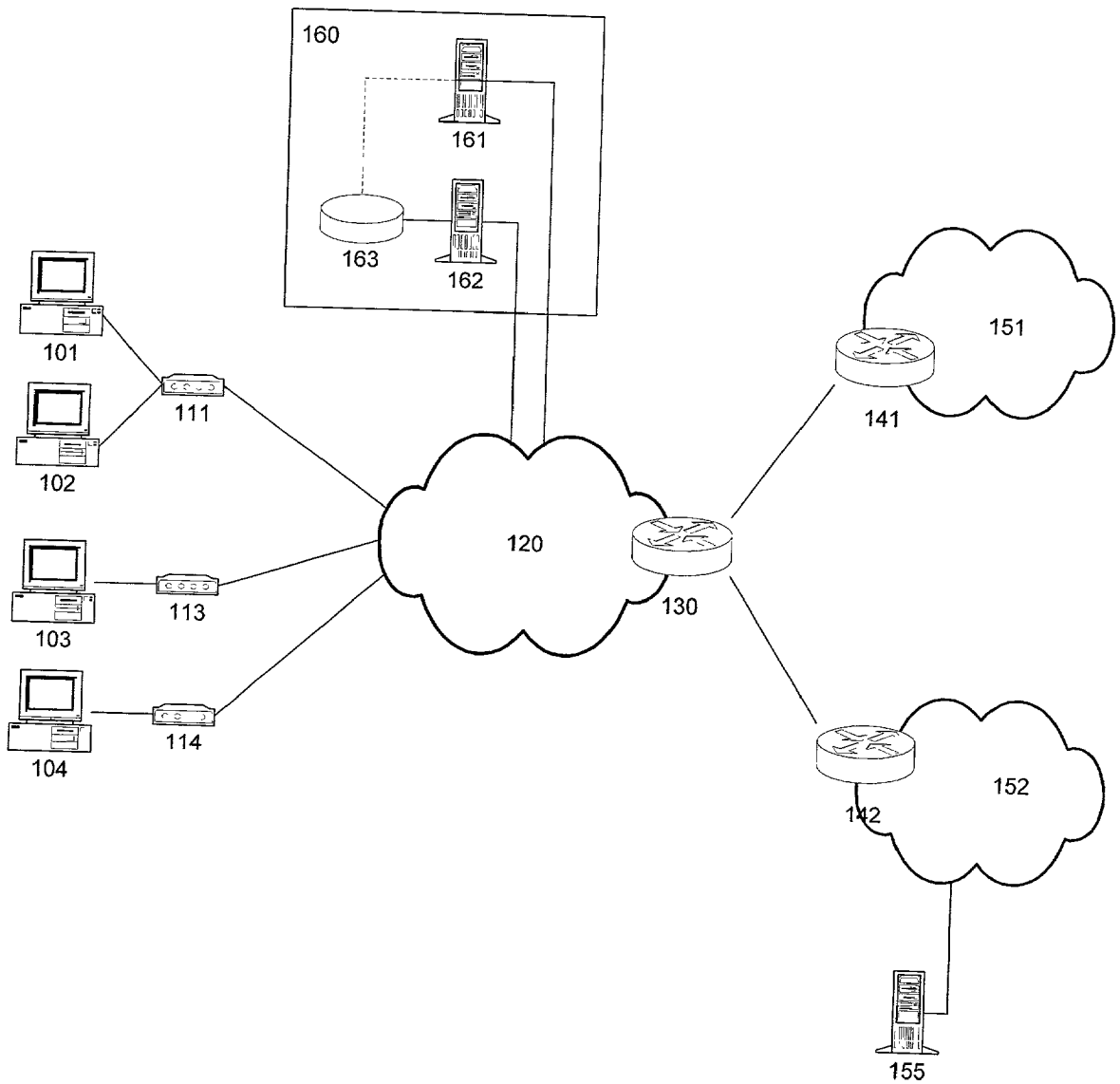

FIG. 1

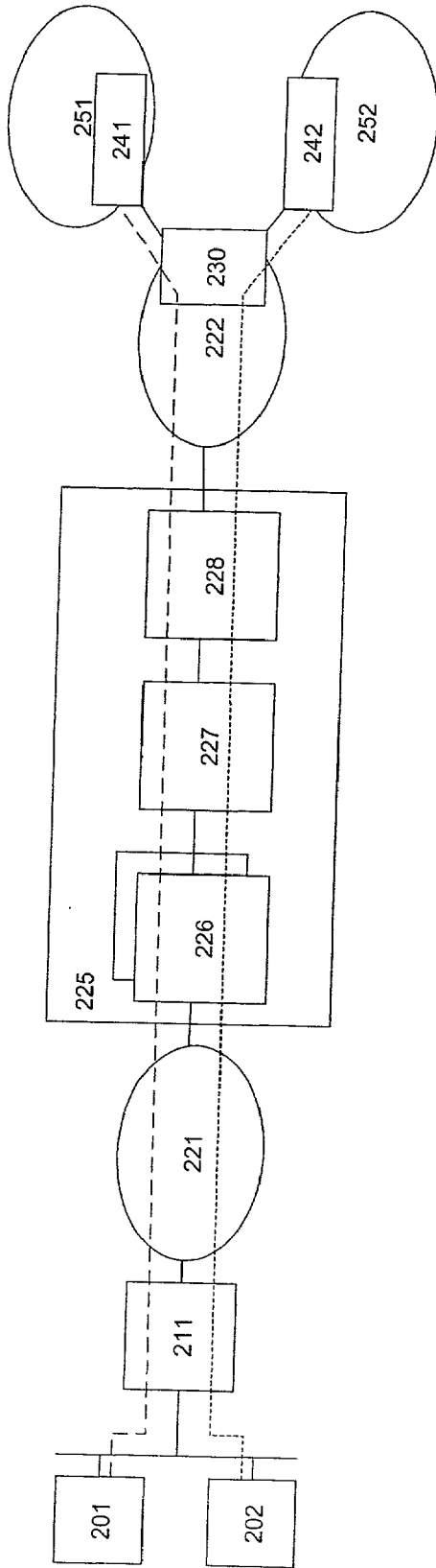

FIG. 2A

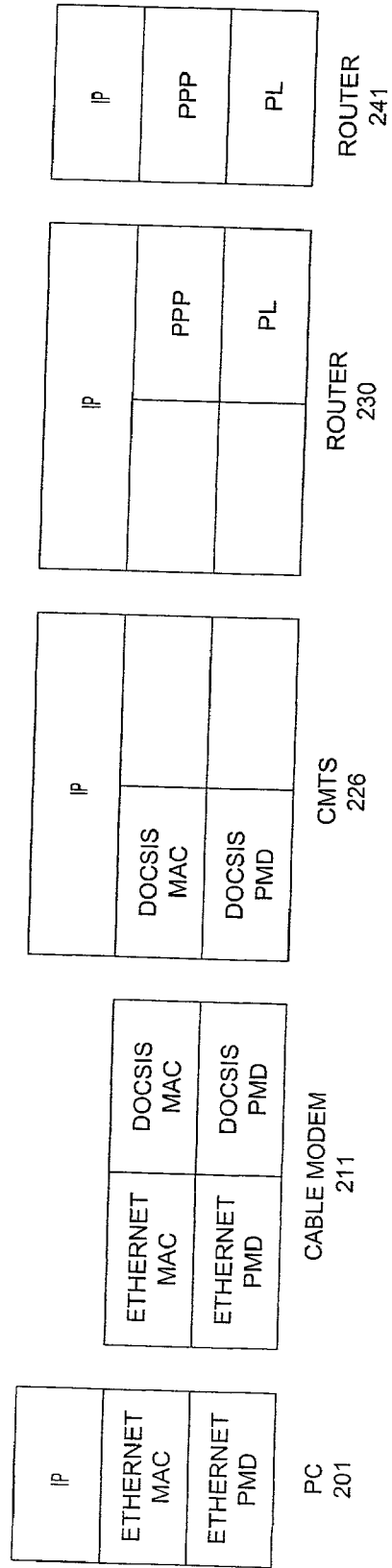

FIG. 2B

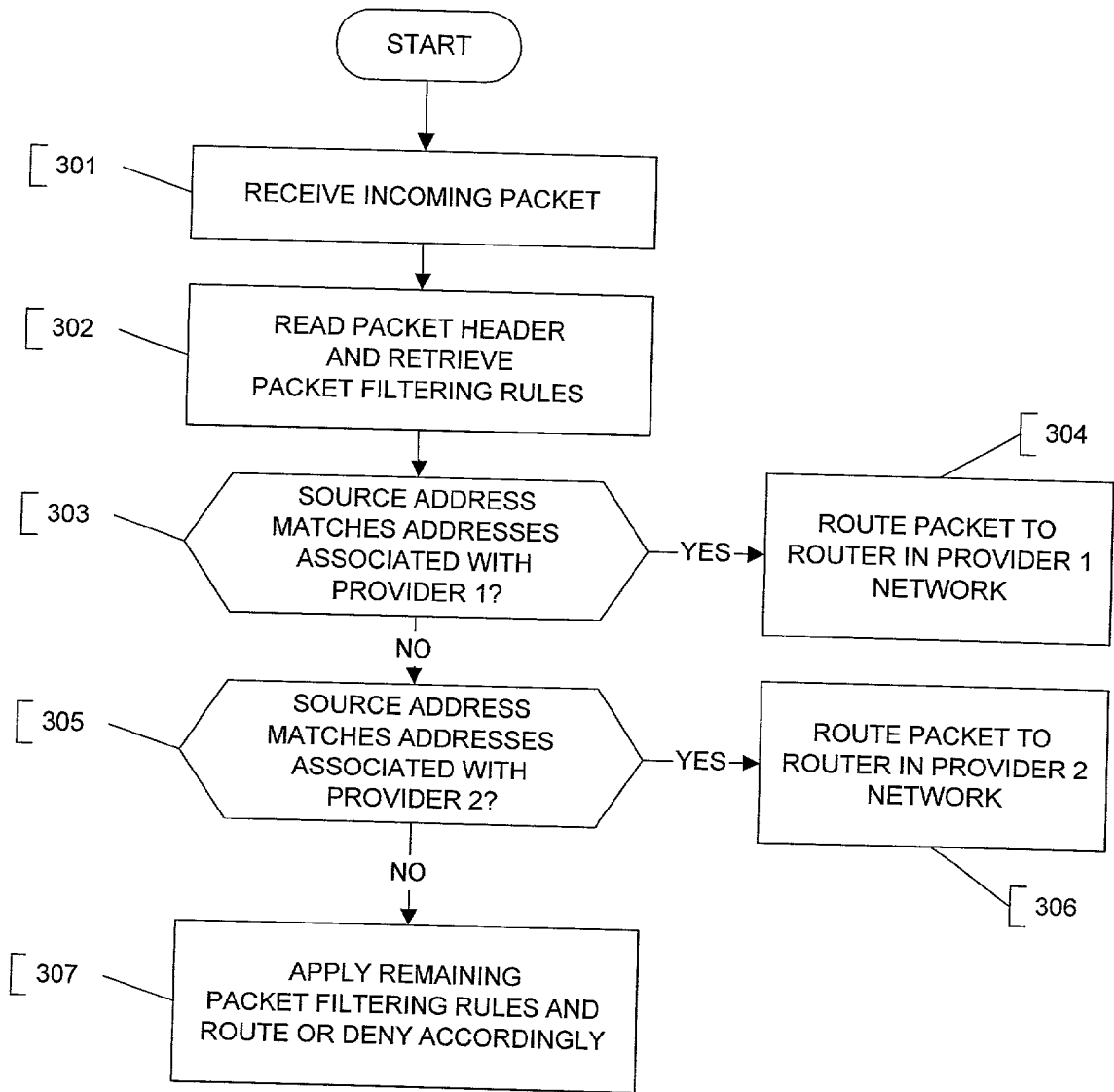

FIG. 3

```
401 interface cable x/y
402 ...
403 ip policy route-map source_route
404 ...
405 !

406 route-map source_route
407 match ip address isp1_subs
408 set ip next-hop isp1_next-hop_address
409 match ip address isp2_subs
410 set ip next-hop isp2_next-hop_address
411 ...
412 access-list isp1_subs permit isp1_prefix1
isp1_prefix1_wildcard any any
413 access-list isp1_subs permit isp1_prefix2
isp1_prefix2_wildcard any any
414 ...
```

FIG. 4

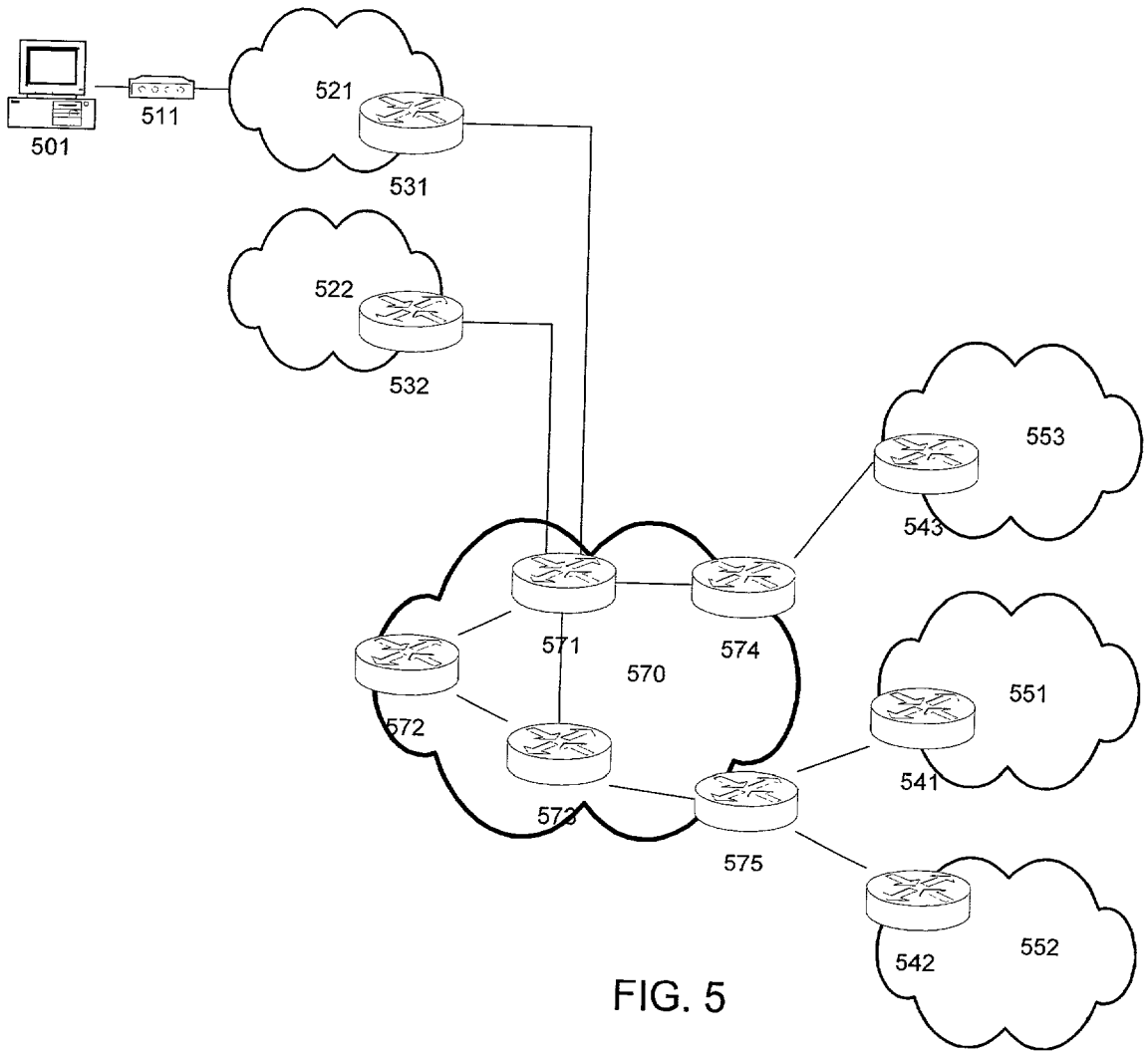

FIG. 5

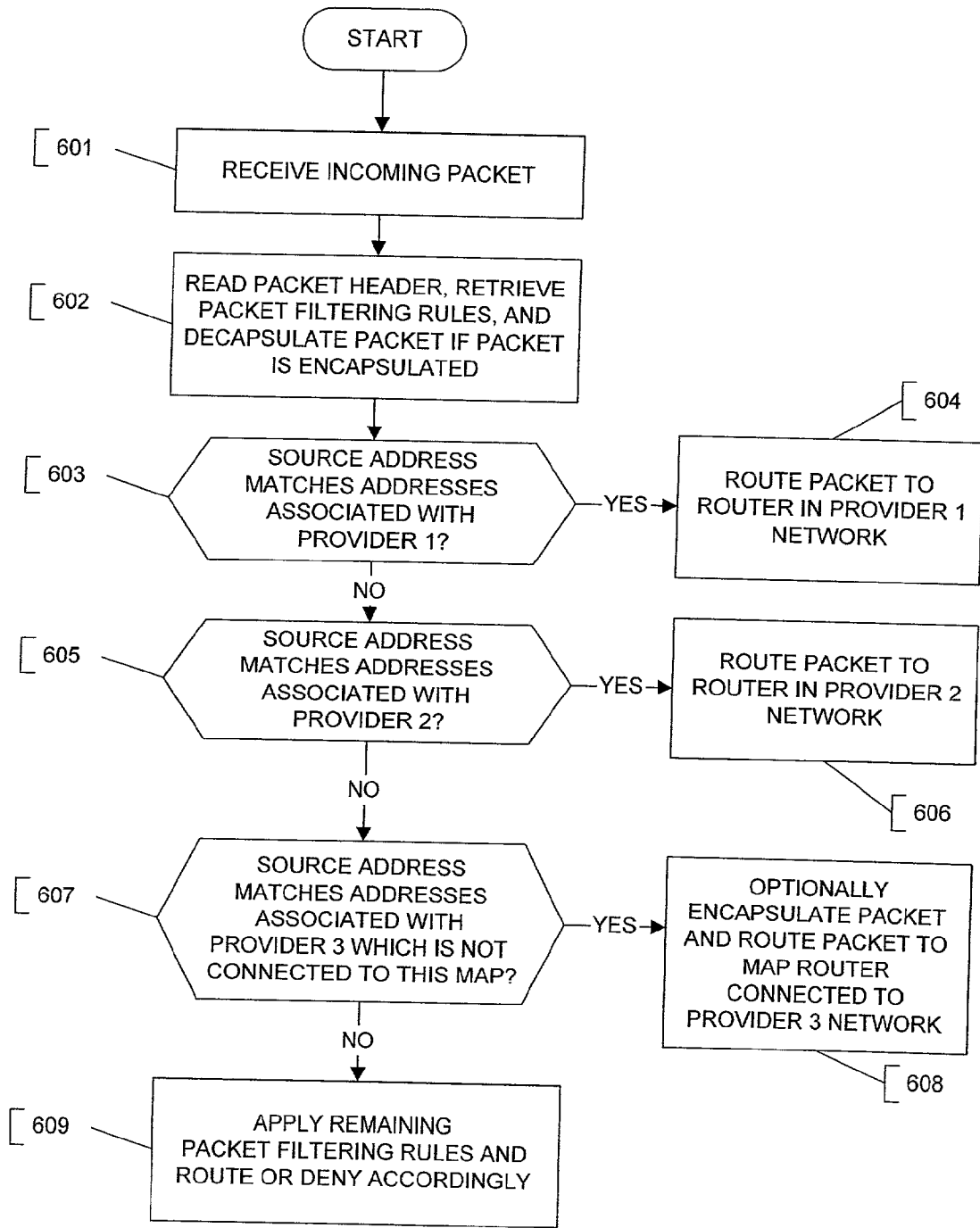

FIG. 6

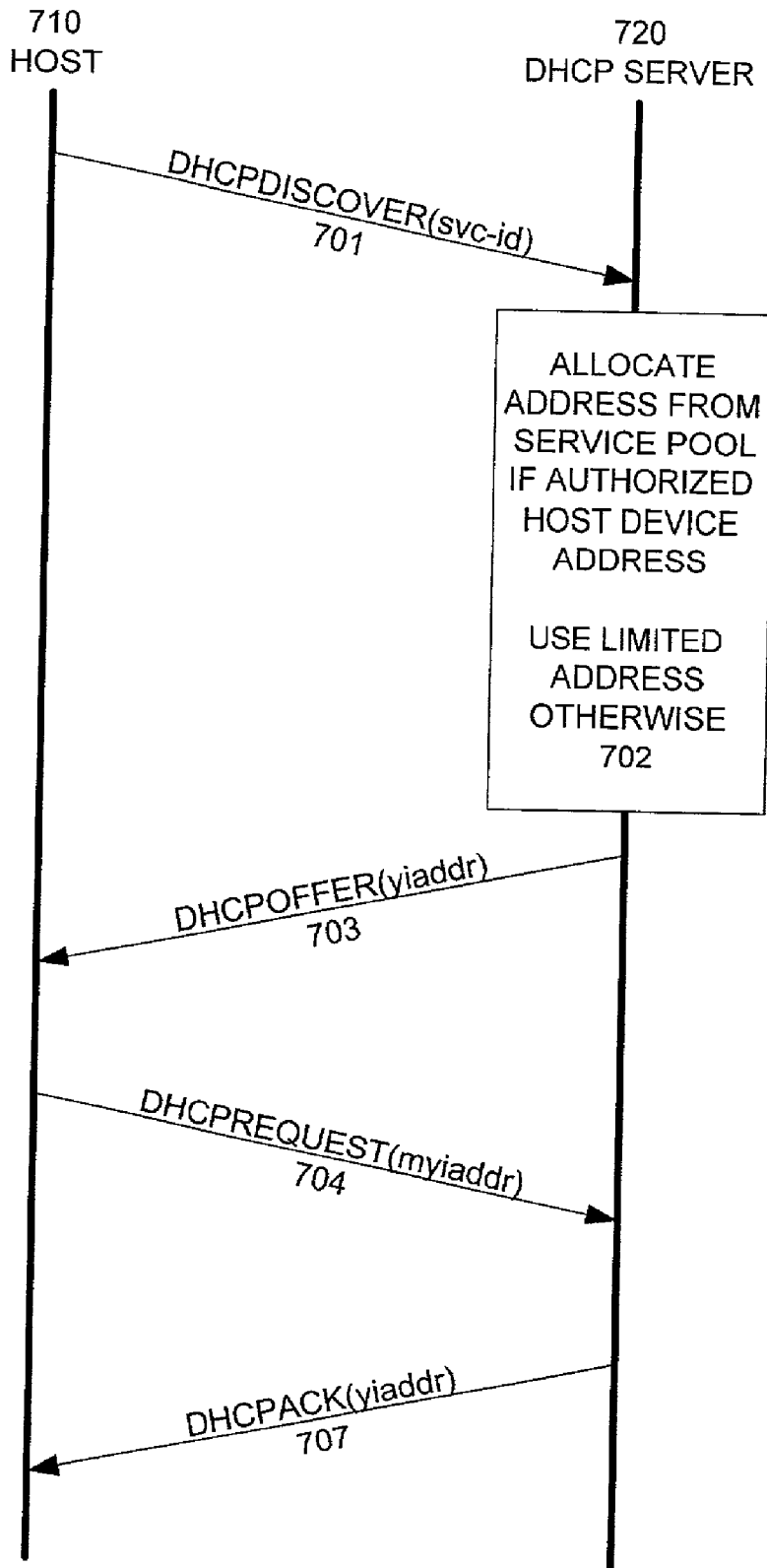

FIG. 7



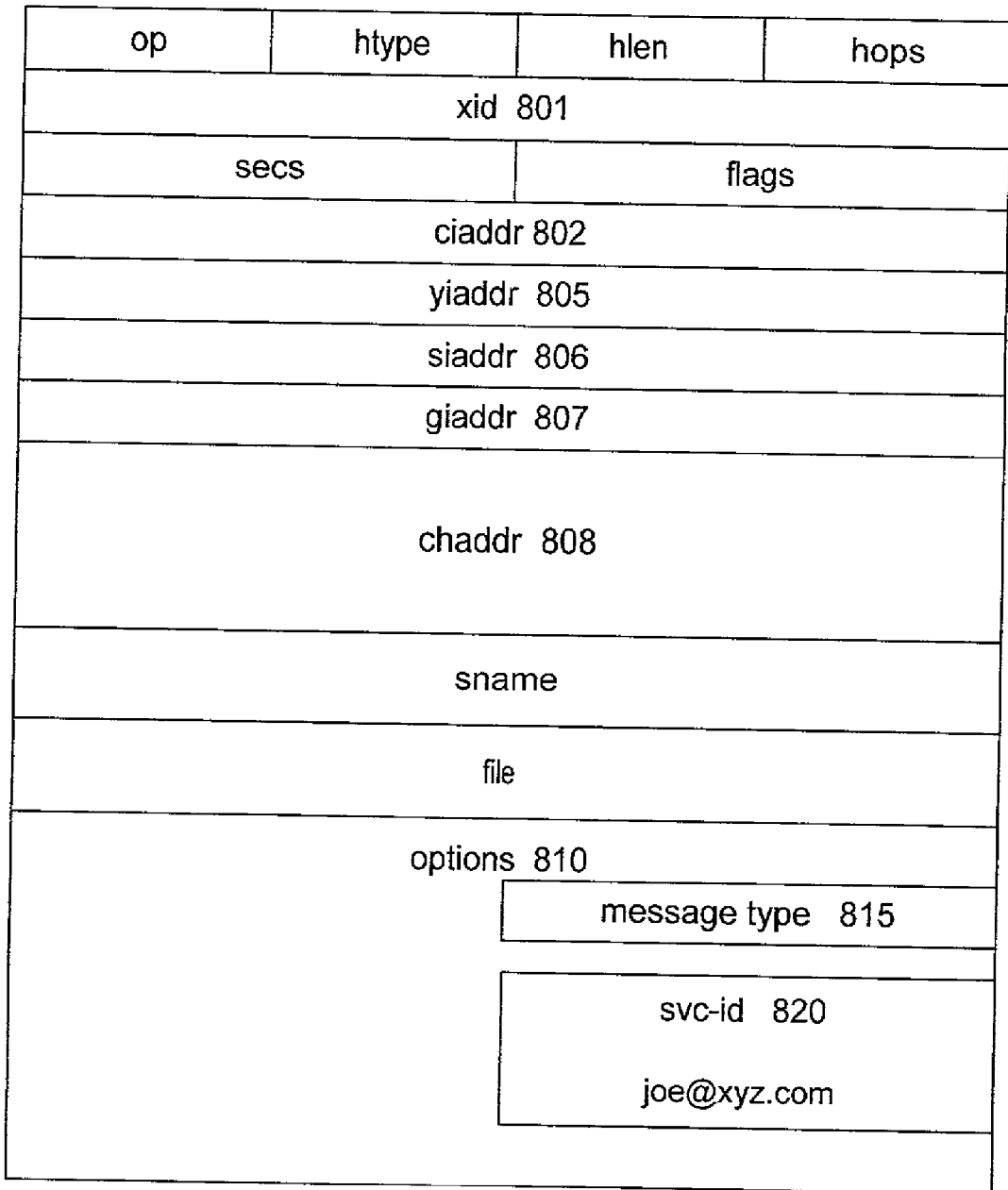

FIG. 8

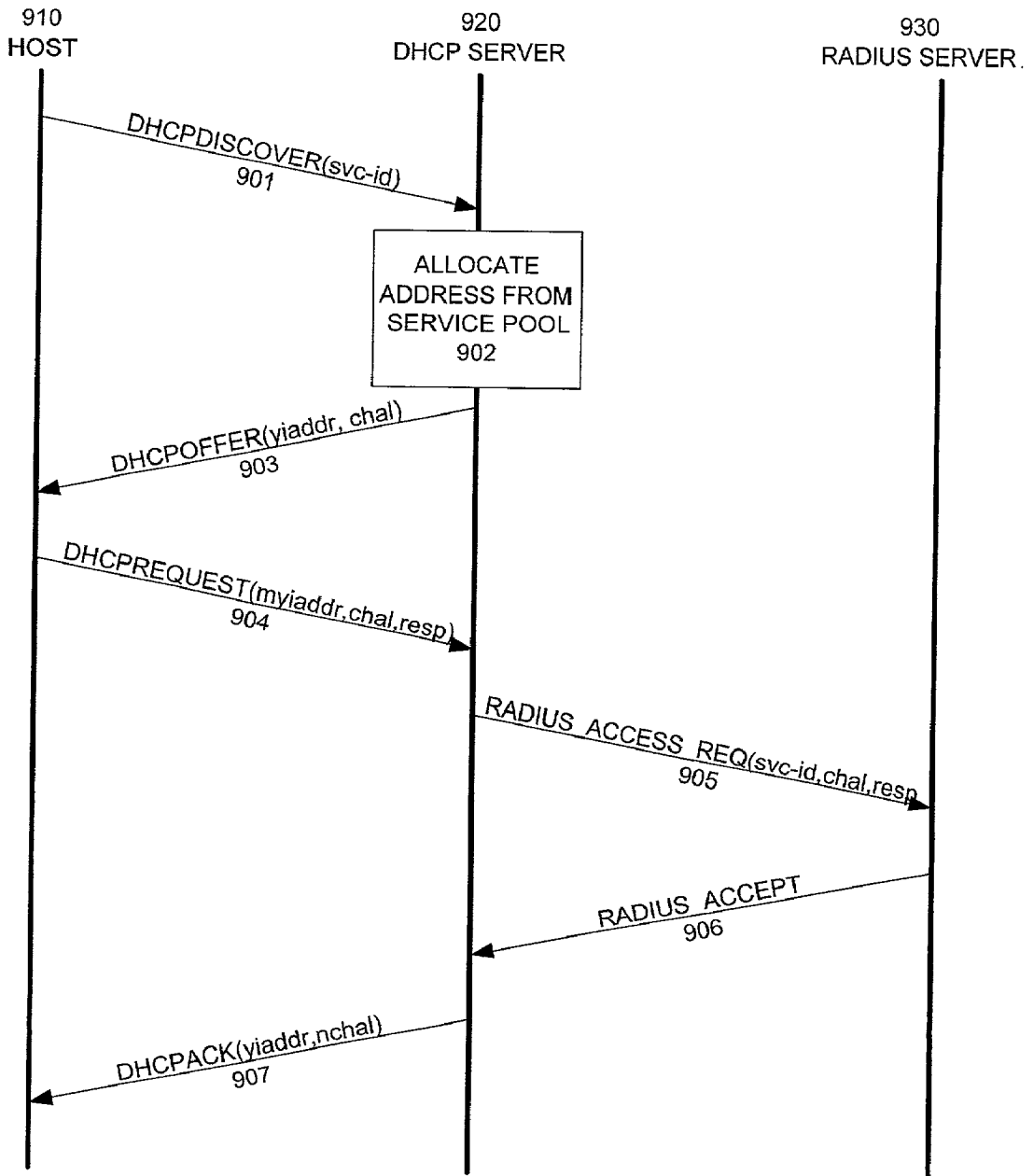

FIG. 9

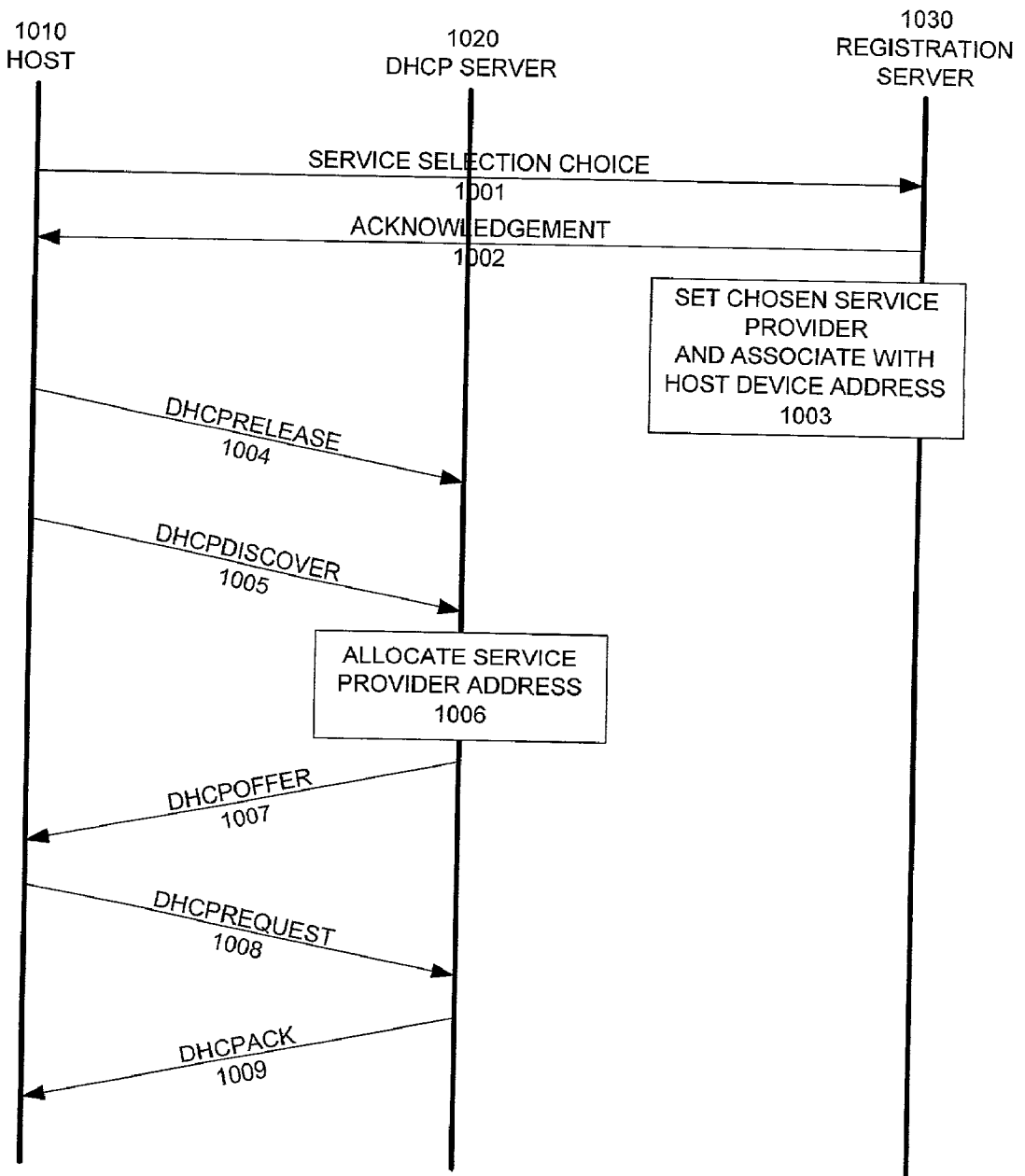

FIG. 10

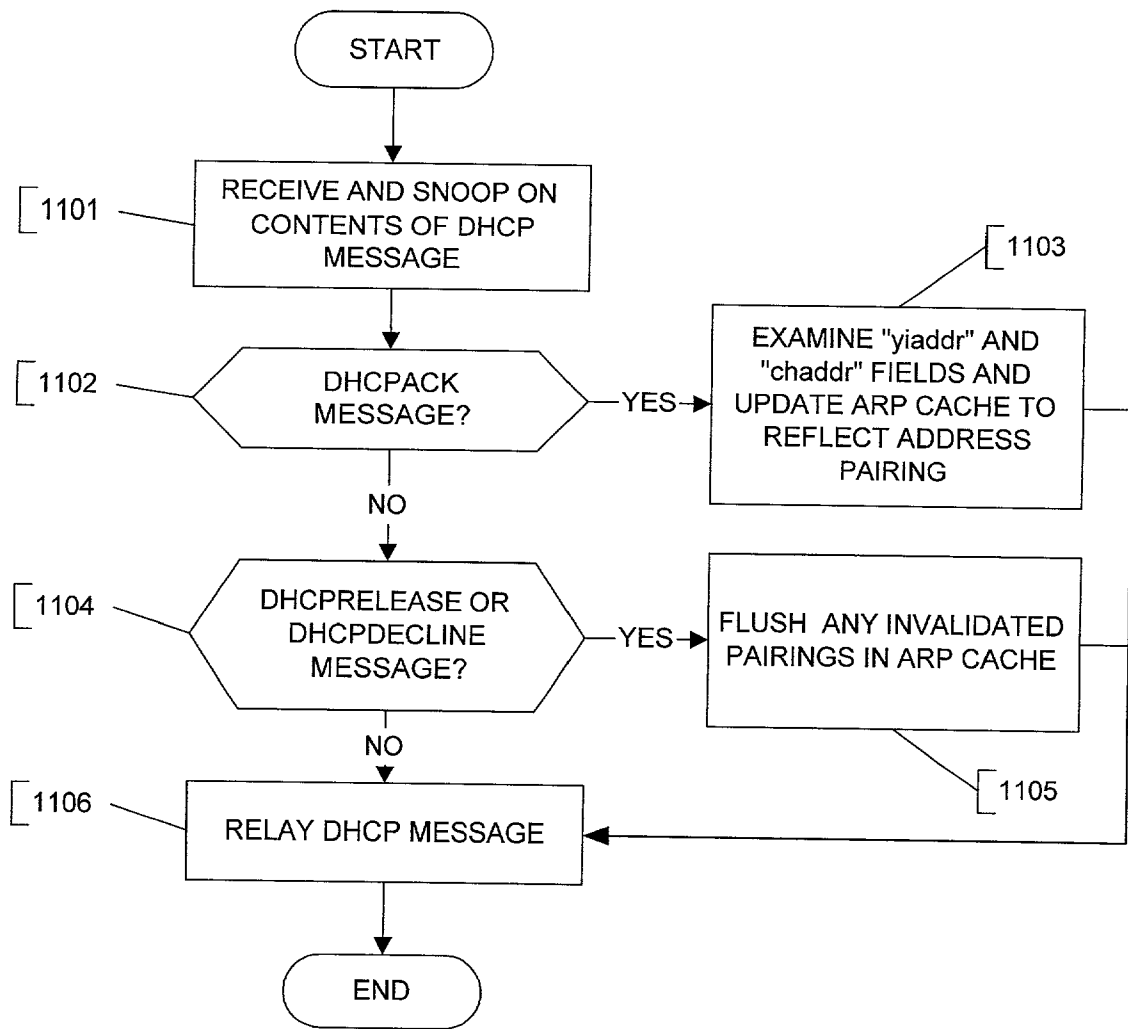

FIG. 11

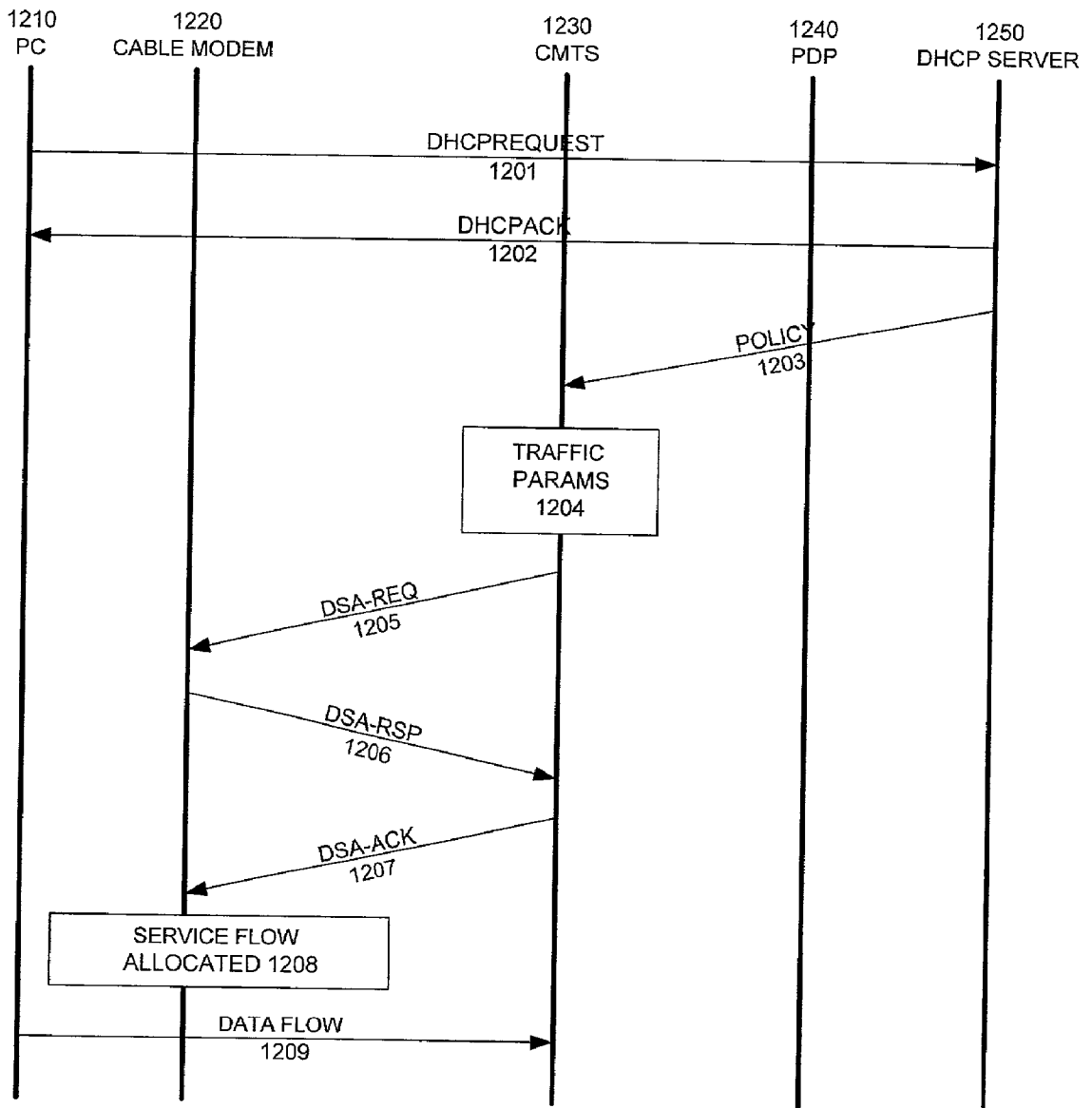

FIG. 12

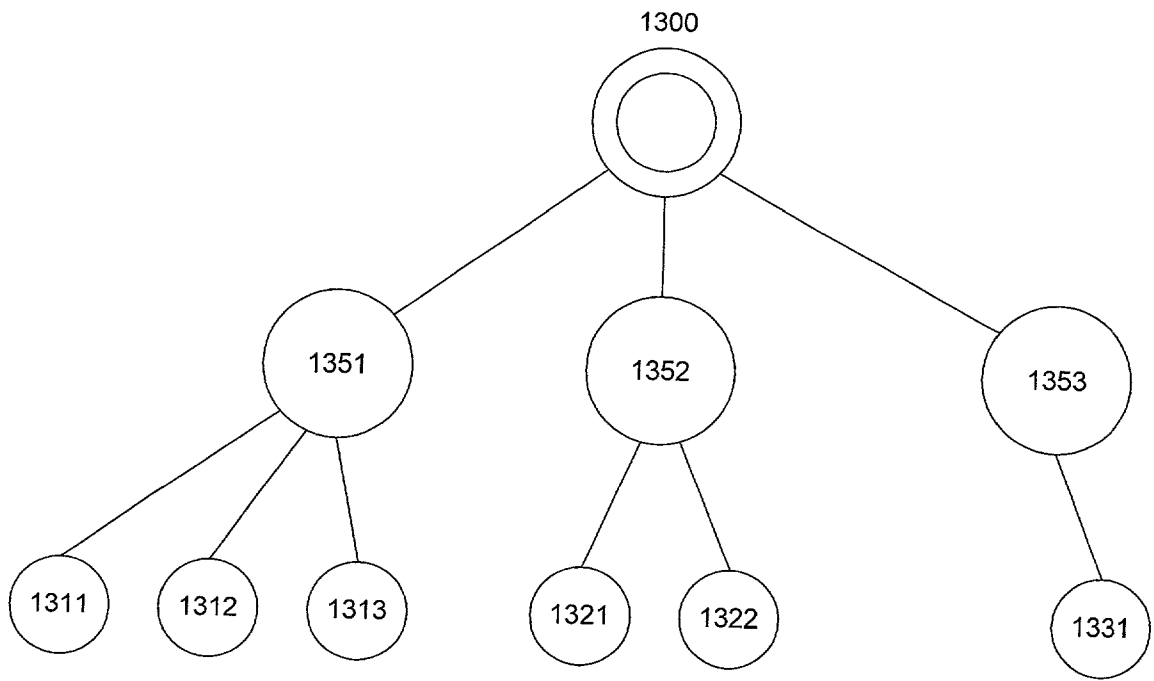

FIG. 13

## SERVICE SELECTION IN A SHARED ACCESS NETWORK SUPPORTING QUALITY OF SERVICE

### FIELD OF THE INVENTION

[0001] The present invention relates generally to communication network services, and, more particularly, to providing multiple services in a communication network.

### BACKGROUND OF THE INVENTION

[0002] Customers of communication network services often desire access to a plurality of different services and different service providers. For example, when using a dial-up connection to a packet-switched data network such as the Internet, a customer can choose from multiple service providers by dialing different telephone numbers in the PSTN. The physical path from the customer to the customer's Internet Service Provider (ISP) is dedicated to the connection for the duration of the telephone call. The ISP assigns an IP address to the customer and can link the authenticated customer and the assigned IP address to the physical address (e.g. dial-up modem) used by the customer. With this linkage, the ISP can ensure the customer only uses the address authorized by the ISP and can use the customer's IP address to manage access to the ISP's services. The physical connection between a customer and the ISP, as well as the linkage to IP address assignment and customer authentication is terminated when the dial-up connection is terminated.

[0003] Constrained by the physical capacity of these temporary connections across the PSTN, many service providers are moving to high-speed access architectures (e.g., digital subscriber line (DSL), wireless, satellite, or cable) that provide dedicated physical connectivity directly to the subscriber and under the control of the ISP. These alternatives to shared access through the switched telephone network, however, do not lend themselves to shared access by multiple services and/or service providers.

### SUMMARY OF THE INVENTION

[0004] It is an object of the invention to enable multiple services or service providers to share the facilities of an access network infrastructure providing physical connectivity to subscribers. In accordance with an embodiment of the invention, a router situated at an edge of an access network forwards packets to any of a plurality of packet-switched service networks. The router uses a policy based on the source address of the packets to determine to which service network to forward the packet. Each network access device is assigned a network address, which is associated with a particular service or service provider to which the user of the device is subscribed. The network access device advantageously may be used in communication network services with a service or service provider that is separate from the operator of the access network infrastructure.

[0005] In accordance with another aspect of the invention, interconnections between a plurality of packet-switched service networks and an access network are localized into managed access points. Routers in the access network can advantageously forward packets to the managed access points using conventional routing procedures, thus enabling the access network to provide "local" packet-switched services. The managed access points use source address-based

policy to determine to which service network to forward a packet. Where a packet arrives at a managed access point that is not connected to the correct service network, the managed access point can use packet encapsulation or some other form of tunneling to redirect the packet to the correct managed access point. The present invention, among other advantages, does not require interconnection points to each service network at every regional access network site.

[0006] In accordance with another aspect of the invention, a configuration server, upon receiving a request from a network access device selecting a particular service, allocates a network address from a pool of addresses associated with the service and assigns the network address to the network access device using a host configuration protocol, such as DHCP. In accordance with an embodiment of the invention, the configuration server authenticates the network access device before assigning a network address. In accordance with another embodiment of the invention, the configuration server transmits authentication information received from the network access device to a server in the service network responsible for authentication. In accordance with another embodiment of the invention, the host configuration protocol messages acknowledging allocation of a network address to the service subscriber's network access device are used to create entries in an address resolution protocol cache in order to restrict access to the access network infrastructure to those network access devices that are properly registered and authenticated. In accordance with another embodiment of the invention, the host configuration protocol acknowledging allocation of the network address to the service subscriber's network access device are used to initiate the distribution of service policies to policy enforcement points in order to enable differentiated quality-of-support for different subscribers of different services or service providers. The present invention, among other advantages, enables the network addresses—which ultimately determine the service network utilized by the particular network access device—to be allocated and re-assigned dynamically.

[0007] These and other advantages of the invention will be apparent to those of ordinary skill in the art by reference to the following detailed description and the accompanying drawings.

### BRIEF DESCRIPTION OF THE DRAWINGS

[0008] FIG. 1 illustrates an interconnection of packet-switched service networks and an access network embodying principles of the invention.

[0009] FIG. 2A and FIG. 2B is conceptual representation of an example embodiment illustrating principles of the invention based on an HFC access architecture with corresponding end-to-end protocol layers.

[0010] FIG. 3 is a flowchart of processing performed at a policy router, in accordance with an embodiment of the invention.

[0011] FIG. 4 is a simplified example of router configuration instructions.

[0012] FIG. 5 illustrates an interconnection of packet-switched service network, regional access networks, and a packet-switched access network, embodying principles of another aspect of the invention.

[0013] FIG. 6 is a flowchart of processing performed at a policy router acting as a managed access point, in accordance with another embodiment of the invention.

[0014] FIG. 7 is a timeline diagram of messages exchanged in the assignment of a network address associated with a particular service to a network access device, in accordance with a preferred embodiment of another aspect of the invention.

[0015] FIG. 8 is a conceptual representation of a DHCP message exchanged between the network access device and a DHCP server.

[0016] FIG. 9 is a timeline diagram of messages exchanged in the assignment of a network address associated with a particular service to a network access device, in accordance with a preferred embodiment of another aspect of the invention.

[0017] FIG. 10 is a timeline diagram of messages exchanged in the assignment of a network address associated with a particular service to a network access device, in accordance with a preferred embodiment of another aspect of the invention.

[0018] FIG. 11 is a flowchart of processing performed at a Cable Modem Termination System, exemplifying an embodiment of another aspect of the invention.

[0019] FIG. 12 is a timeline diagram of messages exchanged in the assignment of a service class to a subscriber, in accordance with a preferred embodiment of another aspect of the invention.

[0020] FIG. 13 is a conceptual diagram of a hierarchical link-sharing structure.

#### DETAILED DESCRIPTION

[0021] In FIG. 1, a plurality of subscribers operating network access devices 101, 102, 103, . . . 104 are provided access to communication network services, which are facilitated by a plurality of packet-switched data networks, shown in FIG. 1 as 151 and 152. Packet-switched data networks 151 and 152, referred to herein as "service networks," offer access to different services and/or are operated by different service providers. For example, service network 151 could provide packet-switched connectivity to public data networks while service network 152 could offer packet-switched telephony service (or the same public data network connectivity, but from a different service provider). The service networks, as is well known in the art, utilize a network addressing scheme to route datagrams to and from hosts: for example, where the service networks utilize the TCP/IP protocol suite, Internet Protocol (IP) addresses are assigned to each host and utilized in the process of routing packets from a source to a destination in the networks. See, e.g., "INTERNET PROTOCOL," IETF Network Working Group, RFC 791 (September 1981); S. Deering, R. Hinden, "Internet Protocol, Version 6 (IPv6) Specification," IETF Network Working Group, RFC 1883 (December 1995), which are incorporated by reference herein. The invention shall be described herein with particular reference to the TCP/IP protocol suite and IP addresses, although those skilled in the art would readily be able to implement the invention using any of a number of different communication protocols.

[0022] The network access devices 101 . . . 104 are typically customer premises equipment (CPE) such as a personal computer, information appliance, personal data assistant, data-enabled wireless handset, or any other type of device capable of accessing information through a packet-switched data network. Each network access device 101 . . . 104 is either connected to or integrated with a network interface unit 111 . . . 114, e.g. a modem, which enables communication through an access network infrastructure, shown as 120 in FIG. 1. Each network access device is assigned an IP address which, in accordance with an aspect of the invention, is associated with a particular service or service provider to which the user of the device is subscribed. For example, network access device 101 is assumed to have been assigned, for purposes of the description herein, an IP address associated with a service provider operating service network 151. As further described herein, it is advantageous to provide a service activation system 160 which advantageously permits the dynamic allocation, assignment, and reassignment of IP addresses to the plurality of network access devices based on customer subscriptions to particular services.

[0023] The network access device 101 communicates with the service network 151 through the access network infrastructure 120, which, in accordance with aspects of the invention, is capable of recognizing and directing traffic to the proper service network. The access network infrastructure 120 advantageously can be operated and maintained by an entity that is the same as or different from the entities operating and maintaining the service networks 151 and 152. In accordance with an embodiment of an aspect of the present invention, the different IP-based services offered by the different service networks 151 and 152 utilize shared layer one and layer two resources in the access network 120. Layer three routing procedures, however, are modified to permit IP traffic from network access device 101 to flow to the correct subscribed service network 151. The access network 120 has a router 130 on the edge of the access network. The router 130 has a first interface with a connection to a router 141 in service network 151 and a second interface with a connection to a router 142 in service network 152. As further described herein, the router processes packets and is capable of directing traffic to the proper service network.

[0024] FIG. 2A shows an exemplary access architecture based on a hybrid fiber coaxial (HFC) access network. As is known in the art, each network interface device 201 . . . 202 is either connected to or integrated with a cable modem 211 which enables communication through the HFC network 221. In accordance with the Data Over Cable Service Interface Specification (DOCSIS), a Cable Modem Termination System (CMTS), shown as 225 in FIG. 2A, communicates with the cable modems 211 and manages access to both upstream and downstream cable capacity on the HFC networks 221. See, e.g., "Data-Over-Cable Service Interface Specifications: Cable Modem Termination System—Network Side Interface Specification," Cable Television Laboratories, Inc., SP-CMTS-NSI-I01-960702; "Data-Over-Cable Service Interface Specifications: Cable Modem to Customer Premise Equipment Interface Specification," Cable Television Laboratories, Inc., SP-CMCI-C02C-991015; "Data-Over-Cable Service Interface Specifications: Baseline Privacy Plus Interface Specifications," Cable Television Laboratories, Inc., SP-BPI+-I06-001215, which are



incorporated by reference herein. The CMTS 225 manages the scheduling of both upstream and downstream transmission and allocates cable capacity to individual customers identified by a Service IDs (SIDs). The CMTS 225 can have an integrated router 228 or can be a separate device 226 that bridges to a fast Ethernet switch 227 which connects to the router 228. The IP router 228 provides connectivity to an IP network 222, which further comprises the router 230 (corresponding to router 130 in FIG. 1) which interfaces to IP routers 241 and 242 in service networks 251 and 252, respectively. Accordingly, the HFC network 221, the CMTS 225, and the IP network 222 correspond to the access network infrastructure 120 shown in FIG. 1. FIG. 2B shows a conceptual diagram of the end-to-end communication protocol stack from a network access device 201 (101) to a router 241 (141) in service provider's network 251 (151). As is known in the art, the lowest layer deals with the physical layer (PL) of the protocol stack, e.g. the Ethernet physical media device (PMD) layer; the second layer deals with the data link layer, e.g. the Ethernet Media Access Control (MAC) layer; and the third layer in the protocol stack deals with the network layer, e.g. the IP layer. The following aspects of the invention deal with modifications to routing processes in the network layer of the protocol stack.

[0025] Router 130 in the access network 120 in FIG. 1 (corresponding to IP router 230 in FIG. 2) separates the IP traffic to the multiple services or service providers as well as combines traffic from the multiple services or service providers. In accordance with an aspect of the invention, IP packets are routed from network access device 101 to the subscribed service network 151 using source address-based policy routing. Conventional routing is destination-based: the router consults an internal routing table which maps the destination addresses of all inbound packets to a physical interface address for use for outgoing packets. Policy routing schemes, however, will selectively choose different paths for different packets even where the packet's destination address may be the same. Since network access devices are assigned addresses associated with a particular network service provider, the source address based policy routing scheme ensures packets from a network access device will go to the appropriate service network. Conventional destination-based routing will ensure that packets addressed to a network access device will be routed to the appropriate service network. Note that this would require service providers to advertise their service address ranges to their peers.

[0026] FIG. 3 sets forth the processing performed at a router in the access network, e.g. router 130 in FIG. 1. At step 301, the router receives an incoming packet. At step 302, the router reads the packet header and retrieves the packet filtering rules, typically stored in an access list as further described below. At steps 303, 305, and 307, the router applies the packet filtering rules. At step 303, the router compares the source IP address in the packet header to a list of addresses allocated to subscribers of services of a first service provider, e.g. operating service network 151 in FIG. 1. If the source address matches one of these addresses, then at step 304 the router forwards the packet to a router in service network 151, e.g. router 141 in FIG. 1. At step 305, the router compares the source IP address in the packet header to a list of addresses allocated to subscribers of services of a second service provider, e.g. operating service network 152 in FIG. 1. If the source IP address matches one of these addresses, then at step 305 the router forwards the

packet to a router in service network 152, e.g. router 142 in FIG. 1. The router continues in this fashion with any other packet filtering rules identifying IP addresses allocated to subscribers of any other service providers. Assuming the IP source address does not match any such addresses associated with a service provider, at step 307, the router applies any remaining packet filtering rules and routes or denies the packet accordingly.

[0027] FIG. 4 sets forth an example of router configuration instructions written for the Cisco Internetworking Operating System (IOS), which is used pervasively on conventional IP routers. Only the relevant portions of the configuration instructions are shown. Lines 401 to 405 configure the interface to utilize policy routing. Lines 406 to 410 specify the particular policy, namely to set the next "hop" address to the router address of a router in a one of the service networks, i.e. "isp1\_next-hop\_address," if the source address matches a range of addresses allocated to subscribers of the services provided by the service network, i.e. "isp1\_subs." Lines 412 to 413 set forth access lists associating "isp1\_subs" with ranges of addresses expressed, by convention, as a source address and a mask portion, i.e., the above policy is applied by the router to any traffic with a subscriber source address expressed as "isp1\_prefix1" with a mask portion of "isp1\_prefix1\_wildcard".

[0028] The embodiment shown in FIG. 1 notably requires interconnection points to all relevant service networks at each edge of each regional access network. In accordance with another aspect of the invention, it is desirable to create a regional transport network of routers and to localize the interconnection between the service networks and the access infrastructure into managed access points. A managed access point is a physical location at which the interfaces to the service networks can be provided. Having one or a small plurality of managed access points advantageously allows service selection to be implemented without requiring network service providers to connect physical facilities into, for example, every cable head end in an HFC-based network—thereby reducing costs for both the access network infrastructure operator and the service network providers. Each router in the regional transport network can be configured with policy information and invoke source address routing to forward packets to the managed access point providing access to the relevant service network. By overriding normal routing procedures, however, these procedures may introduce potential routing loops absent significant coordination between the routers external to known routing protocols. This risk can be minimized by centralizing the policy routing function in a single router that provides the interfaces to the service networks.

[0029] FIG. 5 illustrates an embodiment of this aspect of the invention. Each network access device 501 is connected through a network interface unit 511 to one of a plurality of access networks, e.g. 521 and 522 in FIG. 5. Each access network has an edge router (531 and 532 respectively in FIG. 5) which connects the access network to a regional IP network of routers, represented abstractly in FIG. 5 as IP access network 570. It is advantageous to aggregate connections from groups of edge routers to a single aggregation router 571 in the IP access network 570, as shown in FIG. 5. Aggregation router 571 can then connect to other routers in the regional IP network 570, i.e. routers 572 . . . 573,

which can also be aggregation routers connecting to pluralities of edge routers. Routers 541, 542, . . . 543 in service networks 551, 552, . . . 553 connect to the IP network 570 at routers 574 and 575, which act as managed access points to the service networks. Only the managed access point routers, e.g. 575, need invoke policy routing based on packet source address. All intermediate routers within the IP access network 570, i.e. 571 . . . 573, use normal destination-based forwarding procedures for destinations that are not local to the network 570. No configuration of policy in the intermediate routers is necessary.

[0030] By locating the policy routing functions at the interfaces to the service networks, the access network infrastructure (whether reflected generally by 120 in FIG. 1 or, in the packet-switched context, as network 570 in FIG. 5) can provide access to “local” services available from within the access network infrastructure. For example, IP network 570 can provide access to “local” packet-switched services and operate independent of the source address assigned to the network access devices. Since the intermediate routers 571 . . . 573 all use conventional destination-based forwarding, network 570 will properly route local service packets along the correct routing paths. “Non-local” service packets, however, are routed towards the managed access point routers 575 and 574 and policy routed to the correct service network. Where the network 570 forwards to a single managed access point router or where each managed access point router has a connection to each service network, the managed access point router can forward packets in accordance with the policies described above. Where, however, there are service networks that connect to only a subset of the managed access points (e.g., in FIG. 5, where service network 553 only connects to managed access point router 574), packets can be redirected or “tunneled” to the correct managed access point in order to ensure that the packets arrive at the correct service network. The multiple interconnected managed access points can then provide a single “logical” inter-domain gateway, again permitting all other routers to use conventional destination-based routing procedures.

[0031] FIG. 6 sets forth a flowchart of the processing performed at a managed access point router, e.g. router 575 in FIG. 5, illustrating an embodiment of this aspect of the invention. The particular managed access point router 575 is assumed to be connected to two service networks, e.g. service networks 551 and 552 in FIG. 5, while a second managed access point router 574 provides access to a third service network, service network 553. At step 601, the router receives an incoming packet. At step 602, the router reads the packet header and retrieves the packet filtering rules, as well as decapsulates any encapsulated packets, as further described herein. At steps 603, 605, 607, and 609, the router applies the packet filtering rules. At step 603, the router compares the source IP address in the packet header to a list of addresses allocated to subscribers of services of a first service provider, e.g. operating service network 551 in FIG. 5. If the source address matches one of these addresses, then at step 604 the router forwards the packet to a router in service network 551, e.g. router 541 in FIG. 5. At step 605, the router compares the source IP address in the packet header to a list of addresses allocated to subscribers of services of a second service provider, e.g. operating service network 552 in FIG. 5. If the source IP address matches one of these addresses, then at step 606 the router forwards the

packet to a router in service network 552, e.g. router 542 in FIG. 5. At step 607, the router compares the source IP address in the packet header to a list of addresses allocated to subscribers of services of a third service provider, e.g. operating service network 553 in FIG. 5, which is not connected to this particular managed access point. If the source IP address matches one of these addresses, then at step 608, the router encapsulates the packet, using any of a number of known methods for packet encapsulation, and routes the packet to a new destination address, namely the address of the managed access point with access to service network 553, i.e. managed access point router 574. Packet encapsulation is a method by which a packet may rerouted to an intermediate destination other than the destination that would be selected using normal routing procedures. See, e.g., C. Perkins, “IP Encapsulation within IP,” IETF Network Working Group, RFC 2003 (October 1996); C. Perkins, “Minimal Encapsulation within IP,” IETF Network Working Group, RFC 2004 (October 1996), which are incorporated by reference herein. The receiving router 574 will decapsulate the packet and route the packet, accordingly, to service network 553. The router continues in this fashion with any other packet filtering rules identifying IP addresses associated with any other service providers. Assuming the IP source address does not match any addresses associated with any other service providers, at step 609, the router applies any remaining packet filtering rules and routes or denies the packet accordingly. Note that if managed access point 575 has a direct physical connection to managed access point 574, then no encapsulation is needed. In fact, a typical configuration might include multiple port-constrained policy routers on a GIG Ethernet providing the logical managed access point function without any encapsulation. Encapsulation is only really needed to provide a logical direct connection if there is not a direct physical connection.

[0032] Packets traveling between network access devices connected to the same access network infrastructure can be forwarded directly between the devices in the access network—rather than forwarding the packets outwards to a service network and back to the same access network. This advantageously saves on bandwidth and other network resources. The only packets that need be routed to a managed access point router need be the ones for which no specific route is known internally to the access network infrastructure.

[0033] It is advantageous to enable the IP addresses—which ultimately determine the service network utilized by the particular network access device—to be allocated and reassigned dynamically. With reference to FIG. 1, a service activation system 160 is shown which further comprises a configuration server 161 and a registration server 162 connected to the access network infrastructure 120. The registration server 162 provides a network-based subscription/authorization process for the various services shared on the access network infrastructure 120. A customer desiring to subscribe to a new service can access and provide registration information to the registration server 162, e.g. by using HTML forms and the Hyper Text Transfer Protocol (HTTP) as is known in the art. Upon successful service subscription, the registration server 162 updates a customer registration database 163. The configuration server 161 uses the registration information to activate the service. The configuration server 161 is responsible for allocating network addresses on

behalf of the service networks from a network address space associated with the selected service. In a preferred embodiment of this aspect of the invention, the configuration server 161 uses a host configuration protocol such as the Dynamic Host Configuration Protocol (DHCP) to configure the network addresses of the network access devices. See R. Droms, "Dynamic Host Configuration Protocol," IETF Network Working Group, RFC 2131 (March 1997); S. Alexander, R. Droms, "DHCP Options and BOOTP Vendor Extensions," IETF Network Working Group, RFC 2132 (March 1997); which are incorporated by reference herein. This aspect of the invention shall be described herein with particular reference to DHCP, and the configuration server 161 shall be referred to herein as the DHCP server, although those skilled in the art would readily be able to implement this aspect of the invention using a different protocol.

[0034] FIG. 7 is a simplified timeline diagram of DHCP messages exchanged as the DHCP server 720 assigns a service-specific network address to a network access device 710 acting as a DHCP client. At 701, the network access device 710 sends a DHCPDISCOVER message through the access network infrastructure. The DHCPDISCOVER message, in accordance with an aspect of the invention, includes a "svc-id" option field that identifies the service to which the network access device has been subscribed and from which service is desired. The DHCP server 720 receives the DHCPDISCOVER message and, at 702, allocates an IP address from the pool of addresses associated with the particular service. The DHCP server 720 can use the device's MAC address to lookup the customer's registration information and confirm that the device is authorized to access the identified service. Where the DHCP server 720 cannot find the device's MAC address in the registration database, the server can allocate a special IP address that only allows access to the registration server. At 703, the DHCP server 720 responds with a DHCPOFFER message that includes the IP address in a field in the DHCP message. At 704, the network access device 710 receives the DHCPOFFER (and any other offers from any other DHCP servers in the access network) and sends out a DHCPREQUEST directed to the DHCP server which requests the IP address identified in the DHCPOFFER. At 707, the DHCP server commits to assigning the IP address to the network access device, commits the binding to persistent storage, and transmits a DHCPACK message containing the configuration parameters for the device. If the DHCP server is unable to satisfy the DHCPREQUEST message, the server responds with a DHCPNAK message. FIG. 8 is a simplified representation of the fields in a DHCP message, including a "svc-id" option field (820) which identifies the selected service.

[0035] It is preferable that the DHCP servers and clients use some mutual authentication mechanism to restrict address assignment to authorized hosts and to prevent clients from accepting addresses from invalid DHCP servers. See, for example, the "delayed authentication" scheme described in R. Droms, W. Arbaugh, "Authentication for DHCP Messages," IETF Network Working Group, Internet Draft, <draft-ietf-dhc-authentication-.txt>; or the Kerberos-based authentication mechanism described in K. Hornstein, T. Lemon, B. Aboba, J. Trostle, "DHCP Authentication via Kerberos V," IETF Network Working Group, Internet Draft, <draft-hornstein-dhc-kerbauth-\_.>; which are incorporated by reference herein. The "delayed authentication" mechanism

supports mutual authentication of DHCP clients and servers based on a shared secret, which may be provisioned using out-of-band mechanisms. On the other hand, the Kerberos-based mechanisms are very well suited for inter-realm authentication, thereby supporting client mobility, i.e. a network access device could connect to a particular access network infrastructure without any prior registration with the access network. Each service network provider could securely authenticate the network access device accessing the service network from another network "realm," e.g. the access network infrastructure.

[0036] The operator of the relevant service network, e.g. service network 152 in FIG. 1, may desire to maintain a separate registration server, e.g. server 155 in FIG. 1, and to retain responsibility for user authentication and authorization. The service activation system 160 can provide a proxy server configured to permits HTTP traffic only between local hosts and registration server 155 in service network 152. The service provider operating service network 152 would then be responsible for providing the appropriate registration information required for proper service selection to the service activation system 160. The service provider would also be responsible for notifying the service activation system 160 when service should be discontinued. Alternatively, the DHCP server 161 in the service activation system 160 can interact with the registration server 155 using a back-end authentication protocol, e.g. the Remote Authentication Dial In User Service (RADIUS). See C. Rigney, A. Rubens, W. Simpson, S. Willens, "Remote Authentication Dial In User Service (RADIUS)," IETF Network Working Group, RFC 2058 (January 1997), which is incorporated by reference herein. The DHCP server can contain a RADIUS client and, thereby, leverage the large RADIUS embedded base used for dial access authentication. FIG. 9 illustrates this embodiment of this aspect of the invention in a flowchart corresponding to the flowchart shown in FIG. 7. At 903, the DHCP server 920 generates a random challenge and includes the challenge along with the allocated IP address in the DHCPOFFER message. The DHCP client 910 generates a response to the challenge by encrypting the challenge with a key that is derived from the subscriber's authentication information. At 904, the client 910 includes the challenge, response, and IP address in the DHCPREQUEST message. The DHCP server 920 forwards both the challenge and response in a RADIUS\_ACCESS\_REQ message to a RADIUS server 930 in the selected service network. The RADIUS server 930 either accepts or rejects the RADIUS request and responds accordingly at 906. If the RADIUS request is accepted, the DHCP server 920 sends a DHCPACK message at 907 and the client 910 enters a bound state. If the RADIUS request is rejected, the DHCP server 920 sends a DHCPNAK message which informs the client 910 that the IP address that was allocated has been withdrawn.

[0037] Rather than modifying the DHCP protocol in order to establish the association between the device's MAC address and the service selection, it is advantageous to use an alternative two-step process. The registration server 162 can associate the customer's IP address (used for registration) with the subscribed service, while the configuration server 161 can associate the customer's IP address with the customer's MAC address. The servers can interact and share their associations in the registration database 163 shown in FIG. 1. Thus, the subscriber can register the service selec-

tion with the registration server which temporarily establishes the association between the network access device's hardware address (e.g. the MAC address of the device) and the chosen service selection. The configuration server then uses the MAC address of the network access device to assign an IP address from the proper address space. FIG. 10 is a simplified timeline diagram of DHCP messages exchanged, in accordance with such an embodiment. At 1001, the network access device 1010 registers a service selection with the registration server 1030. It is assumed that the subscriber has passed the proper authentication procedures for the particular service selected, either beforehand (e.g. through transactions directly with the service provider's network) or in the same session with the registration server. The registration server 1030 sends some acknowledgment 1002 to the network access device 1010. At 1003, the registration server 1030 stores the selected service and associates the service selection with the hardware device address (e.g. MAC address) of the network access device 1010. After receiving the acknowledgment from the registration server 1030, the network access device 1010 releases any pre-existing address assignment by issuing a DHCPRELEASE message at 1004. At 1005, the network access device issues a standard DHCPDISCOVER message (i.e., there is no need for the service selection id in the message set forth above). The DHCP server 1020 receives the DHCPDISCOVER message and, at 1006, allocates an IP address from the pool of address associated with the particular service associated with the device's hardware address. At 1007, the DHCP server 1020 sends a DHCP OFFER message that includes the IP address in a field in the DHCP message. At 1008, the network access device 1010 receives the DHCP OFFER and sends out a DHCPREQUEST back to the DHCP server 1030. At 1009, the DHCP server 1030 commits to assigning the IP address to the network access device 1010, commits the binding to persistent storage, and transmits a DHCPACK message containing the configuration parameters for the device.

[0038] It is desirable to restrict access to the access network infrastructure to those network access devices that are properly registered and authenticated. In accordance with another aspect of the invention, the access network infrastructure can be configured to perform access control taking advantage of the above-described address allocation process. An access network infrastructure with broadcast capabilities will often use a protocol such as the Address Resolution Protocol (ARP) to map network layer addresses used by the packet-switched networks to the hardware addresses used in the datalink layer of the access network infrastructure. See, e.g., D. Plummer, "An Ethernet Address Resolution Protocol," IETF Network Working Group, RFC 826 (November 1982). For example, and with reference to the HFC embodiment shown in FIG. 2, the CMTS 225 has an ARP cache, which is a table of entries storing bindings between IP addresses and the hardware MAC addresses assigned to network access devices 201, 202. The ARP cache permits the CMTS to learn the correspondence between IP addresses and MAC addresses without resorting to broadcasting an ARP request. As is known in the art, the CMTS can act as a DHCP relay agent and use information in DHCP messages to populate its ARP cache. This mechanism, in combination with the DHCP address allocation process described above, can be advantageously utilized to control access to the network.

[0039] With reference to FIG. 7 (and FIG. 9), the CMTS acts as a DHCP relay agent and snoops on DHCP messages exchanged between the host acting as a DHCP client and the DHCP server. At step 707 in FIG. 7 and step 907 in FIG. 9, the DHCP server issues a DHCPACK message with configuration parameters including the committed IP address allocated to the subscriber to the particular service selected, as described above. This only occurs after the proper authentication steps have been performed. FIG. 11 is a flowchart illustrating the processing performed at the CMTS. At step 1101, the CMTS receives the DHCP message and proceeds to snoop on its contents in the process of relaying it to the proper DHCP client at step 1106. At step 1102, the CMTS determines that the DHCP message is a DHCPACK message by examining the options field of the DHCP message. At step 1103, the CMTS proceeds to read the information from the DHCPACK message, in particular the "yiaddr" and "chaddr" fields (fields 805 and 808 in FIG. 8) which indicate the assigned IP address and the hardware MAC address respectively. The CMTS updates the ARP cache to reflect the mapping of IP address to MAC address (and SID) used for communication with the subscriber. Thereafter, the CMTS permits upstream and downstream packets to and from the particular network access device based on the ARP cache entry. Where there has been a failure in authentication, this will result in a failure to update the ARP cache and in a denial of access to the access network infrastructure. The information in the ARP cache entry can also be utilized by the CMTS to monitor attempts to "spoof" the IP address of an authenticated subscriber: e.g., by refusing to forward upstream packets with a source IP address that is not associated with the proper SID or MAC address. The CMTS can set the timeout for the ARP cache entry to the same value as the timeout for the IP address specified in the DHCP exchange. If a customer subsequently releases the IP address by issuing a DHCPRELEASE message (or declines to accept the offered IP address, both at step 1104), the CMTS flushes the corresponding ARP cache entry upon receipt of the DHCP message at step 1105.

[0040] The DHCP server should be configured to ensure that every response that changes an IP address assignment or a lease on a DHCP assignment gets relayed to the CMTS. For example, a network access device using standard DHCP can send a DHCPRENEW message directly to the DHCP server. The DHCP server would respond directly to the client, and the CMTS would not perform a DHCP relay function for these messages. Such direct communication between the DHCP client and server may modify information (e.g. lease time) used by the CMTS to manage the ARP cache. Therefore, it is advantageous to modify the DHCP server so that it will notify the CMTS of any changes to IP address assignment including lease time. This can be accomplished, for example, by sending all responses to the CMTS to relay to the client—rather than sending them directly to the client.

[0041] It is advantageous for the access network infrastructure to support quality-of-support, in particular to differentiate service between subscribers to different services or service providers. For example, with reference to FIG. 1, a subscriber to services offered by a service network 151 could get a higher share of access link capacity in the access network infrastructure than a subscriber to services offered by service network 152. Likewise, the aggregate capacity for subscribers to service network 151 may be different (e.g.

higher) than aggregate capacity for subscribers to service network 152. It is preferable to avoid relying on the network access devices 101 . . . 104 or the network interface units 111 . . . 114 to enforce service policies. Instead, it is advantageous for the access network infrastructure to have a policy engine, referred to herein as a policy decision point, and points at which policies may be enforced. The policy decision point, for example, could be a server in the service activation system 160 in the access network infrastructure with access to the relevant registration information for subscribers. The policy decision preferably should be made at a point at which the association between the service network and the access network has been established, e.g. when the authenticated IP address is provided to the network access device as described above. The service class assignment would reflect the results of negotiation between the entity operating the access network infrastructure and the entity operating the service network.

[0042] FIG. 12, for example, sets forth a timeline diagram of messages exchanged in assigning a service class to a subscriber, in the context of the particular HFC architecture described above. At 1201, the network access device 1210 sends the DHCPREQUEST message to the DHCP server 1250, requesting the service-related IP address identified in a previous DHCP OFFER message. At 1202, the DHCP server 1250 commits to assigning the IP address to the network access device 1210 and transmits a DHCPACK message containing the configuration parameters for the device. At 1203, the DHCP server 1250 sends a message to a Policy Decision Point ("PDP") 1240 authorizing assignment of a particular service class to the subscriber. The PDP 1240 transmits traffic parameters for the authorized service flow to the CMTS 1230, which receives the policy parameters at 1204 and begins the process of Dynamic Service Addition (DSA) in accordance with DOCSIS to schedule the service flow. A service flow, as defined by DOCSIS, is a unidirectional flow of packets that is provided a particular quality of service. At 1205, the CMTS 1230 sends a dynamic service addition request (DSA-REQ) message to the cable modem 1220 attached to the relevant network access device 1210. At 1206, the cable modem 1220 sends a dynamic service addition response (DSA-RSP) message after confirming that the cable modem 1220 can support the service flow. At 1207, the CMTS 1230 sends a dynamic service addition acknowledge (DSA-ACK) message after enabling transmission and reception of data on the new service flow. At 1208, the service flow has been allocated, and transmission on the new service flow has been enabled. At 1209, the network access device 1210 can begin transmitting data upstream to the CMTS 1230 which, as described above, forwards the data to the relevant packet-switched network.

[0043] Where the packet-switched network also provides for differentiation in service, e.g. based on the "DiffServ" framework, the cable modem 1220 can mark the Type Of Service (TOS) field of the packet to indicate the service class for the packet. See K. Nichols, S. Blake, F. Baker, D. Black, "Definition of the Differentiated Services Field (DS Field) in the IPv4 and IPv6 Headers," IETF Network Working Group, RFC 2474 (December 1998); S. Blake, D. Black, M. Carlson, E. Davies, Z. Wang, W. Weiss, "An Architecture for Differentiated Services," IETF Network Working Group, RFC 2475 (December 1998), which are incorporated by reference herein. Using the policy information received from the PDP 1240, the CMTS 1230 can act as a policy

enforcement point and police the packets received from the cable modem 1220 and remark the TOS field of the packet where there is any deviation from the policy specified for the particular subscriber. Similarly, the CMTS 1230 can police service flows in the downstream direction, again based on the policy provided by the PDP 1240.

[0044] The CMTS 1230 performs scheduling based on the policies provided by the PDP 1240. Scheduling can be based on differentiation between subscribers to different services or service providers and can also be used to ensure that reserved minimum traffic rate requirements are met (this may require some measurement of capacity allocated to different subscribers as well as an accounting of bandwidth usage). One method of scheduling in the CMTS is to follow class based queuing (CBQ). See S. Floyd, V. Jacobson, "Link-Sharing and Resource Management Models for Packet Networks," IEEE/ACM Transactions on Networking, Vol. 3, No. 4, August 1995, which is incorporated by reference herein. CBQ allows for support of quality-of-support and flexible link sharing. The mechanism can be used to share capacity of a link across services, protocol families and/or traffic types. It can be used to allocate "shares" to individual service providers and subdivide the share amongst the subscribers of a given service provider. For example, arriving packet flows are aggregated into classes, each class having a "priority" and a throughput allocation. The traditional method is to use the information in the packet header, although it is possible, in the HFC architecture, to classify based on SID and the policy set up at the time the service flow is setup. A hierarchy of classes is constructed, e.g. as depicted in FIG. 13. The access link 1300 is shared between three service providers 1351, 1352, and 1353. Each service provider shares its allocation of link bandwidth among its customers, i.e., 1311, 1312, 1313 being subscribers of service provider 1351; 1321, 1322 being subscribers of 1352; 1331 being a subscriber of service provider 1353. The link scheduler may associate weights for each service provider. The service provider "weight" determines the overall share of access link bandwidth to all subscribers of the service provider, when the link is fully utilized. The link scheduler further allocates weights to each customer of the service provider—the customer's weight determining the share of the service provider's link bandwidth available to the subscriber. It can then be possible to "borrow" bandwidth from other service provider subscribers when the service provider's share is not fully subscribed, as well as from other service providers when the link is not fully loaded. It is advantageous for the scheduling to provide such flexible sharing. When the link is underloaded, there is no need for any regulation of access to the HFC link by active SIDs. The scheduler can regulate a particular customer, e.g. by postponing giving grants to a SID of the customer, only when the customer is over the limit in terms of bandwidth share during the short-term interval.

[0045] The foregoing Detailed Description is to be understood as being in every respect illustrative and exemplary, but not restrictive, and the scope of the invention disclosed herein is not to be determined from the Detailed Description, but rather from the claims as interpreted according to the full breadth permitted by the patent laws. It is to be understood that the embodiments shown and described herein are only illustrative of the principles of the present invention and that various modifications may be implemented by those skilled in the art without departing from the scope and spirit of the

invention. For example, the detailed description describes an embodiment of the invention with particular reference to an HFC access network architecture. However, the principles of the present invention could be readily extended to other access network architectures, such as DSL, wireless, satellite, etc. Such an extension could be readily implemented by one of ordinary skill in the art given the above disclosure.

What is claimed is:

1. A method of operating an access network infrastructure in connection with a plurality of service networks comprising the steps of:

creating a service policy message specifying a service class for communications with a network access device after notification that a network address, associated with a service network, has been allocated to the network access device;

transmitting the service policy message to a service policy enforcement point in the access network infrastructure.

2. The invention of claim 1 wherein the service policy enforcement point schedules access to the access network infrastructure based on the service class specified in the service policy message.

3. The invention of claim 2 wherein the service policy enforcement point schedules access using class based queuing.

4. The invention of claim 2 wherein the service policy enforcement point polices access to the access network infrastructure based on the service class specified in the service policy message.

5. The invention of claim 1 wherein the access network infrastructure comprises a hybrid fiber coaxial network.

6. The invention of claim 5 wherein the service policy enforcement point is a cable modem termination system.

7. The invention of claim 1 wherein the service networks utilize the Internet Protocol and wherein the addresses are Internet Protocol addresses.

8. The invention of claim 7 wherein the plurality of service networks are operated by different Internet Service Providers.

9. The invention of claim 7 wherein the plurality of service networks offer access to different Internet Protocol-based services.

10. The invention of claim 1 wherein the network address is allocated using a host configuration protocol.

11. The invention of claim 10 wherein the host configuration protocol is DHCP.

\* \* \* \* \*