

(19) World Intellectual Property Organization
International Bureau



(43) International Publication Date
1 February 2007 (01.02.2007)

PCT

(10) International Publication Number
WO 2007/013915 A1

(51) International Patent Classification:

G01N 27/49 (2006.01) C12Q 1/00 (2006.01)
G01N 33/487 (2006.01) A61B 5/00 (2006.01)

(74) Agent: GATZ, John, C.; Jenkens & Gilchrist, a Professional Corporation, 225 W. Washington Street, Suite 2600, Chicago, Illinois 60606-3418, (US).

(21) International Application Number:

PCT/US2006/028013

(81) Designated States (unless otherwise indicated, for every kind of national protection available): AE, AG, AL, AM, AT, AU, AZ, BA, BB, BG, BR, BW, BY, BZ, CA, CH, CN, CO, CR, CU, CZ, DE, DK, DM, DZ, EC, EE, EG, ES, FI, GB, GD, GE, GH, GM, HN, HR, HU, ID, IL, IN, IS, JP, KE, KG, KM, KN, KP, KR, KZ, LA, LC, LK, LR, LS, LT, LU, LV, LY, MA, MD, MG, MK, MN, MW, MX, MZ, NA, NG, NI, NO, NZ, OM, PG, PH, PL, PT, RO, RS, RU, SC, SD, SE, SG, SK, SL, SM, SY, TJ, TM, TN, TR, TT, TZ, UA, UG, US, UZ, VC, VN, ZA, ZM, ZW.

(22) International Filing Date: 19 July 2006 (19.07.2006)

(25) Filing Language: English

(26) Publication Language: English

(30) Priority Data:

60/700,787 20 July 2005 (20.07.2005) US
60/746,771 8 May 2006 (08.05.2006) US

(84) Designated States (unless otherwise indicated, for every kind of regional protection available): ARIPO (BW, GH, GM, KE, LS, MW, MZ, NA, SD, SL, SZ, TZ, UG, ZM, ZW), Eurasian (AM, AZ, BY, KG, KZ, MD, RU, TJ, TM), European (AT, BE, BG, CH, CY, CZ, DE, DK, EE, ES, FI, FR, GB, GR, HU, IE, IS, IT, LT, LU, LV, MC, NL, PL, PT, RO, SE, SI, SK, TR), OAPI (BF, BJ, CF, CG, CI, CM, GA, GN, GQ, GW, ML, MR, NE, SN, TD, TG).

(71) Applicant (for all designated States except US): BAYER HEALTHCARE LLC [US/US]; 555 White Plains Road, Tarrytown, New York 10591 (US).

(72) Inventors; and

(75) Inventors/Applicants (for US only): WU, Huan-Ping [US/US]; 14374 Shoreline Drive, Granger, Indiana 46530 (US). NELSON, Christine, D. [US/US]; 68972 Lake Street, Edwardsburg, Indiana 49112 (US). BEER, Greg, P. [US/US]; 61684 Parkshore Drive, Cassopolis, Michigan 49031 (US).

Published:

- with international search report
- before the expiration of the time limit for amending the claims and to be republished in the event of receipt of amendments

[Continued on next page]

(54) Title: GATED AMPEROMETRY

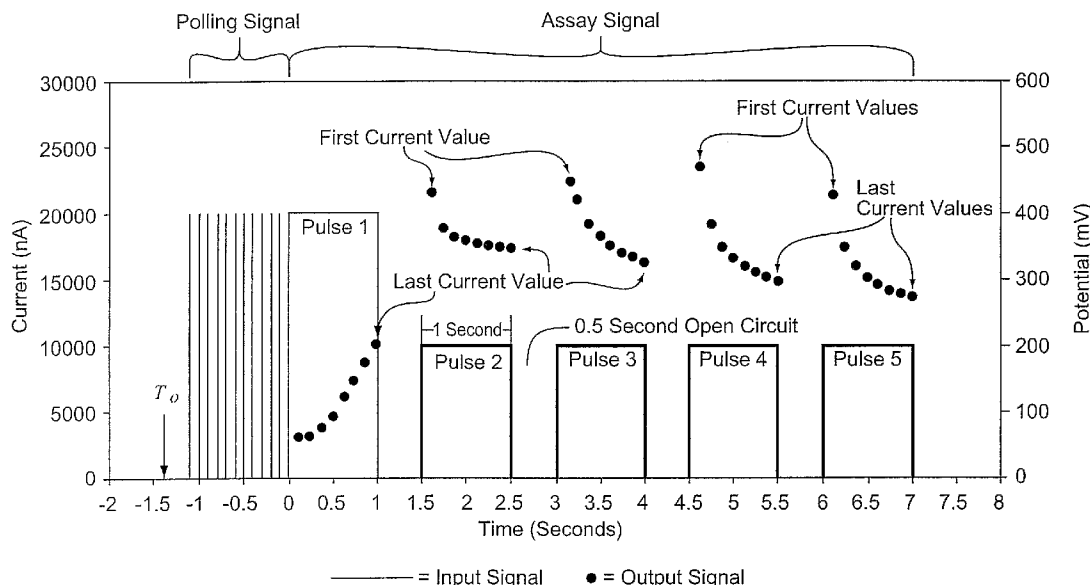

(57) Abstract: A sensor system, device, and methods for determining the concentration of an analyte in a sample is described. Gated amperometric pulse sequences including multiple duty cycles of sequential excitations and relaxations may provide a shorter analysis time and/or improve the accuracy and/or precision of the analysis. The disclosed gated amperometric pulse sequences may reduce analysis errors arising from the hematocrit effect, variance in cap-gap volumes, non-steady-state conditions, mediator background, under-fill, temperature changes in the sample, and a single set of calibration constants.

WO 2007/013915 A1



For two-letter codes and other abbreviations, refer to the "Guidance Notes on Codes and Abbreviations" appearing at the beginning of each regular issue of the PCT Gazette.

GATED AMPEROMETRY

REFERENCE TO RELATED APPLICATIONS

[001] This application claims the benefit of U.S. Provisional Application No. 60/700,787 entitled "Gated Amperometry" as filed on July 20, 2005, and U.S. Provisional Application No. 60/746,771 entitled "Abnormal Output Detection System for a Biosensor" as filed on May 8, 2006, which are incorporated herein by reference.

BACKGROUND

[002] The quantitative determination of analytes in biological fluids is useful in the diagnosis and treatment of physiological abnormalities. For example, determining the glucose level in biological fluids, such as blood, is important to diabetic individuals who must frequently check their blood glucose level to regulate their diets and/or medication.

[003] Electrochemical systems have been used for this type of analysis. During the analysis, the analyte undergoes a redox reaction with an enzyme or similar species to generate an electric current that may be measured and correlated with the concentration of the analyte. A substantial benefit may be provided to the user by decreasing the time required for the analysis while supplying the desired accuracy and precision.

[004] One example of an electrochemical sensor system for analyzing analytes in biological fluids includes a measuring device and a sensor strip. The sensor strip includes reagents to react with and transfer electrons from the analyte during the analysis and electrodes to pass the electrons through conductors that connect the strip with the device. The measuring device includes contacts to receive the electrons from the strip and the ability to apply a voltage differential between the contacts. The device may record the current passing through the sensor and translate the current values into a measure of the analyte content of the sample. These sensor systems may analyze a single drop of whole blood (WB), such as from 1-15 microliters (μL) in volume.

[005] Examples of bench-top measuring devices include the BAS 100B Analyzer available from BAS Instruments in West Lafayette, Indiana; the CH Instrument Analyzer available from CH Instruments in Austin, Texas; the Cypress Electrochemical Workstation available from Cypress Systems in Lawrence, Kansas; and the EG&G Electrochemical Instrument available from Princeton Research Instruments in Princeton, New Jersey.

Examples of portable measuring devices include the Ascensia Breeze® and Elite® meters of Bayer Corporation.

[006] The sensor strip may include a working electrode where the analyte undergoes electrochemical reaction and a counter electrode where the opposite electrochemical reaction occurs, thus allowing current to flow between the electrodes. Thus, if oxidation occurs at the working electrode, reduction occurs at the counter electrode. See, for example, *Fundamentals Of Analytical Chemistry*, 4th Edition, D.A. Skoog and D.M. West; Philadelphia: Saunders College Publishing (1982), pp 304-341.

[007] The sensor strip also may include a true reference electrode to provide a non-variant reference potential to the measuring device. While multiple reference electrode materials are known, a mixture of silver (Ag) and silver chloride (AgCl) is typical due to the insolubility of the mixture in the aqueous environment of the analysis solution. A reference electrode also may be used as the counter electrode. A sensor strip using such a combination reference-counter electrode is described in U.S. Patent No. 5,820,551.

[008] The sensor strip may be formed by printing electrodes on an insulating substrate using multiple techniques, such as those described in U.S. Patent Nos. 6,531,040; 5,798,031; and 5,120,420. One or more reagent layer may be formed by coating one or more of the electrodes, such as the working and/or counter electrodes. In one aspect, more than one of the electrodes may be covered by the same reagent layer, such as when the working and counter electrodes are coated by the same composition. In another aspect, reagent layers having different compositions may be printed or micro-deposited onto the working and counter electrodes using the method described in a U.S. provisional patent application filed October 24, 2003, Application No. 60/513,817. Thus, the reagent layer on the working electrode may contain the enzyme, the mediator, and a binder while the reagent layer on the counter electrode contains a soluble redox species, which could be the same as the mediator or different, and a binder.

[009] The reagent layer may include an ionizing agent for facilitating the oxidation or reduction of the analyte, as well as any mediators or other substances that assist in transferring electrons between the analyte and the conductor. The ionizing agent may be an analyte specific enzyme, such as glucose oxidase or glucose dehydrogenase, to catalyze the oxidation of glucose in a whole blood (WB) sample. The reagent layer also may include a binder that holds the enzyme and mediator together. Table I, below, provides conventional combinations of enzymes and mediators for use with specific analytes.

Analyte	Enzyme	Mediator
Glucose	Glucose Oxidase	Ferricyanide
Glucose	Glucose Dehydrogenase	Ferricyanide
Cholesterol	Cholesterol Oxidase	Ferricyanide
Lactate	Lactate Oxidase	Ferricyanide
Uric Acid	Uricase	Ferricyanide
Alcohol	Alcohol Oxidase	Phenylenediamine

Table I

[0010] The binder may include various types and molecular weights of polymers, such as CMC (carboxyl methyl cellulose) and/or PEO (polyethylene oxide). In addition to binding the reagents together, the binder may assist in filtering red blood cells, preventing them from coating the electrode surface.

[0011] Examples of conventional electrochemical sensor systems for analyzing analytes in biological fluids include the Precision® biosensors available from Abbott in Abbott Park, Illinois; Accucheck® biosensors available from Roche in Indianapolis, Indiana; and OneTouch Ultra® biosensors available from Lifescan in Milpitas, California.

[0012] One electrochemical method, which has been used to quantify analytes in biological fluids, is coulometry. For example, Heller et al. described the coulometric method for whole blood glucose measurements in U.S. Patent No. 6,120,676. In coulometry, the analyte concentration is quantified by exhaustively oxidizing the analyte within a small volume and integrating the current over the time of oxidation to produce the electrical charge representing the analyte concentration. In other words, coulometry captures the total amount of glucose within the sensor strip.

[0013] An important aspect of coulometry is that towards the end of the integration curve of charge vs. time, the rate at which the current changes with time becomes substantially constant to yield a steady-state condition. This steady-state portion of the coulometric curve forms a relatively flat plateau region, thus allowing determination of the corresponding current. However, the coulometric method requires the complete conversion of the entire volume of analyte to reach the steady-state condition. As a result, this method is time consuming and does not provide the fast results which users of electrochemical devices, such as glucose-monitoring products, demand. Another problem with coulometry is that the small volume of the sensor cell must be controlled in order to provide accurate results, which can be difficult with a mass produced device.

[0014] Another electrochemical method which has been used to quantify analytes in biological fluids is amperometry. In amperometry, current is measured during a read pulse as a constant potential (voltage) is applied across the working and counter electrodes of the sensor strip. The measured current is used to quantify the analyte in the sample. Amperometry measures the rate at which the electrochemically active species, and thus the analyte, is being oxidized or reduced near the working electrode. Many variations of the amperometric method for biosensors have been described, for example in U.S. Patent Nos. 5,620,579; 5,653,863; 6,153,069; and 6,413,411.

[0015] A disadvantage of conventional amperometric methods is the non-steady-state nature of the current after a potential is applied. The rate of current change with respect to time is very fast initially and becomes slower as the analysis proceeds due to the changing nature of the underlying diffusion process. Until the consumption rate of the reduced mediator at the electrode surface equals the diffusion rate, a steady-state current cannot be obtained. Thus, for amperometry methods, measuring the current during the transient period before a steady-state condition is reached may be associated with more inaccuracy than a measurement taken during a steady-state time period.

[0016] The "hematocrit effect" provides an impediment to accurately analyzing the concentration of glucose in WB samples. WB samples contain red blood (RB) cells and plasma. The plasma is mostly water, but contains some proteins and glucose. Hematocrit is the volume of the RB cell constituent in relation to the total volume of the WB sample and is often expressed as a percentage. Whole blood samples generally have hematocrit percentages ranging from 20% to 60%, with ~40% being the average.

[0017] In conventional sensor strips for determining glucose concentrations, glucose may be oxidized by an enzyme, which then transfers the electron to a mediator. This reduced mediator then travels to the working electrode where it is electrochemically oxidized. The amount of mediator being oxidized may be correlated to the current flowing between the working and counter electrodes of the sensor strip. Quantitatively, the current measured at the working electrode is directly proportional to the diffusion coefficient of the mediator. The hematocrit effect interferes with this process because the RB cells block the diffusion of the mediator to the working electrode. Subsequently, the hematocrit effect influences the amount of current measured at the working electrode without any connection to the amount of glucose in the sample.

[0018] WB samples having varying concentrations of RB cells may cause inaccuracies in the measurement because the sensor may not distinguish between a lower mediator concentration and a higher mediator concentration where the RB cells block diffusion to the working electrode. For example, when WB samples containing identical glucose levels, but having hematocrits of 20, 40, and 60%, are analyzed, three different glucose readings will be reported by a conventional sensor system based on one set of calibration constants (slope and intercept, for instance). Even though the glucose concentrations are the same, the system will report that the 20% hematocrit sample contains more glucose than the 60% hematocrit sample due to the RB cells interfering with diffusion of the mediator to the working electrode.

[0019] The normal hematocrit range (RBC concentration) for humans is from 20% to 60% and is centered around 40%. Hematocrit bias refers to the difference between the reference glucose concentration obtained with a reference instrument, such as the YSI 2300 STAT PLUS™ available from YSI Inc., Yellow Springs, Ohio, and an experimental glucose reading obtained from a portable sensor system for samples containing differing hematocrit levels. The difference between the reference and experimental readings results from the varying hematocrit levels between specific whole blood samples.

[0020] In addition to the hematocrit effect, measurement inaccuracies also may arise when the measurable species concentration does not correlate with the analyte concentration. For example, when a sensor system determines the concentration of a reduced mediator generated in response to the oxidation of an analyte, any reduced mediator not generated by oxidation of the analyte will lead to the sensor system indicating that more analyte is present in the sample than is correct due to mediator background.

[0021] In addition to the hematocrit and mediator background effects, other factors also may lead to inaccuracies in the ability of a conventional electrochemical sensor system to determine the concentration of an analyte in a sample. In one aspect, these inaccuracies may be introduced because the portion of the sensor strip that contains the sample may vary in volume from strip to strip. Inaccuracies also may be introduced when sufficient sample is not provided to completely fill the volume of the cap-gap, a condition referred to as under-fill. In other aspects, inaccuracies may be introduced into the measurement by random "noise" and when the sensor system lacks the ability to accurately determine temperature changes in the sample.

[0022] In an attempt to overcome one or more of these disadvantages, conventional sensor systems have attempted multiple techniques, not only with regard to the mechanical design of the sensor strip and reagent selection, but also regarding the manner in which the measuring device applies the electric potential to the strip. For example, conventional methods of reducing the hematocrit effect for amperometric sensors include the use of filters, as disclosed in U.S. Patent Nos. 5,708,247 and 5,951,836; reversing the polarity of the applied current, as disclosed in WO 01/57510; and by methods that maximize the inherent resistance of the sample, as disclosed in U.S. Patent No. 5,628,890.

[0023] Multiple methods of applying the electric potential to the strip, commonly referred to as pulse methods, sequences, or cycles, have been used to address inaccuracies in the determined analyte concentration. For example, in U.S. Patent No. 4,897,162 the pulse method includes a continuous application of rising and falling voltage potentials that are commingled to give a triangular-shaped wave. Furthermore, WO 2004/053476 and U.S. Publication Nos. 2003/0178322 and 2003/0113933 describe pulse methods that include the continuous application of rising and falling voltage potentials that also change polarity.

[0024] Other conventional methods combine a specific electrode configuration with a pulse sequence adapted to that configuration. For example, U.S. Patent No. 5,942,102 combines the specific electrode configuration provided by a thin layer cell with a continuous pulse so that the reaction products from the counter electrode arrive at the working electrode. This combination is used to drive the reaction until the current change verses time becomes constant, thus reaching a true steady state condition for the mediator moving between the working and counter electrodes during the potential step. While each of these methods balances various advantages and disadvantages, none are ideal.

[0025] As may be seen from the above description, there is an ongoing need for improved electrochemical sensor systems, especially those that may provide increasingly accurate determination of the analyte concentration in less time. The systems, devices, and methods of the present invention overcome at least one of the disadvantages associated with conventional systems.

SUMMARY

[0026] A method of determining the concentration of an analyte in a sample is provided that includes applying a pulse sequence to the sample, the pulse sequence including at least 3 duty cycles within 180 seconds. The duty cycles may each include an excitation at

a fixed potential, during which a current may be recorded, and a relaxation. The pulse sequence may include a terminal read pulse and may be applied to a sensor strip including a diffusion barrier layer (DBL) on a working electrode. The determined analyte concentration may include less bias attributable to mediator background than the same or another method lacking the pulse sequence including at least 3 duty cycles within 180 seconds. Through the use of transient current data, the concentration of the analyte may be determined when a steady-state condition is not reached during the excitation portions of the duty cycles of the pulse sequence. A data treatment may be applied to the measured currents to determine the concentration of the analyte in the sample.

[0027] A handheld analyte measuring device is provided for determining the concentration of an analyte in a sample. The device includes a gated amperometric measuring device adapted to receive a sensor strip. The gated amperometric measuring device includes at least two device contacts in electrical communication with a display through electrical circuitry. The sensor strip includes at least first and second sensor strip contacts. The first sensor strip contact is in electrical communication with a working electrode and the second sensor strip contact is in electrical communication with a counter electrode through conductors. A first reagent layer is on at least one of the electrodes and includes an oxidoreductase and at least one species of a redox pair.

[0028] A handheld measuring device adapted to receive a sensor strip is provided for determining the concentration of an analyte in a sample. The device includes contacts, at least one display, and electronic circuitry establishing electrical communication between the contacts and the display. The circuitry includes an electric charger and a processor, where the processor is in electrical communication with a computer readable storage medium. The medium includes computer readable software code, which when executed by the processor, causes the charger to implement a pulse sequence comprising at least 3 duty cycles within 180 seconds between the contacts.

[0029] A method of reducing the bias attributable to mediator background in a determined concentration of an analyte in a sample is provided that includes applying a pulse sequence including at least 3 duty cycles within 180 seconds to the sample.

[0030] A method of determining the duration of a pulse sequence including at least 3 duty cycles within 180 seconds, for determining the concentration of an analyte in a sample is provided that includes determining a plurality of sets of calibration constants determined

from currents recorded during the at least 3 duty cycles and determining the duration of the pulse sequence in response to the determined concentration of the analyte in the sample.

[0031] A method of signaling a user to add additional sample to a sensor strip is provided that includes determining if the sensor strip is under-filled by determining a decay constant from currents recorded during a gated amperometric pulse sequence and signaling the user to add additional sample to the sensor strip if the strip is under-filled.

[0032] A method of determining the temperature of a sample contained by a sensor strip is provided that includes determining a decay constant from currents recorded during a gated amperometric pulse sequence and correlating the decay constant with a temperature value.

[0033] A method of determining the duration of a pulse sequence for determining the concentration of an analyte in a sample is provided that includes determining the temperature of a sample contained by a sensor strip from decay constants determined from currents recorded during a gated amperometric pulse sequence.

[0034] The following definitions are included to provide a clear and consistent understanding of the specification and claims.

[0035] The term “analyte” is defined as one or more substances present in a sample. The analysis determines the presence and/or concentration of the analyte present in the sample.

[0036] The term “sample” is defined as a composition that may contain an unknown amount of the analyte. Typically, a sample for electrochemical analysis is in liquid form, and preferably the sample is an aqueous mixture. A sample may be a biological sample, such as blood, urine, or saliva. A sample also may be a derivative of a biological sample, such as an extract, a dilution, a filtrate, or a reconstituted precipitate.

[0037] The term “measurable species” is defined as any electrochemically active species that may be oxidized or reduced under an appropriate potential at the working electrode of an electrochemical sensor strip. Examples of measurable species include analytes, oxidoreductases, and mediators.

[0038] The term “amperometry” is defined as an analysis method where the concentration of an analyte in a sample is determined by electrochemically measuring the oxidation or reduction rate of the analyte at a potential.

[0039] The term “system” or “sensor system” is defined as a sensor strip in electrical communication through its conductors with a measuring device, which allows for the quantification of an analyte in a sample.

[0040] The term “sensor strip” is defined as a device that contains the sample during the analysis and provides electrical communication between the sample and the measuring device. The portion of the sensor strip that contains the sample is often referred to as the “cap-gap.”

[0041] The term “conductor” is defined as an electrically conductive substance that remains stationary during an electrochemical analysis.

[0042] The term “measuring device” is defined as one or more electronic devices that may apply an electric potential to the conductors of a sensor strip and measure the resulting current. The measuring device also may include the processing capability to determine the presence and/or concentration of one or more analytes in response to the recorded current values.

[0043] The term “accuracy” is defined as how close the amount of analyte measured by a sensor strip corresponds to the true amount of analyte in the sample. In one aspect, accuracy may be expressed in terms of bias.

[0044] The term “precision” is defined as how close multiple analyte measurements are for the same sample. In one aspect, precision may be expressed in terms of the spread or variance among multiple measurements.

[0045] The term “redox reaction” is defined as a chemical reaction between two species involving the transfer of at least one electron from a first species to a second species. Thus, a redox reaction includes an oxidation and a reduction. The oxidation half-cell of the reaction involves the loss of at least one electron by the first species, while the reduction half-cell involves the addition of at least one electron to the second species. The ionic charge of a species that is oxidized is made more positive by an amount equal to the number of electrons removed. Likewise, the ionic charge of a species that is reduced is made less positive by an amount equal to the number of electrons gained.

[0046] The term “mediator” is defined as a substance that may be oxidized or reduced and that may transfer one or more electrons. A mediator is a reagent in an electrochemical analysis and is not the analyte of interest, but provides for the indirect measurement of the analyte. In a simplistic system, the mediator undergoes a redox reaction in response to the oxidation or reduction of the analyte. The oxidized or reduced mediator then undergoes the

opposite reaction at the working electrode of the sensor strip and is regenerated to its original oxidation number.

[0047] The term “binder” is defined as a material that provides physical support and containment to the reagents while having chemical compatibility with the reagents.

[0048] The term “mediator background” is defined as the bias introduced into the measured analyte concentration attributable to measurable species not responsive to the underlying analyte concentration.

[0049] The term “under-fill” is defined as when insufficient sample was introduced into the sensor strip to obtain an accurate analysis.

[0050] The term “redox pair” is defined as two conjugate species of a chemical substance having different oxidation numbers. Reduction of the species having the higher oxidation number produces the species having the lower oxidation number. Alternatively, oxidation of the species having the lower oxidation number produces the species having the higher oxidation number.

[0051] The term “oxidation number” is defined as the formal ionic charge of a chemical species, such as an atom. A higher oxidation number, such as (III), is more positive, and a lower oxidation number, such as (II), is less positive.

[0052] The term “soluble redox species” is defined as a substance that is capable of undergoing oxidation or reduction and that is soluble in water (pH 7, 25° C) at a level of at least 1.0 grams per Liter. Soluble redox species include electro-active organic molecules, organotransition metal complexes, and transition metal coordination complexes. The term “soluble redox species” excludes elemental metals and lone metal ions, especially those that are insoluble or sparingly soluble in water.

[0053] The term “oxidoreductase” is defined as any enzyme that facilitates the oxidation or reduction of an analyte. An oxidoreductase is a reagent. The term oxidoreductase includes “oxidases,” which facilitate oxidation reactions where molecular oxygen is the electron acceptor; “reductases,” which facilitate reduction reactions where the analyte is reduced and molecular oxygen is not the analyte; and “dehydrogenases,” which facilitate oxidation reactions where molecular oxygen is not the electron acceptor. *See, for example, Oxford Dictionary of Biochemistry and Molecular Biology, Revised Edition, A.D. Smith, Ed., New York: Oxford University Press (1997) pp. 161, 476, 477, and 560.*

[0054] The term “electro-active organic molecule” is defined as an organic molecule lacking a metal that is capable of undergoing an oxidation or reduction reaction. Electro-active organic molecules may serve as mediators.

[0055] The term “organotransition metal complex,” also referred to as “OTM complex,” is defined as a complex where a transition metal is bonded to at least one carbon atom through a sigma bond (formal charge of -1 on the carbon atom sigma bonded to the transition metal) or a pi bond (formal charge of 0 on the carbon atoms pi bonded to the transition metal). For example, ferrocene is an OTM complex with two cyclopentadienyl (Cp) rings, each bonded through its five carbon atoms to an iron center by two pi bonds and one sigma bond. Another example of an OTM complex is ferricyanide (III) and its reduced ferrocyanide (II) counterpart, where six cyano ligands (formal charge of -1 on each of the 6 ligands) are sigma bonded to an iron center through the carbon atoms.

[0056] The term “coordination complex” is defined as a complex having well-defined coordination geometry, such as octahedral or square planar. Unlike OTM complexes, which are defined by their bonding, coordination complexes are defined by their geometry. Thus, coordination complexes may be OTM complexes (such as the previously mentioned ferricyanide), or complexes where non-metal atoms other than carbon, such as heteroatoms including nitrogen, sulfur, oxygen, and phosphorous, are datively bonded to the transition metal center. For example, ruthenium hexaamine is a coordination complex having a well-defined octahedral geometry where six NH_3 ligands (formal charge of 0 on each of the 6 ligands) are datively bonded to the ruthenium center. A more complete discussion of organotransition metal complexes, coordination complexes, and transition metal bonding may be found in Collman et al., Principles and Applications of Organotransition Metal Chemistry (1987) and Miessler & Tarr, Inorganic Chemistry (1991).

[0057] The term “steady-state” is defined as when the change in electrochemical signal (current) with respect to its independent input variable (voltage or time) is substantially constant, such as within ± 10 or $\pm 5\%$.

[0058] The term “transient point” is defined as the current value obtained as a function of time when an increasing rate of diffusion of a measurable species to a conductor surface transitions into a relatively constant rate of diffusion. Before the transient point, the current is rapidly changing with time. Similarly, after the transient point, the rate of current decay becomes relatively constant, thus reflecting the relatively constant rate of diffusion of a measurable species to a conductor surface.

[0059] The term “relatively constant” is defined as when the change in a current value or a diffusion rate is within ± 20 , ± 10 , or $\pm 5\%$.

[0060] The term “average initial thickness” refers to the average height of a layer prior to the introduction of a liquid sample. The term average is used because the top surface of the layer is uneven, having peaks and valleys.

[0061] The term “redox intensity” (RI) is defined as the total excitation time divided by the sum of the total excitation time and the total relaxation time delays for a pulse sequence.

[0062] The term “handheld device” is defined as a device that may be held in a human hand and is portable. An example of a handheld device is the measuring device accompanying Ascensia® Elite Blood Glucose Monitoring System, available from Bayer HealthCare, LLC, Tarrytown, New York.

[0063] The term “on” is defined as “above” and is relative to the orientation being described. For example, if a first element is deposited over at least a portion of a second element, the first element is said to be “deposited on” the second. In another example, if a first element is present above at least a portion of a second element, the first element is said to be “on” the second. The use of the term “on” does not exclude the presence of substances between the upper and lower elements being described. For example, a first element may have a coating over its top surface, yet a second element over at least a portion of the first element and its top coating may be described as “on” the first element. Thus, the use of the term “on” may or may not mean that the two elements being related are in physical contact.

BRIEF DESCRIPTION OF THE DRAWINGS

[0064] The invention may be better understood with reference to the following drawings and description. The components in the figures are not necessarily to scale, emphasis instead being placed upon illustrating the principles of the invention. Moreover, in the figures, like referenced numerals designate corresponding parts throughout the different views.

[0065] FIG. 1A is a perspective representation of an assembled sensor strip.

[0066] FIG. 1B is a top-view diagram of a sensor strip, with the lid removed.

[0067] FIG. 2 depicts an end-view diagram of the sensor strip of FIG. 1B.

[0068] FIG. 3 represents an electrochemical analytic method of determining the presence and concentration of an analyte in a sample.

- [0069] FIGs. 4A and 4B depict a working electrode having a surface conductor and a DBL during the application of long and short read pulses.
- [0070] FIGs. 5A-5E represent five examples of pulse sequences where multiple duty cycles were applied to the sensor strip after introduction of the sample.
- [0071] FIG. 6A shows the transient output currents of the pulse sequence represented in FIG. 5B for 40% hematocrit WB samples containing 50, 100, 200, 400, and 600 mg/dL glucose.
- [0072] FIG. 6B shows current contour profiles prepared by plotting and connecting the final current value from each of the transient current profiles shown in FIG. 6A.
- [0073] FIG. 6C shows current contour profiles prepared from transient current profiles generated by the pulse sequence depicted in FIG. 5E.
- [0074] FIG. 6D is a graph illustrating output signals in relation to input signals for an electrochemical system using gated amperometric pulse sequences.
- [0075] FIGs. 7A and 7B are graphs illustrating the improvement in measurement accuracy when a DBL is combined with a short read pulse.
- [0076] FIGs. 7C and 7D are graphs illustrating the reduction in hematocrit bias that may be obtained when a gated amperometric pulse sequence is combined with a DBL.
- [0077] FIG. 8 plots the endpoint currents recorded at multiple duty cycles when the pulse sequence of FIG. 5B was applied to WB samples containing various glucose concentrations.
- [0078] FIG. 9A depicts the transient current profiles obtained from the pulse sequence represented in FIG. 5B when a 2.0 μ L sample was introduced to 10 different sensor strips.
- [0079] FIG. 9B depicts the profiles of the decay rate of each pulse sequence converted from FIG. 9A as a function of time.
- [0080] FIG. 10 plots K constants determined from a pulse sequence for glucose concentrations of 50, 100, and 400 mg/dL as a function of temperature.
- [0081] FIG. 11 is a schematic representation of a measuring device.

DETAILED DESCRIPTION

[0082] The present invention makes use of the discovery that gated amperometric pulse sequences including multiple duty cycles may provide improved accuracy and precision to an analysis, while reducing the completion time of the analysis. Each duty cycle includes an excitation that may be provided at a relatively constant voltage. Each duty cycle also

includes a relaxation that may be provided by an open circuit. The pulse sequences of the present invention may reduce the time required for analysis by eliminating the need for additional delays and pulses, such as “incubation” delays to provide reagent rehydration, “burn-off” pulses to renew the electrodes, and mediator regeneration pulses to renew the oxidation state of the mediator, thus reducing analysis time.

[0083] Even with shorter analysis times, the gated amperometric pulse sequences of the present invention may improve accuracy and/or precision in relation to conventional methods. In one aspect, accuracy errors introduced by the hematocrit effect and precision errors introduced by varying cap-gap volume may be reduced through the combination of a diffusion barrier layer with the pulse sequences of the present invention. In another aspect, errors otherwise resulting from a non-steady-state sensor condition and/or mediator background may be reduced. The gated pulse sequences of the present invention also may allow the determination of transient current and contour profiles that simulate a steady-state condition. The transient current profiles may be used to provide a plurality of sets of calibration constants, under-fill detection, and the ability to determine the temperature of the sample, instead of relying on the temperature from the measuring device.

[0084] FIGs. 1A and 1B depict a sensor strip 100, which may be used in the present invention. FIG. 1A is a perspective representation of an assembled sensor strip 100 including a sensor base 110, at least partially covered by a lid 120 that includes a vent 130, a concave area 140, and an input end opening 150. A partially-enclosed volume 160 (the cap-gap) is formed between the base 110 and the lid 120. Other sensor strip designs compatible with the present invention also may be used, such as those described in U.S. Patent Nos. 5,120,420 and 5,798,031.

[0085] A liquid sample for analysis may be transferred into the cap-gap 160 by introducing the liquid to the opening 150. The liquid fills the cap-gap 160 while expelling the previously contained air through the vent 130. The cap-gap 160 may contain a composition (not shown) that assists in retaining the liquid sample in the cap-gap. Examples of such compositions include water-swelling polymers, such as carboxymethyl cellulose and polyethylene glycol; and porous polymer matrices, such as dextran and polyacrylamide.

[0086] FIG. 1B depicts a top-view of the sensor strip 100, with the lid 120 removed. Conductors 170 and 180 may run under a dielectric layer 190 from the opening 150 to a working electrode 175 and a counter electrode 185, respectively. In one aspect, the working and counter electrodes 175, 185 may be in substantially the same plane, as depicted in the

figure. In a related aspect, the working and counter electrodes 175, 185 may be separated by greater than 200 or 250 μm and may be separated from an upper portion of the lid 120 by at least 100 μm . The dielectric layer 190 may partially cover the electrodes 175, 185 and may be made from any suitable dielectric material, such as an insulating polymer.

[0087] The counter electrode 185 balances the potential at the working electrode 175 of the sensor strip 100. In one aspect, this potential may be a reference potential achieved by forming the counter electrode 185 from a redox pair, such as Ag/AgCl, to provide a combined reference-counter electrode. In another aspect, the potential may be provided to the sensor system by forming the counter electrode 185 from an inert material, such as carbon, and including a soluble redox species, such as ferricyanide, within the cap-gap 160. Alternatively, the sensor strip 100 may be provided with a third conductor and electrode (not shown) to provide a reference potential to the sensor system.

[0088] FIG. 2 depicts an end-view diagram of the sensor strip depicted in FIG. 1B showing the layer structure of the working electrode 175 and the counter electrode 185. The conductors 170 and 180 may lie directly on the base 110. Surface conductor layers 270 and 280 optionally may be deposited on the conductors 170 and 180, respectively. The surface conductor layers 270, 280 may be made from the same or from different materials.

[0089] The material or materials used to form the conductors 170, 180 and the surface conductor layers 270, 280 may include any electrical conductor. Preferable electrical conductors are non-ionizing, such that the material does not undergo a net oxidation or a net reduction during analysis of the sample. The conductors 170, 180 preferably include a thin layer of a metal paste or metal, such as gold, silver, platinum, palladium, copper, or tungsten. The surface conductor layers 270, 280 preferably include carbon, gold, platinum, palladium, or combinations thereof. If a surface conductor layer is not present on a conductor, the conductor is preferably made from a non-ionizing material.

[0090] The surface conductor material may be deposited on the conductors 170, 180 by any conventional means compatible with the operation of the sensor strip, including foil deposition, chemical vapor deposition, slurry deposition, and the like. In the case of slurry deposition, the mixture may be applied as an ink to the conductors 170, 180, as described in U.S. Patent No. 5,798,031.

[0091] The reagent layers 275 and 285 may be deposited on the conductors 170 and 180, respectively, and include reagents and optionally a binder. The binder material is preferably a polymeric material that is at least partially water-soluble. Suitable partially

water-soluble polymeric materials for use as the binder may include poly(ethylene oxide) (PEO), carboxy methyl cellulose (CMC), polyvinyl alcohol (PVA), hydroxyethylene cellulose (HEC), hydroxypropyl cellulose (HPC), methyl cellulose, ethyl cellulose, ethyl hydroxyethyl cellulose, carboxymethyl ethyl cellulose, polyvinyl pyrrolidone (PVP), polyamino acids such as polylysine, polystyrene sulfonate, gelatin, acrylic acid, methacrylic acid, starch, maleic anhydride salts thereof, derivatives thereof, and combinations thereof. Among the above binder materials, PEO, PVA, CMC, and PVA are preferred, with CMC and PEO being more preferred at present.

[0092] In addition to the binder, the reagent layers 275 and 285 may include the same or different reagents. In one aspect, the reagents present in the first layer 275 may be selected for use with the working electrode 175, while the reagents present in the second layer 285 may be selected for use with the counter electrode 185. For example, the reagents in the layer 285 may facilitate the free flow of electrons between the sample and the conductor 180. Similarly, the reagents in the layer 275 may facilitate the reaction of the analyte.

[0093] The reagent layer 275 may include an oxidoreductase specific to the analyte that may facilitate the reaction of the analyte while enhancing the specificity of the sensor system to the analyte, especially in complex biological samples. Examples of some specific oxidoreductases and corresponding analytes are given below in Table II.

Oxidoreductase (reagent layer)	Analyte
Glucose dehydrogenase	β -glucose
Glucose oxidase	β -glucose
Cholesterol esterase; cholesterol oxidase	Cholesterol
Lipoprotein lipase; glycerol kinase; glycerol-3-phosphate oxidase	Triglycerides
Lactate oxidase; lactate dehydrogenase; diaphorase	Lactate
Pyruvate oxidase	Pyruvate
Alcohol oxidase	Alcohol
Bilirubin oxidase	Bilirubin
Uricase	Uric acid
Glutathione reductase	NAD(P)H
Carbon monoxide oxidoreductase	Carbon monoxide

Table II

At present, especially preferred oxidoreductases for glucose analysis include glucose oxidase, glucose dehydrogenase, derivatives thereof, or combinations thereof.

[0094] The reagent layer 275 also may include a mediator to more effectively communicate the results of the analyte reaction to the surface conductor 270 and/or the conductor 170. Examples of mediators include OTM complexes, coordination complexes, and electro-active organic molecules. Specific examples include ferrocene compounds, ferrocyanide, ferricyanide, coenzymes of substituted or unsubstituted pyrroloquinoline quinones (PQQ), substituted or unsubstituted 3-phenylimino-3H-phenothiazines (PIPT), 3-phenylimino-3H-phenoxazine (PIPO), substituted or unsubstituted benzoquinones, substituted or unsubstituted naphthoquinones, N oxides, nitroso compounds, hydroxylamines, oxines, flavins, phenazines, phenazine derivatives, phenothiazines, indophenols, and indamines. These, and other mediators that may be included in the reagent layer may be found in U.S. Patent Nos. 5,653,863; 5,520,786; 4,746,607; 3,791,988; and in EP Patent Nos. 0354441 and 0330517.

[0095] At present, especially preferred mediators for glucose analysis include ferricyanide, ruthenium hexaamine, PIPT, PIPO, or combinations thereof. A review of useful electrochemical mediators for biological redox systems may be found in *Analytica Clinica Acta*. 140 (1982), pages 1-18.

[0096] The reagent layers 275, 285 may be deposited by any convenient means, such as printing, liquid deposition, or ink-jet deposition. In one aspect, the layers are deposited by printing. With other factors being equal, the angle of the printing blade may inversely affect the thickness of the reagent layers. For example, when the blade is moved at an approximately 82° angle to the base 110, the layer may have a thickness of approximately 10 μm. Similarly, when a blade angle of approximately 62° to the base 110 is used, a thicker 30 μm layer may be produced. Thus, lower blade angles may provide thicker reagent layers. In addition to blade angle, other factors, such as the viscosity of the material being applied as well as the screen-size and emulsion combination, may affect the resulting thickness of the reagent layers 275, 285.

[0097] The working electrode 175 also may include a diffusion barrier layer (DBL) that is integral to a reagent layer 275 or that is a distinct layer 290, such as depicted in FIG. 2. Thus, the DBL may be formed as a combination reagent/DBL on the conductor, as a distinct layer on the conductor, or as a distinct layer on the reagent layer. When the working electrode 175 includes the distinct DBL 290, the reagent layer 275 may or may not reside on

the DBL 290. Instead of residing on the DBL 290, the reagent layer 275 may reside on any portion of the sensor strip 100 that allows the reagent to solubilize in the sample. For example, the reagent layer 175 may reside on the base 110 or on the lid 120.

[0098] The DBL provides a porous space having an internal volume where a measurable species may reside. The pores of the DBL may be selected so that the measurable species may diffuse into the DBL, while physically larger sample constituents, such as RB cells, are substantially excluded. Although conventional sensor strips have used various materials to filter RB cells from the surface of the working electrode, a DBL provides an internal porous space to contain and isolate a portion of the measurable species from the sample.

[0099] When the reagent layer 275 includes a water-soluble binder, any portion of the binder that does not solubilize into the sample prior to the application of an excitation may function as an integral DBL. The average initial thickness of a combination DBL/reagent layer is preferably less than 30 or 23 micrometers (μm) and more preferably less than 16 μm . At present, an especially preferred average initial thicknesses of a combination DBL/reagent layer is from 1 to 30 μm or from 3 to 12 μm . The desired average initial thickness of a combination DBL/reagent layer may be selected for a specific excitation length on the basis of when the diffusion rate of the measurable species from the DBL to a conductor surface, such as the surface of the conductor 170 or the surface of the surface conductor 270 from FIG. 2, becomes relatively constant.

[00100] Furthermore, using too thick of a DBL with a short excitation length may delay when the diffusion rate of the measurable species from the DBL to the conductor surface becomes relatively constant. For example, when duty cycles including sequential 1 second excitations separated by 0.5 second relaxations are applied to a working electrode using a combination DBL/reagent layer having an average initial thickness of 30 μm , a preferred diffusion rate may not be reached until at least 6 duty cycles have been applied ($>\sim 10$ seconds). Conversely, when the same duty cycles are applied to a working electrode using a combination DBL/reagent layer having an average initial thickness of 11 μm , a relatively constant diffusion rate may be reached after the second excitation (~ 2.5 seconds). Thus, there is an upper limit for the preferred average initial thickness of the DBL for a given duty cycle. A more in-depth treatment of the correlation between DBL thickness, excitation length, and time to reach a relatively constant diffusion rate may be found in U.S. Provisional

App. No. 60/655,180, filed February 22, 2005, entitled "Concentration Determination in a Diffusion Barrier Layer".

[00101] The distinct DBL 290 may include any material that provides the desired pore space, while being partially or slowly soluble in the sample. In one aspect, the distinct DBL 290 may include a reagent binder material lacking reagents. The distinct DBL 290 may have an average initial thickness of at least 5 μm , preferably, from 8 to 25 μm , and more preferably from 8 to 15 μm .

[00102] FIG. 3 represents an electrochemical analysis 300 for determining the presence and optionally the concentration of an analyte 322 in a sample 312. In 310, the sample 312 is introduced to a sensor strip 314, such as the sensor strip depicted in FIGs. 1A-1B and 2. The reagent layers, such as 275 and/or 285 from FIG. 2, begin to solubilize into the sample 312, thus allowing reaction. At this point in the analysis, it may be beneficial to provide an initial time delay, or "incubation period," for the reagents to react with the sample 312. Preferably, the initial time delay may be from 1 to 10 seconds. A more in-depth treatment of initial time delays may be found in U.S. Pat. Nos. 5,620,579 and 5,653,863.

[00103] During the reaction, a portion of the analyte 322 present in the sample 312 is chemically or biochemically oxidized or reduced in 320, such as by an oxidoreductase. Upon oxidation or reduction, electrons optionally may be transferred between the analyte 322 and a mediator 332 in 330.

[00104] In 340, a measurable species 342, which may be the charged analyte 322 from 320 or the charged mediator 332 from 330, is electrochemically excited (oxidized or reduced). For example, when the sample 312 is whole blood containing glucose that was oxidized by glucose oxidase in 320, which then transfers an electron to reduce a ferricyanide (III) mediator to ferrocyanide (II) in 330, the excitation of 340 oxidizes ferrocyanide (II) to ferricyanide (III) at the working electrode. In this manner, an electron is selectively transferred from the glucose analyte to the working electrode of the sensor strip where it may be detected by a measuring device.

[00105] The current resulting from the excitation 340 may be recorded during the excitation 340 as a function of time in 350. In 360, the sample undergoes relaxation. Preferably, the current is not recorded during the relaxation 360.

[00106] In 370, the excitation 340, the recordation 350, and the relaxation 360 are repeated at least twice for a total of at least three duty cycles within a 180 second or less

timeframe. The recorded current and time values may be analyzed to determine the presence and/or concentration of the analyte 322 in the sample 312 in 380.

[00107] Amperometric sensor systems apply a potential (voltage) to the sensor strip to excite the measurable species while the current (amperage) is monitored. Conventional amperometric sensor systems may maintain the potential while measuring the current for a continuous read pulse length of from 5 to 10 seconds, for example. In contrast to conventional methods, the duty cycles used in the electrochemical analysis 300 replace continuous, long-duration read pulses with multiple excitations and relaxations of short duration.

[00108] The analysis 300 may increase the accuracy and/or precision of the analyte determination when the measurable species excited at the working electrode in 540 is substantially drawn from the interior of a DBL, as opposed to the measurable species present in the cap-gap of the strip. FIGs. 4A and 4B depict a working electrode 400 having a surface conductor 430 and a distinct DBL 405 during the application of a long read pulse and a short excitation. When a WB sample is applied to the working electrode 400, RB cells 420 cover the DBL 405. Analyte present in the sample forms external measurable species 410 external to the DBL 405. A portion of the external measurable species 410 diffuses into the distinct DBL 405 to give internal measurable species 415.

[00109] As shown in FIG. 4A, when a continuous 10 second read pulse is applied to the working electrode 400, both the external and internal measurable species 410 and 415 are excited at the surface conductor 430 by a change in oxidation state. During the long read pulse, the external measurable species 410 diffuses through the sample region where the RB cells 420 reside and through the DBL 405 to the surface conductor 430. Diffusion of the external measurable species 410 through the RB cells 420 during the read pulse introduces the hematocrit effect to the analysis. Because a substantial portion of the measurable species excited at the surface conductor 430 originates from outside the DBL 420, a long read pulse applied to a sensor strip having a DBL may perform similarly with regards to the hematocrit effect to a short read pulse applied to a strip lacking a DBL.

[00110] Conversely, FIG. 4B represents the situation where a short excitation is applied to the DBL equipped sensor strip 400 to excite the internal measurable species 415, while substantially excluding from excitation the measurable species 410 external to the DBL 405. During the short excitation, the measurable species 410 either remains external to the DBL 405 or does not substantially diffuse through the DBL to reach the surface conductor

430. In this manner, the short excitation may provide a substantial reduction in the influence of the hematocrit effect on the analysis.

[00111] By controlling the length of excitation at the working electrode, the measurable species internal to the DBL may be analyzed, while the measurable species external to the DBL may be substantially excluded from analysis. In relation to the surface conductor 430 of the working electrode, the thickness and internal volume of the DBL 405 is believed to alter the diffusion rate of the internal measurable species 415 in relation to the diffusion rate of the external measurable species 410.

[00112] Because the measurable species internal to the DBL may diffuse at a different rate to the conductor of the working electrode than the measurable species external to the DBL, the length of the excitation at the working electrode may select which measurable species is preferentially analyzed. While identical from a molecular standpoint, the different diffusion rates of the measurable species internal and external to the DBL may allow differentiation.

[00113] While not wishing to be bound by any particular theory, it is presently believed that the rate of diffusion of the measurable species from outside the DBL into the DBL is varying, while the diffusion rate of the measurable species from the internal volume of the DBL to the conductor is relatively constant. The varying rate of diffusion of the measurable species outside the DBL may be caused by the RB cells and other constituents present in the sample and may give rise to the hematocrit effect. Thus, analysis errors (bias) introduced by the sample constituents, including RB cells, may be reduced by substantially limiting analysis to the measurable species having a relatively constant diffusion rate to the conductor.

[00114] Another advantage of selectively analyzing the measurable species internal to the DBL is a reduction of measurement imprecision from sensor strips having varying cap-gap volumes. If a read pulse continues past the time when substantially all of the measurable species present in the cap-gap has been analyzed, the analysis no longer represents the concentration of measurable species in the sample, but has instead determined the amount of measurable species in the cap-gap; a very different measurement. As the excitation length becomes long relative to the volume of the cap-gap, the current measurement will depend on the volume of the cap-gap, not the underlying analyte concentration. Thus, long read pulses may result in measurements that are highly inaccurate with regard to analyte concentration when the pulse length "overshoots" the measurable species present in the cap-gap.

[00115] As described in U.S. Provisional App. No. 60/617,889, filed October 12, 2004, entitled "Concentration Determination in a Diffusion Barrier Layer," a single short read pulse or excitation may be selected to substantially limit measurable species excitation to a DBL. When a single excitation is used, the length of the excitation and the thickness of the DBL may be preferably selected so that a relatively constant diffusion rate of the measurable species from the DBL to the conductor surface is reached during the excitation. If a relatively constant diffusion rate is not reached during the excitation, the concentration of the measurable species within the DBL may not accurately represent the concentration of the measurable species in the sample, thus adversely affecting the analysis. Furthermore, the single excitation may not effectively reduce the background signal from the mediator.

[00116] Referring to FIG. 3, the excitation 340, the recordation 350, and the relaxation 360 constitute a single duty cycle, which may be applied to a sensor strip at least three times during a 180 second or less time period. More preferably, at least 4, 6, 8, 10, 14, 18, or 22 duty cycles are applied during an independently selected 120, 90, 60, 30, 15, 10, or 5 second time period. In one aspect, the duty cycles are applied during a 5 to 60 second time period. In another aspect, from 3 to 18 or from 3 to 10 duty cycles may be applied within 30 seconds or less. In another aspect, from 4 to 8 duty cycles may be applied within 3 to 16 seconds.

[00117] The potential applied during the excitation 340 portion of the duty cycle is preferably applied at a substantially constant voltage and polarity throughout its duration. This directly contrasts to conventional read pulses where the voltage is changed or "swept" through multiple voltage potentials and/or polarities during data recordation. In one aspect, the duration of the excitation 340 is at most 4 or 5 seconds, and preferably less than 3, 2, 1.5, or 1 second. In another aspect, the duration of the excitation 340 is from 0.01 to 3 seconds, from 0.01 to 2 seconds, or from 0.01 to 1.5 seconds. More preferably, the duration of the excitation 340 is from 0.1 to 1.2 seconds.

[00118] After the excitation 340, in 360 the measuring device may open the circuit through the sensor strip 314, thus allowing the system to relax. During the relaxation 360, the current present during the excitation 340 is substantially reduced by at least one-half, preferably by an order of magnitude, and more preferably to zero. Preferably, a zero current state is provided by an open circuit or other method known to those of ordinary skill in the art to provide a substantially zero current flow. At least 3 relaxations may be provided during the duty cycles of the pulse sequence.

[00119] In one aspect, the relaxation 360 is at least 10, 5, 3, 2, 1.5, 1, or 0.5 seconds in duration. In another aspect, the relaxation 360 is from 0.1 to 3 seconds, from 0.1 to 2 seconds, or from 0.1 to 1.5 seconds in duration. More preferably, the relaxation 360 is from 0.2 to 1.5 seconds in duration and provided by an open circuit.

[00120] During the relaxation 360, the ionizing agent may react with the analyte to generate additional measurable species without the effects of an electric potential. Thus, for a glucose sensor system including glucose oxidase and a ferricyanide mediator as reagents, additional ferrocyanide (reduced mediator) responsive to the analyte concentration of the sample may be produced without interference from an electric potential during the relaxation 360.

[00121] Many conventional analysis methods continuously apply a voltage during the duration of the read pulse. The applied voltage may have a fixed potential or may have a potential that is swept from a positive to a negative potential or from a positive or a negative potential to a zero potential relative to a potential. Even at a zero relative potential, these methods continuously draw current from the sensor strip during the read pulse, which permits the electrochemical reaction to continue throughout the read pulse. Thus, the reaction that produces measurable species responsive to the analyte concentration and the diffusion of the measurable species to the working electrode are both affected by current during the zero potential portion of a conventional read pulse.

[00122] Conventional methods that continuously apply voltage to and draw current from the sensor strip, even at a zero potential in relation to a potential, are fundamentally different from the relaxations of the present invention. The multiple duty cycles applied by the present invention also are markedly different from conventional methods that use a single long duration pulse with multiple measurements, such as those disclosed in U.S. Pat. No. 5,243,516, due to the multiple relaxations of the present invention. In contrast to these conventional methods, each duty cycle of the pulse sequences of the present invention provides an independent diffusion and analyte reaction time during the relaxation.

[00123] FIGs. 5A-5E depict five examples of gated amperometric pulse sequences where multiple duty cycles were applied to the sensor strip after introduction of the sample. In these examples, square-wave pulses were used; however, other wave types compatible with the sensor system and the test sample also may be used. FIGs. 5C-5D depict pulse sequences including multiple duty cycles having the same excitation and open circuit delay times.

[00124] FIGs. 5A-5B depict pulse sequences that include 9 duty cycles having the same excitation and open circuit delay times in addition to a terminal read pulse 510 of longer duration that increases in voltage. The increased voltage of this terminal read pulse provides the ability to detect a species having a higher oxidation potential. A more complete discussion regarding terminal read pulses may be found in U.S. Provisional App. No. 60/669,729, filed April 8, 2005, entitled "Oxidizable Species as an Internal Reference in Control Solutions for Biosensors."

[00125] FIG. 5A depicts a 9 duty cycle pulse sequence where 0.5 second excitations are separated by 1 second open circuit delays to give a redox intensity (RI) of 0.357 (5/14). Thus, in FIG. 5A, the second duty cycle has an excitation portion 520 and a relaxation portion 530. FIG. 5B depicts a 9 duty cycle pulse sequence where 1 second excitations are separated by 0.5 second open circuit delays to give a RI of 0.69 (10/14.5). FIG. 5C depicts an 7 duty cycle pulse sequence where 1 second excitations are separated by 1 second open circuit delays to give a RI of 0.53 (8/15). A terminal read pulse 540 of the same duration and voltage as those used during the 7 duty cycles was applied. FIG. 5D depicts a 6 duty cycle pulse sequence where 1.5 second excitations are separated by 1 second open circuit delays to give a RI of 0.636 (10.5/16.5). As in FIG. 5C, the terminal read pulse 540 of the same duration and voltage as the prior duty cycle pulses was applied. FIG. 5E depicts a 7 duty cycle pulse sequence where relatively short 0.25 second excitations are separated by relatively long 1.5 second relaxations. The FIG. 5E pulse sequence begins with an initial 1 second pulse 550 and ends with the 1.25 second terminal read pulse 540 to provide a RI of 0.25 (4/16).

[00126] The higher the RI for a pulse sequence, the less background will be introduced into the analysis by the mediator. The pulse sequences represented in FIGs. 5A-5E are oxidative pulses, designed to excite (i.e. oxidize) a reduced mediator, which is the measurable species. Thus, the greater the oxidative current applied to the sensor strip in a given time period, the less chance that mediator reduced by pathways other than oxidation of the analyte is contributing to the recorded current values.

[00127] Table III, below, provides the slope, intercept, and ratio of intercept-to-slope for the contour profiles of the last four duty cycles of pulse sequences (a) and (b). Pulse sequence (a) was:

$9 \times (0.5 \text{ sec on} + 1.0 \text{ sec off}) + 0.5 \text{ sec} = 14 \text{ sec}$, $RI = 5/14 = 0.357$.

Pulse sequence (b) was:

$9 \times (1.0 \text{ sec on} + 0.375 \text{ sec off}) + 1.0 \text{ sec} = 13.375 \text{ sec}$, $RI = 10/13.375 = 0.748$

	Pulse Sequence (a), RI = 0.357			Pulse Sequence (b), RI = 0.748		
Pulse #	Slope	Intercept	Int/Slope	Slope	Intercept	Int/Slope
7	20.5	2581.6	125.93	14.07	741.29	52.69
8	19.99	2239.4	112.03	13.47	649.93	48.25
9	19.53	1973.4	101.04	12.92	580.94	44.96
10	19.1	1762.5	92.28	12.45	525.26	42.19

Table III

[00128] The intercept-to-slope ratios provide an indication of the amount of background signal attributable to the mediator, with higher ratio values indicating a greater proportion of the recorded signal attributable to mediator background. Thus, while the pulse frequency (number of excitations / total assay time in seconds) of sequences (a) and (b) are similar at about 0.7 sec^{-1} , the increase in RI provided by pulse sequence (b) provides less than half as much background signal. In combination, the multiple excitations of the pulse sequence may eliminate the need for an initial pulse to renew the oxidation state of the mediator. While the background current may be influenced by the mediator, for ferricyanide, pulse sequences having RI values of at least 0.01, 0.3, 0.6, or 1 are preferred, with RI values of from 0.1 to 0.8, from 0.2 to 0.7, or from 0.4 to 0.6 being more preferred.

[00129] Referring back to FIG. 3, in 350 the current passing through the conductors of the sensor strip 314 for each duty cycle of the pulse sequence may be recorded as a function of time. FIG. 6A shows the output currents plotted as a function of time for the pulse sequence represented in FIG. 5B for 40% hematocrit WB samples containing 50, 100, 200, 400, and 600 mg/dL glucose. Instead of a conventional long duration read pulse resulting in extensive oxidation of the measurable species, each excitation is followed by a break in the current profile.

[00130] In FIG. 6A, when the output currents are plotted as a function of time, each excitation results in a transient current profile having an initial high current value that decays over time. Preferably, the duty cycles include short, independent excitations and relaxations that inhibit the system from reaching a steady-state or a slow current decay condition during

each excitation, as required during the read pulse of conventional systems. Instead of conventional steady-state or slowly decaying currents, transient (rapidly decaying) current values are obtained from the gated amperometric pulse sequences because the electrochemical reaction of the measurable species at the working electrode is faster than the rate at which the measurable species is supplied to the working electrode by diffusion.

[00131] FIG. 6B shows a contour profile plot prepared by connecting the final current value from each of the transient current profiles (i.e. the final current value from each excitation) shown in FIG. 6A. The contour profile may be used to simulate the data obtained from a conventional system at steady-state, where the current change with time is substantially constant.

[00132] The transient current profiles obtained from gated amperometric pulse sequences and the derived contour current values are fundamentally different from the current profiles obtained from a conventional analysis using a single read pulse. While currents recorded from a single read pulse derive from a single relaxation/diffusion, each time point in the contour profile of the transient currents originates from an excitation after an independent relaxation/diffusion process. Furthermore, as the length of an excitation increases, the correlation between the current and the analyte concentration may decrease, often due to the hematocrit effect. Thus, the accuracy of an analysis using multiple, short excitations may be increased in comparison to an analysis using a longer read pulse having the duration of the multiple excitations combined.

[00133] Referring back to FIG. 6A, a transient point 605 is reached in the current profile when the last in time current value obtained for an excitation represents the greatest last in time current value obtained for any excitation. Thus, for FIG. 6A the transient point is reached at approximately 5 seconds. For each of the glucose concentrations, equilibrium with regards to DBL re-hydration may be reached at the highest current value in the contour profile for each glucose concentration. Thus, when the transient currents of FIG. 6A are converted to contour currents in FIG. 6B, reading 610 (highest) and 620 (lower) establish that equilibrium was reached regarding diffusion of the measurable species into the DBL and re-hydration of the DBL at about five seconds for the 600 mg/dL glucose concentration.

[00134] Current values recorded at a relatively constant diffusion rate minimize inaccuracies that would otherwise be introduced by variations in the rehydration and diffusion rates of the reagents. Thus, once a relatively constant diffusion rate is reached, the recorded current values more accurately correspond to the concentration of the measurable

species, and thus the analyte. Furthermore, for FIG. 6B, the complete analysis may be completed in as few as seven seconds because once the highest current value 610 of the contour profile is known, its value may be directly correlated to the analyte concentration. Additional data points may be obtained to reduce background error attributable to the mediator, as previously discussed.

[00135] FIG. 6C shows current contour profiles prepared from transient current profiles generated by the pulse sequence depicted in FIG. 5E. During each 0.25 second excitation, current values were recorded at the middle (~0.125 second) and end (~0.25 second), which may be used to determine a decay constant. Using the longer initial pulse with the short excitations and relatively long relaxations, the analysis may be completed in about four seconds.

[00136] FIG. 6D is a graph illustrating output signals in relation to input signals for an electrochemical system using gated amperometric pulse sequences. The input signals are potentials applied to a sample of biological fluid. The input signals include a polling input signal and an assay input signal. The output signals are currents generated from the sample. The output signals include a polling output signal and an assay output signal. The sample generates the assay output signal from a redox reaction of glucose in whole blood in response to the assay input signal. The input and output signals may be for a biosensor having working and counter electrodes. Other biosensors may be used including those with additional electrodes and different configurations. Other analyte concentrations may be measured including those in other biological fluids. Other output signals may be generated including those that decline initially and those that decline in all pulses.

[00137] In use, a sample of the biological fluid is deposited in a biosensor. The biosensor applies a polling signal to the sample from about -1.25 seconds through about 0 seconds. The pulses have a pulse width of about 5 – 10 ms and a pulse interval of about 125 ms. The biosensor generates a polling output signal in response to the polling input signal. The biosensor measures the polling output signal. The biosensor may have a potentiostat that provides the polling output signal to the input of an analog comparator.

[00138] When the polling output signal is equal to or greater than a polling threshold, the biosensor applies the assay input signal to the electrodes from about 0 seconds through about 7 seconds. The polling threshold value may be about 250 nA. The comparator may compare the polling output signal to the polling threshold value. When the polling output

signal exceeds the polling threshold value, the output signal of the comparator may trigger the launch of the assay input signal.

[00139] During the assay input signal, the biosensor applies a duty cycle with a first pulse having a potential of about 400 mV for about 1 sec to the working and counter electrodes. The first pulse is followed by a 0.5 sec relaxation, which may be an essentially open circuit or the like. The assay output signal or current within the first pulse is measured and stored in a memory device. The biosensor may apply a second pulse to the working and counter electrodes at about 200 mV for about 1 sec. The assay output signal or current within the second pulse is measured and stored in a memory device. The biosensor continues applying pulses from the assay input signal to the working and counter electrodes until the end of the assay period or for as long as desired by the biosensor. The assay period may be about 7 seconds. The biosensor may measure and store assay output signal or current within each pulse.

[00140] The polling input signal is an electrical signal, such as current or potential, that pulses or turns on and off at a set frequency or interval. The sample generates a polling output signal in response to the polling input signal. The polling output signal is an electrical signal, such as current or potential. The biosensor may show the polling output signal on a display and/or may store the assay output signal in a memory device. The biosensor may apply the polling signal to detect when a sample connects with the electrodes. The biosensor may use other methods and devices to detect when a sample is available for analysis.

[00141] The polling input signal is duty cycle in which a sequence of polling pulses is separated by polling relaxations. During a polling pulse, the electrical signal is on. During a polling relaxation, the electrical signal is off. On may include time periods when an electrical signal is present. Off may include time periods when an electrical signal is not present. Off may not include time periods when an electrical signal is present but has essentially no amplitude. The electrical signal may switch between on and off by closing and opening an electrical circuit, respectively. The electrical circuit may be opened and closed mechanically, electrically, or the like.

[00142] A polling input signal may have one or more polling pulse intervals. A polling pulse interval is the sum of a polling pulse and a polling relaxation. Each polling pulse has an amplitude and a polling pulse width. The amplitude indicates the intensity of the potential, the current, or the like of the electrical signal. The amplitude may vary or be a constant during the polling pulse. The polling pulse width is the time duration of a polling

pulse. The polling pulse widths in a polling input signal may vary or be essentially the same. Each polling relaxation has a polling relaxation width, which is the time duration of a polling relaxation. The polling relaxation widths in a polling input signal may vary or be essentially the same.

[00143] The polling input signal may have a polling pulse width of less than about 300 milliseconds (ms) and a polling pulse interval of less than about 1 sec. The polling input signal may have a polling pulse width of less than about 100 ms and a polling pulse interval of less than about 500 ms. The polling input signal may have a polling pulse width in the range of about 0.5 ms through about 75 ms and a polling pulse interval in the range of about 5 ms through about 300 ms. The polling input signal may have a polling pulse width in the range of about 1 ms through about 50 ms and a polling pulse interval in the range of about 10 ms through about 250 ms. The polling input signal may have a polling pulse width of about 5 ms and a polling pulse interval of about 125 ms. The polling input signal may have other pulse widths and pulse intervals.

[00144] The biosensor may apply the polling input signal to the sample during a polling period. The polling period may be less than about 15 minutes, 5 minutes, 2 minutes, or 1 minute. The polling period may be longer depending upon how a user uses the biosensor. The polling period may be in the range of about 0.5 second (sec) through about 15 minutes. The polling period may be in the range of about 5 sec through about 5 minutes. The polling period may be in the range of about 10 sec through about 2 minutes. The polling period may be in the range of about 20 sec through about 60 sec. The polling period may be in the range of about 30 through about 40 sec. The polling period may have less than about 200, 100, 50, or 25 pulse intervals. The polling period may have from about 2 through about 150 pulse intervals. The polling period may have from about 5 through about 50 pulse intervals. The polling period may have from about 5 through about 15 pulse intervals. The polling period may have about 10 pulse intervals. Other polling periods may be used.

[00145] The biosensor applies the assay input signal when the polling output signal is equal to or greater than a polling threshold. The polling threshold may be greater than about 5 percent (%) of the expected assay input signal at the beginning of the first pulse. The polling threshold may be greater than about 15% of the expected assay input signal at the beginning of the first pulse. The polling threshold may be in the range of about 5 percent (%) through about 50% of the expected assay input signal at the beginning of the first pulse.

Other polling thresholds may be used. The biosensor may indicate the polling output signal is equal to or greater than the polling threshold on a display.

[00146] The assay input signal is an electrical signal, such as current or potential, that pulses or turns on and off at a set frequency or interval. The sample generates an assay output signal in response to the assay input signal. The assay output signal is an electrical signal, such as current or potential.

[00147] The assay input signal is a sequence of assay pulses separated by assay relaxations. During an assay pulse, the electrical signal is on. During an assay relaxation, the electrical signal is off. On includes time periods when an electrical signal is present. Off includes time periods when an electrical signal is not present and does not include time periods when an electrical signal is present but has essentially no amplitude. The electrical signal switches between on and off by closing and opening an electrical circuit, respectively. The electrical circuit may be opened and closed mechanically, electrically, or the like.

[00148] An assay input signal may have one or more assay pulse intervals. An assay pulse interval is the sum of an assay pulse and an assay relaxation. Each assay pulse has an amplitude and an assay pulse width. The amplitude indicates the intensity of the potential, the current, or the like of the electrical signal. The amplitude may vary or be a constant during the assay pulse. The assay pulse width is the time duration of an assay pulse. The assay pulse widths in an assay input signal may vary or be essentially the same. Each assay relaxation has an assay relaxation width, which is the time duration of an assay relaxation. The assay relaxation widths in an assay input signal may vary or be essentially the same.

[00149] The assay input signal may have an assay pulse width of less than about 5 sec and an assay pulse interval of less than about 15 sec. The assay input signal may have an assay pulse width of less than about 3, 2, 1.5, or 1 sec and an assay pulse interval of less than about 13, 7, 4, 3, 2.5, or 1.5 sec. The assay input signal may have an assay pulse width in the range of about 0.1 sec through about 3 sec and an assay pulse interval in the range of about 0.2 sec through about 6 sec. The assay input signal may have an assay pulse width in the range of about 0.1 sec through about 2 sec and an assay pulse interval in the range of about 0.2 sec through about 4 sec. The assay input signal may have an assay pulse width in the range of about 0.1 sec through about 1.5 sec and an assay pulse interval in the range of about 0.2 sec through about 3.5 sec. The assay input signal may have an assay pulse width in the range of about 0.4 sec through about 1.2 sec and an assay pulse interval in the range of about 0.6 sec through about 3.7 sec. The assay input signal may have an assay pulse width in the

range of about 0.5 sec through about 1.5 sec and an assay pulse interval in the range of about 0.75 sec through about 2.0 sec. The assay input signal may have an assay pulse width of about 1 sec and an assay pulse interval of about 1.5 sec. The assay input signal may have other pulse widths and pulse intervals.

[00150] The biosensor applies the assay input signal to the sample during an assay period. The assay period may have the same or a different duration than the polling period. The assay period of the assay input signal may be less than about 180, 120, 90, 60, 30, 15, 10, or 5 sec. The assay period may be in the range of about 1 sec through about 100 sec. The assay period may be in the range of about 1 sec through about 25 sec. The assay period may be in the range of about 1 sec through about 10 sec. The assay period may be in the range of about 2 sec through about 3 sec. The assay period may be about 2.5 sec. The assay period may have less than about 50, 25, 20, 15, 10, 8, 6, or 4 assay pulse intervals. The assay period may have assay pulse intervals in the range of about 2 through about 50. The assay period may have assay pulse intervals in the range of about 2 through about 25. The assay period may have assay pulse intervals in the range of about 2 through about 15. The assay period may have about 10 assay pulse intervals. Other assay periods may be used.

[00151] FIGs. 7A and 7B are graphs illustrating the improvement in measurement accuracy when a DBL is combined with a short read pulse. Whole blood samples were combined with ferrocyanide in a 1:5 dilution ratio to represent an underlying glucose concentration and measured with a 1 second read pulse. Thus, the initial 20%, 40%, and 60% hematocrit WB samples were diluted to 16%, 32%, and 48% hematocrit (a 20% reduction of all three hematocrit values). The 20%, 40%, and 60% lines represent the current measured for the blood samples containing 16%, 32%, and 48% hematocrit, respectively.

[00152] FIG. 7A shows the inaccuracies introduced by the hematocrit and other effects from a bare conductor sensor strip lacking a DBL. The inaccuracy is represented as the difference between the 20% and 60% hematocrit lines (the total hematocrit bias span) and represents the maximum measurement inaccuracy attributable to the hematocrit effect. Smaller bias values represent a more accurate result. Similar performance was observed when a DBL was used with a longer read pulse as discussed above with regard to FIG. 4A.

[00153] Conversely, FIG. 7B shows a marked decrease in the distance between the 20% and 60% calibration lines when a DBL is combined with a 1 second read pulse. A distinct DBL of PEO polymer and 10% KCl (without reagents) was printed on a conductor as used for FIG. 7A above. The total bias hematocrit span with the DBL/short read pulse was

nearly two-thirds less than the total bias span without the DBL. Thus, pulse sequences including multiple duty cycles in combination with a DBL may significantly increase measurement accuracy and provide a desirable reduction in mediator background.

[00154] FIGs. 7C and 7D illustrate the reduction in hematocrit bias that may be obtained when a gated amperometric pulse sequence is combined with a DBL. FIG. 7C demonstrates that the measurement bias attributable to hematocrit effect is within $\pm 5\%$ when a DBL was combined with the pulse sequence of FIG. 5E and the current values were recorded at 14.875 seconds or 0.125 seconds from the last pulse. For comparison, FIG. 7D establishes that bias increases to $\pm 15\%$ when current value at 16 seconds (1.25 seconds from the last pulse) is used to determine the glucose concentration of the sample. Thus, the longer the duration of the excitation, the greater the hematocrit bias observed.

[00155] In addition to the ability of the present invention to reduce inaccuracy from the hematocrit effect and mediator background signal, the combination of the transient current profile of each excitation and the resulting contour profiles may be used to provide multiple sets of calibration constants to the sensor system, thus increasing the accuracy of the analysis. Each set of calibration constants obtained may be used to correlate a specific current reading to a specific concentration of measurable species in the sample. Thus, in one aspect, an increase in accuracy may be obtained by averaging the glucose values obtained using multiple sets of calibration constants.

[00156] Conventional electrochemical sensor systems generally use one set of calibration constants, such as slope and intercept, to convert current readings into corresponding concentration of the analyte in the sample. However, a single set of calibration constants may result in inaccuracies in the analyte concentration determined from the recorded current values because random noise is included in the measurement.

[00157] By taking the current value at a fixed time within each duty cycle of the pulse sequences of the present invention, multiple sets of calibration constants may be established. FIG. 8 plots the endpoint currents recorded at 8.5, 10, 11.5, 13, and 14.5 seconds (duty cycles 6-9 and first portion of the terminal read pulse) when the pulse sequence depicted in FIG. 5B was applied to WB samples containing various glucose concentrations. Each of these five calibration lines are independent of the other and may be used in at least two ways.

[00158] First, the multiple sets of calibration constants may be used to determine the number of duty cycles that should be applied during the pulse sequence to obtain the desired accuracy, precision, and assay time. For example, if the current values obtained from the first

three excitations indicate a high glucose concentration, such as >150 or 200 mg/dL, the sensor system may terminate the analysis at about 5.5 seconds, thus considerably shortening the time required for the analysis. Such a shortening may be possible because imprecision at high glucose concentrations is typically less than at lower glucose concentrations. Conversely, if the current values obtained from the first three excitations indicate a low glucose concentration, such as ≤ 150 or 100 mg/dL, the sensor system may extend the analysis to greater than 7, such as greater than 8 or 10 seconds, to increase the accuracy and/or precision of the analysis.

[00159] Second, the multiple sets of calibration constants may be used to increase the accuracy and/or precision of the analysis by averaging. For example, if the target glucose measurement time is 11.5 seconds, the currents at 8.5, 10, and 11.5 seconds can be utilized to calculate the glucose concentrations using the slopes and intercepts from the corresponding calibration lines; therefore, $G_{8.5} = (i_{8.5} - \text{Int}_{8.5})/\text{Slope}_{8.5}$, $G_{10} = (i_{10} - \text{Int}_{10})/\text{Slope}_{10}$, and $G_{11.5} = (i_{11.5} - \text{Int}_{11.5})/\text{Slope}_{11.5}$. Theoretically, these three glucose values should be equivalent, differing only by random variations. Thus, the glucose values $G_{8.5}$, G_{10} , and $G_{11.5}$ may be averaged and the final glucose value of $(G_{8.5} + G_{10} + G_{11.5})/3$ may be calculated. Averaging the values from the calibration lines may provide a reduction in noise at the rate of $1/\sqrt{3}$.

[00160] An unexpected benefit of gated amperometric pulse sequences including relatively short excitations and relatively long relaxations, such as that depicted in FIG. 5E, is the ability to simplify calibration. While the multiple sets of calibration constants that may be obtained from the transient and contour profiles may provide an advantage to the accuracy of the analysis, a pulse sequence such as depicted in FIG. 5E may provide similar accuracy to that obtained using multiple sets of calibration constants from a single set of calibration constants. While not intending to be bound by any particular theory, this result may be attributable to the relatively long relaxation times in comparison to the short relaxations. The long relaxation times may provide a state where the average rate of measurable species conversion during the excitation is balanced by the rate of measurable species diffusion into the DBL. In this manner, the multiple sets of calibration constants may collapse into a single set and the conversion of the recorded data into an analyte concentration may be simplified by carrying out the averaging process on the recorded current data before determining the analyte concentration.

[00161] The combination of the transient current profile of each excitation and the resulting contour profiles also may be used to determine if the sensor strip has been under-

filled with sample, thus allowing the user to add additional sample to the sensor strip. In addition to working and counter electrodes, conventional sensor systems may determine an under-fill condition through the use of a third electrode or electrode pair; however, the third electrode or electrode pair adds complexity and cost to the sensor system.

[00162] Conventional two electrode systems may be able to recognize that an analysis is “bad,” but may not determine if the reason for the failed analysis was caused by under-fill or a defective sensor strip. The ability to determine if under-fill caused the failure of the analysis is beneficial because it may be corrected by adding additional sample to the same sensor strip and repeating the analysis, thus preventing a good strip from being discarded.

[00163] FIG. 9A depicts the transient current profiles obtained from the pulse sequence represented in FIG. 5B for 10 analyses, each using a different sensor strip, where 2.0 μL of sample was introduced to the strip. Depending on the filling speed and the cap-gap volume of a specific sensor strip, 2.0 μL of sample may or may not be enough to fill the strip.

[00164] In FIG. 9B the transient current profiles of FIG. 9A were converted to contour profiles of decay rate as a function of time. In one aspect, the decay rate may be represented as a K constant determined by either of the following equations:

$$K_1 = \frac{\ln(i_{0.125}) - \ln(i_{1.0})}{\ln(t_{0.125}) - \ln(t_{1.0})}$$

$$K_2 = \frac{\ln(i_{0.5}) - \ln(i_{1.0})}{\ln(t_{0.5}) - \ln(t_{1.0})}$$

where the 0.125, 0.5, and 1.0 values are in seconds. Thus, using the K constant of a decay process, the current profiles of FIG. 9A may be converted into the decay constant profiles of FIG. 9B.

[00165] FIG. 9B establishes that a substantial difference exists between the decay profiles of the under-filled sensors and the normal-filled sensors, especially in the time range of 3 to 7 seconds. Under-fill may be determined from the decay constant profiles by comparing the difference between the actual decay constant and a previously selected value. For example, if -0.1 is selected as the upper limit for a normal-filled sensor with regard to FIG. 9B, any K_1 constant having a value lower than -0.1 determined from excitations during the 3 to 5 second time period may be considered normal-filled. Similarly, any sensor having a K_1 value higher than -0.1 may be considered under-filled. In this manner, the under-fill may be determined in response to a decay rate obtained from a transient current profile.

[00166] Thus, in FIG. 9B the sensor strips represented by series 3 and 8 were sufficiently filled, while the eight sensor strips represented by series 1-2, 4-7, and 9-10 were under-filled. In this manner, the gated amperometric pulse sequences of the present invention allowed for under-fill detection in a two-electrode sensor strip, a function typically requiring a third electrode for conventional sensor systems. Furthermore, the under-fill determination was made in less than ten seconds, providing time for the measuring device to signal the user, such as by sending a signal to a light emitting device or a display, to add more sample to the strip.

[00167] Because under-fill may be determined from the transient current profiles, the same current values used to determine the presence and/or concentration of the analyte may be used to determine if an under-fill condition exists. Thus, under-fill may be determined during the multiple duty cycles of the pulse sequence without lengthening the duration of the electrochemical analysis beyond that required for concentration determination.

[00168] The combination of the transient current profile of each excitation and the resulting contour profile also may be used to determine if a change in the temperature of the sample may adversely affect the analysis. Conventional sensor systems include a thermistor in the measuring device or on the strip to provide the temperature of the device or strip, respectively. While this temperature is an approximation of the sample temperature, typically, the device or strip is at a different temperature than the sample. The temperature difference between the device or strip and the sample may introduce bias into the analysis.

[00169] By determining a decay rate, such as with a K constant as previously discussed, the temperature of the sample may be determined. FIG. 10 depicts K constants plotted as a function of temperature that were obtained from the fifth excitation of a pulse sequence for glucose concentrations of 50, 100, and 400 mg/dL. The plots establish that the decay rate increased in absolute value with increasing temperature. While not wishing to be bound by any particular theory, this phenomenon may be attributed to lower temperatures slowing down the diffusion rate of the various constituents present in the cap-gap. In this manner, the temperature of a sample may be determined in response to a decay rate obtained from a transient current profile.

[00170] Because sample temperature may be determined from the transient current profiles, the same current values used to determine the presence and/or concentration of the analyte may be used to determine the temperature of the sample. Thus, the temperature of the sample may be determined during the multiple duty cycles of the pulse sequence without

lengthening the duration of the electrochemical analysis beyond that required for concentration determination.

[00171] In one aspect, the temperature of the sample may be determined by solving for K by the following equation:

$$K = \frac{\ln i_{0.125} - \ln i_{0.375}}{\ln(0.125) - \ln(0.375)}$$

where $i_{0.125}$ and $i_{0.375}$ are the currents at 0.125 and 0.375 seconds from the excitation most sensitive to temperature change, such as the excitation generating the most sensitive current decay with respect to the temperature change. $\ln(0.125)$ and $\ln(0.375)$ are the natural logarithmic terms of the times at 0.125 and 0.375 seconds, respectively. From the plot of these K constants verses temperature, as depicted in FIG. 10, the temperature of the sample may be determined by the correlation function of the plot. The correlation function may be a polynomial fit of the curve. The temperature determined from this plot may be different from the temperature of the device and may more accurately reflect the temperature of the sample.

[00172] An advantage of determining the temperature of the sample, as opposed to the device, is that the length of the analysis may be adjusted to allow sufficient time for the rehydration of a DBL to reach equilibrium, thus increasing the accuracy of the analysis. For example, if the temperature of the sample determined during the pulse sequence is at least 5 or 10° C below ambient temperature, the pulse sequence may be lengthened, such as with additional duty cycles.

[00173] FIG. 11 is a schematic representation of a measuring device 1100 including contacts 1120 in electrical communication with electrical circuitry 1110 and a display 1130. In one aspect, the measuring device 1100 is portable and is adapted to be handheld and to receive a sensor strip, such as the strip 100 from FIG. 1A. In another aspect, the measuring device 1100 is a handheld measuring device adapted to receive a sensor strip and implement gated amperometric pulse sequences.

[00174] The contacts 1120 are adapted to provide electrical communication with the electrical circuitry 1110 and the contacts of a sensor strip, such as the contacts 170 and 180 of the sensor strip 100 depicted in FIG. 1B. The electrical circuitry 1110 may include an electric charger 1150, a processor 1140, and a computer readable storage medium 1145. The electrical charger 1150 may be a potentiostat, signal generator, or the like. Thus, the charger 1150 may apply a voltage to the contacts 1120 while recording the resulting current to function as a charger-recorder.

[00175] The processor 1140 may be in electrical communication with the charger 1150, the computer readable storage medium 1145, and the display 1130. If the charger is not adapted to record current, the processor 1140 may be adapted to record the current at the contacts 1120.

[00176] The computer readable storage medium 1145 may be any storage medium, such as magnetic, optical, semiconductor memory, and the like. The computer readable storage medium 1145 may be a fixed memory device or a removable memory device, such as a removable memory card. The display 1130 may be analog or digital, in one aspect a LCD display adapted to displaying a numerical reading.

[00177] When the contacts of a sensor strip containing a sample are in electrical communication with the contacts 1120, the processor 1140 may direct the charger 1150 to apply a gated amperometric pulse sequence to the sample, thus starting the analysis. The processor 1140 may start the analysis in response to the insertion of a sensor strip, the application of a sample to a previously inserted sensor strip, or in response to a user input, for example.

[00178] Instructions regarding implementation of the gated amperometric pulse sequence may be provided by computer readable software code stored in the computer readable storage medium 1145. The code may be object code or any other code describing or controlling the functionality described in this application. The data that results from the gated amperometric pulse sequence may be subjected to one or more data treatments, including the determination of decay rates, K constants, slopes, intercepts, and/or sample temperature in the processor 1140 and the results, such as a corrected analyte concentration, output to the display 1130. As with the instructions regarding the pulse sequence, the data treatment may be implemented by the processor 1140 from computer readable software code stored in the computer readable storage medium 1145.

[00179] Without limiting the scope, application, or implementation, the methods and systems previously described may be implemented using the following algorithm:

- [00180] Step 1: Turn on biosensor power
- [00181] Step 2: Perform biosensor self-test
- [00182] Step 3: Setup to poll for application of sample to sensor
Set ASIC polling potential to v_{poll}
Set ASIC threshold level to $i_{trigger}$
Set polling periodic timer to expire at int_{poll}

- [00183] Step 4: Setup for assaying the sensor current
 Wait for polling periodic timer to expire
 Enable ASIC charge pump
 Enable ASIC threshold detector (i_{trigger})
 Enable polling potential (v_{poll})
 Select sensor channel which applies potential to sensor
 Wait for settling time t_{poll}
- [00184] Step 5: Test if the sensor current exceeds the threshold
- [00185] Step 6: Delay and test sensor current again
- [00186] Step 7: Upon detection of Sample Application
 start counting time
 launch pulse sequence
- [00187] Step 8: Pulse 1 – Measure sensor currents $i_{1,1}$ and $i_{1,8}$
 Pulse 1 starts at time t_{p1}
 Set Pulse 1 duration to d_{p1}
 Set Pulse 1 sensor potential to v_{p1}
 Select sensor channel to apply potential to sensor
 At time $t_{1,1}$, measure sensor signal, save value as AD_{S11}
 At time $t_{1,8}$, measure sensor signal, save value as AD_{S18}
- [00188] Step 9: Delay 1 – Re-standardize electronics
 Delay 1 starts at end of AD_2 reading, disconnect sensor channel
 Delay 1 ends at beginning of Pulse 2
 Set potential to $V_{\text{standardize}}$
 At time t_{c1} , select reference resistor channel then measure signal, save value as AD_{R1}
 At time t_{c2} , select offset channel then measure signal, save value as AD_{O1}
 Note: sensor currents starting at Pulse 1 are calculated from the AD_{R1} and AD_{O1} measurements
- [00189] Step 10: Pulse 2 - Measure sensor currents $i_{2,1}$ and $i_{2,8}$
 Pulse 2 starts at time t_{p2}
 Set Pulse 2 duration to d_{p2}

- Set Pulse 2 sensor potential to v_{p2}
 Select sensor channel to apply potential to sensor
 At time $t_{2,1}$, measure sensor signal, save value as AD_{S21}
 At time $t_{2,8}$, measure sensor signal, save value as AD_{S28}
- [00190] Step 11: Delay 2 –
 Delay 2 starts at end of AD_{S3} reading, disconnect sensor channel
 Delay 2 ends at beginning of Pulse 3
 Select offset channel to disconnect sensor
- [00191] Step 12: Pulse 3 - Measure sensor currents: $i_{3,1}$ and $i_{3,8}$
 Pulse 3 starts at time t_{p3}
 Set Pulse 3 duration to d_{p3}
 Set Pulse 3 sensor potential to v_{p3}
 Select sensor channel to apply potential to sensor
 At time $t_{3,1}$, measure sensor signal, save value as AD_{S31}
 At time $t_{3,8}$, measure sensor signal, save value as AD_{S38}
- [00192] Step 13: Delay 3 – T_1 and i_{wet}
 Delay 3 starts at end of AD_{S38} reading, disconnect sensor channel
 Delay 3 ends at beginning of Pulse 4
 Set potential to $V_{standardize}$
 At time t_{c3} , select thermistor channel then measure signal, save value as AD_{T1}
 At time t_{wet} , select offset channel then measure signal, save value as AD_{wet}
- [00193] Step 14: Pulse 4 - Measure sensor currents: $i_{4,1}$, $i_{4,4}$, and $i_{4,8}$
 Pulse 4 starts at time t_{p4}
 Set Pulse 4 duration to d_{p4}
 Set Pulse 4 sensor potential to v_{p4}
 Select sensor channel to apply potential to sensor
 At time $t_{4,1}$, measure sensor signal, save value as AD_{S41}
 At time $t_{4,4}$, measure sensor signal, save value as AD_{S44}
 At time $t_{4,8}$, measure sensor signal, save value as AD_{S48}

- [00194] Step 15: Delay 4 –
 - Delay 4 starts at end of AD_{S48} reading, disconnect sensor channel
 - Delay 4 ends at beginning of Pulse 5
 - Select offset channel to disconnect sensor
- [00195] Step 16: Pulse 5 - Measure sensor currents: $i_{5,1}$, $i_{5,4}$, and $i_{5,8}$
 - Pulse 5 starts at time t_{p5}
 - Set Pulse 5 duration to d_{p5}
 - Set Pulse 5 sensor potential to v_{p5}
 - Select sensor channel to apply potential to sensor
 - At time $t_{5,1}$, measure sensor signal, save value as AD_{S51}
 - At time $t_{5,4}$ measure sensor signal, save value as AD_{S54}
 - At time $t_{5,8}$, measure sensor signal, save value as AD_{S58}
 - Disable ASIC analog functions
- [00196] Step 17: Look up slope and intercept for lot calibration number
 - S = Slope value for current lot calibration number
 - Int = Intercept value for current lot calibration number
- [00197] Step 18: Adjust slope and intercept for temperature effect
- [00198] Step 19: Calculate glucose concentration at 25°C
- [00199] Step 20: Convert to target reference (plasma vs. WB reference)
- [00200] Step 21: Check underfill
- [00201] Step 22: Check for “Abnormal Behavior”
- [00202] Step 23: If low glucose, check again for “Abnormal Behavior”
- [00203] Step 25: Check for extreme glucose levels
- [00204] Step 26: Display result

[00205] The algorithm may have other subroutines including those to check for errors such as sample temperature and underfill conditions. The constants that may be used in the algorithm are given in Table III below. Other constants may be used.

[00206]

Constant	Description	Value	Units
v_{poll}	polling voltage	400	mV
int_{poll}	polling interval	125	ms

Constant	Description	Value	Units
t_{poll}	polling duration	10	minutes
$i_{trigger}$	threshold detect trigger current	250	nA
t_{p1}	pulse 1 start time	0	sec
d_{p1}	pulse 1 duration	1	second
v_{p1}	pulse 1 voltage level	400	mV
$t_{1,1}$	time of sensor current reading 1	0.125	sec
$t_{1,8}$	time of sensor current reading 2	1.00	sec
t_{c1}	Offset reading time	1.125	sec
t_{c2}	Reference reading time	1.25	sec
t_{p2}	pulse 2 start time	1.5	sec
d_{p2}	pulse 2 duration	1	second
v_{p2}	pulse 2 voltage level	200	mV
$t_{2,1}$	time of sensor current reading 3	1.625	sec
$t_{2,8}$	time of sensor current reading 4	2.50	sec
t_{p3}	pulse 3 start time	3	sec
d_{p3}	pulse 3 duration	1	second
v_{p3}	pulse 3 voltage level	200	mV
$t_{3,1}$	time of sensor current reading 5	3.125	sec
$t_{3,8}$	time of sensor current reading 6	4.00	sec
t_{c3}	Thermistor reading time	4.125	sec
t_{wet}	Time of wet sensor current reading	4.25	sec
t_{p4}	pulse 4 start time	4.5	second
d_{p4}	pulse 4 duration	1	second
v_{p4}	pulse 4 voltage level	200	mV
$t_{4,1}$	time of sensor current reading 7	4.625	sec
$t_{4,4}$	time of sensor current reading 8	5.00	sec
$t_{4,8}$	time of sensor current reading 9	5.50	sec
t_{p5}	pulse 5 start time	6	sec
d_{p5}	pulse 5 duration	1	second
v_{p5}	pulse 5 voltage level	200	mV
$t_{5,1}$	time of sensor current reading 10	6.125	sec

Constant	Description	Value	Units
$t_{5,4}$	time of sensor current reading 11	6.50	sec
$t_{5,8}$	time of sensor current reading 12	7.00	sec

TABLE III

[00207] While various embodiments of the invention have been described, it will be apparent to those of ordinary skill in the art that other embodiments and implementations are possible within the scope of the invention.

CLAIMS:

1. A method of determining the concentration of an analyte in a sample, comprising:
 - applying a pulse sequence to the sample, the pulse sequence comprising at least 3 duty cycles within 180 seconds; and
 - 5 determining the concentration of the analyte in the sample.
2. The method of claim 1, wherein the concentration of the analyte determined from the method includes less bias attributable to mediator background than a concentration of the analyte determined from another method lacking the pulse sequence comprising at least 3 duty cycles within 180 seconds.
- 10 3. The method of claim 1, wherein the concentration of the analyte determined from the method includes less bias attributable to mediator background than a concentration of the analyte determined from the same method lacking the pulse sequence comprising at least 3 duty cycles within 180 seconds.
4. The method of claim 1, wherein the sample is a liquid comprising a
15 biological fluid.
5. The method of claim 1, wherein the analyte is glucose.
6. The method of claim 1, wherein each of the duty cycles comprises an excitation at a fixed potential and a relaxation.
7. The method of claim 6, wherein a current value is recorded during
20 each of the excitations.
8. The method of claim 1, wherein the pulse sequence comprises a terminal read pulse.
9. The method of claim 1, wherein the pulse sequence is applied to a sensor strip including a diffusion barrier layer on a working electrode.
- 25 10. The method of claim 1, further comprising measuring resulting currents and determining a plurality of calibration points from the currents.
11. The method of claim 10, wherein the duration of the pulse sequence is determined from the plurality of calibration points.
12. The method of claim 10, wherein the determining of the analyte
30 concentration includes a signal averaging including the plurality of calibration points.
13. The method of claim 1, further comprising determining if a sensor strip containing the sample is under-filled with the sample.

14. The method of claim 13, wherein the determining if a sensor strip containing the sample is under-filled includes determining a decay rate.

15. The method of claim 1, further comprising determining the temperature of the sample contained by a sensor strip.

5 16. The method of claim 15, wherein the determining of the temperature of the sample contained by a sensor strip includes determining a decay rate.

17. A handheld analyte measuring device, for determining the concentration of an analyte in a sample, comprising a gated amperometric measuring device adapted to receive a sensor strip, wherein

10 the gated amperometric measuring device comprises at least two device contacts in electrical communication with a display through electrical circuitry, and

the sensor strip comprises at least first and second sensor strip contacts, the first sensor strip contact in electrical communication with a working electrode and the second sensor strip contact in electrical communication with a counter electrode
15 through conductors, where

wherein a first reagent layer is on at least one of the electrodes, the first reagent layer comprises an oxidoreductase and at least one species of a redox pair.

18. A method of determining the concentration of an analyte in a sample, comprising the acts:

20 applying a pulse sequence to the sample, the pulse sequence comprising at least 3 duty cycles within 180 seconds;

measuring the resulting currents;

applying a data treatment to the measured currents; and

determining the concentration of the analyte in the sample.

25 19. A handheld measuring device, for determining the concentration of an analyte in a sample, the device being adapted to receive a sensor strip, the device comprising:

contacts;

at least one display; and

30 electronic circuitry establishing electrical communication between the contacts and the display, the circuitry comprising an electric charger and a processor in electrical communication, the processor in electrical communication with a computer readable storage medium comprising computer readable software code, which when

executed by the processor, causes the charger to implement a pulse sequence comprising at least 3 duty cycles within 180 seconds between the contacts.

20. A method of reducing the bias attributable to mediator background in a determined concentration of an analyte in a sample, the method comprising the acts of:

5 applying a pulse sequence to the sample, the pulse sequence comprising at least 3 duty cycles within 180 seconds.

21. A method of determining the duration of a pulse sequence including at least 3 duty cycles within 180 seconds, for determining the concentration of an

10 analyte in a sample, the method comprising the acts of:

determining a plurality of calibration points determined from currents recorded during the at least 3 duty cycles; and

determining the duration of the pulse sequence in response to the determined concentration of the analyte in the sample.

22. A method of signaling a user to add additional sample to a sensor strip, the method comprising the acts of:

determining if the sensor strip is under-filled by determining a decay constant from currents recorded during at least two excitations of a pulse sequence including at least 3 duty cycles within 180 seconds; and

20 signaling the user to add additional sample to the sensor strip if the strip is under-filled.

23. A method of determining the temperature of a sample contained by a sensor strip, the method comprising the acts of:

determining a decay constant from currents recorded during at least two

25 excitations of a pulse sequence including at least 3 duty cycles within 180 seconds; and

correlating the decay constant with a temperature value.

24. A method of determining the concentration of an analyte, the method comprising the acts of:

30 applying a pulse sequence to a sample of a biological fluid during a time period equal to or less than 180 seconds, the pulse sequence having at least three duty cycles, the duty cycle having an excitation at a substantially constant voltage, the duty cycle having a relaxation;

measuring at least one current profile; and
determining the concentration of the analyte in the sample in response to the at
least one current profile.

25. The method of claim 24, wherein the excitation is less than 5 seconds.

5 26. The method of claim 24, wherein the relaxation is responsive to an
open circuit.

27. The method of claim 24, wherein the relaxation is at least 0.5 seconds.

28. The method of claim 24, wherein the current profile is a transient
current profile.

10 29. The method of claim 24, wherein the current during a relaxation is
zero.

30. The method of claim 24, wherein the pulse sequence comprises square-
wave pulses.

31. The method of claim 24, wherein the pulse sequence has a redox
15 intensity of at least 0.01.

32. The method of claim 24, further comprising determining the
concentration of the analyte in response to a current profile when a relatively constant
diffusion rate of the measurable species is reached.

33. The method of claim 24, further comprising establishing multiple sets
20 of calibration constants in response to the at least one current profile.

34. The method of claim 33, further comprising determining the number of
duty cycles in the pulse sequence in response to the multiple sets of calibration
constants.

35. The method of claim 33, further comprising:
25 determining the concentration of the analyte in the sample in response to each
set of calibration constants; and

averaging the concentrations of the analyte from the sets of the calibration
constants.

36. The method of claim 24, further comprising determining when a sensor
30 strip is under-filled in response to the current profile.

37. The method of claim 36, further determining when a sensor strip is
under-filled when a decay rate of the current profile is less than a selected value.

38. The method of claim 37, wherein the selected value is -0.1.

39. The method of claim 24, further comprising determining a temperature of the sample in response to a decay rate of the current profile.

40. A method of determining an analyte in a biological fluid, the method comprising the acts of:

5 introducing a sample of the biological fluid to a sensor strip;

transferring at least one electron from an analyte in the sample to a mediator in the sensor strip;

applying a pulse sequence to the sample during a time period equal to or less than 180 seconds, the pulse sequence having at least three duty cycles, the duty cycle
10 having an excitation at a substantially constant voltage, the duty cycle having a relaxation;

analyzing a current responsive to the excitation of the measurable species; and determining an analyte in the sample in response to the current.

41. The method of claim 40, further comprising electrochemically exciting
15 a measurable species.

42. The method of claim 41, further comprising oxidizing the analyte in the sample.

43. The method of claim 41, further comprising reducing the analyte in the sample.

20 44. The method of claim 41, wherein the measurable species is the analyte.

45. The method of claim 41, wherein the measurable species is a mediator.

46. The method of claim 40, further comprising recording the current during the excitation as a function of time.

47. The method of claim 40, further comprising determining the presence
25 of an analyte in the sample.

48. The method of claim 40, further comprising determining the concentration of the analyte in the sample.

49. The method of claim 40, further comprising:
exciting the measurable species internal to a diffusion barrier layer; and
30 substantially excluding from excitation the measurable species external to the diffusion barrier layer.

50. A sensor strip, comprising:

a sensor base having at least two conductors under a dielectric layer, the at least two conductors being connected to at least two electrodes, at least one electrode having a diffusion barrier layer; and

a lid at least partially covering the sensor base, the lid forming a vent, the lid
5 having a concave area and an input end opening, and

wherein the sensor base and the lid form a cap-gap.

51. The sensor strip of claim 50, wherein the sensor base comprises a working electrode and a counter electrode, and wherein the working electrode has the diffusion barrier layer.

10 52. The sensor strip of claim 51, wherein the working and counter electrodes are in substantially the same plane

53. The sensor strip of claim 51, wherein the working and counter electrodes are separated by greater than 200 μm .

15 54. The sensor strip of claim 51, wherein the working and counter electrodes are separated from an upper portion of the lid by at least 100 μm .

55. The sensor strip of claim 51, wherein the counter electrode is configured to provide a reference potential.

56. The sensor strip of claim 51, wherein the dielectric layer partially covers the working and counter electrodes.

20 57. The sensor strip of claim 51, further comprising at least one reagent layer deposited on the conductors.

58. The sensor strip of claim 57, wherein the at least one reagent layer includes a reagent.

25 59. The sensor strip of claim 57, wherein the at least one reagent layer includes at least one of a binder and a mediator.

60. The sensor strip of claim 50, wherein the diffusion barrier layer is integral to a reagent layer.

61. The sensor strip of claim 60, wherein a combined diffusion barrier and reagent layer has an average thickness less than 30 μm .

30 62. The sensor strip of claim 50, wherein the diffusion barrier layer is distinct from a reagent layer.

63. The sensor strip of claim 62, wherein the reagent layer resides on at least one of the sensor base and lid.

64. The sensor strip of claim 62, wherein the diffusion barrier layer has an average thickness of at least 5 μm .

65. A measuring device for determining an analyte in a biological fluid, comprising:

5 at least two contacts;

a display; and

electrical circuitry establishing electrical communication between the at least two contacts and the display, the electrical circuitry including a processor in electrical communication with an electric charger and a computer readable storage medium,

10 wherein the processor is operable to implement a pulse sequence from the electric charger to the at least two contacts during a time period equal to or less than 180 seconds, the pulse sequence having at least three duty cycles, the duty cycle having an excitation at a substantially constant voltage, the duty cycle having a relaxation,

15 wherein the processor is operable to measure at least one current profile at the least two contacts, and

wherein the processor is operable to determine the analyte in the biological fluid in response to the at least one current profile.

1/12

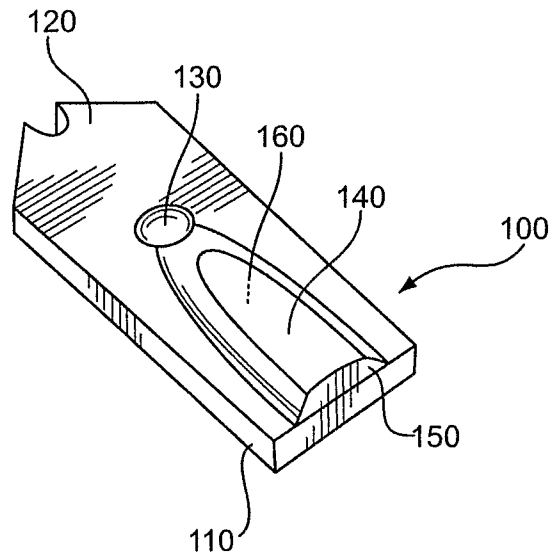

Fig. 1A

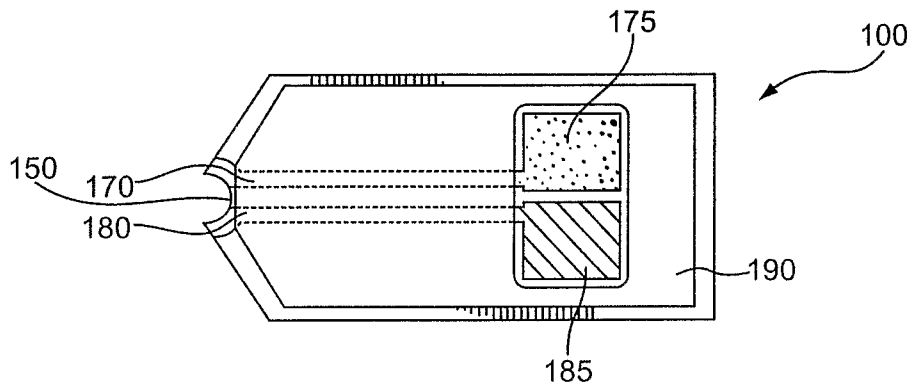

Fig. 1B

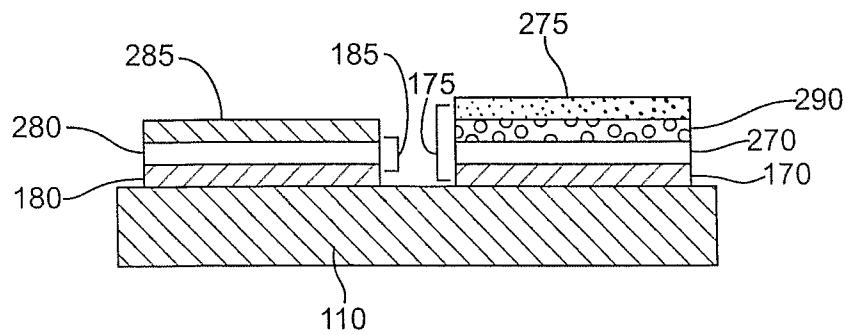

Fig. 2

2/12

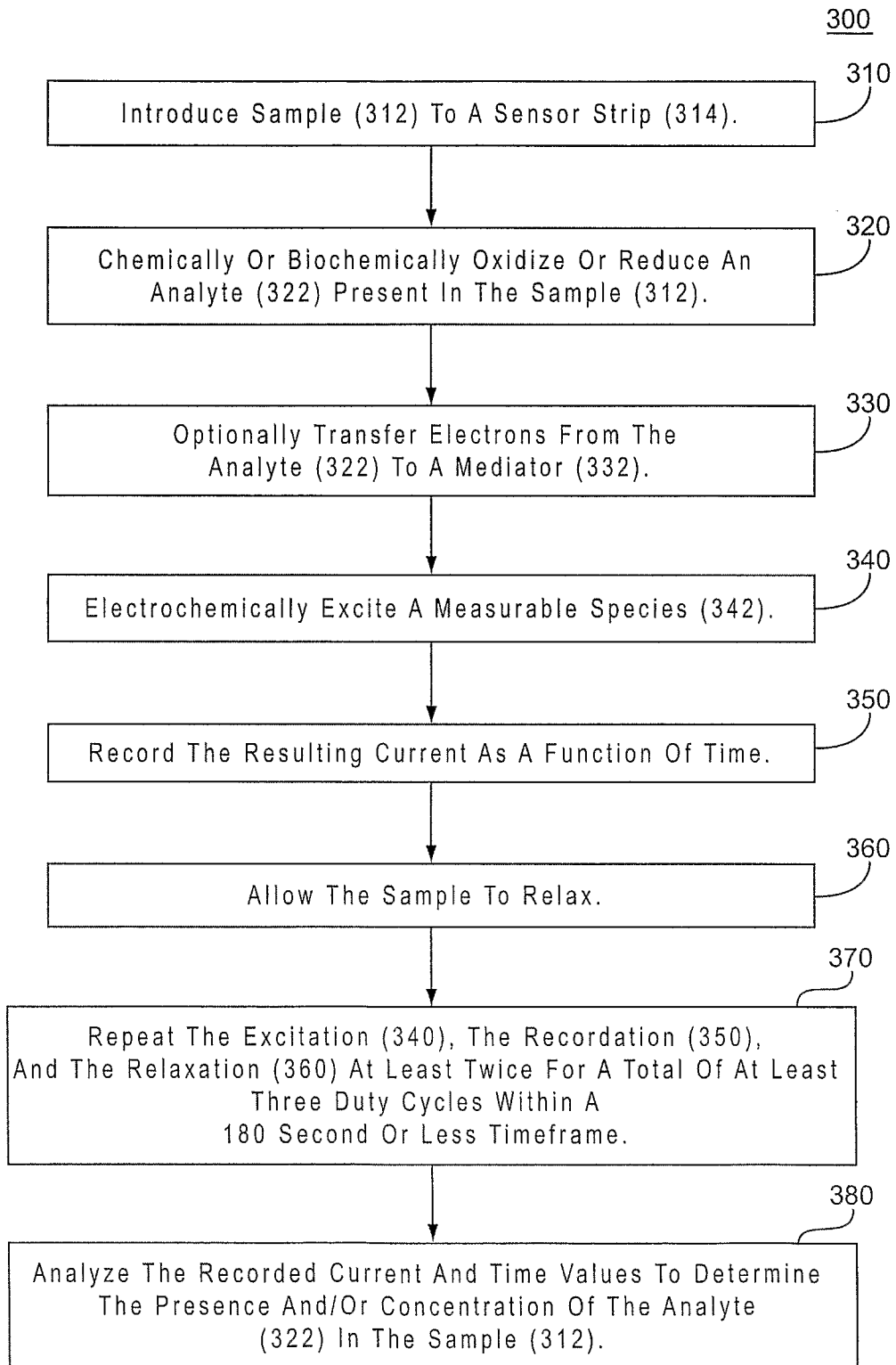

Fig.3

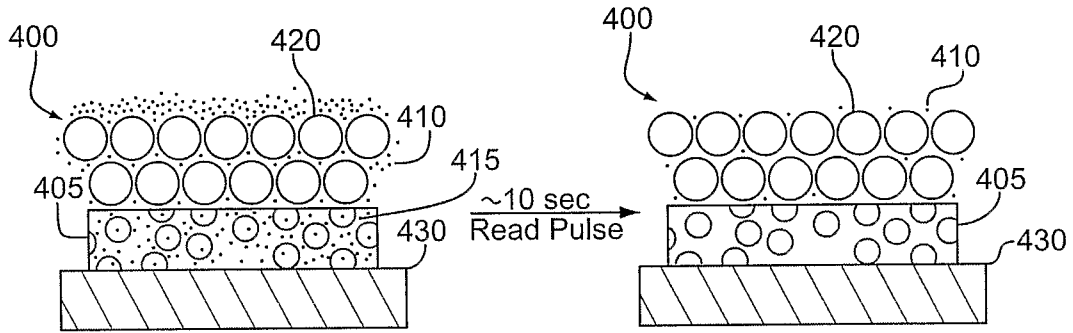

Fig.4A

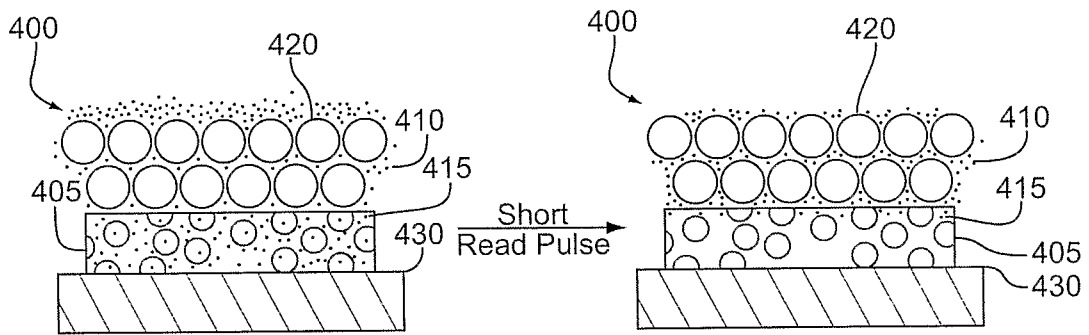

Fig.4B

4/12

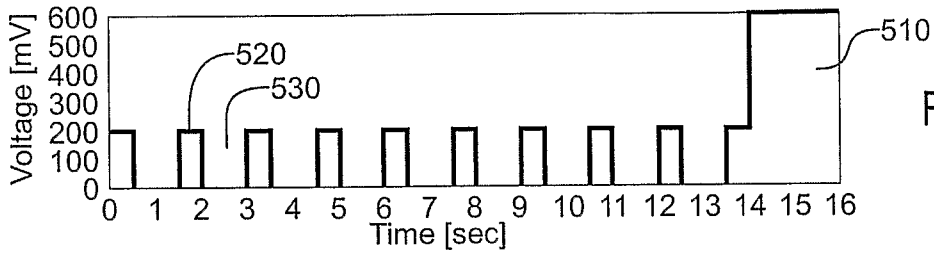

Fig. 5A

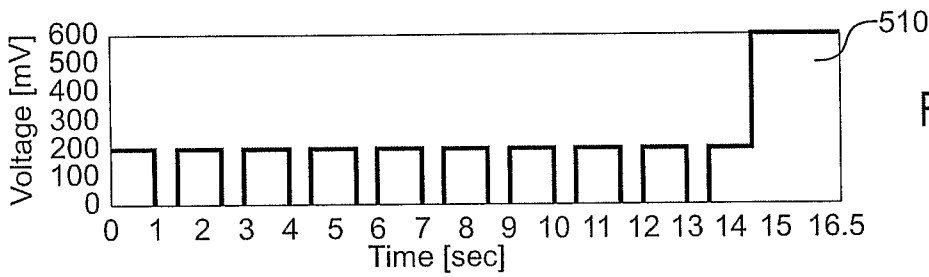

Fig. 5B

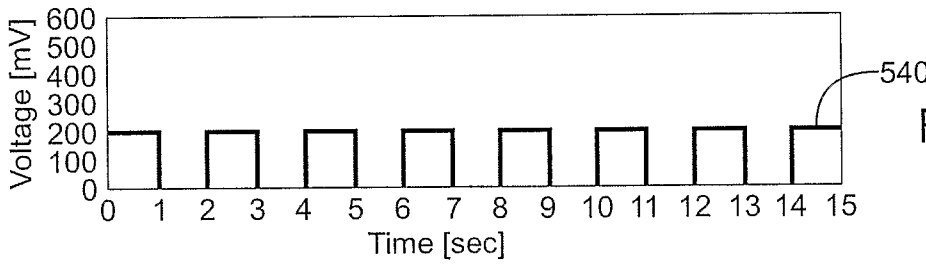

Fig. 5C

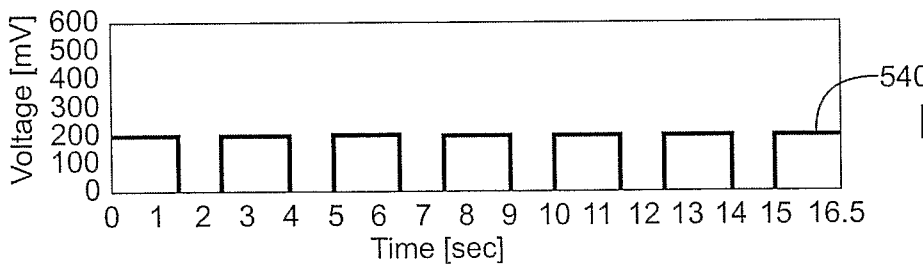

Fig. 5D

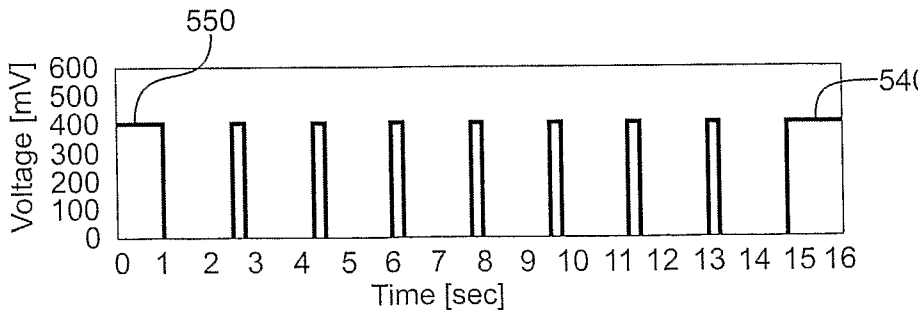

Fig. 5E

5/12

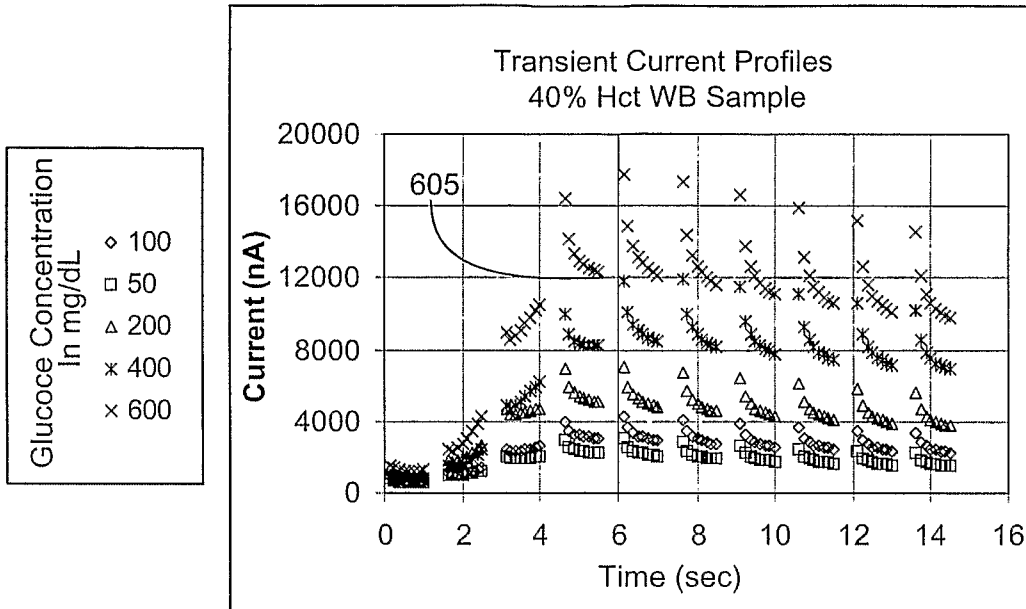

Fig.6A

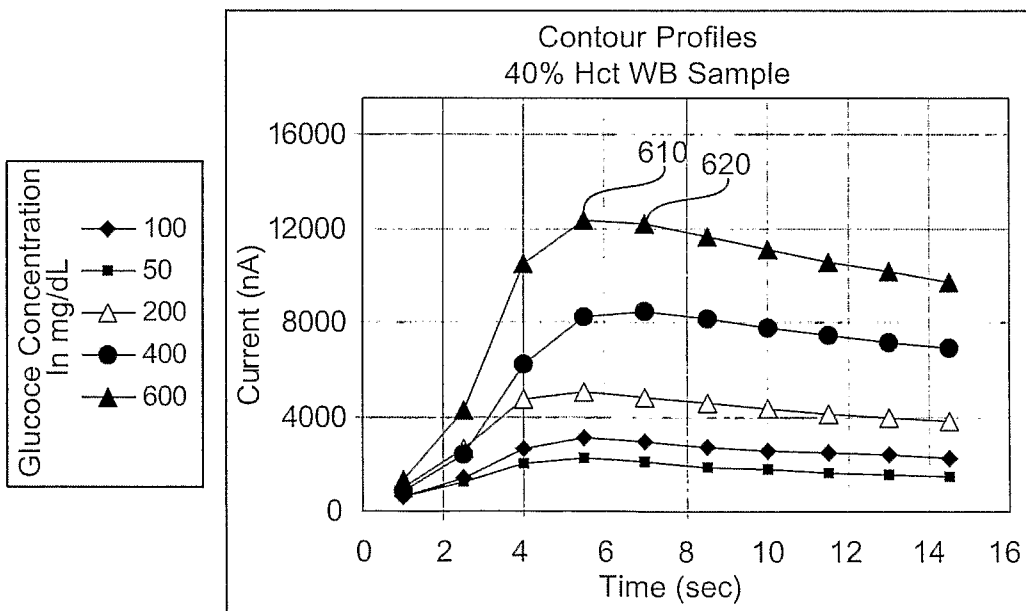

Fig.6B

6/12

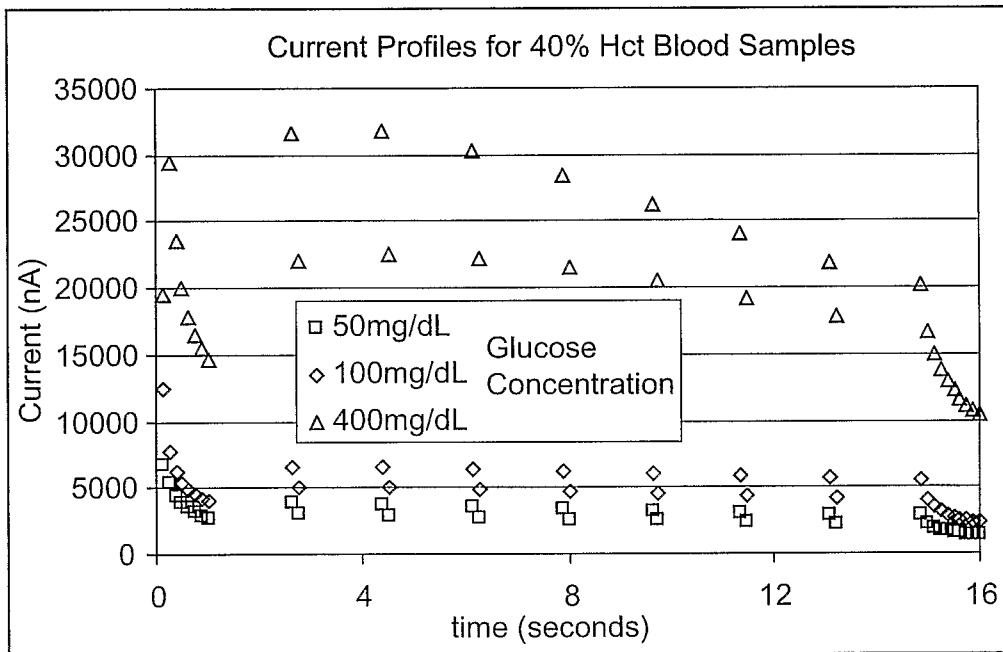

Fig.6C

7/12

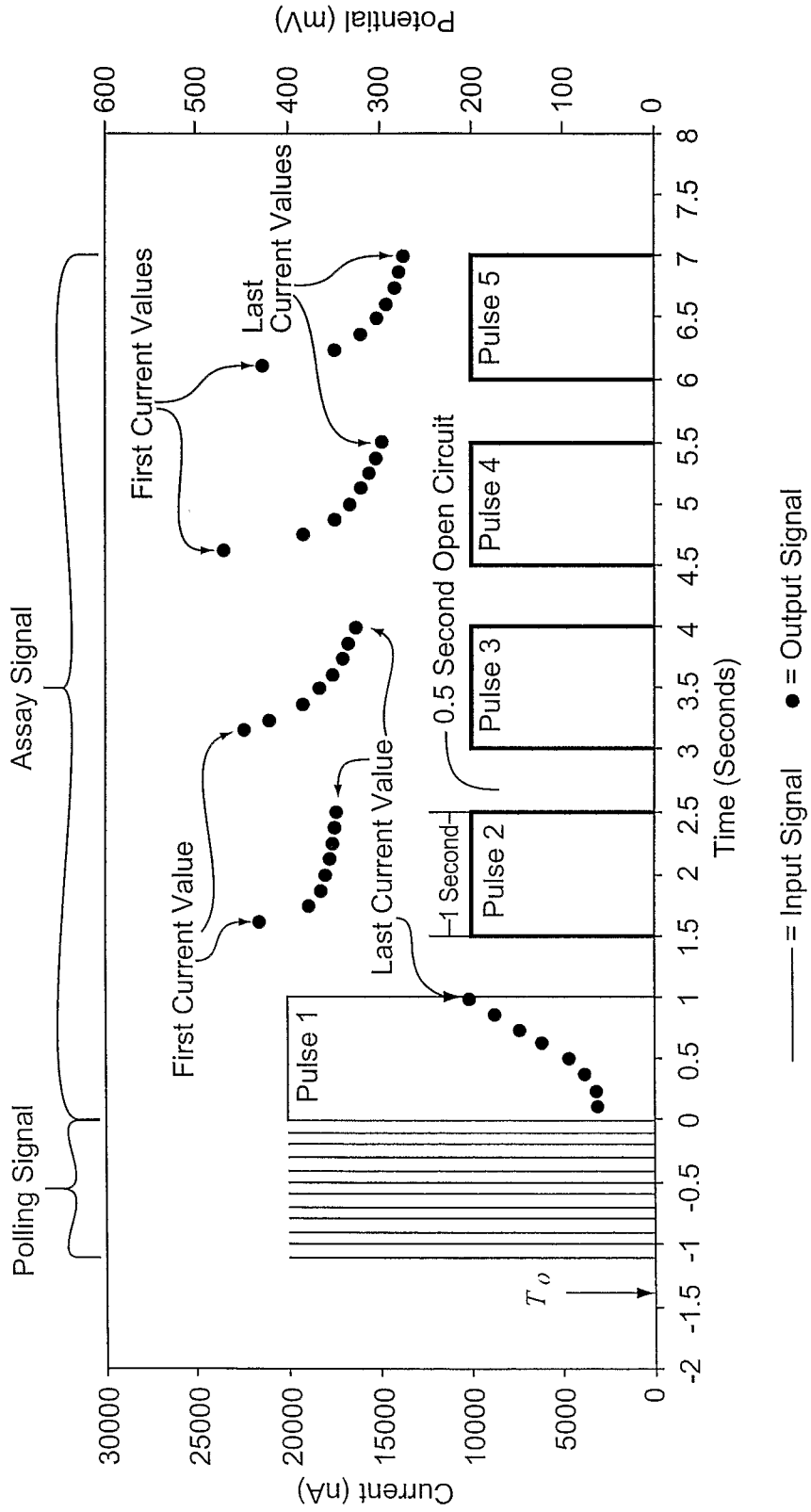

Fig. 6D

8/12

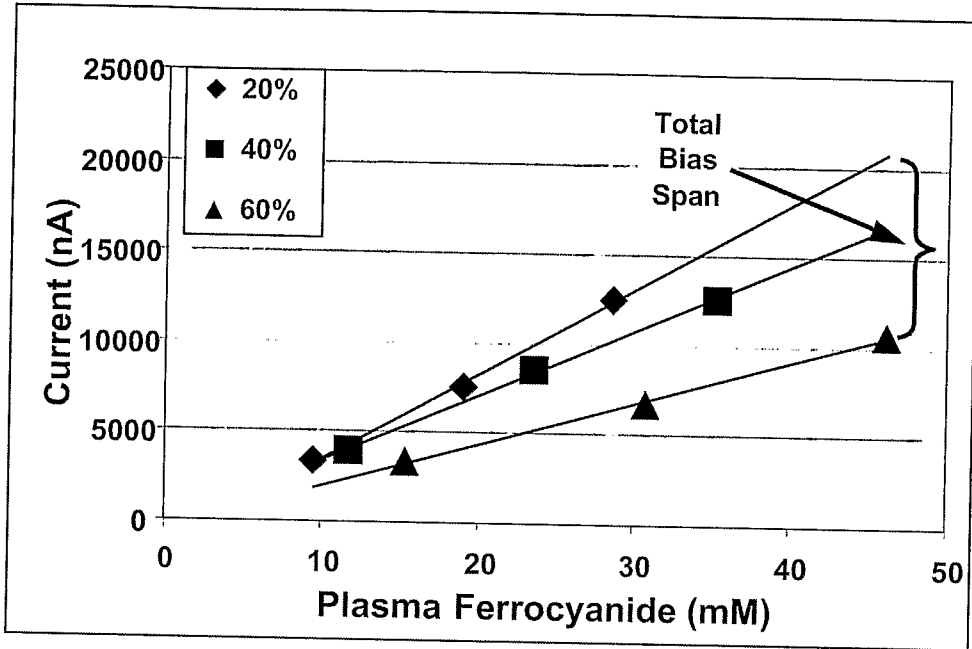

Fig.7A

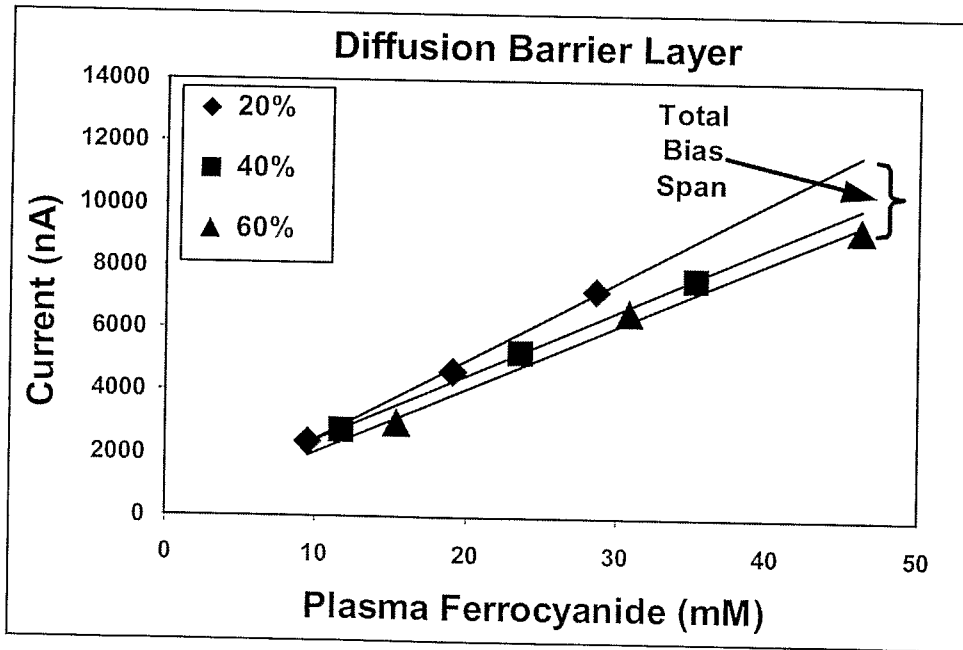

Fig.7B

9/12

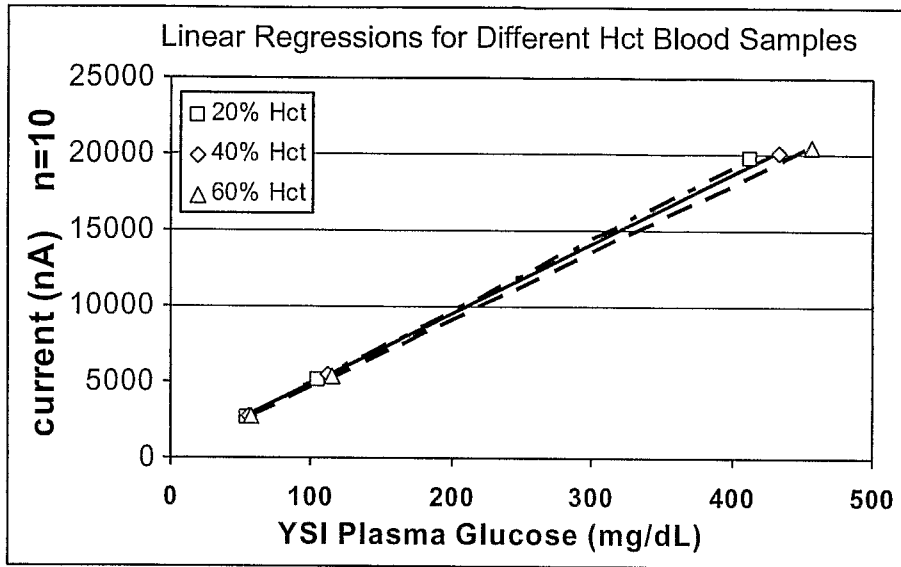

Fig.7C

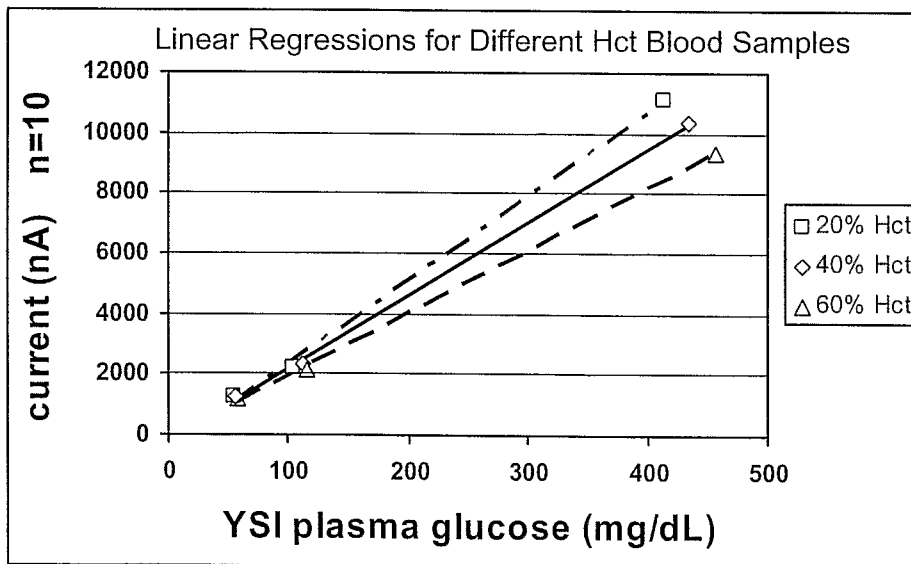

Fig.7D

10/12

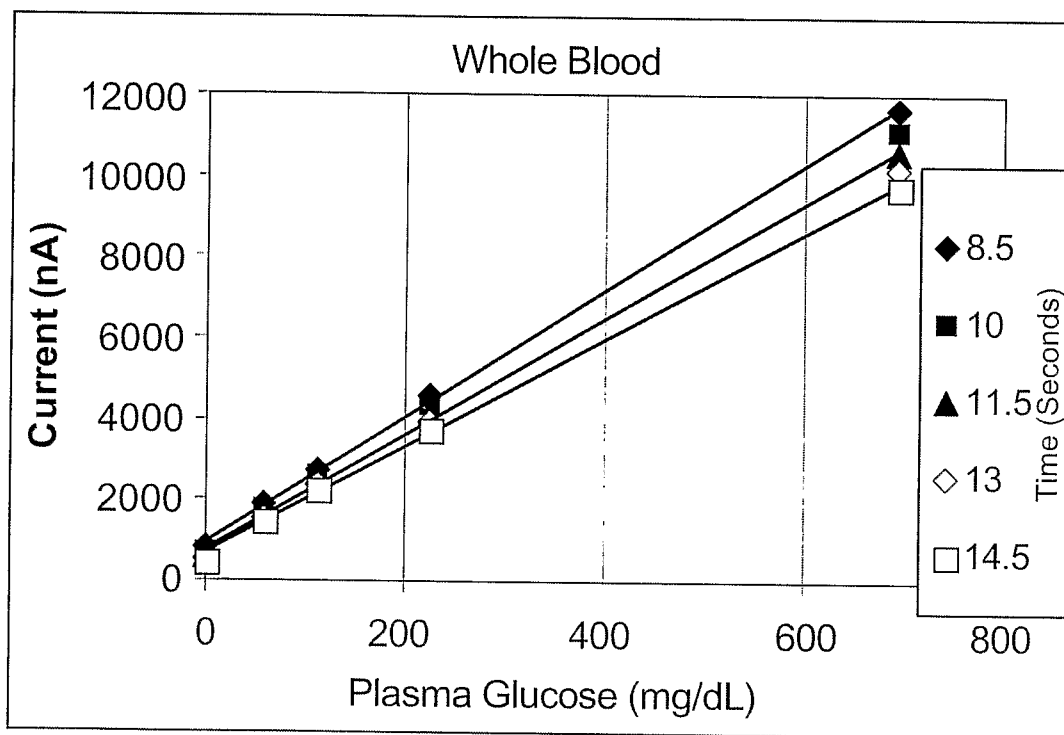

Fig.8

11/12

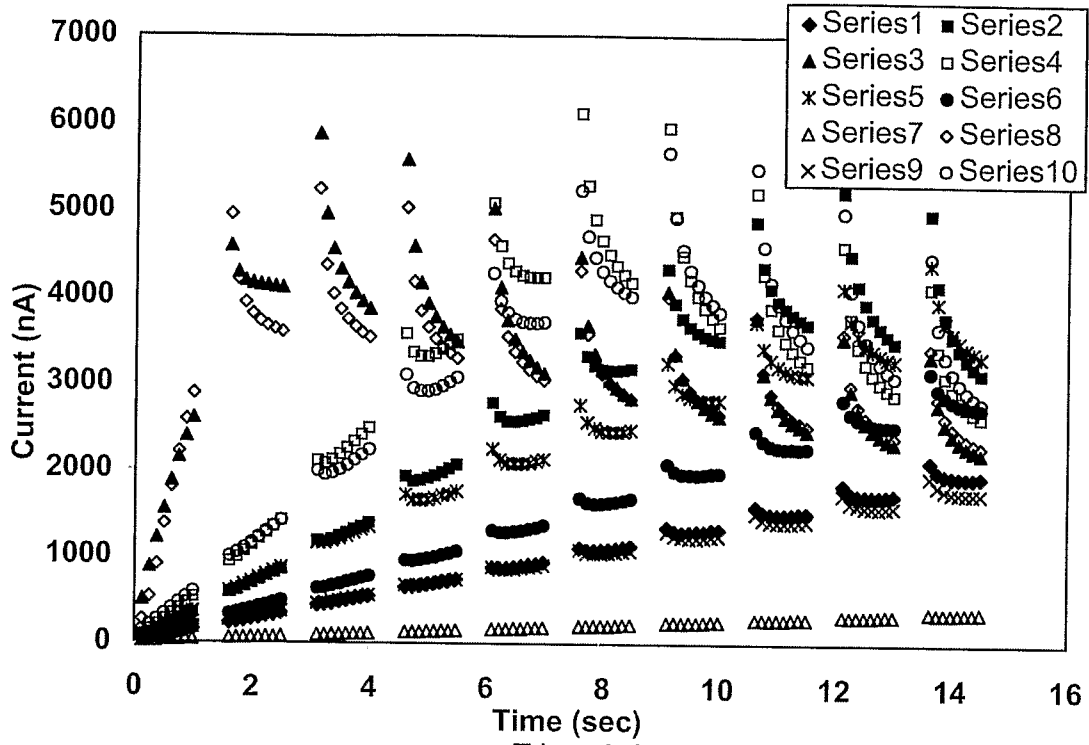

Fig.9A

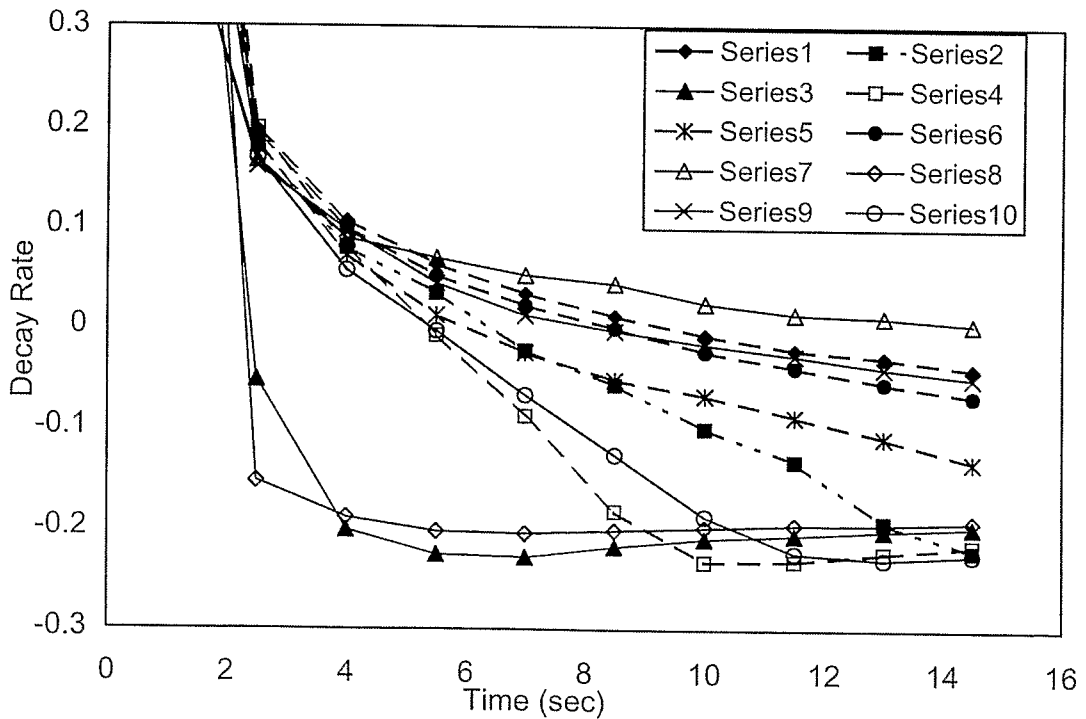

Fig.9B

12/12

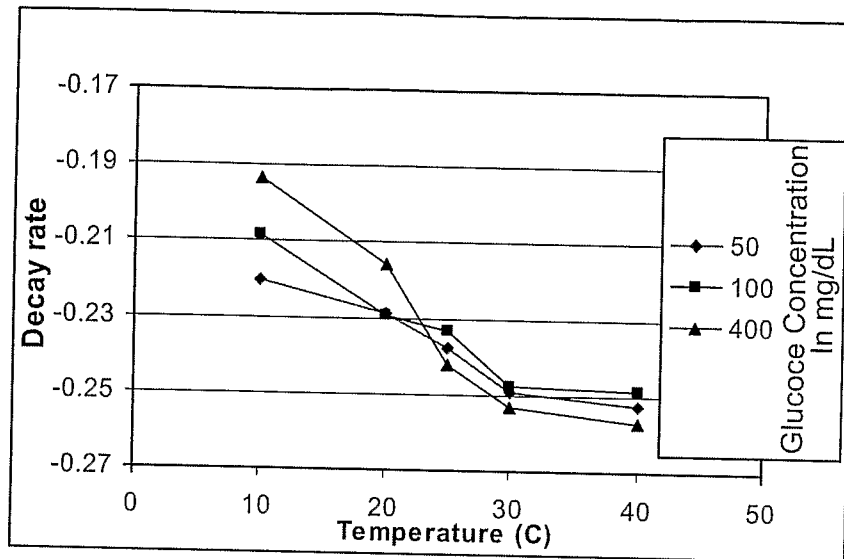

Fig.10

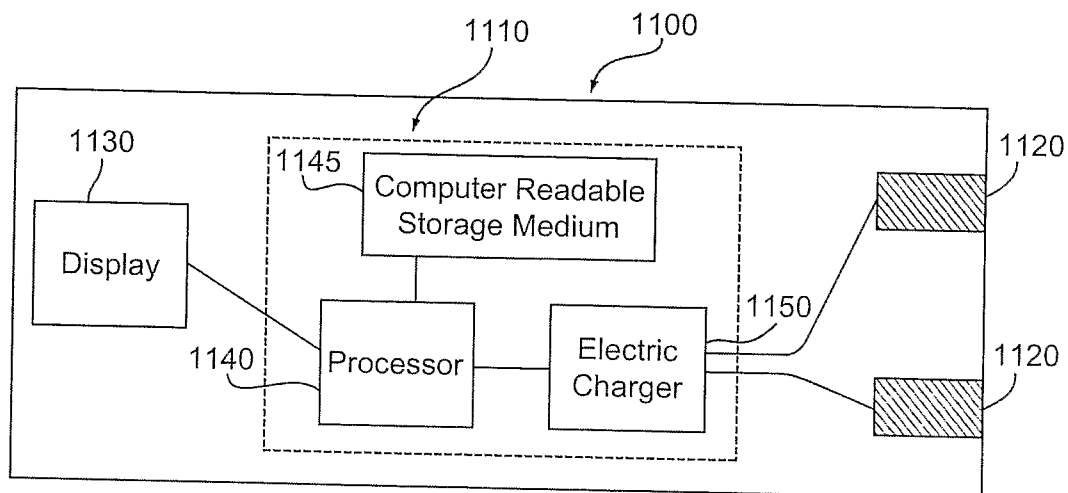

Fig.11

INTERNATIONAL SEARCH REPORT

International application No
PCT/US2006/028013

A. CLASSIFICATION OF SUBJECT MATTER
INV. G01N27/49 G01N33/487 C12Q1/00 A61B5/00

According to International Patent Classification (IPC) or to both national classification and IPC

B. FIELDS SEARCHED

Minimum documentation searched (classification system followed by classification symbols)
G01N C12Q A61B

Documentation searched other than minimum documentation to the extent that such documents are included in the fields searched

Electronic data base consulted during the international search (name of data base and, where practical, search terms used)

EPO-Internal, WPI Data, BIOSIS, EMBASE, INSPEC, COMPENDEX

C. DOCUMENTS CONSIDERED TO BE RELEVANT

Category*	Citation of document, with indication, where appropriate, of the relevant passages	Relevant to claim No.
P, X	WO 2006/042304 A (BAYER HEALTHCARE) 20 April 2006 (2006-04-20) cited in the application paragraph [0064] - paragraph [0106] paragraph [0111] - paragraph [0120] paragraph [0130] - paragraph [0139] figures 1, 2, 8-10B, 14A-15 ----- -/--	1-9, 18, 20, 24-32, 40-64

Further documents are listed in the continuation of Box C.

See patent family annex.

* Special categories of cited documents :

"A" document defining the general state of the art which is not considered to be of particular relevance

"E" earlier document but published on or after the international filing date

"L" document which may throw doubts on priority claim(s) or which is cited to establish the publication date of another citation or other special reason (as specified)

"O" document referring to an oral disclosure, use, exhibition or other means

"P" document published prior to the international filing date but later than the priority date claimed

"T" later document published after the international filing date or priority date and not in conflict with the application but cited to understand the principle or theory underlying the invention

"X" document of particular relevance; the claimed invention cannot be considered novel or cannot be considered to involve an inventive step when the document is taken alone

"Y" document of particular relevance; the claimed invention cannot be considered to involve an inventive step when the document is combined with one or more other such documents, such combination being obvious to a person skilled in the art.

"&" document member of the same patent family

Date of the actual completion of the international search

28 November 2006

Date of mailing of the international search report

06/12/2006

Name and mailing address of the ISA/

European Patent Office, P.B. 5818 Patentlaan 2
 NL - 2280 HV Rijswijk
 Tel. (+31-70) 340-2040, Tx. 31 651 epo nl,
 Fax: (+31-70) 340-3016

Authorized officer

Johnson, Keith

INTERNATIONAL SEARCH REPORT

International application No
PCT/US2006/028013

C(Continuation). DOCUMENTS CONSIDERED TO BE RELEVANT

Category*	Citation of document, with indication, where appropriate, of the relevant passages	Relevant to claim No.
X Y A	WO 98/58250 A2 (ELAN CORPORATION) 23 December 1998 (1998-12-23) page 18, line 2 - page 28, line 15 figures 1A,1B,4A-4C,5,7 -----	1-10,18, 20, 24-33, 35, 40-49,65 19 11-13, 17,21, 22,34, 37,50, 51,55, 57-59, 62,64
X Y A	WO 01/21827 A (ROCHE DIAGNOSTICS) 29 March 2001 (2001-03-29) page 3, line 1 - line 16 page 11, line 3 - page 14, line 29 figures 1-5,7,8,10; example 2 -----	17,65 19 1-11,18, 20-24, 26, 28-30, 32-35, 40-64
X	WO 96/14026 A (ELAN MEDICAL TECHNOLOGIES]) 17 May 1996 (1996-05-17) page 33, line 1 - page 39, line 10 figures 8-14 -----	1-10,18, 24-33, 40-49,65
X	GUNASINGHAM H ET AL: "Pulsed amperometric detection of glucose using a mediated enzyme electrode" JOURNAL OF ELECTROANALYTICAL CHEMISTRY AND INTERFACIAL ELECTROCHEMISTRY, vol. 287, no. 2, 25 July 1990 (1990-07-25), pages 349-362, XP002328306 ISSN 0022-0728 the whole document -----	1-7,9, 10,12, 18,20, 24-32, 40-49,65
X	US 2004/072158 A1 (HENKENS R W ET AL) 15 April 2004 (2004-04-15) paragraph [0265] - paragraph [0278] figure 7 ----- -/--	1,4,6-8, 18, 24-32, 40-49

INTERNATIONAL SEARCH REPORT

International application No
PCT/US2006/028013

C(Continuation). DOCUMENTS CONSIDERED TO BE RELEVANT		
Category*	Citation of document, with indication, where appropriate, of the relevant passages	Relevant to claim No.
X	US 5 798 031 A (CHARLTON S C ET AL) 25 August 1998 (1998-08-25) cited in the application column 2, line 45 - column 4, line 35 figure 1 -----	50-61,63

INTERNATIONAL SEARCH REPORT

Information on patent family members

International application No

PCT/US2006/028013

Patent document cited in search report		Publication date	Patent family member(s)	Publication date
WO 2006042304	A	20-04-2006	NONE	
WO 9858250	A2	23-12-1998	AU 8031898 A CA 2294610 A1 EP 0990151 A2 JP 2002505008 T TW 380046 B	04-01-1999 23-12-1998 05-04-2000 12-02-2002 21-01-2000
WO 0121827	A	29-03-2001	AU 7590300 A CA 2385842 A1 EP 1218532 A1 JP 3655587 B2 JP 2003510570 T	24-04-2001 29-03-2001 03-07-2002 02-06-2005 18-03-2003
WO 9614026	A	17-05-1996	AT 205686 T AU 693279 B2 AU 3880095 A CA 2204370 A1 DE 69522821 D1 DE 69522821 T2 EP 0789540 A1 IE 940865 A1 JP 10508518 T NZ 295458 A ZA 9509309 A	15-10-2001 25-06-1998 31-05-1996 17-05-1996 25-10-2001 11-04-2002 20-08-1997 15-05-1996 25-08-1998 29-04-1999 29-05-1996
US 2004072158	A1	15-04-2004	NONE	
US 5798031	A	25-08-1998	AT 293251 T AU 724236 B2 AU 6482198 A CA 2236132 A1 DE 69829707 D1 DE 69829707 T2 DK 878708 T3 EP 0878708 A1 ES 2241073 T3 JP 10318971 A NZ 329793 A TW 400433 B	15-04-2005 14-09-2000 12-11-1998 12-11-1998 19-05-2005 02-03-2006 11-07-2005 18-11-1998 16-10-2005 04-12-1998 25-11-1998 01-08-2000