

(19) World Intellectual Property Organization
International Bureau



(43) International Publication Date
25 April 2002 (25.04.2002)

PCT

(10) International Publication Number
WO 02/33197 A1

- (51) International Patent Classification⁷: **E04F 15/04**, 13/08
- (21) International Application Number: PCT/SE01/01159
- (22) International Filing Date: 23 May 2001 (23.05.2001)
- (25) Filing Language: English
- (26) Publication Language: English
- (30) Priority Data:
100 51 404.9 17 October 2000 (17.10.2000) DE
- (71) Applicant (for all designated States except US): **PERGO AB** [SE/SE]; Strandridaregatan 8, S-231 25 Trelleborg (SE).
- (72) Inventor; and
(75) Inventor/Applicant (for US only): **KÜLICK, Magnus** [SE/SE]; Mejerigatan 30, S-233 35 Vellinge (SE).
- (74) Agent: **STENBERG, Yngve**; c/o Perstorp AB, S-284 80 Perstorp (SE).
- (81) Designated States (national): AE, AG, AL, AM, AT, AU, AZ, BA, BB, BG, BR, BY, BZ, CA, CH, CN, CR, CU, CZ, DE, DK, DM, DZ, EE, ES, FI, GB, GD, GE, GH, GM, HR, HU, ID, IL, IN, IS, JP, KE, KG, KP, KR, KZ, LC, LK, LR, LS, LT, LU, LV, MA, MD, MG, MK, MN, MW, MX, MZ, NO, NZ, PL, PT, RO, RU, SD, SE, SG, SI, SK, SL, TJ, TM, TR, TT, TZ, UA, UG, US, UZ, VN, YU, ZA, ZW.
- (84) Designated States (regional): ARIPO patent (GH, GM, KE, LS, MW, MZ, SD, SL, SZ, TZ, UG, ZW), Eurasian patent (AM, AZ, BY, KG, KZ, MD, RU, TJ, TM), European patent (AT, BE, CH, CY, DE, DK, ES, FI, FR, GB, GR, IE, IT, LU, MC, NL, PT, SE, TR), OAPI patent (BF, BJ, CF, CG, CI, CM, GA, GN, GW, ML, MR, NE, SN, TD, TG).
- Published:**
— with international search report
- For two-letter codes and other abbreviations, refer to the "Guidance Notes on Codes and Abbreviations" appearing at the beginning of each regular issue of the PCT Gazette.*

(54) Title: FLOORING OR WALL PANEL PROVIDED WITH A SNAP-ACTION LOCKING MEANS

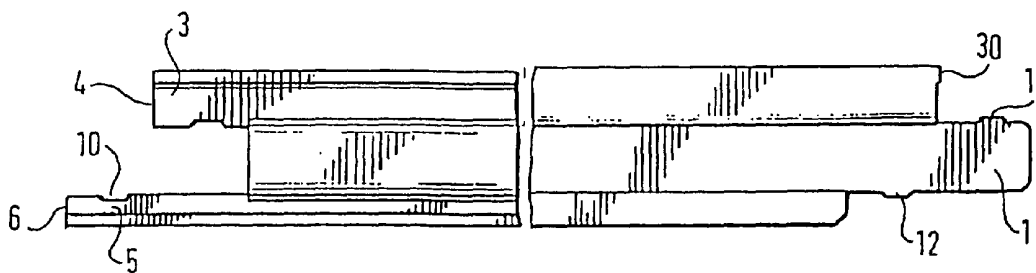

(57) Abstract: A flooring panel or wall panel (20) is provided with a tongue (1) and a groove (2) each comprising cooperating locking means in the form of ribs (11, 12) and grooves (9, 10). The locking means of the upper side and lower side of the tongue (1) and groove (2) respectively are arranged staggered in an insertion direction, in which the two panels to be joined to each other are joined, to configure a firm joint between two adjoining panels.



WO 02/33197 A1

Flooring or wall panel provided with a snap-action locking means.

The invention relates to a flooring panel or wall panel as set forth in the preamble of claim 1.

In recent years laminated floor finishes have become increasingly popular in replacing parquet floors and wall-to-wall carpeting. In the production of laminated floor finishes a decorative thermosetting laminate is first produced. This laminate usually consists of a base layer of paper sheets, impregnated with phenol-formaldehyde resin, and a decorative surface layer comprising a decor paper sheet impregnated with melamine formaldehyde resin. The laminate is produced by compressing the various layers at a high pressure and an elevated temperature. The laminate thus obtained may then be bonded to a backing, for example of particle board, or used as such without a backing, it then be termed a compact laminate. The resulting laminated panel of large surface area is then sawn up into a number of floor boards each provided with tongues and grooves at their long and short sides. These floor boards may differ in thickness and size, they more particularly being square or rectangular. A popular length is 120 cm, and a popular width is approx. 20 cm. Such laminated floor finishes may also be used to top existing floor material.

In laying such a floor finish an adhesive cement is usually applied to the groove when the floor boards are assembled. This makes it difficult to replace a board when damaged or to remove the complete floor finish and, for example, reinstalling it in another room.

Prior Art

DE 42 42 530 A1 describes a building element for walls or building floors and roofing which comprises at its longitudinal edge a tongue-like element and the opposing longitudinal edge a groove-like molding. The tongue-like element is configured strongly rounded suitable for insertion by jiggling it into the groove-like opening. Provided on one side of the tongue-like element are two ribs suitable for snap-action jointing a single groove of an adjoining building element. As it reads from this disclosure, however, a certain clearance needs to remain, thus resulting in this building element not at all being suitable for floor or wall finishes which for a pleasing appearance need to be joined free of clearance and accordingly with no gaps.

A wall panel or flooring panel as it reads from the preamble of claim 1 is known from WO 96/27721 of the present applicant. The flooring panel described therein comprises a tongue cooperating with a groove in an adjoining panel, the tongue comprising at least one snap-action means in the form of a rib oriented parallel to the edge of the panel. Configured in the groove at suitable locations for cooperating with the ribs of the tongue is a retaining or snap-action groove. It is these snap-action means that enable two adjoining panels to be joined without needing to use an adhesive cement. The one panel with its tongue is inserted into the groove of the adjoining panel, the so-called cheeks defining the groove deforming at least temporarily to permit entry of the rib formed on the tongue and regaining their original shape as soon as each rib has snapped into the corresponding groove. Experience has shown that although such flooring or wall panels permit reliable joining and placement without requiring an adhesive cement there is room for improvement in facilitating laying and the strength in joining the panels to each other.

Summary of the Invention

The invention is based on the object of providing a flooring panel or wall panel in which the snap-action or locking means are improved to facilitate laying and joining the panels whilst always attaining and maintaining a firm joint between adjoining panels.

This object is achieved by the flooring panel or wall panel as set forth in claim 1.

In accordance therewith the tongue of the panel in accordance with the invention too is provided with locking means. Provided at the opposite side of the panel is a groove into which the tongue of a panel is insertable when two adjoining panels are joined together. The tongue and the groove each comprise complementary snap-action or locking means. In this arrangement it is conceivable that both the tongue and the groove feature snap-action means in the form of ribs. The corresponding other element, i.e. either the tongue or the groove comprises a complementary snap-action means, i.e. a groove configured at a suitable location for each rib provided. As will be detailed later it is preferably within the scope of the invention that the tongue is provided with ribs. More particularly in a preferred embodiment ribs are configured on both the upper and lower side of the tongue, although it is just as conceivable to provide only one of these sides with a rib and the other side of the tongue with a

groove. Likewise basically conceivable is to configure a groove on both the upper and lower side of the tongue.

In any case, however, both the upper and lower side of the tongue is provided with a locking means for a flooring panel or wall panel in accordance with the invention, complementary locking means being provided correspondingly on the surface area defining the tongue both upper and lower. In accordance with the invention these locking means are arranged staggered in the insertion direction. Insertion direction in this context is understood to be the direction in which the tongue is inserted into the groove to join two adjoining panels to each other. The insertion direction thus extends perpendicular to the edge as observed of the panel. Staggering in the insertion direction means that one of the locking means is configured more distant from the edge of the panel than the other, in other words one of the locking means extends parallel to the edge of the panel at a greater distance away from this edge than the other locking means. It is to be noted that in accordance with the invention two or more locking means may be provided at the upper and/or lower side of the tongue and that corresponding locking means are configured on the groove. In this case, the staggered arrangement as described applies to at least one of the locking means provided at the side comprising more than one locking means.

Tests show that configuring the locking contours in accordance with the invention facilitates laying the flooring panels, more particularly in facilitating joining two adjoining flooring panels, it also having been found out that the joint thus resulting between two adjoining panels is extremely firm. The reason for this could be that due to the stagger, any movement of the two flooring panels joined together relative to each other is made difficult. When the locking means of both sides are located precisely opposite each other, jiggling the two flooring panels is easier possible when the locking means are staggered relative to each other and any movement "about" the one locking element by the other locking element is obstructed.

More particularly the tongue of the panel in accordance with the invention, unlike the tongue-like element pertinent to DE 42 42 530 A1, is configured with practically straight surface areas, i.e. bevels or roundings existing possibly only at the edges. Furthermore, unlike the connecting contour as it reads from the cited disclosure, a defined protuberance or a defined rib is provided on both sides of the tongue. In other words, a snap-acting or locking means, ensuring locking in the insertion direction, is not formed by a special contour of the tongue itself. In conclusion, it is to be noted

that in accordance with the invention all snap-acting means comprise complementary snap-acting means, so that when two ribs are provided, two corresponding grooves are also provided.

Preferred further embodiments of the panel in accordance with the invention read from the sub-claims.

Although a panel in accordance with the invention is conceivable in the form of a triangle with a groove or tongue configured on each side, the panel in accordance with the invention preferably has four sides and is more particularly rectangular or square: In this case two sides of the panel comprise tongues and two sides of the panel comprise grooves. It is understood that, as preferred, the panels may be configured identical and can be joined to each other in this way when the opposite side in each case is provided tongued and grooved so that two adjoining sides, in the case of a rectangular panel a short and a long side, are provided with tongues, and the two other sides with the complementary configured grooves.

As already mentioned it is preferred in the scope of the invention that the tongue comprises as a locking means at least one protuberance, more particularly a rib and that the locking means cooperating therewith in the groove are recesses, more particularly snap-action or locking grooves.

A particularly firm joint is achieved in the preferred embodiment in which two protuberances are configured on the upper side of the tongue and a protuberance as well as corresponding recesses or grooves in the groove are configured on the lower side.

The advantage of a firm joint is likewise achieved with the preferred embodiment in which the tongue comprises at the upper side a protuberance, preferably a rib and at the lower side two protuberances or ribs, and the groove is provided with corresponding snap-action grooves.

Damage to the cheeks defining the groove can be prevented when their edges end substantially at the same location, i.e. when, in other words, the edge of the upper cheek of the groove or lip is arranged substantially exactly over the edge of the lower cheek of the groove or lip.

It is good practice to configure the locking contours which are particularly prone to damage, so that the recess or groove in the lower cheek of the groove or lip is arranged at a location which is totally distal within the distal edge of the upper lip or cheek of the groove.

In certain applications, however, the lower cheek of the groove or lip preferably protrudes distally beyond the distal edge of the upper cheek of the groove or lip.

However, in this case too, it is good practice when the recess or groove in the lower cheek of the groove or lip is provided at a location totally, or at least substantially, within the distal edge of the upper lip or cheek of the groove.

In the embodiment featuring two ribs at the upper side of the tongue, too, it may be good practice in certain applications when the lower cheek of the groove or lip extends beyond the distal end of the upper lip.

In this case, another preferred embodiment consists of a recess or groove being provided in the lower cheek of the groove at a location which is totally on the other side of the distal edge of the upper cheek of the groove, and the other recess or groove is provided at a location which is totally within the distal edge of the upper cheek of the groove.

As an alternative, it has been discovered to be good practice in certain situations to configure a recess totally on the other side of the distal edge of the upper lip and to also configure the other recess totally, or substantially, on the other side of the distal edge of the upper lip

Another preferred embodiment which experience has shown to be of advantage as regards the strength of the joint consists of the edge of the upper cheek of the groove being located substantially precisely above the edge of the lower cheek of the groove, the tongue being provided at both its upper side and lower side with a protuberance and the recess in the lower cheek of the groove being provided at a location which is totally within the distal edge of the upper cheek of the groove.

In the same way another embodiment is of advantage in which the edge of the lower cheek of the groove protrudes distally beyond the distal edge of the upper cheek of the groove, the tongue being provided on both its upper and lower side with a

protuberance and the recess being provided in the lower cheek of the groove at a location which is totally, or at least partly, on the other side of the distal edge of the upper cheek of the groove.

As an alternative a firm joint is also obtainable - in the same case as described above - by providing the recess in the lower cheek of the groove at a location which is totally, or substantially totally, within the distal edge of the upper cheek of the groove.

For the materials of the flooring panel a structure comprising a base layer of particle board, medium or high density fiber board or plastics topped by a decor finish of paint or a thermoplastics, veneer or one or more sheets of paper impregnated with a thermosetting resin or laminate is of particular advantage.

For particularly cost-effective production of the panel in accordance with the invention it is good practice to configure the tongue and the groove as well as the snap-action means integrally with the base layer, in other words to mill the locking contours from the base layer.

When used in wet rooms it is good practice to configure the side edges comprising the tongue and groove water-tight.

For this purpose it is good practice to treat the base layer of the panel in accordance with the invention such that its resistance to water is enhanced.

More particularly, good performance of this embodiment is achievable by impregnating or coating the complete base layer or at least the side edges of the panel with a wax, an oil or a resin.

For a simple joint of two adjoining panels it is good practice to configure a front surface area of the tongue with its lower side tapered which may also be provided supplementary for the upper edge of the tongue. Likewise, the edges of the cheeks defining the groove may be configured bevelled or rounded.

One particularly advantageous feature applicable to the flooring panel or wall panel in accordance with the invention consists of the lower cheek of the groove being thinner than its upper cheek so that the lower cheek is more pliant than the upper cheek and is deformed to a greater extent than the upper cheek of the groove when joining two

adjoining panels. Preferably the upper cheek of the groove should not deform at all to eliminate the risk of steps forming when joining the panels together. Instead only the lower cheek of the groove should slightly deform on joining before snapping back into place for a secure lock. The comparatively thick and thus comparatively stiff upper cheek of the groove or lip also contributes towards maintaining the floor surface area flat once the panels have been joined and when accessed.

In conclusion it has found to be particularly of advantage in this case to configure the lower lip or cheek of the groove 50% to 90%, preferably 60% to 85% as thick as the upper cheek of the groove.

Brief Description of the Drawings

Embodiments of the invention will now be detailed by way of example with reference to the drawings in which:

- Fig. 1 is a plan view of the flooring panel or wall panel in accordance with the invention;
- Fig. 2 is a sectioned view through the flooring panel or wall panel in accordance with the invention in a first embodiment;
- Fig. 3 is a sectioned view through the flooring panel or wall panel in accordance with the invention in a second embodiment;
- Fig. 4 is a sectioned view through the flooring panel or wall panel in accordance with the invention in a third embodiment;
- Fig. 5 is a sectioned view through the flooring panel or wall panel in accordance with the invention in a fourth embodiment;
- Fig. 6 is a sectioned view through the flooring panel or wall panel in accordance with the invention in a fifth embodiment;
- Fig. 7 is a sectioned view through the flooring panel or wall panel in accordance with the invention in a sixth embodiment.

- Fig. 8 is a sectioned view through the flooring panel or wall panel in accordance with the invention in a seventh embodiment.
- Fig. 9 is a sectioned view through the flooring panel or wall panel in accordance with the invention in an eighth embodiment.
- Fig. 10 is a sectioned view through the flooring panel or wall panel in accordance with the invention in a ninth embodiment.

Detailed Description of Preferred Embodiments of the Invention

Referring now to Fig. 1 there is illustrated a plan view of the flooring panel or wall panel in accordance with the invention in which it is to be noted that to simplify the illustration only a few corner portions of the panel 20 are shown and that the panel may be dimensioned optionally between these corner portions as shown, it more particularly being shaped either square or rectangular. Configured at the (longer) longitudinal edges of the embodiment of the panel 20 as shown is on the one side (on the left in Fig. 1) a tongue 1 and on the opposite side a groove. Likewise on the lower short side as shown in Fig. 1 a tongue 1 is configured with a groove provided on the opposite short side. It is obvious that due to this configuration panels of the same kind can be joined together to form a complete floor finish. It is to be noted that the tongue 1 and the locking means as to be later described are configured continuous and full-length in each of the preferred embodiments, although it is just as conceivable to configure both the tongue 1 and the locking means discontinuous. In conclusion it is to be noted as regards Fig. 1 that it shows a plan view of a preferred embodiment in which - as evident from Fig. 2 for example - the lower cheek of the groove protrudes beyond the edge of the upper cheek of the groove, this being the reason why two lines are evident at the top right-hand edge of the illustration in Fig. 1, although, of course, only one line would be present for example in the case of the embodiment as shown in Fig. 5 since in this case the two cheeks of the groove end substantially at the same level.

Referring now to Fig. 2 there is illustrated an embodiment of the locking means of the flooring or wall panel 20 in accordance with the invention. For one thing, the protruding tongue 1 comprises at both its upper side and lower side a protuberance or rib 11 and 12 respectively. The two ribs are configured staggered, i.e. differinglly

spaced away from the edge 22 of the tongue 1. For locking to a panel of the same kind a groove 2 is configured in the opposite side defined by two cheeks or lips 3 and 5 respectively. Snap-action grooves 9 and 10 respectively are provided in each of the two lips 3, 5. The position of these snap-action or locking grooves 9, 10 is complementary to the position of the ribs 11 and 12 on the upper side 7 and lower side 8 of the tongue 1 to thus enable two panels of the same kind to be locked together. The locking action results from, for example, the spacing between the edge 24 of the panel 20 above the tongue 1 and the rear flank 26 of the rib 11 being slightly smaller than the spacing between the front edge 4 of the upper cheek 3 of the groove and the front flank 28 of the locking groove 9. Likewise the relationships for the lower rib and the corresponding groove may be set such that, here too, a firm snap-action joint materializes to lock two adjoining panels to each other.

The contour as described is configured preferably on all opposite sides, i.e. on each longitudinal side and short side to ensure locking at all edges. For this purpose the tongue 1 on each panel 20 is inserted into the groove of an adjoining panel until the ribs 11, 12 snap into place in the grooves 9, 10. More particularly a firm joint, in which also any tendency of the two adjoining panels to tilt is effectively prevented, is achieved in that to a certain extent to the front of the rear lock in the form of the rib 12 and groove 10 a further lock in the form of the rib 11 in the groove 9 is provided which enhances stability, especially in preventing tilting.

Referring now to Fig. 3 there is illustrated how this effect is also achieved in the embodiment as shown therein, in which two ribs 12 are provided on the lower side of the tongue 1, and the lower cheek 5 of the groove correspondingly features two locking grooves 10. In this embodiment as shown in Fig. 3 too, at least one of the two ribs, namely the rear rib 12, is staggered relative to the upper rib 11 to achieve the advantages in accordance with the invention. The embodiment as shown in Fig. 3 further indicates how the lower cheek 5 of the groove is significantly thinner than the upper cheek 3 thereof so that when locking two panels together, it is substantially only the lower cheek 5 that is deformed with no risk of the upper cheek 3 being deformed. This additionally ensures a stable surface of the floor finish when laid. It is further to be understood as regards locking the two adjoining panels together that when inserting the tongue 1 the lower and, where necessary, also the upper cheek of the groove need to give to make room for the "extra-thick" ribs 11, 12. Once the ribs 11, 12 are located in the corresponding grooves 9, 10 the lower and/or upper cheek of the groove return to their original position. In the embodiment as shown in Fig. 3 there is a further

special feature provided in that a small protuberance or a nose 30 is configured on the panel above the tongue 1 to ensure a defined contact of the upper edge of the panel 20 with the upper edge of an adjoining panel to thus effectively prevent gaps forming whilst achieving a particularly rugged joint. It is to be noted that the nose 30 may be provided alternatively or additionally at the front edge 4 on the groove side.

As regards the thinner configuration of the lower cheek 5 of the groove and providing a nose 30, the embodiment as shown in Fig. 4 agrees with the embodiment as shown in Fig. 3. However, in the embodiment as shown in Fig. 4, the same as in the embodiment as shown in Fig. 2, a rib 11 and 12 respectively is provided at the upper and lower side of the tongue 1, here, however, more staggered than in the embodiment as shown in Fig. 2 so that the snap-action groove 10 configured in the lower cheek 5 of the groove is located totally on the other side of the front edge 4 of the upper cheek 3 of the groove. This configuration makes for a particularly long leverage in locking two adjoining panels together to thus achieve a joint safe from tilting.

Referring now to Fig. 5 there is illustrated an embodiment in which this applies likewise, in materializing substantially from the embodiment as shown in Fig. 4, in that in addition to the lower rib 12, staggered relatively far inwards, an additional, lower rib 12' is provided which is likewise configured staggered from the upper rib 11. The corresponding grooves 10, 10' are located at complementary locations. More particularly, in the embodiment as shown, both locking grooves 10, 10' are configured on the far side of the front or distal edge 4 of the upper cheek 3 of the groove.

Referring now to Fig. 6 there is illustrated an embodiment which agrees to a major extent with that as shown in Fig. 2, except that, here too, a nose 30 is configured. Furthermore, the lower side 8 of the tongue 1 is provided in the front portion with a bevel 32 to facilitate inserting the tongue 1 into the groove 2. In addition, in this case, the walls defining the two locking grooves 9 and 10 are configured vertical or near vertical. It is this configuration together with the slight inclination of the flanks of the ribs 11 and 12 that facilitates jiggling two panels relative to each other when joined which may be of advantage when dismantling the panels for installation in another room. This facility is further enhanced by the bevel 32 provided on the tongue 1 as well as by the rounded configuration 34 of each inner edge of the cheeks 3 and 5 of the groove.

Referring now to Fig. 7 there is illustrated yet another embodiment of the panel in accordance with the invention in which the front edge 4 of the upper cheek 3 of the groove is located substantially precisely above the front edge 6 of the lower cheek 5 of the groove. Provided furthermore in this case on both inner edges of the cheeks 3 and 5 of the groove are bevels 38 which as regards their function correspond to that of the roundings 34 in the embodiment as shown in Fig. 6, this more particularly facilitating inserting the tongue 1 into the groove 2 and dismantling two panels joined to each other. This is also promoted by the fact that the tongue 1 is provided with a bevel 32 not only at its lower side 8 but also by its upper side 7 featuring a somewhat less steeper bevel 32. A particularly firm joint and defined contact of the two panels with each other is achieved in that a nose 30 is provided on both the groove side and the tongue side. In conclusion the flanks too of the ribs 11 and 12 are bevelled. More particularly the front flanks are provided with a comparatively flat bevel 40 to facilitate their insertion into the grooves 9 and 10 respectively. The bevel at the rear flank is configured as the somewhat steeper bevel 42 and may be more particularly complementary to a corresponding bevel 44 at the front flank of the corresponding grooves 9, 10. As evident from Fig. 7 the locking means in the form of ribs and grooves are likewise staggered in this case which is of advantage for a firm joint.

Referring now to Fig. 8 there is illustrated an embodiment materializing substantially from the embodiment as shown in Fig. 7, except that in this case a nose 30 is provided only at the groove side. In addition, a second snap-action rib 11' is provided at the upper side of the tongue 1 configured substantially the same as the first upper snap-action rib 11. In this arrangement the bevel 40 of the snap-action rib 11' translates into a bevel provided in all at the tongue 1. Accordingly, it could be said as regards the embodiment as shown in Fig. 1 that at the upper side of the tongue 1 two snap-action grooves 46, 46' are provided instead of locking ribs 11, 11'. Thus the locking contour at the groove side could be viewed as being two locking ribs 48, 48' instead of two locking grooves 9, 9', for snap-action insertion into the locking grooves 46, 46' of the tongue 1. However, looking at it in this way changes nothing to the fact that complete snap-action or locking means are provided at the groove 2 and tongue 1, these means being configured at the upper side so that they are staggered relative to the locking rib 12 and the corresponding locking groove 10 to result in a strong joint.

Referring now to Fig. 9 there is illustrated the same aspect as selected in Fig. 2, by which the lower cheek 5 of the groove extends beyond the distal edge 4 of the upper cheek 3 of the groove. This permits achieving a greater stagger of the locking grooves

9 and 10 and correspondingly of the locking ribs 11 and 12, too. The remaining configuration of the locking ribs and grooves corresponds substantially to that as shown in Fig. 7, except that the tongue 1 is configured at its upper edge not bevelled, but rounded.

Referring now to Fig. 10 there is illustrated an embodiment which combines the aspects of the embodiments as shown in Figs. 8 and 9. More particularly, the lower cheek 5 of the groove extends beyond the front edge 4 of the upper cheek 3 of the groove. Configured in the upper cheek 3 of the groove are two locking grooves 9, 9', both of which are staggered relative to the lower locking groove 10. A corresponding configuration materializes for the locking ribs 11, 11' and 12 at the tongue 1. In this embodiment too, a particularly firm joint is achievable between adjoining panels.

It is further to be noted as regards the Figs. 7 to 10 that the preferred configuration of the panel 20 in accordance with the invention is particularly well evident. Integrally configured in a base layer 13 are the locking contours in the form of the tongue 1 and groove 2, it being on the base layer 13 that a decorative surface 14 is applied for which the materials as cited above may be selected.

Patent Claims

1. A flooring panel or wall panel (20) having at least three side edges provided with a locking means in the form of a tongue (1) and/or a groove (2), said groove (2) comprising an upper cheek (3) adjointly arranged above and at the upper side of said groove (2) and ending at a distal edge (4) of said upper cheek of the groove and a lower cheek (5) adjointly arranged below and at the lower side of said groove (2) and ending at a distal edge (6) of said lower cheek of said groove, said tongue (1) comprising an upper side (7) and a lower side (8), the surface area of said upper cheek (3) and of said lower cheek (5) each facing said groove (2) being provided with at least one snap-action means (9, 9', 10) and said upper side (7) and lower side (8) of said tongue (1) being provided with at least one complementary snap-action means (11, 11', 12), said snap-action means comprising a protuberance forming a snap-action rib and a recess forming a snap-action groove **characterized in that** relative to an insertion direction in which two panels of the same kind are joined, said snap-action means (9, 9' 10, 11, 11', 12) are staggered relative to each other and configured such that they force adjoining panels to form a tight joint when said tongues (1) snap into place in said grooves (2).
2. The panel as set forth in claim 1, characterized in that said panel has four sides, two of which comprise tongues (1) and the other two comprise grooves (2).
3. The panel as set forth in claim 1 or 2, characterized in that said snap-action means (11, 11', 12) at said tongue (1) consist of protuberances and said snap-action means (9, 9', 10) cooperating therewith consist of recesses at said cheeks (3, 5) of said groove (2).
4. The panel as set forth in claim 3, characterized in that said tongue (1) is provided with two protuberances on its upper side (7) and a protuberance on its lower side (8), and corresponding recesses cooperating therewith are configured at the cheeks (3, 5) of said groove (2).
5. The panel as set forth in claim 3, characterized in that said tongue (1) is provided with a protuberance on its upper side (7) and two protuberances on its lower side (8), and corresponding recesses cooperating therewith are configured at the cheeks (3, 5) of said groove (2).

6. The panel as set forth in claim 4, characterized in that said edge (4) of said upper cheek (3) of said groove is arranged precisely or substantially straight above said edge (6) of said lower cheek (5) of said groove.

7. The panel as set forth in claim 6, characterized in that said recess in said lower cheek (5) of said groove is arranged at a location which is distally totally within said distal edge (4) of said upper cheek (3) of said groove.

8. The panel as set forth in claim 4, characterized in that said lower cheek (5) of said groove extends distally beyond said distal edge (4) of said upper cheek (3) of said groove.

9. The panel as set forth in claim 8, characterized in that said recess in said lower cheek (5) of said groove is arranged at a location which is totally or substantially totally within said distal edge (4) of said upper cheek (3) of said groove.

10. The panel as set forth in claim 5, characterized in that said lower cheek (5) of said groove extends distally beyond said distal edge (4) of said upper cheek (3) of said groove.

11. The panel as set forth in claim 10, characterized in that said one recess in said lower cheek (5) of said groove is arranged at a location which is totally or substantially totally on the other side of said distal edge (4) of said upper cheek of said groove, and the other recess is arranged at a location which is totally or substantially totally within said distal edge (4) of said upper cheek (3) of said groove.

12. The panel as set forth in claim 10, characterized in that said one recess in said lower cheek (5) of said groove is arranged at a location which is totally or substantially totally on the other side of said distal edge (4) of said upper cheek of said groove, and the other recess is arranged at a location which is totally or substantially totally on the other side of said distal edge (4) of said upper cheek of said groove.

13. The panel as set forth in claim 3, characterized in that said edge (4) of said upper cheek (3) of said groove is arranged precisely or substantially straight above said edge (6) of said lower cheek (5) of said groove, said tongue (1) being provided with a protuberance at its upper side (7) and a protuberance at its lower side (8) and said

recess in said lower cheek (5) of said groove is arranged at a location which is totally or substantially totally within said distal edge (4) of said upper cheek of said groove.

14. The panel as set forth in claim 3, characterized in that said edge (6) of said lower cheek of said groove extends distally beyond said edge (4) of said upper cheek (3) of said groove, said tongue (1) being provided with a protuberance at its upper side (7) and a protuberance at its lower side (8) and said recess in said lower cheek (5) of said groove is arranged at a location which is totally or at least partially on the other side of said distal edge (4) of said upper cheek of said groove.

15. The panel as set forth in claim 3, characterized in that said edge (6) of said lower cheek of said groove extends distally beyond said edge (4) of said upper cheek of said groove, said tongue (1) being provided with a protuberance at its upper side (7) and a protuberance at its lower side (8) and said recess in said lower cheek (5) of said groove is arranged at a location which is totally or substantially totally within said distal edge (4) of said upper cheek of said groove.

16. The panel as set forth in any of the claims 1 to 15, characterized in that said panel comprises a base layer (13) of particle board, medium or high density fiber board or plastics topped by a decor finish (14) of paint or a thermoplastics, veneer or one or more layers of paper impregnated with a thermosetting resin or laminate.

17. The panel as set forth in any of the preceding claims, characterized in that said tongue (1) and said groove (2) as well as said snap-action means (9, 9', 10, 11, 11', 12) are configured integrally with said base layer (13).

18. The panel as set forth in claim 16, characterized in that the side edges with said groove (2) and tongue (1) are water-tight.

19. The panel as set forth in claim 18, characterized in that said base layer (13) is treated such that said water-tightness is enhanced.

20. The panel as set forth in claim 19, characterized in that said complete base layer (13) or only said side edges of said panel are impregnated or coated with a wax, an oil or a resin.

21. The panel as set forth in any of the preceding claims, characterized in that said tongue (1) comprises a bevelled lower front surface area (32).

22. The panel as set forth in any of the preceding claims, characterized in that said lower cheek (5) is thinner than said upper cheek (3) of said groove.

23. The panel as set forth in claim 22, characterized in that the thickness of said lower cheek (5) is 50% to 90%, preferably 60% to 85% of the thickness of said upper cheek (3) of said groove.

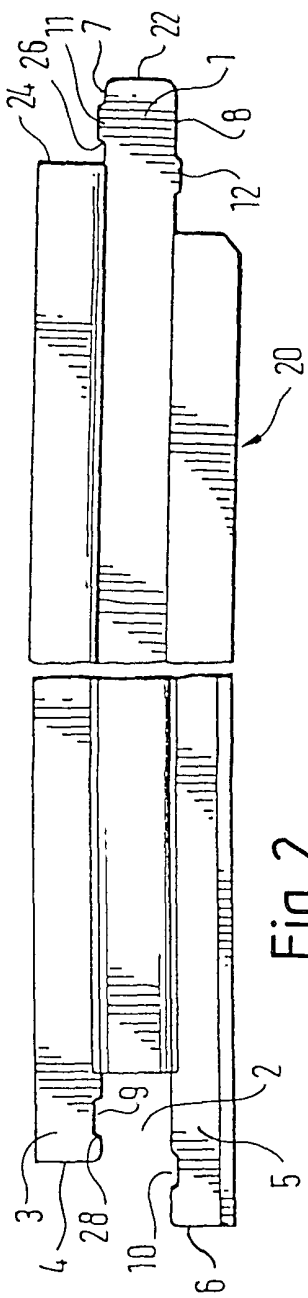
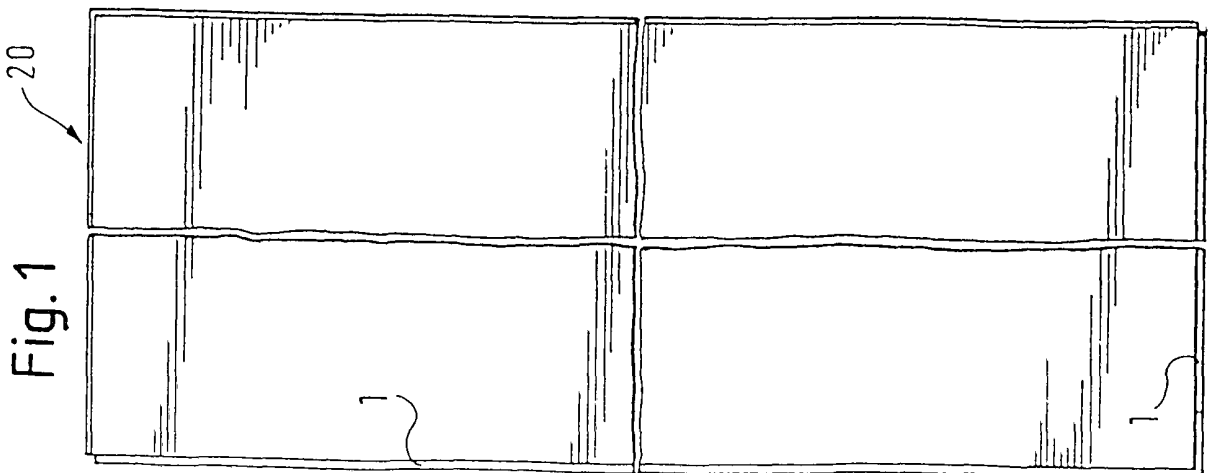

Fig. 2

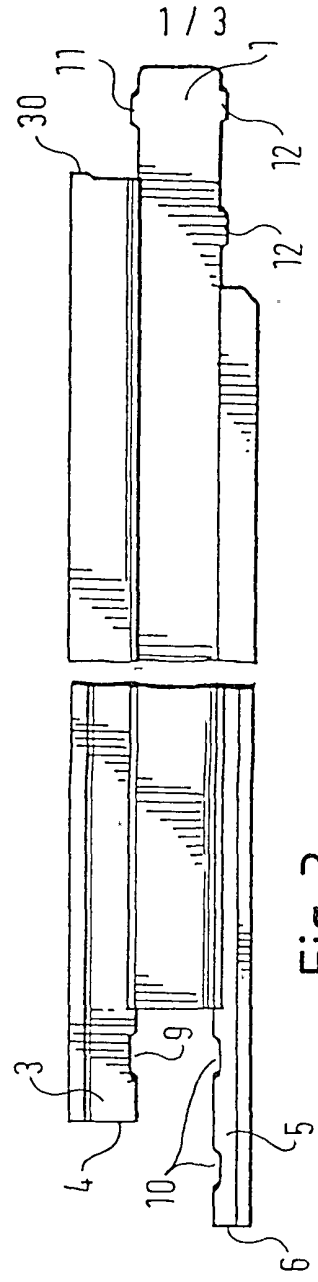

Fig. 3

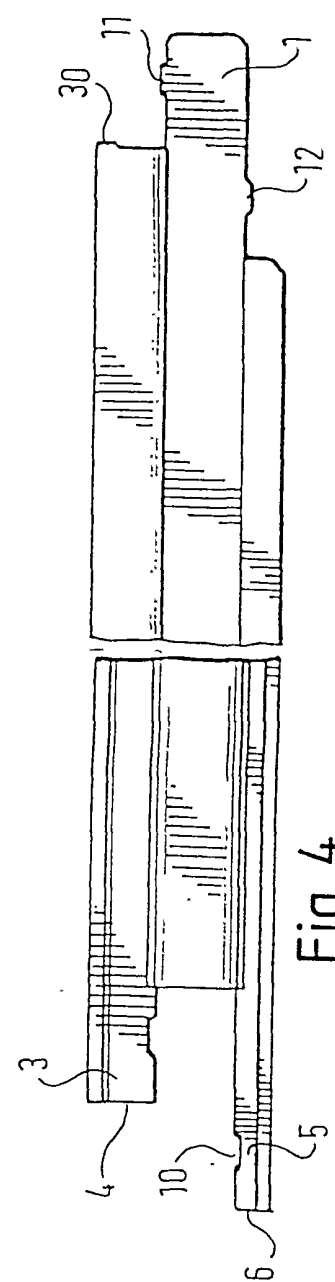

Fig. 4

Fig. 5

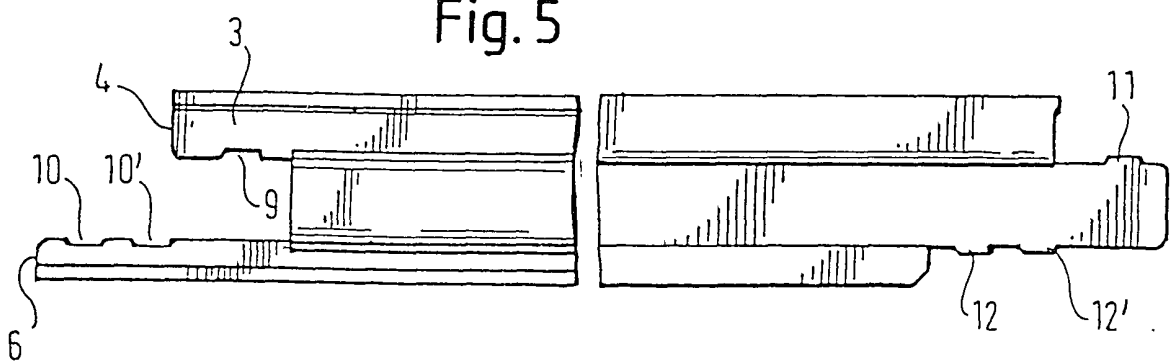

Fig. 6

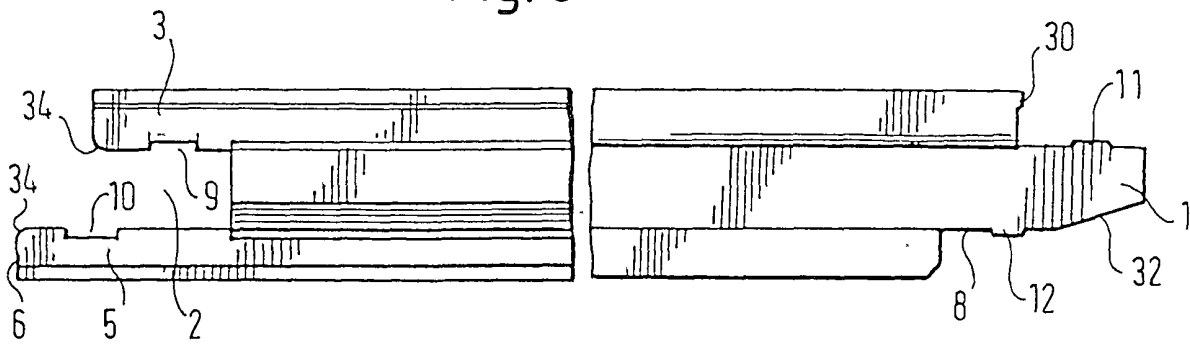

Fig. 7

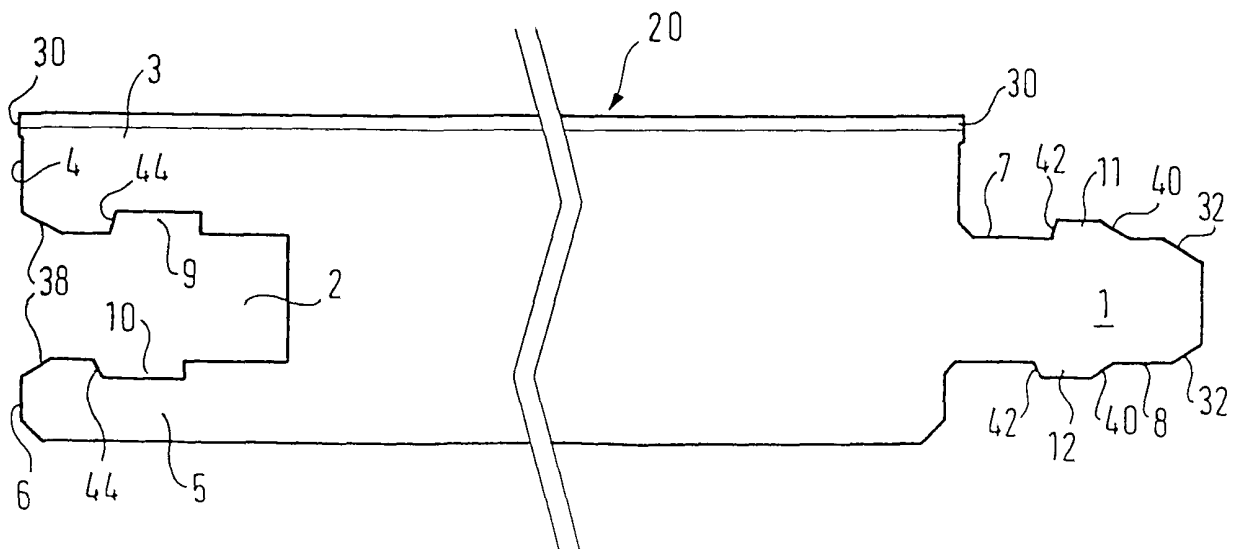

Fig. 8

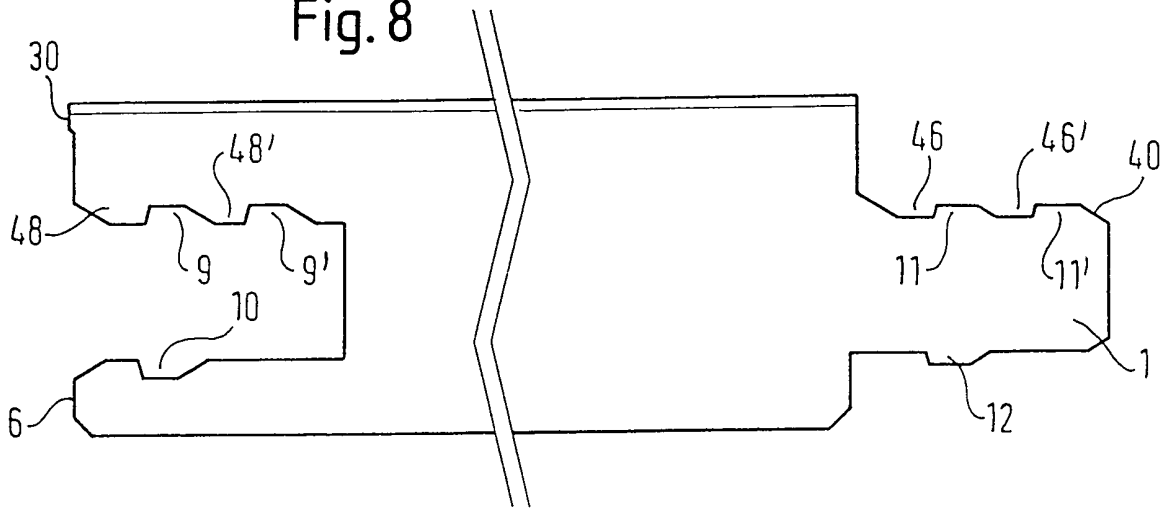

Fig. 9

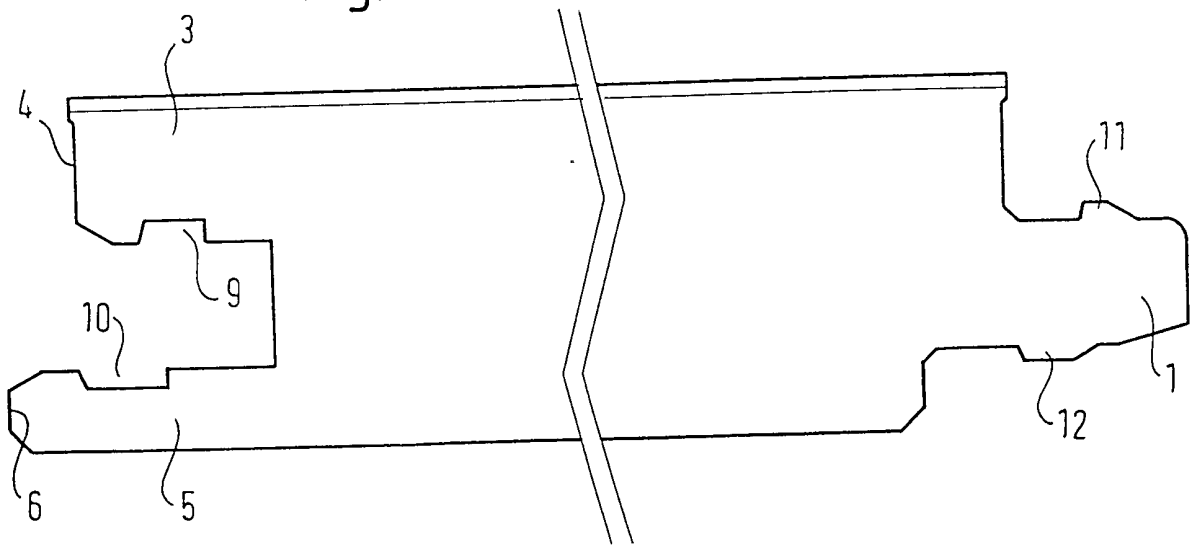
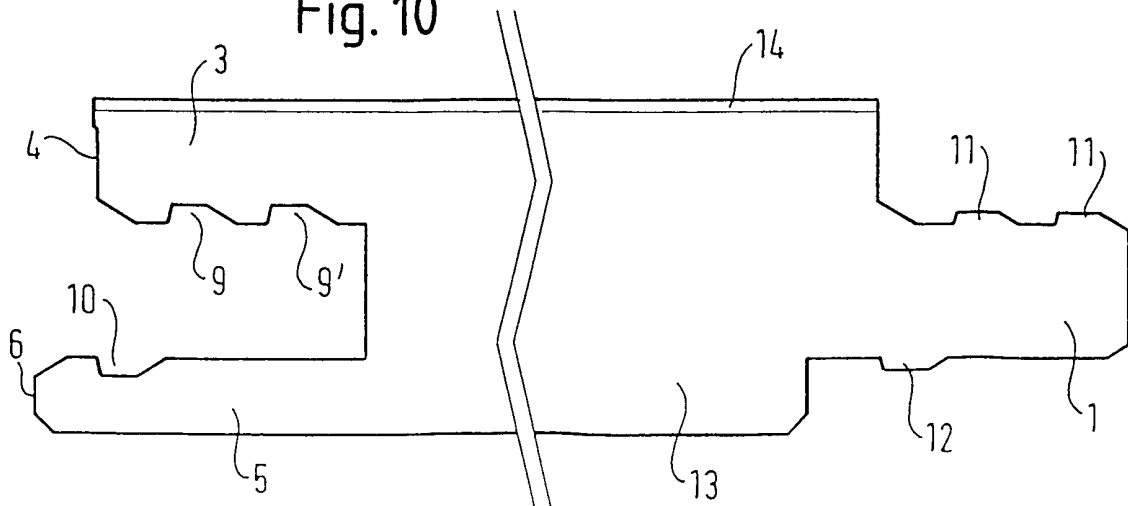

Fig. 10



INTERNATIONAL SEARCH REPORT

International application No.

PCT/SE 01/01159

A. CLASSIFICATION OF SUBJECT MATTER		
IPC7: E04F 15/04, E04F 13/08 According to International Patent Classification (IPC) or to both national classification and IPC		
B. FIELDS SEARCHED		
Minimum documentation searched (classification system followed by classification symbols)		
IPC7: E04F		
Documentation searched other than minimum documentation to the extent that such documents are included in the fields searched		
SE,DK,FI,NO classes as above		
Electronic data base consulted during the international search (name of data base and, where practicable, search terms used)		
C. DOCUMENTS CONSIDERED TO BE RELEVANT		
Category*	Citation of document, with indication, where appropriate, of the relevant passages	Relevant to claim No.
A	DE 3512204 A1 (HEINMANN, HERBERT), 16 October 1986 (16.10.86), figures 3,4, details 7,8,16,17 --	1-23
A	DE 4002547 A1 (THERMODACH DACHTECHNIK GMBH), 1 August 1991 (01.08.91), figure 3 --	1-23
A	DE 4242530 A1 (FRIEDL, WALTER ET AL), 23 June 1994 (23.06.94), figure 1, detail 18 --	1-23
A	WO 9627721 A1 (PERSTORP FLOORING AB), 12 Sept 1996 (12.09.96), figure 2, detail 9 --	1-23
<input checked="" type="checkbox"/> Further documents are listed in the continuation of Box C. <input checked="" type="checkbox"/> See patent family annex.		
* Special categories of cited documents:		
"A"	document defining the general state of the art which is not considered to be of particular relevance	"T"
"E"	earlier application or patent but published on or after the international filing date	later document published after the international filing date or priority date and not in conflict with the application but cited to understand the principle or theory underlying the invention
"L"	document which may throw doubts on priority claim(s) or which is cited to establish the publication date of another citation or other special reason (as specified)	"X"
"O"	document referring to an oral disclosure, use, exhibition or other means	document of particular relevance: the claimed invention cannot be considered novel or cannot be considered to involve an inventive step when the document is taken alone
"P"	document published prior to the international filing date but later than the priority date claimed	"Y"
		document of particular relevance: the claimed invention cannot be considered to involve an inventive step when the document is combined with one or more other such documents, such combination being obvious to a person skilled in the art
		"&"
		document member of the same patent family
Date of the actual completion of the international search		Date of mailing of the international search report
23 August 2001		14-09-2001
Name and mailing address of the ISA: Swedish Patent Office Box 5055, S-102 42 STOCKHOLM Facsimile No. +46 8 666 02 86		Authorized officer Örjan Nylund / JA A Telephone No. +46 8 782 25 00

INTERNATIONAL SEARCH REPORT

International application No.

PCT/SE 01/01159

C (Continuation). DOCUMENTS CONSIDERED TO BE RELEVANT

Category*	Citation of document, with indication, where appropriate, of the relevant passages	Relevant to claim No.
A	WO 9858142 A1 (M. KAINDL), 23 December 1998 (23.12.98), figure 2, details 7,8 --	1-23
A	WO 0028171 A1 (ROY, VALERIE), 18 May 2000 (18.05.00), figure 1, details 13,20 -- -----	1-23

INTERNATIONAL SEARCH REPORT

Information on patent family members

02/08/01

International application No.

PCT/SE 01/01159

Patent document cited in search report	Publication date	Patent family member(s)	Publication date
DE 3512204 A1	16/10/86	EP 0196672 A	08/10/86
DE 4002547 A1	01/08/91	IT 1240085 B IT 4786290 D	27/11/93 00/00/00
DE 4242530 A1	23/06/94	NONE	
WO 9627721 A1	12/09/96	AT 202826 T AU 4960096 A BR 9607272 A CA 2213757 A CN 1177390 A DE 29623914 U DE 69511554 D,T EP 0768929 A,B EP 0813641 A,B JP 10502303 T JP 11501377 T NO 974110 A RU 2136448 C SE 9500810 D US 5897272 A US 6101778 A	15/07/01 23/09/96 23/06/98 12/09/96 25/03/98 13/07/00 27/01/00 23/04/97 29/12/97 03/03/98 02/02/99 06/11/97 10/09/99 00/00/00 27/04/99 15/08/00
WO 9858142 A1	23/12/98	AT 106797 A AT 405560 B AU 8002698 A DE 29823749 U EP 1036244 A	15/01/99 27/09/99 04/01/99 30/12/99 20/09/00
WO 0028171 A1	18/05/00	AU 1165300 A FR 2785633 A,B US 6216409 B	29/05/00 12/05/00 17/04/01