

United States Patent

[11] 3,618,842

[72] Inventor **Graham W. Bryan**
Ridgefield, Conn.
 [21] Appl. No. **21,465**
 [22] Filed **Mar. 20, 1970**
 [45] Patented **Nov. 9, 1971**
 [73] Assignee **United States Surgical Corporation**
Baltimore, Md.

1,767,513 6/1930 Crosby 227/114
 2,930,041 3/1960 Massacrier 227/11
 2,930,043 3/1960 Bolling et al. 227/137 X

Primary Examiner—Granville Y. Custer, Jr.
Attorney—Fleit, Gipple & Jacobson

[54] **SURGICAL STAPLING CARTRIDGE WITH
 CYLINDRICAL DRIVING CAMS**
 24 Claims, 8 Drawing Figs.

[52] U.S. Cl. 227/138,
 227/19, 227/120
 [51] Int. Cl. B27F 7/24
 [50] Field of Search 227/19,
 114, 117, 120, 121, 135, 137, 138

References Cited

UNITED STATES PATENTS

1,125,411 1/1915 Szemerey 227/120 X

ABSTRACT: A sterilized disposable cartridge for a surgical instrument adapted to apply staples to the disunited skin or fascia of a patient in order to effect the joining of the tissue. A number of staples are housed in the staple-carrying cartridge and are supported and driven by means of a pair of threaded screws. The rear portion of each screw is provided with a cylindrical camming surface; and each screw is caused to rotate in response to the interaction between a driving member and its cylindrical camming surface. The associated surgical instrument is powered by a gas under pressure and employs a power unit having O-ring seals.

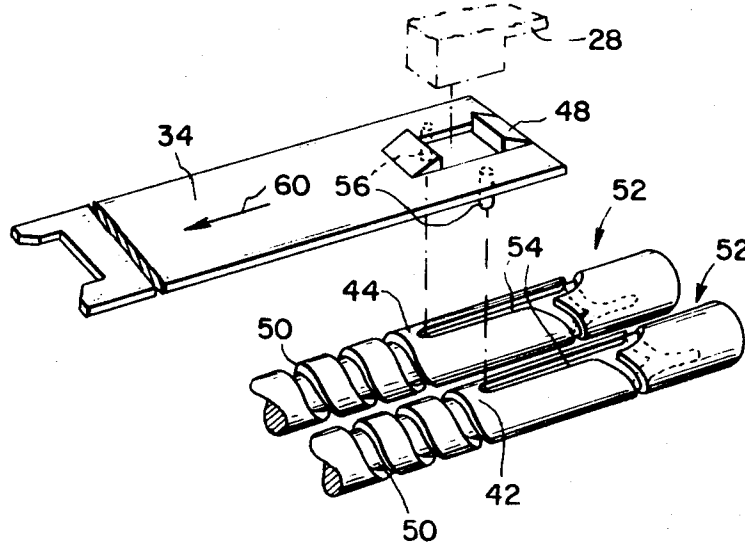

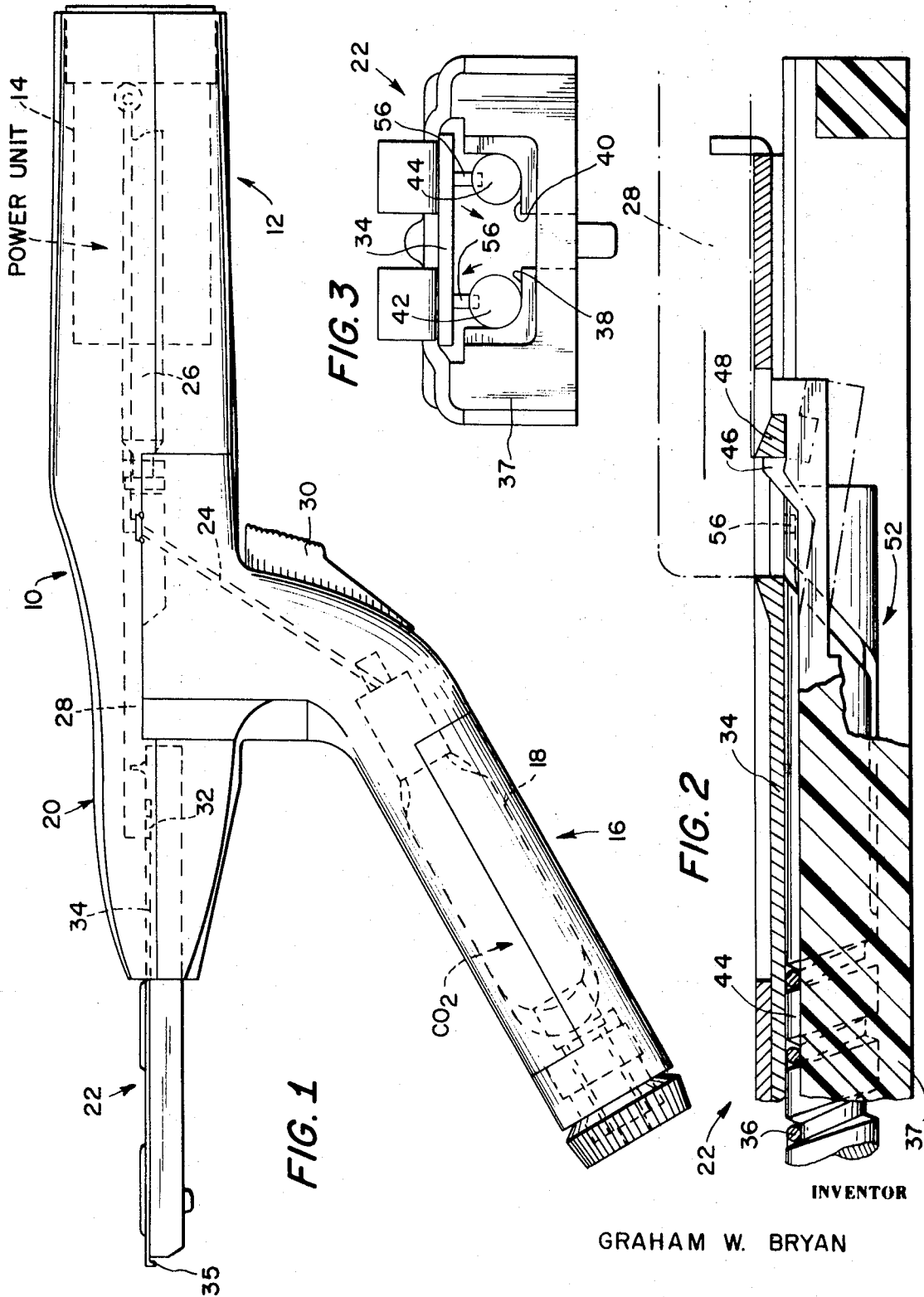

FIG. 1

FIG. 2

FIG. 3

INVENTOR

GRAHAM W. BRYAN

BY *Fleit, Gipple & Jacobson*
ATTORNEYS

FIG. 5

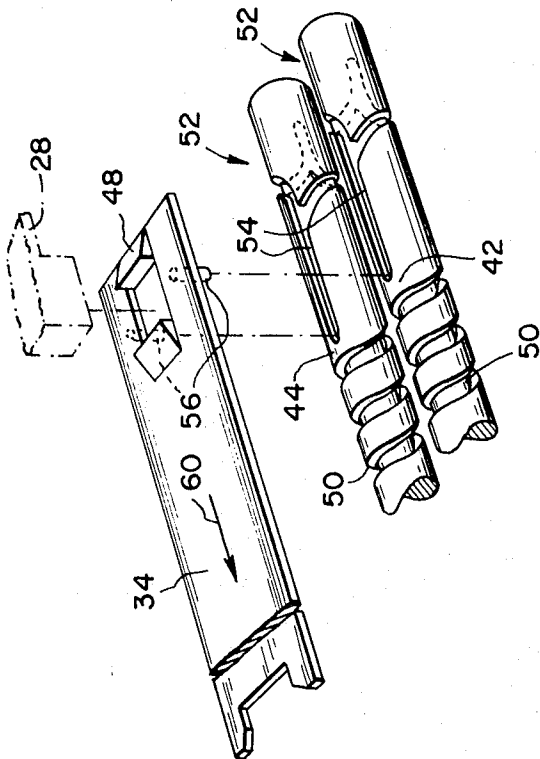
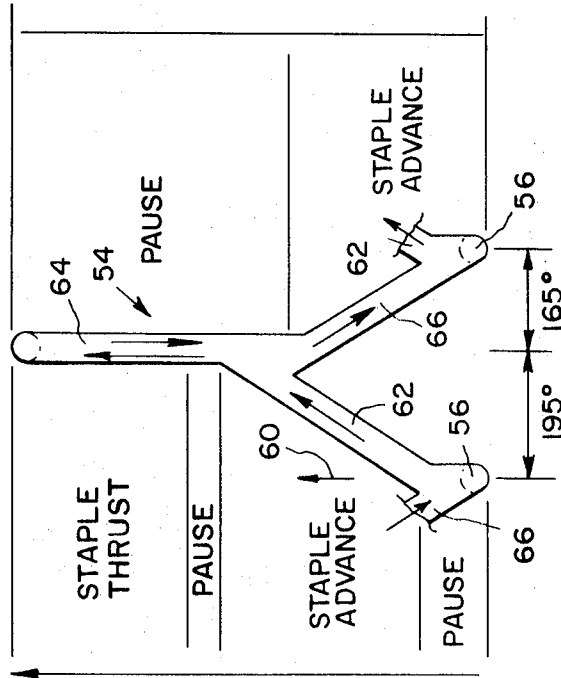
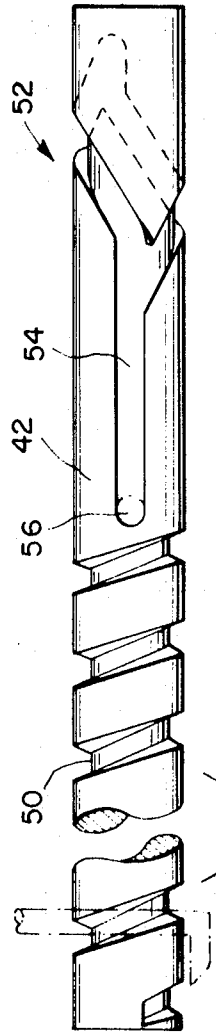

FIG. 4

FIG. 6



INVENTOR

GRAHAM W. BRYAN

BY

Flit, Gipple & Jacobson

ATTORNEYS

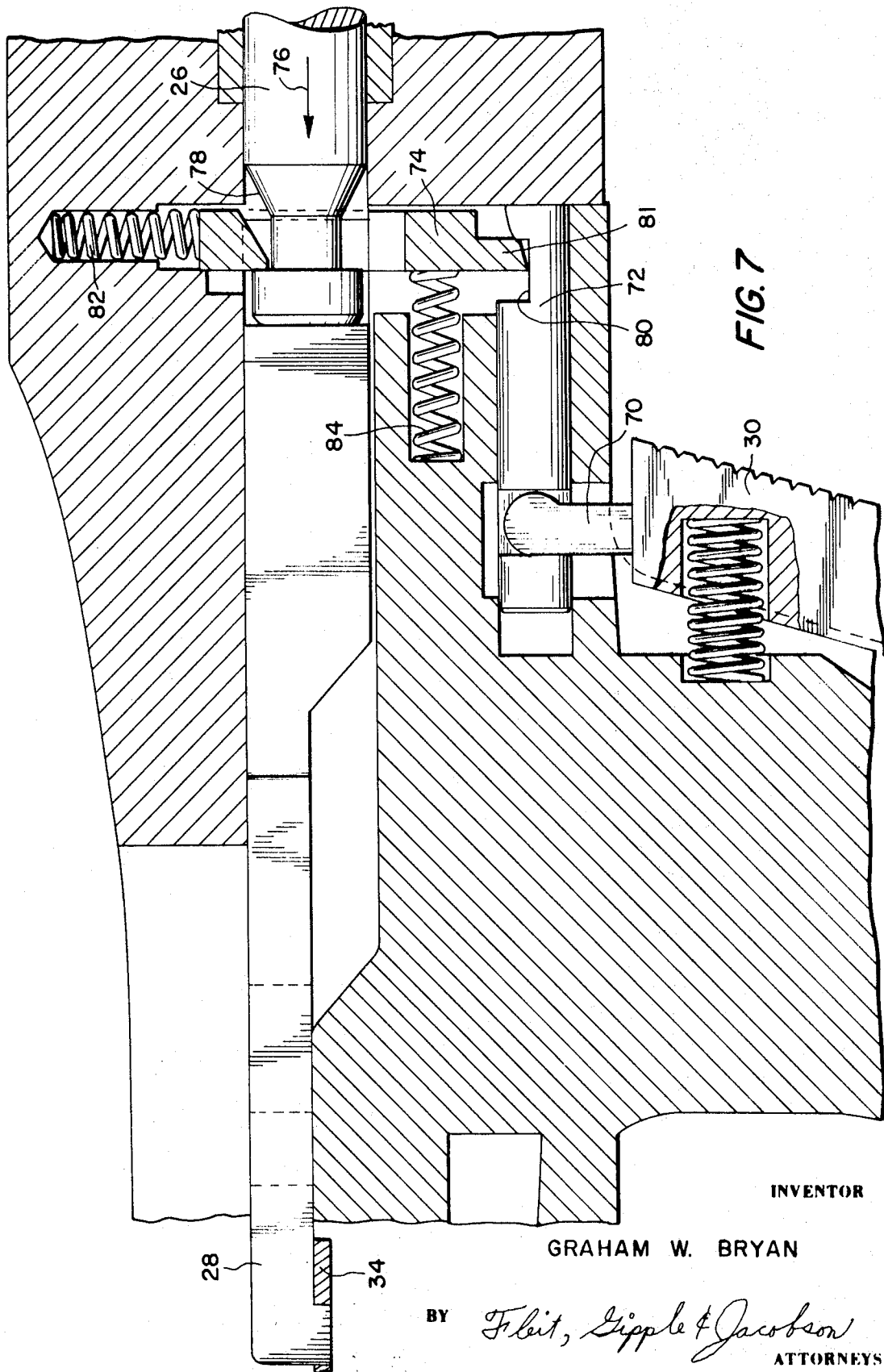

INVENTOR

GRAHAM W. BRYAN

BY

Fleit, Gipple & Jacobson

ATTORNEYS

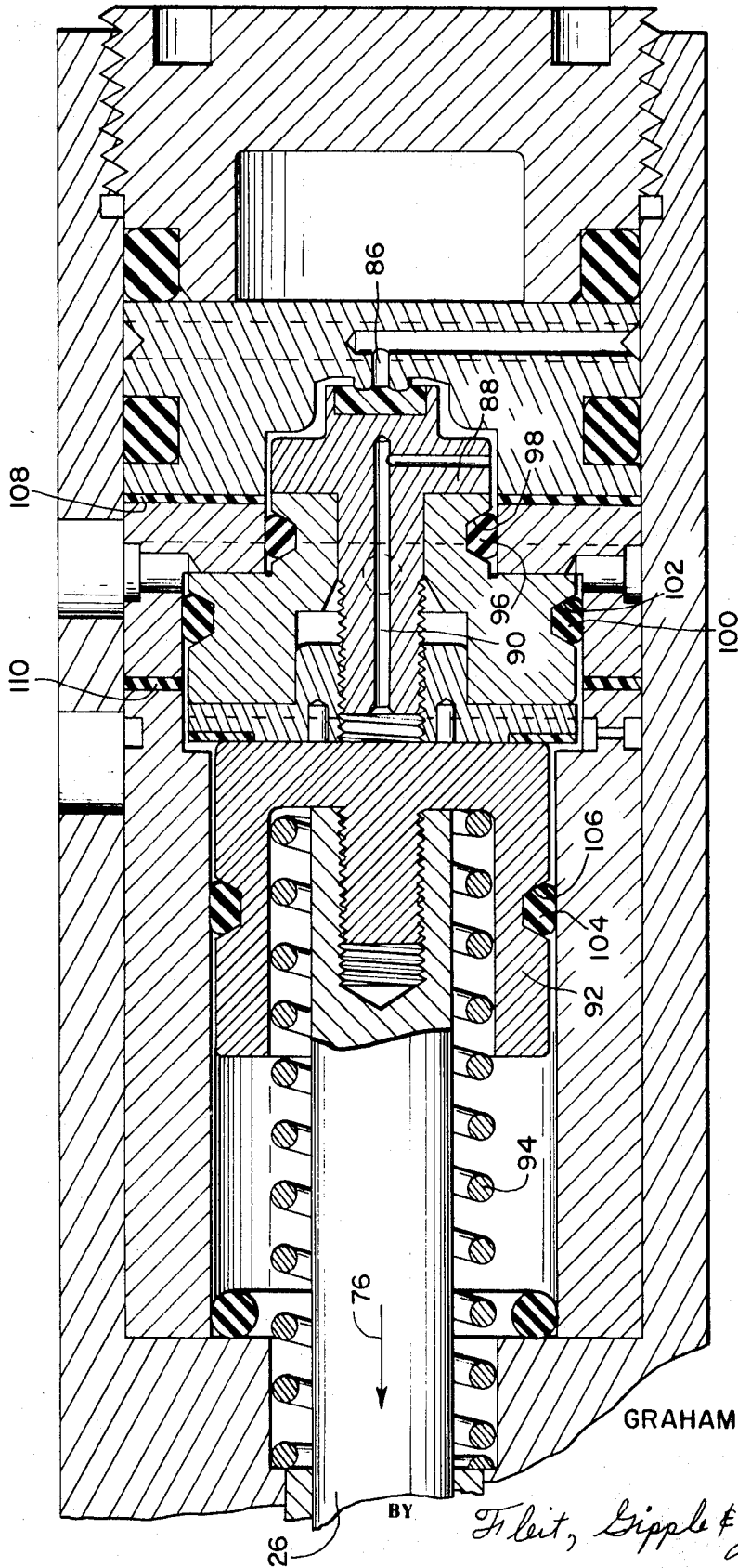

FIG. 8

INVENTOR

GRAHAM W. BRYAN

BY

Fleit, Gipple & Jacobson
ATTORNEYS

SURGICAL STAPLING CARTRIDGE WITH CYLINDRICAL DRIVING CAMS

BACKGROUND OF THE INVENTION

Surgical instruments for applying cartridge-housed sterilized staples to the disunited skin or fascia of a patient are known. See, for example, copending U.S. Pat. application Ser. No. 852,822 filed on Aug. 25, 1969 and entitled SKIN STAPLER, and copending U.S. Pat. application Ser. No. 14,614 filed on Feb. 26, 1970, and entitled SURGICAL STAPLER FOR SKIN AND FASCIA, each being assigned to the present assignee.

In these copending patent applications, gas powered medical instruments for assisting the surgeon in suturing the disunited skin or fascia of a patient are disclosed. Each of these instruments, however, relies upon a relatively complex gear arrangement for advancing the staples along the cartridge. Naturally, such a gear arrangement increases the basic cost of the instrument. Further, because of the large number of gears involved, the power requirements, both in the forward and return strokes of the instrument, are high. In addition, and again related to the large number of gears in these instruments, the prior art devices have many potential sources of trouble.

Each of the prior art instruments described above is adapted to be powered by a gas under pressure. These power units depend upon the definition of a number of pressure chambers and upon the operation of a number of sliding pistons. Accordingly, certain of the moving elements of the known power units are provided with sliding diaphragms to allow the associated pistons to move while still maintaining proper isolation between the individual pressure chambers. It has been found, however, that the sliding diaphragms are potential sources of trouble which may ultimately lead to the malfunctioning of the instrument.

The medical instruments described in the above-noted patent applications have been found to function quite well under surgical conditions. They are, however, somewhat complex in certain of their more critical areas. Because of this, the cost of manufacturing the instruments tends to be somewhat high. If, however, instruments could be simplified in certain of the more complex areas, then the price of manufacture could be lowered and, accordingly, the prices to the consumer could be lowered. It is toward the simplification of these types of surgical instruments that the present invention is directed.

SUMMARY OF THE INVENTION

The present invention relates to a surgical stapling instrument which is similar, in most respects, to the instruments described in the above-noted copending U.S. patent applications. However, the instrument of the present invention is less complex in the staple-driving and powering areas. Accordingly, the instrument of the present invention is less expensive to manufacture than the instruments noted above. Further, because of its reduced number of parts, the instrument of the present invention avoids certain potential areas of malfunctioning difficulties.

The present invention further relates to a new cartridge. The inventive cartridge, like those described in the copending patent applications, is provided with a pair of staple-advancing screws. However, these screws are made to turn, not through the action of a complex gearbox arrangement, but through the action of simple cylindrical camming surfaces formed as extensions of the staple-advancing screws. The associated pusher, adapted to eject the staples and to form the same around an anvil, is provided with a pair of cam-engaging pins. In this manner, the movement of the pusher causes a corresponding rotation in the staple-advancing screws, through the means of the cylindrical cams, thereby moving each of the staples forward.

The cylindrical cams are unique in their design. They are adapted, on each forward stroke of the pusher, to rotate their associated screws through angles of 165°. Then, on each

return stroke of the pusher, the cams cause their associated screws to rotate through an angle of 165°. Each rotation is in the same sense and, therefore, each complete cycle of the pusher, a forward stroke plus a rearward stroke, results in a 360° rotation of each screw. As explained in the above-noted copending patent applications, the pitch of each screw is chosen so that for a 360° rotation, the forwardmost staple is moved from its waiting position into a position ready for ejection. The staples are initially loaded into the cartridge with the staple-advancing screws turned through 165°. Therefore, when the associated instrument is fired, the forward stroke of the pusher turns the screws 195° advancing the forward staple into an ejection position. Each of the other staples is also advanced. Further, the cam surfaces are designed to ensure that the camming pins on the pusher always remain in the proper cam path.

As noted previously, the power units described in the copending patent applications use a number of sliding diaphragms. In the present invention, a gas powering unit is also employed. However, there are no sliding diaphragms used. Instead, a plurality of O-rings and rubber washers are used to define the necessary gas chambers and to prevent gas leakage from one chamber to the next. With the use of O-rings the sliding piston members are increased in their diameter so as to closely approximate the internal diameter of the chambers in which the pistons slide. Because of this, guiding elements are no longer required.

Accordingly, it is one object of the present invention to provide a surgical stapling instrument which is simple in design, economical and yet reliable.

It is a further object of the present invention to provide a staple-housing cartridge with integral staple-driving cams and adapted to mate with the simplified surgical instrument.

It is another object of the present invention to provide a staple-carrying cartridge provided with a pusher, a set of staple-advancing screws, and a set of cylindrical camming surfaces, the cartridge constructed in such a manner so that for each cycle of the pusher, one staple is ejected from the cartridge.

It is still a further object of the present invention to provide a surgical stapling instrument adapted to be powered by a gas under pressure and having a power unit which is simple in construction, relatively free from the dangers of internal damage, and totally devoid of sliding diaphragms.

These and other objects of the present invention, as well as many of the attendant advantages thereof, will become more readily apparent when reference is made to the following description taken in conjunction with the accompanying drawings.

BRIEF DESCRIPTION OF THE DRAWINGS

FIG. 1 is a side elevation of the surgical stapling instrument forming a part of the present invention, showing the novel staple-carrying cartridge mounted therein;

FIG. 2 is a cross section through the rear portion of the body of an inventive cartridge;

FIG. 3 is a rear view of the cartridge shown in FIG. 2;

FIG. 4 is an exploded perspective showing the relationship between the pusher, the camming pins and the cylindrical cams;

FIG. 5 is a developed view of the cylindrical cam forming a part of the present invention;

FIG. 6 is a top view of the inventive cam as it appears at the end of a stapling operation;

FIG. 7 is a sectional view showing the triggering mechanism of the invention surgical stapling instrument; and

FIG. 8 is a cross section through the power unit forming a part of the present invention.

DETAILED DESCRIPTION OF THE DRAWINGS

With reference first to FIG. 1, the instrument and cartridge forming parts of the present invention will be described. The inventive medical instrument is shown generally at 10 and

comprises, basically, a main body portion 12 serving to house a power unit 14, a handle portion 16 housing a tank of pressurized gas 18, and a nose portion 20 adapted for the insertion of a staple-carrying cartridge 22.

Pressurized gas is fed from the tank 18 through a gas port 24 and into the power unit 14. When the power unit is activated, a power shaft 26, integral with a drive shaft 28, is thrust toward the nose 20 of the instrument 10. The power unit is activated by depressing a trigger 30.

The forwardmost part of the drive shaft 28 has a projection 32 extending into the body of the cartridge 22 and adapted to positively engage the rearward end of a pusher element 34. Therefore, when the power unit 14 is activated, movement is imparted to the power shaft 26, the drive shaft 28 and the pusher element 34. And, as will be explained below, the movement of the pusher element 34 causes the staples in the cartridge 22 to advance and the forwardmost staple to be ejected and bent around an anvil 35.

With reference now to FIGS. 2, 3 and 4, the staple-carrying cartridge 22 will be described. The cartridge 22 comprises an elongated main body 37 having defined therein a pair of channels 38 and 40, respectively, extending through the length thereof. A pair of threaded screws 42 and 44 are positioned within the respective channels 38 and 40. As seen best in FIG. 2, the staples, designated 36, ride within the threads of the screws 42 and 44.

As was described in the latter of the two above-referenced copending applications, the cartridge of the present invention is provided with a pusher-engaging lock 46 adapted to engage the pusher 34 around its rearwardmost portion 48 to ensure that the pusher remains stationary during transit. When the drive shaft 28 engages the pusher 34, the lock 46 is moved out of engagement with the portion 48.

The cartridge of the present invention differs from those cartridges disclosed in the two above-referenced copending applications in that the inventive cartridge is provided with its own mechanism by which the movement of the pusher directly brings about the advancement of the staples. This mechanism can best be seen in FIGS. 4, 5 and 6.

In FIG. 4, the screws 42 and 44 are each shown to have threads 50 in which the staples are adapted to ride. A cam portion, shown generally at 52, is integral with the rear end of each of the respective screws and is defined by a series of slots 54 carved into the cylindrical body thereof. The pusher 34 is provided with a pair of camming pins 56, each pin 56 adapted to engage one of the slots 54. Therefore, when the pusher 34 is moved linearly through the action of the drive shaft 28, the screws 42 and 44 are made to rotate.

With reference now to FIGS. 5 and 6, the configuration of the cylindrical cams will be more fully explained. In FIG. 5, the camming groove 54 is shown "unwrapped" from its cylindrical form. One of the camming pins 56 is shown in its rest position in the grooves 54, the rest position being defined when the pusher is in its rearwardmost location. When the stapling instrument of the present invention is fired, the pusher moves so that its associated pins 56 move in the direction of the arrow 60. It should be remembered that the pusher, and hence the camming pins, move linearly. As a result, the screws 42 and 44, through the means of the cams 52, are caused to rotate. That is, as the pins 56 move in the direction of the arrow 60, the cylindrical cams 52 and their associated screw portions 42 and 44 are caused to rotate so that the staples are advanced in the threads 50. The precise camming sequence is as follows.

In FIG. 5, the legends on the left side of the cam groove 54 designate cam operation during the forward thrust of the pusher and its camming pins 56. The legends on the right side of the cam groove 52 describe the operation of the cam during the return stroke. On the forward stroke of the pusher and the pins 56, there is an initial "pause" experienced by the cams and their associated screws. That is, the pusher moves a small distance without rotating screws 42 and 44. After the small pause, the pin 56 contacts one wall of the leg 62 forming a part

of the groove 54. As the pin continues its motion in the direction of the arrow 60, the cam rotates and continues to do so until the pin 56 leaves the leg 62 and enters the leg 64. It can be seen that this leg runs parallel to the direction indicated by the arrow 60. Therefore, the pin 56 moves in the leg 64 without causing further rotation of the cam 52. During the return stroke of the pusher, the pin 56 moves back along the leg 64 until it contacts a wall of a crossover leg 66. When this occurs, the cam 52 again rotates, in the same sense as it was before rotated and continues to do so until the pin 56 finds itself in its rest position as illustrated in FIG. 5.

It will be noted from FIG. 5 that the legs of the groove 54 are associated with one another in such a manner that the pin 56 is ensured of engaging the desired leg both during its forward and its rearward voyage. This is accomplished by rotating the cam, each time the pin completes a voyage in a given leg, an amount bringing the pin out of alignment with the next leg and into alignment with next desired inlet leg. For example, when the pin 56 leaves leg 62 and enters leg 64, it finds itself out of alignment with exit leg 62 and in alignment with leg 66. In this manner, it is ensured that the staple drive is always positive and in the same direction.

With continuing reference to FIGS. 5 and 6, the operation of the cam 52 will be described in detail. First, it should be pointed out that each of the cam grooves 54 is cut into the cylindrical surface extending from its associated screw so that when the pin 56 is in its rest position (shown in FIG. 5), the staples have undergone a portion of their advancement in the cartridge 22, no staple then being made ready for ejection. In particular, when the pins 56 are in the rest positions, the staple-carrying screws have undergone 165° of rotation. Since the screws are adapted to properly advance a staple for each 360° rotation, there remains 195° through which the screws must rotate before the staple is ready to be ejected.

When the pins 56 engage and traverse the legs 62 of the respective slots 54, during the forward stroke of the pusher, the screws are rotated through this remaining 195°. Then, the pin leaves the leg 62 and enters the leg 64. At this time, one staple is in a position ready to be ejected. Shortly after the pin 56 enters the leg 64, after a brief nonrotational "pause," the forwardmost part of the pusher contacts the staple, ejects the staple from the cartridge, and bends the same around the anvil. After the full forward thrust of the pusher, the pusher begins its return stroke, bringing the pins 56 down through legs 64 and into the crossover leg 66. During the travel of the pins 56 in the respective legs 66, the screws are made to rotate through 165°. With the pin then resting in the position shown in FIG. 5, the instrument is again ready for a staple driving operation. FIG. 6 shows the position of the pins 56 at the forwardmost stroke of the pusher.

With reference now to FIGS. 7 and 8, the firing of the inventive surgical stapling instrument will be described. FIG. 7 shows the triggering mechanism and FIG. 8 shows the powering mechanism.

When the trigger 30 is depressed, a trigger-extension 70 brings about the movement of a first linkage 72 and a second linkage 74. When linkage 74 moves, in response to the activation of the trigger 30, the power shaft 26 is caused to move in the direction of arrow 76. At this occurrence, the power unit of FIG. 8 is activated and the power shaft 26, the drive shaft 28 and consequently the pusher 34 are driven to the left (of FIG. 7). In this manner, a staple is advanced, is ejected from the cartridge 22 and formed around the anvil 35.

As in the latest filed of the above-mentioned copending patent applications, the trigger mechanism shown in FIG. 7 has the safety feature that once the trigger 30 is depressed, the power unit will fire, but will fire only once for each trigger depression. This is brought about by the interaction between the linkages 72 and 74, an indentation 78 in the power shaft 26, a notch 80 in the linkage 72, an extension 81 in the linkage 74, a pair of biasing springs 82 and 84. The copending patent application fully describes the operation of this mechanism.

Now, with reference to FIG. 8, the improved power unit will be described. This power unit functions in a manner identical with the power units described in the referenced copending patent applications. Therefore, only the differences will be described. As mentioned previously, the known power units have depended, for their operation, upon the use of sliding diaphragms. As also mentioned, these diaphragms tend to be sources of potential malfunctions. The power unit shown in FIG. 8 is totally devoid of the sliding diaphragm, defining the independent pressure chambers by means of series of O-rings.

The power unit comprises, basically, a gas inlet port 86, a spool 88, a transfer port 90 extending from one side of the spool to the other, a piston 92 and a spring 94 serving to urge the piston 92 and thus the spool 88 against the gas inlet port 86. When the trigger 30 is activated, the power shaft 26 as explained previously, moves in the direction of arrow 76. When this occurs, the biasing action of the spring 94 is overcome and the piston 92 moves to the left. At the same time, the pressure developed by the gas exerts a force causing the spool 88 to move slightly to the left. At this occurrence, the gas passes through the transfer port 90 and exerts a large force on the piston 92 causing the piston, with its power shaft 26, to surge to the left.

In order for the device to operate in the manner described above, it is necessary to define three pressure chambers and to ensure that these chambers are pressure isolated from one another. The first chamber is that which is integral with the gas inlet port 96 and which is present when the spool 88 is moved to the left. This chamber is sealed by an O-ring 96 located in a ring-shaped notch 98 defined in the body of the spool 88. The second chamber is that which is present between the piston 92 and the spool 88 when the piston is thrust to the left in response to the operation of the pressurized gas. This chamber is sealed by means of a first O-ring 100 positioned within a second notch 102 in the spool 88 and another O-ring 104 lying within a notch 106 in the piston 92. The third chamber is defined between O-rings 96 and 100 and serves the function of a relief chamber ensuring free movement of the spool 88 without pressure buildup.

As shown in FIG. 8, two rubber washers 108 and 110 ensure that gas leakage between metallic parts is prevented. If desired, however, the metallic parts may be made integral and, as a consequence, the rubber washers could be eliminated.

It will be noted, when comparing the power unit shown in FIG. 8 with the power units described in the copending patent applications, that both the spool 88 and the piston 92 are of larger diameter than they were previously. This is made possible because of the replacement of the space-consuming slidable diaphragms by the efficient O-rings. Because of the resulting closer fit between the piston walls and the walls of the piston chambers, guiding elements are no longer required.

Above, a specific embodiment of the present invention has been described. It should be appreciated, however, that this embodiment is described for purposes of illustration only and that numerous alterations and modifications may be practiced by those skilled in the art without departing from the spirit and scope of the invention. Accordingly, it is the intent that the invention not be limited by the above but be limited only as defined in the appended claims.

I claim:

1. A staple-ejecting cartridge to be sterilized, packaged and mounted on a medical stapling instrument, the cartridge comprising: an elongated body adapted to house plurality of staples an anvil secured to one end of said elongated body; a pusher element in the plane of said anvil for reciprocating along the length of said elongated body, for ejecting said staples, singly, and for forming said staples around said anvil; means for positively guiding said staples along said body and toward said one end thereof; and cam means associated with said guiding means for advancing the staples along said body during the reciprocation of pusher means.

2. The cartridge defined in claim 1, wherein said cam means are acted upon by said pusher means.

3. The cartridge recited in claim 1, wherein said guiding means takes the form of at least one threaded screw, the threads of which are adapted to engage the crosspieces of said staples; and wherein said cam means takes the form of at least one cylindrical cam integral with said at least one threaded screw.

4. The cartridge defined in claim 3, wherein said cylindrical cam is defined by at least one set of cam grooves cut into a cylindrical cam surface.

5. The cartridge defined in claim 4, and further comprising at least one reciprocating cam pin adapted to engage each set of cam grooves for causing rotation of said cylindrical cam in response to the reciprocation of said cam pin.

6. The cartridge defined in claim 5, wherein said at least one cam pin is rigidly secured to said pusher.

7. The cartridge recited in claim 3, wherein said guiding means is mounted for rotation; wherein a predetermined rotation of said guiding means results in the advancement of each of said staples and the positioning of one of said staples in a staple-ejecting location; wherein a portion of said predetermined rotation is brought about each time said pusher means is driven toward said one end of said cartridge; and wherein the remaining portion of said predetermined rotation is brought about each time said pusher means is driven toward the opposite end of said cartridge.

8. The cartridge recited in claim 7, wherein said predetermined rotation is 360°.

9. The cartridge defined in claim 8, wherein said cam means rotate approximately one-half of the predetermined rotation during the forward stroke of the pusher and approximately one-half the desired rotation during the rearward stroke of the pusher.

10. The cartridge defined in claim 9, wherein the cylindrical cam rotates approximately 165° during the forward stroke of the pusher and rotates approximately 195° during the rearward stroke of the pusher.

11. The cartridge recited in claim 1, wherein said guiding means is mounted for rotation; wherein a predetermined rotation of said guiding means results in the advancement of each of said staples and the positioning of one of said staples in a staple-ejecting location; wherein a portion of said predetermined rotation is brought about each time said pusher means is driven toward said one end of said cartridge; and wherein the remaining portion of said predetermined rotation is brought about each time said pusher means is driven toward the opposite end of said cartridge.

12. The cartridge recited in claim 11, wherein said predetermined rotation is 360°.

13. The cartridge defined in claim 12, wherein the cylindrical cam rotates approximately 165° during the forward stroke of the pusher and rotates approximately 195° during the rearward stroke of the pusher.

14. The cartridge defined in claim 1, wherein said guiding means is in the form of first and second threaded screws, the threads of which are adapted to engage the crosspieces of said staples; wherein said cam means is in the form of first and second cylindrical cams integral, respectively, with said first and second threaded screws, each of said cylindrical cams comprising a set of cam grooves carved into the cylindrical body of said cam; and further comprising first and second cam pins integral with said pusher and adapted to engage respective sets of cam grooves; wherein said sets of cam grooves are carved into respective cylindrical cam surfaces in such a manner that for each forward stroke of the pusher, the cylindrical cams and their integral threaded screws are rotated through a first angle, and for each rearward stroke of the pusher, the cylindrical cams and their integral threaded screws are rotated, in the same sense, through a second angle, the rotation through said first and second angles advancing each of said staples and positioning one of said staples in a staple-ejecting location.

15. The cartridge defined in claim 14, wherein said first and said second angles are approximately equal.

16. The cartridge defined in claim 15, wherein said first angle is approximately 165° and wherein said second angle is approximately 195°.

17. The cartridge defined in claim 14, wherein a portion of each set of cam grooves is of such a configuration that the pusher ejects and forms a staple around said anvil without rotation of said cylindrical cams and their associated threaded screws.

18. The cartridge defined in claim 14, wherein said cylindrical cams and their associated threaded screws are rotated through 360° for each cycle of said pusher, each cycle comprising a forward and a reverse stroke.

19. The cartridge defined in claim 14, wherein the individual grooves of said sets of cam grooves are associated in such a manner that it is ensured that the cam pins always ride in the proper cam groove.

20. The cartridge defined in claim 18, wherein the individual grooves of said sets of cam grooves are associated so that each time the cam pins exit one cam groove and enter another, the cylindrical cams are rotated through an angle which aligns said cam pins with the entrances to the cam grooves into which it is desired that the cam pins enter.

21. The cartridge recited in claim 1, wherein the staples are

advanced by rotating said guiding means; wherein said cams are adapted for rotation and are integral with said guiding wherein said guiding means and said cams are rotated through a first angle for each forward drive of the pusher; wherein said guiding means and said cams are rotated through a second angle for each rearward drive of said pusher; and wherein means are provided for ensuring that said cams and said guiding means always rotate in the same direction.

22. The cartridge recited in claim 23, wherein each cam comprises a set of cam grooves; and further comprising cam pin means adapted to engage each set of cam grooves; wherein said sets of cam grooves are arranged in such a manner that each time said cam pin leaves its associated cam groove, the cams are rotated so that the cam pins are aligned with the entrances to the cam grooves in which entry is desired.

23. The cartridge recited in claim 1, and further comprising means for locking the pusher in its retracted rest position during all stages of transit.

24. The cartridge defined in claim 23, wherein said locking means is disengaged when the cartridge is mounted on the medical stapling instrument.

* * * * *

25

30

35

40

45

50

55

60

65

70

75