

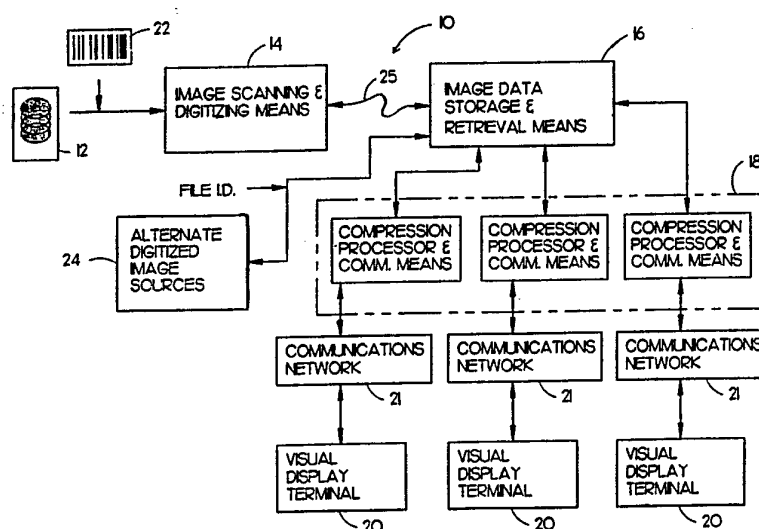

## INTERNATIONAL APPLICATION PUBLISHED UNDER THE PATENT COOPERATION TREATY (PCT)

<p>(51) International Patent Classification <sup>5</sup> : H04N 1/04, 1/21, 1/32 H04N 1/387, 1/393, 1/41 H01N 1/419</p>	A1	<p>(11) International Publication Number: <b>WO 94/03010</b>  (43) International Publication Date: 3 February 1994 (03.02.94)</p>
<p>(21) International Application Number: PCT/US93/06042 (22) International Filing Date: 24 June 1993 (24.06.93)  (30) Priority data: 07/915,298 20 July 1992 (20.07.92) US  (71) Applicant: AUTOMATED MEDICAL ACCESS CORPORATION [US/US]; 6701 Hanley Road, Tampa, FL 33634 (US). (72) Inventors: INGA, Jorge, Jaime ; 5804 Mariner Drive, Tampa, FL 33609 (US). SALIGA, Thomas, V. ; 4702 Baycrest Drive, Tampa, FL 33614 (US). (74) Agent: KIEWIT, David, A.; 2420 Seneca Court, Palm Harbor, FL 34683 (US).</p>		<p>(81) Designated States: CA, JP, European patent (AT, BE, CH, DE, DK, ES, FR, GB, GR, IE, IT, LU, MC, NL, PT, SE).  <b>Published</b> <i>With international search report. Before the expiration of the time limit for amending the claims and to be republished in the event of the receipt of amendments.</i></p>

(54) Title: AUTOMATED HIGH DEFINITION/RESOLUTION IMAGE STORAGE RETRIEVAL AND TRANSMISSION SYSTEM



## (57) Abstract

An automated high resolution/definition image storage retrieval, and transmission system provides fast, efficient access to medical diagnostic images, e.g. X-ray images, simultaneously to a plurality of requesting subscribers. This overcomes significant limitations of the prior art system that allowed only one user at a time to view a diagnostic image film that had to be physically transported to a different location for each viewing. The system digitizes images and stores the resultant data in a hierarchically compressed format on CD-ROMs (48). The data are subsequently downloaded, via the telephone lines, to a requesting subscriber in an optimal fashion. The data that are sent initially are used to create an initial, coarse, display of the image. Subsequent data are used to refine the resolution of the displayed image, up to a resolution limit set by the display terminal (20). This progressive enhancement process can be guided by the remote subscriber, who can select the most interesting areas of the image, to receive priority in the enhancement process.

**FOR THE PURPOSES OF INFORMATION ONLY**

Codes used to identify States party to the PCT on the front pages of pamphlets publishing international applications under the PCT.

AT	Austria	FR	France	MR	Mauritania
AU	Australia	GA	Gabon	MW	Malawi
BB	Barbados	GB	United Kingdom	NE	Niger
BE	Belgium	GN	Guinea	NL	Netherlands
BF	Burkina Faso	GR	Greece	NO	Norway
BG	Bulgaria	HU	Hungary	NZ	New Zealand
BJ	Benin	IE	Ireland	PL	Poland
BR	Brazil	IT	Italy	PT	Portugal
BY	Belarus	JP	Japan	RO	Romania
CA	Canada	KP	Democratic People's Republic of Korea	RU	Russian Federation
CF	Central African Republic	KR	Republic of Korea	SD	Sudan
CG	Congo	KZ	Kazakhstan	SE	Sweden
CH	Switzerland	LI	Liechtenstein	SI	Slovenia
CI	Côte d'Ivoire	LK	Sri Lanka	SK	Slovak Republic
CM	Cameroon	LU	Luxembourg	SN	Senegal
CN	China	LV	Latvia	TD	Chad
CS	Czechoslovakia	MC	Monaco	TG	Togo
CZ	Czech Republic	MG	Madagascar	UA	Ukraine
DE	Germany	ML	Mali	US	United States of America
DK	Denmark	MN	Mongolia	UZ	Uzbekistan
ES	Spain			VN	Viet Nam
FI	Finland				

**Title:** Automated High Definition/Resolution Image Storage  
Retrieval and Transmission System

### Technical Field

5

The invention provides an automated high definition/resolution diagnostic quality image storage, retrieval transmission, and display system for use with medical X-ray films and the like.

10

### Background Art

15

Storage and retrieval systems for medical image data such as X-ray films, CAT scans, angiograms, tomograms and MRI are commonly antiquated. For example, when image films are used in the operating room, the physician must display these photo films on a light box.

20

25

Moreover, due to the diffuse responsibilities of multiple attending physicians and treatment sites, image data for patients with complex conditions is often lost, or at best, difficult to find when needed. Hospitals maintain large "file rooms" to store bulky patient image data films. In a complex situation in which several folders are needed, a file's weight can build up to 7 kg. It has proven time consuming to obtain image data from file rooms due to administrative backlogs, to lack of specialized filing personnel and to misfiling.

30

Typically, the physician examines the patient in his office after radiographical studies have been made in a hospital or diagnostic facility. The relevant films and the information contained therein are often unavailable at the time of the examination. Thus, there is a need for remote access to image data for rapid patient assessment and therapy recommendation.

35

US 4,603,254 teaches a stimuable phosphor sheet that stores a radiation image and that is read out by scanning with stimulating rays. The light emitted from the sheet is detected

and converted into a digitizable electric signal used to reproduce the radiation image in diagnosis and storage.

5 US 4,764,870 describes a system for transferring medical diagnostic information from a diagnostic site to remote stations. An internal analog video signal from imaging diagnostic equipment is converted to a standard format for storage and transmissison to a CRT display for reproduction of diagnostic images.

10 US 5,005,126 shows a system for transferring medical diagnostic information from a diagnostic site to remote stations similar to that found in US 4,764,870.

15 US 5,019,975 teaches a medical image database that tags records with the time at which each medical image was recorded and with a rank of importance for each medical image and that logs the number of times a given record was retrieved. When the database is full, the oldest and least important records are deleted to allow for recording of new data.

20 US 4,611,247 describes a radiation image reproducing apparatus. In response to input on the nature of the radiation and of the imaged object, the unit determines the optimum gradation and spatial frequency processing conditions to use to reproduce a viewable image from a stored one.

25 US 4,750,137 discloses a method of optimizing signals exchanged between a host unit and an addressable-buffer peripheral device. The program optimizes an outgoing signal from the host unit by (1) creating an updated-state map representing the state of the peripheral device buffer expected to exist after processing by the peripheral device of the outgoing signal, (2) performing an exclusive-or (XOR) operation using the updated-state map and a present-state map representing the existing state of the buffer, and (3) constructing and transmitting a substitute outgoing signal which represents any changes to the buffer, and in which all premodified field flags are turned off.

US 4,858,129 teaches an X-ray CT apparatus in which dynamic tomographic images obtained by repeatedly photographing a region of interest are stored in an image memory. A processing device extracts data of pixels along a certain line common to all of the tomographic images and stores the pixel data in the image memory, in the order of photographing time of the tomographic images, thus forming a time sequence image. The processing device reduces a tomographic image and the time sequence image and rearranges the reduced images in one frame area of the image memory for simultaneous display on the display device.

US 5,021,770 discloses an image display system having a plurality of CRT display screens. A number of images of portions of a patient are selected from among a multitude of X-ray image taken by a plurality of shooting methods. In order that the segments to be inspected can be pointed to on the screen on which the image of the patient is displayed, a memory is provided to store codes corresponding to the specific image of the patient and to specify the respective regions of the image in such a manner that they correspond to the pixel positions of the image.

US 4,879,665 teaches a medical picture filing system composed of a picture data memory device, a picture data input-output device, a retrieving device for storing the picture data into the memory device and extracting it therefrom on the basis of retrieving data. When medical pictures are filed, retrieving data collected for each examination are utilized for reducing the amount of retrieving data, while when reproduced, retrieval is carried out for each one-time examination, thereby shortening the time required for retrieval.

#### Disclosure of Invention

The medical image data acquisition, processing, transmitting, display and storage system of the invention includes:

**PATIENT RADIOGRAPHY:** The patient's body is imaged and a film is exposed, as may be done in an X-ray room, MRI or CAT scan

lab.

FILM PREPARATION: The film(s) is developed to create a visible image with optical character reader (OCR) readable patient identification information superimposed thereon.

FILM INTERPRETATION: Commonly, a radiologist drafts a opinion letter for the film(s). This document preferably includes an OCR readable patient identification label or standard marking area.

IMAGE SCANNING & DIGITIZATION SUBSYSTEM: A scanner subsystem digitizes each patient image film and/or document on a high resolution scanner. Digitized data are transmitted by a local high speed data link to a separate or remote master storage unit. Patient identification information is read from a standard format label on each film by OCR and is stored with the digitized image data. Enhanced scanner resolution and gray scale requirements are provided. Further, to reduce data rate requirements, data compaction or compression is accomplished within the scanner subsystem.

To back-up possible data link down time or scanner down time, the scanner subsystem may include a CD-ROM data storage drive so that image data may continue to be digitized. The CD-ROM disk may then be manually delivered to the file room unit.

In an optional embodiment, the digitized data of one or two images may be written to a compact semi-conductor memory card "RAM Cards". This form of data storage may be used to send selected images for special purposes such as when the image data is needed in another city for a second opinion.

At this point in the image data flow, there is a split in which the original film data is stored as a "master" in a file room and the image disk is made available for active "on-line" use in an image storage and retrieval subsystem.

FILM FILING: The patient image films may be placed in the industry standard 14 by 17 inch (35.6 x 43.2 cm) brown paper folders and placed on conventional filing shelves. Older films can be tagged and stored off-site to reduce the bulk of films in many hospital file rooms. The system would make this practical since the original films would seldom need to be accessed.

In the preferred embodiment of the system, the patient may have his entire image data collected and written to one or more of the storage CD-ROM disks for archiving at the hospital.

IMAGE STORAGE AND RETRIEVAL SUBSYSTEM: This subsystem is a remotely controllable, automatically accessible image data subsystem to store and automatically retrieve, on-demand, the compressed digital information contained on the CD-ROM disks.

The image storage and retrieval subsystem has a high-speed data link connection to the scanning and digitizing subsystem and has a write drive (recording mechanism) which is dedicated to receiving the data from the scanning and digitizing subsystem. This CD-ROM write drive can operate without interrupting remote access operations.

Remote access may be made to the image storage and retrieval subsystem by a variety of telecommunication links. Access will be granted only if a valid user code has been presented. By means of several read-only CD disk drives and electronic buffering, virtually simultaneous access can be granted to several or more users.

TELECOMMUNICATION SUBSYSTEM: As explained more fully hereinafter, the medical image disk will contain relatively huge quantities of data making it impractical to send over conventional data communication links without very efficient data compression technology. While there are a variety of data compression techniques available, none are well tailored to this application. Thus, novel compression means are in a remote telecommunication access subsystem.

A novel medical facsimile technology in the preferred embodiment works interactively with a remote requester to send only what is needed at acceptable resolutions. The presented image is progressively updated as the communications connection is maintained until the resolution limit of the user display is reached, after which time other images are either sent or further enhanced.

The specific technical means for accomplishing this uses the following novel technologies: a) guided image selection and transmission (GIST), b) progressive image enhancement (PIE), c) display compatible resolution (DCR); d) hexagonal pattern classification compression (HexPac); and e) run length coding (RLC). RLC is well known to those skilled in the arts.

It appears practical to send immediately useful patient data in less than one minute over a phone line (9600 baud) whereas it takes many hours by conventional coding and transmission means. In practice, these technologies may be implemented for the most part with available computer modules although several special signal processor boards are needed.

**REMOTE DISPLAY TERMINAL:** The quality of the image available to the user is limited or determined by the receiving presentation terminal or monitor. Two specific presentation terminal types are envisioned in the preferred embodiment of the system, a modified personal computer terminal for use in a physician's office, hospital nurses' station and the like, and a large screen presentation terminal with remote controlled interaction primarily for operating room use.

Both terminals have means to show the available patient directory of images, and means to select an image, and to enhance and zoom on selected areas. Image enhancement has heretofore been impractical for film based images and thus much subtle but important pathological information has been largely lost. This is especially true of X-ray data. The ability to enhance subtle contrasted tissues areas is considered to be an important feature



and benefit of the system.

An optional high-resolution printer (120 dots per cm or better) permits the physician to print out selected images. This will be especially valuable when the physician expands and enhances selected critical image areas since a cost effective printer would otherwise not have adequate gray scale or pixel resolution to give diagnostically useful output.

Each terminal consists of a standard high performance personal computer with one or more data source interfaces such as RAM card, CD-ROM disk or data modem, a decompression graphics interface circuit and graphics display. The large screen presentation terminal has a large screen display for easy viewing for a surgeon who may be three or more meters distant. The large screen presentation terminal also has an optional remote control so that an attending technician or nurse can scroll, enhance and zoom images at the surgeon's request.

A keynote of each terminal design is a very simple user interface based upon a limited selection menu and obviously pointed-to graphical icons. Other known features, such as touch-screen selection of commands and split image display screen overlays are also to be used in the system.

#### Brief Description of Drawings

Fig. 1 is a functional block diagram of the entire system of the present invention.

Fig. 2 is a functional block diagram of the image scanning and digitizing means.

Fig. 3 is a functional block diagram of the image data storage and retrieval means.

Fig. 4 is a perspective view of the image data storage and retrieval means.

Fig. 5 is a functional block diagram of the telecommunication means.

Fig. 6 is a functional block diagram of the remote display terminal means.

Fig. 7 depicts the hexagonal pattern of the hexagonal compression method.

Fig. 8 depicts an actual hexagonal pattern from an X-ray film.

Fig. 9 depicts the selected predetermined hexagonal pattern most closely corresponding to the actual hexagonal pattern shown in Fig. 8.

Fig. 10 graphically represents the predetermined rotational orientations for the predetermined hexagonal patterns.

Fig. 11 graphically depicts a selected gray level slope of the selected predetermined hexagonal pattern of Fig. 9.

Fig. 12 depicts a single pixel from the predetermined hexagonal pattern.

Fig. 13 depicts a hexagonal pattern reconstructed by a remote display terminal means corresponding to the actual hexagonal pattern shown in Fig. 8.

Figs. 14-A through 14-H depict the predetermined set of orthogonal gray level patterns.

Similar reference characters refer to similar parts throughout the several views of the drawings.

35

#### Best Mode for Carrying out the Invention

As shown in Fig. 1, the present invention relates to an

automated high definition/resolution image storage, retrieval and transmission system, generally indicated as 10, for use with medical X-ray film 12 or other documents to provide simultaneous automated access to a common data base by a plurality of remote subscribers upon request from the remote subscribers.

The automated high definition/resolution image storage, retrieval and transmission system 10 comprises an image scanning and digitizing means 14 to transform the visual image from the medical X-ray film 12 or other documents into digital data, an image data storage and retrieval means 16 to store and selectively transfer digital data upon request, a telecommunication means 18 to selectively receive digital data from the image data storage and retrieval means 16 for transmission to one of a plurality of remote visual display terminals, each indicated as 20, upon request from the respective remote visual display terminal 20 through a corresponding communications network 21 such as a telephone line, satellite link, cable network or local area network such as Ethernet or an ISDN service for conversion to a visual image for display at the remote requesting site.

To improve automation and tracking, a machine readable indicium or label 22 containing key patient information may be used in association with the medical X-ray film 12. As shown, the machine readable indicium or label 22 is affixed to the medical X-ray film 12 prior to scanning by the image scanning and digitizing means 14 to provide file access and identification. Furthermore, digital data from alternate digitized image sources, collectively indicated as 24, and file identification may be fed to the image data storage and retrieval means 16 for storage and retrieval.

Fig. 2 is a functional block diagram of the image scanning and digitizing means 14 capable of converting the visual image from the medical X-ray film 12 to digitized image data for transmission to the image data storage and retrieval means 16

over a bi-directional high speed data link 25. Specifically, the image scanning and digitizing means 14 comprises a film loading and scanning section and a data compression and transmission section generally indicated as 26 and 27 respectively and a display and control section generally indicated as 28. The film loading and scanning section 26 comprises a film input loader 30, alignment and sizing chamber 32, optical character reader 34 and film scanner/digitizer 36 capable of at least two hundred dots per centimeter resolution 36; while the data compression and transmission section 27 comprises a data buffer memory 38, low-loss data compression means 40, local data modem 42 and transmission connector 44 to operatively couple the image scanning and digitizing means 14 to the image data storage and retrieval means 16. The low-loss data compressor 40 is also operatively coupled to a compact disk data storage drive 46 capable of writing or storing compressed digitized patient image data on a compact disk 48. The display and control section 28 comprises a keyboard/control console 50, display terminal 52 and control computer 54 which is operatively coupled to the other components of the image scanning and digitizing means 14 through a plurality of conductors each indicated as 55. A film collector tray 56 may be disposed adjacent the film scanner/digitizer 36 to receive the medical X-ray film 12 therefrom following processing.

To reduce the approximately 238 Megapixels required to digitize a 35.6 x 43.2 cm, medical X-ray film 12 with two hundred seventy five or more dots or pixels per centimeter with a two byte level to a manageable size without significant information loss, a linear gray level prediction, modified run-length code generating logic circuitry is embodied within the low-loss data compression means 40 to dynamically compress digitized data before storage or recording. The image data is compressed with acceptable diagnostic resolution loss. The low-loss data compression means 40 measures the "local" slope of the pixel gray level and continues to compare that estimated gray level for up to an entire scan line until a pixel region is reached which differs from the linear estimate by more than

a predetermined amount. The data actually sent for that region consists of the slope of the line, actual level at the origin of the slope line and the number of pixels comprising that region. The circuitry will discard linear gray level slope differences of the original film which can be reliably  
5 determined to be noise or image "artifacts". A sudden one pixel dramatic change in gray level (if at four hundred dots per centimeter) could be rejected as dust or film noise, for example. The compressed data is a trade-off between  
10 complexity, speed and minimum data loss to reduce the total data quantity stored by a factor of approximately three. Thus, about 80 Megapixels of data may still have to be stored per 35.6 x 43.2 cm film image.

15 In the preferred embodiment, the bi-directional high speed communications link 25 transmits the low-loss compressed digitized data from the developing lab room to the hospital file room where the image data storage and retrieval means 16  
20 will transfer and store the patient and image data in a new patient file on a compact disk 48.

Two way communications between the image scanning and digitizing means 14 and the image data storage and retrieval means 16 minimizes data loss by insuring that a compact disk 48  
25 is available. Moreover, the compact disk data storage drive 46 with re-writable ROM technology can record data even if communications with the image data storage and retrieval means 16 is disrupted. Thus the image scanning and digitizing means 14 can automatically start writing data to the compact disk  
30 data storage drive 46 as soon as a fault is sensed in the image data storage and retrieval means 16. The display and control section 28 informs the operator of the system status.

The film lab technician may stack one or more medical  
35 X-ray films 12 on the input loader 30 as shown in Fig. 2. A "read" button is depressed on the keyboard/control console 50 and each film 12 is fed automatically, digitized and transmitted to the image data storage and retrieval means 16

located in the file room. After each film 12 is read, it is deposited in the film collector tray 56. System status, a log of number-of-films read, and so forth are shown on the display terminal 52.

5

Initially, the image scanning and digitizing means 14 positions the film 12 in the alignment and sizing chamber 32 on a precision carrying platen for subsequent optical scanning. This platen contains optical sensors to sense the exact film size so only the useful image area is digitized. Once the film 10 12 is secured onto the movable platen, the film 12 is passed through the optical character reader 34 and then to the film scanner/digitizer 36.

15

The patient data and image identification is first recorded onto the remote CD-ROM file directory in the image data storage and retrieval means 16 from the OCR "pass" and then the compressed scanned image data is sequentially written to a compact disk 48 by a CD write drive for storage with the 20 CD library storage of the image data storage and retrieval means 16, as described more fully hereinafter, as the film 12 slowly passes through the film scanner/digitizer 36. Specifically, the film scanner/digitizer 36 converts the image to a digital representation of preferably at least two hundred 25 seventy five dot per centimeter resolution. These digital data are temporarily stored in the data buffer memory 38 where patient data from the optical character reader 34 and corresponding digitized image data from the film scanner/digitizer 36 are formatted for subsequent compression and 30 transmission to the image data storage and retrieval means 16. Stored data are accessed by and compressed by the data compression means 40, as previously described, and transmitted through the local data modem 42 and transmission connector 44 to the image data storage and retrieval means 16 or to a 35 compact disk data storage drive 46. The display and control section 28 permits X-ray lab staff to monitor system status, report quantity of documents and films processed, and allow scheduling of local image data recording on compact disks 48.

Figs. 3 and 4 show the image data storage and retrieval means 16 to receive and store the low-loss compressed digitized patient information and image data from the image scanning and digitizing means 14 and to selectively transmit the stored low-loss compressed digitized patient information and image data to one or more of the remote visual display terminal(s) 20 through corresponding telecommunication means 18 and corresponding communications network(s) 21 upon request from one or more of the remote display terminal(s) 20.

The image data and retrieval means 16 is essentially a central data storage library for medical subscribers to remotely access and visually display patient data and information.

As described hereinafter, the image data storage and retrieval means 16 is robotically automated to minimize hospital staff requirements. At any given time, it is estimated that a typical hospital may have several hundred active patients with requirements for physician access to corresponding image files. An active patient may require one to three compact disks 48. Thus, the image data storage and retrieval means 16 should have sufficient means to store and retrieve at least 500 compact disks 48.

Further, to minimize personnel requirements, the image data storage and retrieval means 16 has a semi-automatic log-in mechanism for updating the compact disk inventory and an automatic mechanism for retrieving and reading the compact disks 48 remotely via communication link interfaces similar to juke box playback mechanisms. Except for the occasional loading of new empty compact disks 48 and removal of inactive compact disks 48, the operation of the image data storage and retrieval means 16 is fully automatic, permitting authorized access at any time.

As described more fully hereinafter, several playback drives with electronic buffering are incorporated so that

essentially simultaneous access can be provided to several remote requesting users. An optional duplicating CD write drive and RAM-Card drive permits additional copies to be made locally upon demand for either back-up or other use. The image data storage and retrieval means 16 has an operator's console/desk arrangement for file maintenance and duplicating control by the hospital file room clerk. Control software is a simple menu selection design so that relatively unskilled personnel can maintain the central data storage library or image data bank.

As shown in the functional block diagram of Fig. 3, the image data storage and retrieval means 16 comprises a local data modem 58 operatively coupled between the image scanning and digitizing means 14 through the transmission connectors 44 and bi-directional high speed communication link 25, and a selector or multiplexer 60. A format convertor 62 is operatively coupled between the alternate digitized image source(s) 24 such as CAT 64, MRI 66 and/or video 68 and control computer 70 which is, in turn, coupled to a control console 72 including a visual display and input means such as a keyboard. The local data modem 58 is also coupled to the hard disk (H/D) of the control computer 70 through a conductor 71. The other components of the image data storage and retrieval means 16 are coupled to the control computer 70 through a plurality of conductors, each indicated as 73. A CD write drive 74 is operatively coupled between the multiplexer or selector 60 and an auto disk storage/retrieve mechanism 76 which is, in turn, operatively coupled to a CD library storage 78, a manual load/purge box 80 and a plurality of data retrieval and transmission channels, each indicated as 81.

Each data retrieval and transmission channel 81 comprises a CD reader drive 82 operatively coupled through a corresponding data interface 84 to a corresponding transmission connector 86. In addition, one of the CD reader drives 82 is operatively coupled through a selector switch 88 to an optional CD write/RAM card drive 90 configured to manually receive a



compact disk 48 or RAM card.

Internal to the environmentally controlled cabinet 200 are a plurality of playback mechanisms (field expandable to six) which are automatically controlled by the accessing physicians via the coupled communications system. As shown in Fig. 4, the CD library storage 78 comprises at least one cabinet 200 to operatively house eight hundred compact disks 48 arranged on four shelves, each indicated as 202, and the auto disk storage/retrieval mechanism 76, which comprises a CD coupler 204 to engage and grasp a selected compact disk 48 and move horizontally on a support member 206 that moves vertically on a pair of end support members, each indicated as 208. An access door 210 permits movement of compact disks 48 to and from the cabinet 200. In normal operation, "old" patient data is removed by writing collected image data to a single compact disk 48 through the CD write/RAM card drive 90, thus freeing internally disposed compact disks 48 for new data. The CD write/RAM card drive 90 may also be used to collect a patient's image data on a single compact disk 48 for use in the operating room's display terminal. This obviates the need for a high speed internal hospital local area network.

The computer associated with the CD robotic arm and drive mechanism performs ordinary library maintenance functions such as retrieval of outdated files, access statistics, entry of access validation codes, and so forth. This computer subsystem also handles data communication interface functions.

The internal computer maintains a file log of which compact disks 48 are empty and where each patient's image data is stored by disk number and track on a disk location. When the image scanning and digitizing means 14 requests to down-load data, the auto disk storage/retrieval mechanism 70, of the image data storage and retrieval means 16 retrieves the "current" compact disk 48 which is being written with data (if not already loaded), then loads the compact disk 48 into the CD write drive 74, and signals to the image scanning and

digitizing means 14 to transmit. Image data is then recorded with a typical record time of four minutes for a full-size, high density image.

5           Once the robotic arm has delivered the compact disk 48 to the CD write drive 74, the robotic arm is free to access and place other compact disks 48 onto CD reader drive 82 as commanded by its communications interface. The robotic arm can find and place a disk 48 into the appropriate CD reader 82 in  
10 approximately ten seconds. Thus, there is minimal waiting time for disk access unless all CD readers drives 82 are in use.

As shown in Fig. 3, data are received through the input transmission connector 44 to the CD write drive 74 through the  
15 selector switch 60. Alternately, other image data from other sources such as CAT scanners 64 or MRI medical equipment 66 may be fed through the format convertor 62 for storage on a compact disk 48. If the other image sources are written to CD write drive 74, file identification data must be supplied to the  
20 format convertor 62 from the control computer 70.

The image file data received from the image scanning and digitizing means 14 is directly written to free space on a compact disk 48 in the CD write drive 74. No other data  
25 compression or special formatting is required, as the image scanning and digitizing means 14 has performed these functions. As new image data are received from the image scanning and digitizing means 14 or another image source 24, the image data are sequentially appended to the last file on the compact disk  
30 48 currently being written to. Thus, no attempt is made to organize a single patient's image files onto a single compact disk 48. However, each file received is logged into the control computer 70 through the conductor 71. Therefore the control computer 70 always knows what disk location in the CD  
35 library storage 78 contains any specified file. Once a compact disk 48 is filled with image data, the auto disk storage/retrieve mechanism 76 removes the compact disk 48 from the CD write drive 74 and stores the compact disk 48 in an

empty location in the CD library storage 78.

The plurality of data retrieval and transmission channels 81 service the data requests from subscribers. As previously indicated, a single data retrieval and transmission channel 81 includes the select switch 88 to direct image file data to the optional CD write/RAM card drive 90. By this means, all image data for an individual patient may be collected on one or more selected compact disks 48 for archiving or other use. However, normally, the control computer 70 will automatically remove old image data by removing the compact disk 48 from the CD library storage 78 and placing the compact disk 48 in the manual load/purge box 80. The removal age and exceptions information are selected by the system operator from the control console 72.

The control console 72 is also used to enter and maintain subscriber access identification codes in an "authorization file". This updated user authorization file data are sent through a transmission connector 92 to the telecommunications means 18 internal computer memory accessed by the control computer 70 as needed to accept or reject subscriber data link access requests. The user authorization file normally residing in the telecommunications means 18, may be remotely updated.

The number of data retrieval and transmission channels 81 depends on intended subscriber demand. The image data storage and retrieval means 16 is modular and may be upgraded as demand increases. Each data interface 84 operates cooperatively with the telecommunications means 18 to send only as much information as the telecommunications means 18 can compress and transmit to a remote visual display terminal 20 of a requesting subscriber in a given time interval. Thus, the interface is an asynchronous block-buffered type.

Since the entire system 10 is designed to provide easy and quick access to a patient's medical images, it is vital that these images be transmitted to a variety of locations in a

timely and cost effective manner and further data compression is imperative. The telephone network is still the most commonly available network but has a severe data rate limitation of about 1200 bytes per second (9600 baud). While  
5 other high speed telecommunication channels such as time-shared cable, satellite link may eventually become commonly available, for the immediately foreseeable future, the "phone" network must be used if system 10 is to be practical today.

10 As noted earlier, a typical medical image may be stored as 119 megabytes of data. At 1200 bytes per second, it could take 27 hours to completely transmit the already compressed medical image data. This is obviously unacceptable. To  
15 overcome this obstacle, the telecommunications means 18 as shown in Fig. 5 utilizes five distinct data handling technologies to achieve useful data image transmission in less than one minute:

(1) Guided Image Selection and Transmission or (GIST)  
20 depends upon interactive use by the physician to identify what portions of an image are needed for enhancement or better resolution. Thus, the data actually transmitted to the subscriber visual display terminal 20 is guided by the  
25 subscriber observing the image. In particular, once the user has an image displayed on his or her visual display terminal 20, the user may outline a specific region of interest such as a lesion or tumorous growth for more detailed study. The operator may select this region using a mouse or light pen or similar well-known computer display terminal peripheral device.  
30 Having selected this region, the visual display terminal 20 will display the more detailed pixel data present in this region. The telecommunications means 18 will continue to send further precision data until the natural resolution limits of the display are reached or all available data are sent and  
35 received. This process of expanding an image region is known as "zooming" in computer-aided design systems. The novel feature here is that the image is further refined in resolution when zoomed. The means for doing this and knowing when to stop

further pixel transmission is defined by the PIE and DCR technology described hereinafter,

5 (2) Progressive Image Enhancement or PIE utilizes the transmission time from the instant a first "crude" image is presented to the subscriber to the present time of observation to progressively enhance the quality of the presented image. The longer the user observes a selected image, the better the image becomes in the sense of pixel resolution and quantity of gray levels. In the preferred embodiment, hexagonal pixel groups are first transmitted using the HexPac pattern compression technology described hereinafter. Once a full terminal screen display has been made composed of these hexagonal patterns, then the telecommunications means 18 transmits more precise pixel detail. First, all pixels located on the periphery of each hexagonal group are updated with their exact gray level values and thereafter, all inner pixels are similarly updated. If the display terminal's resolution is less than four hundred dot per centimeter of the source image data, then pixel groups are send, such as a square of four pixels, which match the display resolution and "zoom" expansion selected. This display matching technique is further defined hereinafter as DCR.

25 (3) Display Compatible Resolution or DCR transmits information about the user's terminal 20 back to the telecommunications means 18. Only data with a resolution compatible with that terminal will be sent. Any excess data-link connect time can be used to send other image data which is likely to be requested or has been prespecified to be sent.

35 (4) An image pattern compression method comprising a Hexagonal Pattern Classification or HexPac exploits the two dimensional nature of images. The data received by telecommunications means 18 is first uncompressed and placed into a multi-scanline digital buffer. This image data are then divided up into hexagonal cells and matched against predefined patterns. Many fewer bits of data can be used to represent

these predefined patterns, thus substantially compressing the image data for phone-line transmission. The pixels of these hexagonal patterns may easily be "refined" by the PIE technology described earlier. If the DCR subsystem determines that the user terminal has a pixel area of, say, 1500 by 1000 dots, then the HexPac technology recreates a new super pixel which is the average gray level of all actual pixels within that super pixel area. This immediately reduces the quantity of pixels to be sent (to only 1500 by 1000 pixels). Without further data compression, this quantity of data would require about twenty-six minutes of transmission time at 9600 baud.

(5) Run length coding or RLC permits data to be compressed by specifying how many pixels have the same gray level in a sequence or "run length" of scanning. The image data sent by a CD reader drive 82 to telecommunications means 18 is compressed with run-length coding but is nearly loss-less in the duplication of the original film data. To substantially reduce the quantity of data needed to send an acceptable medical image to a remote user terminal 20 over the data-rate limited phone-line modem, a "lossy" compression is used. Since the PIE and DCR techniques described earlier will eventually provide any degree of diagnostic image integrity desired, it is believed acceptable to initially transmit a "lossy" image provided it gives adequate resolution for the user to begin the analysis and guided image selection. Many fewer bits can describe this "run" of similar gray levels, thus compressing the amount of data sent. This technique is well known and often used in facsimile transmission. A one dimensional RLC is incorporated in the preferred embodiment but since HexPac elements are being coded, it can be more accurately considered a quasi-two dimensional RLC compression.

Fig. 5 is a functional block diagram of the telecommunications means 18 including a control computer 94 operatively coupled to the image data storage and retrieval means 16 through a transmission connector 96. The various components of the telecommunications means 18 including a

status panel 98 with a plurality of system indicators, each indicated as 99, and a plurality of data compression channels, each generally indicated as 100, coupled to control computer 94 by a plurality of conductors, each indicated as 101.

5

Each data compression channel 100 comprises a transmission connector 86, a communications data interface 102; a first compression processor or means 104, including logic means to generate the GIST and DCR data compressions and corresponding first data memory 106; a second compression processor or means 108, including logic means to generate the PIE and HEXPAC data compressions and corresponding second data memory 110; and a third compression processor or means 12, including logic means to generate the RLC data compression and corresponding third data memory 114; a corresponding modem 116; and a transmission connector 118.

20

25

30

35

The control computer 94 coordinates or controls data flow to and from the plurality of data compression channels 100 through the transmission connectors 86 and 118, respectively. Validated subscriber image data requests are transmitted to the image data storage and retrieval means 16 which searches the image library file 78 for availability of the requested compact disk 48. If available, the image data storage and retrieval means 16 loads the appropriate disk 48 from CD library storage 78 into a CD reader drive 82 and informs telecommunications means 18 through the transmission connector 96 to the control computer 94 that a specific data interface 84 has data available to be transmitted through the corresponding transmission connectors 86. Once a subscriber transaction has been turned over to a specific data retrieval and transmission channel 81, the data compression channel 100 receives the data therefrom unless commanded to stop by a feedback control line. The data interface 102 is used to inform the CD reader drive 82 as to what portion of the image is requested by the first compression means 104. Generally, the complete image is first requested. Thus the CD reader drive 82 is requested to read the image data from the start.

The data are temporarily stored in the first data memory 106. Here the pixel data are first expanded from the RLC mode into uncompressed pixel data. This is only done on a relatively few scan lines - about one quarter of a centimeter height of original image data. This uncompressed data are then remapped by the first compression means 104 into "larger" pixels whose average intensity is the average of all combined pixels compatible with the display resolution receiving remote visual display terminal 20. This "super pixel" data are then fed to the second data memory 110. The super pixel data in memory 110 is then processed by the second compression means 108.

Initially, the lowest resolution image will be transmitted to rapidly form a useful remote image on the requesting remote visual display terminal 20 through a communications network 21. This will be done by combining super pixels in the second data memory 110 into hexagonal patterns which approximate the group of super pixels. These HexPac data packets are then sent to the third data memory 114, where the HexPac data packets are further compressed by the third compression means 112. These packets of run-length coded HexPac data packets are then transmitted through the corresponding modem 116 and transmission connector 118 over the selected communications network 21. The modem 116 includes state of the art error control techniques such as block retransmission when a remote error has been detected. Thus, data transmission is essentially error-free as needed for compressed data handling.

The control computer 94 includes circuitry to monitor the activity of each data channel. The identification of each subscriber is logged, along with the total connect time for billing purposes. Thus the control computer 94 generally coordinates the plurality of communication lines and their connections to the particular data retrieval and transmission channel 81 within the image data storage and retrieval means 16 as well as granting access and performing connection accounting tasks. The status panel 98, connected to the control computer



94, aids in system debug and indicates operation of the data compression channels 100. The status panel 98 would not normally be used by operators, but by service technicians.

5           The control computer 94 also has a permanent memory, such as a hard disk, to record subscriber usage data and internally sensed hardware problems. These data may be downloaded on any of the transmission connectors 118 when a correct authorization code has been received. Thus, the servicing company can  
10 acquire subscriber usage information remotely for billing and system diagnostic purposes.

          The preferred embodiment of the telecommunications means  
18 uses modular communication channel hardware. Thus, the  
15 module may be customized to function with any type of communication channel such as satellite links, cable networks or a local area network such as Ethernet or ISDN services.

          It is important to note that all communications is  
20 bidirectional so that if, say, a remote visual display terminal 20 should become temporarily "overloaded" with image data due to decompression processing delays, or due to a detected data error, then the remote visual display terminal 20 may request that data transmission be stopped or a block of data be  
25 repeated until it is received correctly.

          Fig. 7 graphically shows a hexagonal group of the hexagonal compression method comprising a group of square image pixels partitioned into a hexagonal group. The pixels are  
30 numbered for convenience of reference from the inside to the outside in a clock-wise manner. Each hexagonal group or packet comprises twenty four super pixels, but other numbers are possible. It is assumed that each pixel is gray level encoded as two bytes of data. Thus, the hexagonal group requires forty  
35 eight bytes of data to fully represent the twenty four super pixels comprising the image pattern at the user terminal 20.

          Fig. 8 shows a typical pattern as may occur in a region of

an X-ray film 12. The method predefines a group of likely patterns, one of which is represented as a "best" match, as in Fig. 9, with the actual pattern in Fig. 8. As shown in Figs. 14A through 14H, there are eight possible predetermined  
5 representative gray level patterns represented by three bits. These patterns are specifically selected to be essentially uncorrelated with each other when rotated relative to each other. As shown in Fig. 10, these patterns may be rotated through eight equal angles (another three bits of data) to best  
10 match the actual pattern. Rotation angle "1" is shown in Fig. 10 as the best match for the given example. Thus far, six bits have been used to approximate the actual pattern of Fig. 8. As shown in Figs. 14A through 14H, each fictitious pattern includes a dark and light regions and origin. Although Fig. 11  
15 discloses a straight gray level slope corresponding to the pattern shown in Fig. 14A, the gray level slope will vary with the fictitious pattern. For example, the gray level slope of the fictitious pattern shown in Fig. 14D would closely approximate a V shape.

20

Fig. 11 shows how the gray level slope may be discretely selected to best match the slope of the actual pattern. Two bits are used to approximate this slope.

25

Fig. 12 shows that one particular pixel, such as the darkest pixel, has been selected to be fairly precisely gray level represented by means of eight bits (256 gray levels).

30

The total bits required to approximate the actual pattern is sixteen, or two bytes. Fig. 13 shows how this fictitious or reconstructed pattern may be reproduced at the user terminal 20 when decoded.

35

In this example, only two bytes were required to represent "adequately" an original forty eight bytes of image data. Thus, a 24:1 compression ratio has been achieved. Further, run-length encoding (RLC) may be used on these HexPac groups to further reduce redundant spans of white and black. It is

estimated that the combined compression ratio of HexPac and RLC on the super-pixel image is about 36:1 for this particular set of parameters. This combined compression technology reduces data transmission time (at 9600 baud ) to approximately forty  
5 three seconds for an initial useful medical image.

For medical images, further enhancements through the PIE compression should favor the elimination of artificial lining between hexagonal patterns first. As the user continues to  
10 view the same image the PIE compression will progressively improve the gray level integrity by updating all number 24 pixels to 8 bits of gray level resolution and updating all number 23 pixels to eight bits of gray level and so forth for all remaining pixels in descending order. This process takes  
15 about ten minutes at 9600 baud to update all peripheral hexagonal pixels and about twenty minutes for all pixels.

If the user continues to observe or request further image resolution, the telecommunication means 20 causes each pixel gray level to be updated by one additional bit in descending order again until the full 16 bits of gray level is received and stored at the terminal 20 for each super pixel. Each doubling of gray level resolution takes between 1 and 2.6  
20 minutes at 9600 baud, depending on the run length statistics of the gray levels.  
25

Fig. 6 is a functional block diagram of a remote visual display terminal 20 to be operatively coupled to one of the data compression channels 100 of the telecommunication means 18  
30 by a communications network 21 and a transmission connector 118. The visual display terminal 20 comprises a data communications modem 120 operatively coupled to a control computer 122 and RLC decompression means 124. The RLC decompression means 124 is, in turn, operatively coupled to a  
35 memory 126, a PIE bypass 128 and a pattern select and modifier 130 which is operatively coupled to a HexPac pattern ROM 132 and the control computer 122. A memory 134 is operatively coupled between the PIE bypass 128 and pattern selector and

modifier 130 and a display drive 136 which is operatively coupled to an image display 138. In addition, an image enhancing processor means 139 includes circuitry to generate edge contrast enhancement, gray level contrast enhancement by means of gray level region expansion or differential gray level tracking and gray level enhancement or other known image enhancement methods. The control computer 122 is operatively coupled to an Interface 140 to a first control or selector means 142 and a second control or selector means, including a radio receiver 144, and signal command decoder 146 for use with portable keyboard transmitter 148. In addition, an optional CD read/write drive 150 may be provided for use with a compact disk 48.

The modem 120 has built-in compatible error correction technology to communicate with corresponding transmitting~ data compression channel 100 . After the user has selected the image data storage and retrieval means 16 and validated authority by swiping a magnetic identification card 152 through a magnetic card reader 154, or otherwise entering an assigned security code, the operator may select a patient and one or more image files is presented to him on the display screen 138. Selection is accomplished by a touch-screen overlay on the first control or selector means 142 or by the keyboard transmitter 148 of the second control or selector means.

Once one or more images have been selected by the user, the modem 120 writes image data to the temporary memory 126 which is actively accessed by the RLC decompression means 124. These decompressed data describe the HexPac patterns or packets as stripes of the image running, for example, sequentially from left to right. These Hexpac pattern specifications, typically two data bytes or sixteen bits are then routed to a pattern selection processor 130 which accesses the predefined patterns from Read-Only Memory device 132. Each pattern is then rotated and gray-level modified by processor 130 according to the HexPac 16 bit pattern specification received from the RLC decompression means 124. Each modified pattern is then written

to a graphics display memory circuit 134. As the graphics display memory circuit 134 develops the pattern data, the display driver 136 and image display 138 show the image on the screen as it is received. In this manner, the entire "first pass" medical image is painted on the image display 138 screen.

If the user makes no further intervention, once the image is fully displayed on this "first pass" then the progressive image enhancement technology requests pixel enhancement data. This enhancement data bypasses pattern selector and modifier 130, and is routed through the PIE bypass 128. In the PIE bypass 128, the enhanced pixel information is directed to the correct graphic memory locations in the graphics display means circuit 134'. Thus, the display driver 136 and image display 138 are continually resolution enhanced.

If the image is fully enhanced to the limits set by the DCR in the control computer 122, the image storage and retrieval means 16 is directed by the control computer 122 to begin sending new image data on the next selected image and begin storing this image data in a second graphics display memory circuit 134". This second data memory 134" can hold one or more images and may be selected immediately by the user when he is finished inspecting an earlier image. The user may further direct, by touch screen command 142, that these be stored in the computer's hard disk or archived by the optional CD read/write drive 150.

The user may, at any time, select a portion of the displayed image for further expansion by enabling or selecting the Guided Image Selection and Transmission (GIST) circuitry in the control computer 122 or image enhancement through the image enhancing processor means 139. This may be accomplished either by touch screen control means 142 or the second remote control means 144/146/148. This remote keyboard and transmitter unit 144/146/148 duplicates the on-display simulated push-buttons of the touch screen control means 142. Coded command signals sent

by 148 are received by radio receiver 144 and decoded by 146. These commands are then accepted by control computer 122 as though they were normal keyboard commands.

5           The user may terminate a session with the image data storage and retrieval means 16 at any time by selection of stop and escape command. While a printer is not shown in this description, it can be an optional addition to terminal 20.

10           In summary, the image data storage and retrieval means 16 selects the first image and writes that data to a temporary memory buffer in the telecommunication means 18. Information about the subscriber's terminal is uploaded to the telecommunications means 18 so that the Display Compatible  
15 Resolution (DCR) logic circuitry knows when to stop sending added data for the requested first image. A special interactive compression computer then compresses this first image data using the HexPac circuitry and sends that data over the data link modem to the subscriber terminal 20. Error  
20 detection and correction methods will generally be used in this communications link protocol.

          Once a first "crude" image is sent to the subscriber visual display terminal 20, then the Progressive Image  
25 Enhancement (PIE) circuitry begins to send additional data to further refine the resolution of each hexagonal pixel region. If no further guidance is given by the subscriber, the PIE will continue to refine the picture's resolution until its natural limit is sent for the terminal 20. Thereafter, the PIE will  
30 begin sending image data from the second specified film and loading it into yet another memory buffer. Thus, the data link connection is always transmitting useful data even though the subscriber may only be analyzing one image for some time.

35           However, should the user desire to zoom in on a particular region of an image, he or she may define that region desired on the terminal 20 by the Guided Image Selection and Transmission (GIST) to expand the visual display accordingly. The DCR will

recognize the requirement for additional resolution and command the PIE to begin transmitting additional pixel information until such time as the DCR informs it that the resolution Limit has been reached.

5

The following image enhancement means are present in the instant invention: edge contrast enhancement, gray level contrast enhancement by means of gray level region expansion or differential gray level tracking and gray level enhancement, and may be accomplished by the image enhancing processor means 10 139 in the visual display terminals 20. The human eye cannot reliably discern gray level differences less than approximately 2%. Yet, significant tissue density information causes X-ray gray level differences in this range and below. The 15 enhancement technologies above will cause these tissue density differences to be magnified thus revealing hitherto unseen image data.

### Industrial Applicability

20

The invention uses recent advances in computer data bases, digitization and compression of image data, image enhancement algorithms, and cost effective computer technology to provide improved storage and retrieval of vital patient image data.

25

The system includes the following major features:

1) means to more compactly store and more efficiently retrieve image data and automatically identify the data by 30 patient name, image type, date and the like;

2) means for physicians to quickly and remotely access particular patient image data at a medical facility even if archived at several different locations;

35

3) means to prevent loss of vital image data due to ordinary human handling and misplacement errors;

4) means to quickly and affordably access image data from the physician's office;

5) means to enhance the medical images by both contrast enhancement and zooming for improved diagnostics and/or surgical guidance; and

6) means to quickly and conveniently access image data and display on a large screen in the operating room with any desired enhancement or expansion.

Although the present invention has been described with respect to several preferred embodiments, many modifications and alterations can be made without departing from the invention. Accordingly, it is intended that all such modifications and alterations be considered as within the spirit and scope of the invention as defined in the attached claims.

What is desired to be secured by Letters Patent is:



## CLAIMS

1 1. An automated high definition/resolution image storage,  
2 retrieval and transmission system for use with medical images  
3 to provide simultaneous automated access to a remote image data  
4 base by a plurality of remote subscribers upon request over a  
5 communications network, said image storage, retrieval and  
6 transmission system comprising

7 image digitizing means adapted to form a first digitized  
8 representation of said image,

9 first data compression means to generate from said first  
10 digitized representation a low-loss second digitized  
11 representation of said image,

12 image data storage and retrieval means including

13 means to receive and store said second digitized  
14 representation and to selectively provide said second  
15 digitized representation to

16 data channel compression means adapted to compress  
17 said second digitized representation to form a third  
18 digitized representation and

19 means to selectively provide said third digitized  
20 representation upon request from a remote site, to

21 telecommunication means including means to selectively  
22 transmit said requested third digitized representation to  
23 a requesting remote visual display terminal, said remote  
24 terminal including means to convert said third  
25 representation to a visual image for display.

1 2. A system of Claim 1 wherein said image digitizing means  
2 comprises a film loading and scanning section having means to  
3 read and scan a said image from a film.

1 3. A system of Claim 2 wherein said film loading and scanning  
2 section further comprises means to form a said first digitized  
3 representation capable of yielding a said visually displayable  
4 image with a resolution of at least 200 dots per centimeter.

1 4. A system of Claim 2 wherein said first data compression  
2 means further comprises a data buffer memory to receive said  
3 first digitized representation from said film loading and  
4 scanning section and a data modem to transmit said second  
5 digitized representation to said image data storage and  
6 retrieval means.

1 5. A system of Claim 2 wherein said image digitizing means  
2 further comprises an optical character reader.

1 6. A system of Claim 5 wherein individual patient information  
2 corresponding to said film is fed to said film loading and  
3 scanning section to be read by said optical character reader  
4 for compression and transmission with a corresponding second  
5 digital representation to said image data storage and retrieval  
6 means.

1 7. A system of Claim 1 wherein said remote visual display  
2 terminal further includes image enhancement means to enhance a  
3 displayed image.

1 8. A system of Claim 7 wherein said image enhancement means  
2 includes logic means to enhance an edge contrast of a displayed  
3 image.

1 9. A system of Claim 7 wherein said image enhancement means  
2 includes logic means to enhance gray level contrast by means of  
3 gray level region expansion.

1 10. A system of Claim 7 wherein said image enhancement means  
2 includes logic means for differential gray level tracking and  
3 gray level enhancement.

1 11. A system of Claim 1 wherein said first data compression  
2 means includes logic means to generate a run-length compressed  
3 digitized image data signal as said second representation.

1 12. A system of Claim 1 wherein said first data compression  
2 means is operatively coupled to an external data storage drive  
3 to store said second representation.

1 13. A system of Claim 1 wherein said image data storage and  
2 retrieval means comprises a data modem coupled to said image  
3 scanning and digitizing means, a write drive operatively  
4 coupled to said data modem to receive and to store said second  
5 digitized representation, and a plurality of data retrieval  
6 and transmission channels, each said and transmission] channel  
7 comprising an image data reader means operatively coupled to  
8 said telecommunication means to selectively receive said second  
9 digitized representation of said image for transmission to a  
10 said requesting remote visual display terminal.

1 14. A system of Claim 13 wherein a said image data reader means  
2 is operatively coupled to an external data write drive  
3 configured to receive a storage medium and to store compressed  
4 digital image data thereon.

1 15. A system of Claim 13 wherein said telecommunication means  
2 comprises a control computer operatively coupled to said image  
3 data storage and retrieval means to selectively control data  
4 flow between said image data storage and retrieval means and  
5 said remote visual display terminal and a plurality of data  
6 compression channels coupled to said control computer, wherein  
7 each said data compression channel comprises a data memory  
8 including means to decompress said low-loss second  
9 representation of said image data received from said data  
10 retrieval and transmission channel and a compression means  
11 including logic means to compress said decompressed second  
12 representation of said image data to form said third digitized  
13 representation of said image for transmission over said  
14 communication network to a said requesting remote visual

15 display terminal.

1 16. An automated high definition/resolution image storage,  
2 retrieval and transmission] system of Claim 15 wherein said  
3 data compression channel comprises display compatible  
4 resolution logic means including means to generate super  
5 pixels, said data compression channel acting to form a said  
6 third compressed digital representation, corresponding to said  
7 initially digitized image data whereby said telecommunication  
8 means acts to transmit data with a resolution compatible with a  
9 resolution limit of said requesting remote terminal.

1 17. A system of Claim 1 wherein said image digitizing means  
2 comprises means to digitize a said image from a video signal.

1 18. A system of Claim 1 wherein said image data storage and  
2 retrieval means includes at least one optical compact disk to  
3 store said second digitized representation received from said  
4 image scanning and digitizing means.

1 19. An automated high definition/resolution medical diagnostic  
2 image storage, retrieval and transmission system comprising

3 means to form an initial digitized image having a first  
4 resolution,

5 computer means to store said digitized image,

6 telecommunication means linking said computer means to

7 a remote visual display terminal capable of displaying a  
8 visual image with a second resolution no greater than a  
9 predetermined resolution limit, said terminal adapted to  
10 send a message via said telecommunication means to said  
11 computer means, said message comprising

12 an identification portion wherein said predetermined  
13 resolution limit is communicated to said computer

14 means and

15 a request for transmission of a said digitized image,

16 and

17 compression means associated with said telecommunication  
18 means and comprising display compatible resolution logic  
19 means acting to form a compressed digital representation  
20 corresponding to said initially digitized image data  
21 whereby said telecommunication means acts to transmit data  
22 with a resolution compatible with said requesting remote  
23 display terminal.

1 20. A system of Claim 19 wherein said compression means further  
2 includes logic means to generate a plurality of regions  
3 collectively representative of said image, each said region  
4 comprising a plurality of two dimensional, non-overlapping,  
5 symmetrically disposed super pixels and to compare each said  
6 region with a plurality of fictitious patterns, each said  
7 pattern having a dark region, a light region and a  
8 predetermined point of origin, to determine which of said  
9 plurality of fictitious patterns most closely correlates with  
10 said region and to generate a compressed digitized  
11 representation corresponding to said selected fictitious  
12 pattern, and wherein said remote visual display terminal  
13 includes means to generate and display an initial image  
14 corresponding to said fictitious pattern and having a third  
15 resolution less than said predetermined resolution limit.

1 21. A system of Claim 20 wherein said fictitious patterns are  
2 selected to be essentially uncorrelated with each other when  
3 rotated relative to each other.

1 22. A system of Claim 20 further including logic means to  
2 select a predetermined representative gray level most closely  
3 correlating with a gray level of a said super pixel.

1 23. A system of Claim 20 wherein said compression means further

2 includes progressive image enhancement means adapted to  
3 transmit, subsequent to said display of said initial image,  
4 data representative of exact gray levels of those super pixels  
5 located on a periphery of each said region and thereafter to  
6 transmit similar data for those super pixels interior to each  
7 said region whereby the resolution of said displayed image  
8 attains a value intermediate between said third resolution and  
9 said predetermined resolution limit.

1 24. A system of Claim 20 wherein said compression means further  
2 includes means to select a specific region of an image and to  
3 transmit digitized image data specific to said selected region  
4 to provide an expanded visual display of said selected region.

1 25. A system of Claim 20 wherein said compression means further  
2 includes run length compression of said fictitious patterns and  
3 wherein said remote visual display terminal includes means to  
4 generate and display an image corresponding to said fictitious  
5 pattern.

1 26. A system of Claim 19 wherein said compression means further  
2 includes logic means to generate a plurality of regions  
3 collectively representative of said image, each said region  
4 comprising a plurality of two dimensional, non-overlapping,  
5 symmetrically disposed super pixels and to compare each said  
6 region with a plurality of fictitious patterns, to determine  
7 which of said plurality of fictitious patterns most closely  
8 correlates with said region and to generate a compressed  
9 digitized representation corresponding to said selected  
10 fictitious pattern, and wherein said remote visual display  
11 terminal includes means to generate and display an image  
12 corresponding to said fictitious pattern and means to rotate  
13 said selected pattern to that one of a plurality of  
14 predetermined rotational orientations that most closely  
15 approximates said super pixel.

1 27. A system of Claim 19 wherein said compression means further  
2 includes logic means to generate a plurality of regions

3 collectively representative of said image, each said region  
4 comprising a plurality of two dimensional non-overlapping  
5 symmetrically disposed super pixels and to compare each said  
6 region with a plurality of fictitious patterns to determine  
7 which of said plurality of fictitious patterns most closely  
8 correlates with said region and to form a said compressed  
9 digital representation of said image corresponding to said  
10 selected fictitious pattern, and wherein said remote visual  
11 display terminal includes means to generate and display an  
12 image closely correlating to said actual super pixels in  
13 response to receiving said compressed digital representation  
14 corresponding to said selected fictitious patterns and logic  
15 means to generate a set of predetermined representative gray  
16 levels wherein each said gray level is that one most closely  
17 correlating with the gray levels of said actual super pixels.

1 28. A system of Claim 27 wherein said terminal means further  
2 comprises logic means to rotate a said selected pattern to that  
3 one of a plurality of predetermined rotational orientations  
4 that most closely approximates said actual super pixels.

1 29. A system of Claim 19 wherein said remote visual display  
2 terminal further includes image enhancement means to enhance a  
3 displayed image.

1 30. A system of Claim 29 wherein said image enhancement means  
2 includes logic means to enhance an edge contrast of a displayed  
3 image.

1 31. A system of Claim 29 wherein said image enhancement means  
2 includes logic means to enhance gray level contrast by means of  
3 gray level region expansion.

1 32. A system of Claim 29 wherein said image enhancement means  
2 includes logic means for differential gray level tracking and  
3 gray level enhancement.

1 33. A system of Claim 19 wherein said means to form an initial

2 digitized image includes an optical character reader.

1 34. An automated system adapted to store a plurality of high  
2 definition/resolution medical diagnostic images and to recon-  
3 struct and display ones of said images with progressive resolu-  
4 tion, said system comprising

5 first computer means adapted to store a digital represen-  
6 tation of a said image,

7 first telecommunication means operatively connected to  
8 said first computer means, said first telecommunication  
9 means comprising second computer means adapted to compress  
10 said digital representation of a said image and to store  
11 said compressed representation in a buffer memory means in  
12 a predetermined format chosen so that a first block of  
13 data from said buffer memory is usable to form a first  
14 reconstructed image having a first resolution and so that  
15 an incremental block of data from said buffer memory is  
16 usable, in combination with said data of said first block,  
17 to form a second reconstructed image having a second  
18 resolution greater than said first resolution,

19 remote terminal means comprising

20 second telecommunication means adapted for bi-direc-  
21 tional communication of messages to and from said  
22 first telecommunication means, said messages includ-  
23 ing said first and said incremental data blocks,

24 third computer means adapted to execute

25 a first algorithm capable of forming, from said  
26 data of said first block, said first recon-  
27 structed image,

28 a second algorithm capable of forming, from said  
29 data of said first block and said data of said



30 incremental block, a said second reconstructed  
31 image

32 display means adapted to display ones of said recon-  
33 structed images at a resolution less than a predeter-  
34 mined resolution limit.

1 35. A system of Claim 34 wherein said first telecommunication  
2 means is adapted to sequentially send ones of a plurality of  
3 said incremental blocks of data whereby said resolution of said  
4 displayed image increases with time.

1 36. A system of Claim 35 wherein said first telecommunication  
2 means is adapted to send no additional data when said  
3 resolution of said reconstructed image attains said resolution  
4 limit of said terminal.

1 37. A system of Claim 34 wherein said first telecommunication  
2 means further comprises means to enhance the gray scale of a  
3 said image and means

4 to transmit to said terminal means a said first data block  
5 usable to reconstruct a said image without said  
6 enhancement, and

7 to transmit to said terminal means a said incremental  
8 block usable to reconstruct said image with a said  
9 enhanced gray scale.

1 38. A system of Claim 37 wherein said means to enhance the gray  
2 scale of an image includes logic means to enhance an edge  
3 contrast of a displayed image.

1 39. A system of Claim 37 wherein said means to enhance the gray  
2 scale of an image includes logic means to enhance gray level  
3 contrast by means of gray level region expansion.

1 40. A system of Claim 37 wherein said means to enhance the gray

2 scale of an image includes logic means for differential gray  
3 level tracking and gray level enhancement.

1 41. A system of Claim 34 further comprising

2 user-operated interactive means operatively connected to  
3 said terminal means and acting to communicate to said  
4 third computer means coordinates of a bounded region of a  
5 said displayed image,

6 a third algorithm operative to transmit, via said second  
7 and said first telecommunication means to said second  
8 computer means, a said message including said co-ordinates  
9 of said bounded region,

10 a fourth algorithm operative to form, as a displayed  
11 image, a reconstructed image of said bounded region,

12 and wherein said predetermined format for said representation  
13 of said image stored in said second computer means is chosen so  
14 that a said incremental block of data is usable to increase the  
15 resolution of said reconstructed image of said bounded region.

1 42. A system of Claim 41 wherein said second computer means is  
2 adapted to sequentially send ones of a plurality of said  
3 incremental blocks of data whereby said resolution of said  
4 reconstructed bounded region of said image progressively  
5 increases.

1 43. A system of Claim 42 wherein said second computer means is  
2 adapted to send no additional data when said resolution of said  
3 reconstructed bounded region of said image attains said  
4 predetermined resolution limit of said terminal.

1 44. A system of Claim 34 wherein said first computer means  
2 further comprises means to store retrieval data adapted to  
3 uniquely associate a said image with a patient.

1 45. A method of acquiring, storing, retrieving and displaying a  
2 high definition/resolution medical diagnostic image comprising  
3 the steps of

4 a) acquiring a said image having a first resolution, and  
5 translating said image to a predetermined digital format,

6 b) storing said digitized image in a computer memory at a  
7 first location,

8 c) requesting, from a user-operated terminal having a  
9 first resolution limit and located at a second location, a  
10 said diagnostic image,

11 d) creating from said digitized image, at said first  
12 location, by means of a first algorithm, a patterned and  
13 compressed representation thereof,

14 e) transmitting from said first location to said terminal  
15 a first portion of said stored patterned representation,

16 f) reconstructing, at said terminal, by means of a second  
17 algorithm, from said first portion of said patterned  
18 representation, a first displayable representation of said  
19 diagnostic image, said first displayable representation  
20 having a second resolution less than said first  
21 resolution,

22 g) displaying said displayable representation at said  
23 terminal,

24 h) transmitting from said first location to said terminal  
25 an additional portion of said patterned representation,

26 i) reconstructing, at said terminal, by means of a third  
27 algorithm, from said additional portion of said patterned  
28 representation, an improved displayable representation of  
29 said image, said improved displayable representation

30 having a third resolution greater than said second  
31 resolution,

32 j) repeating steps g), h) and i), thereby progressively  
33 increasing the resolution of said displayed representation  
34 until said displayed resolution attains the lesser of

35 said first resolution of said image or

36 said predetermined resolution limit of said terminal.

1 46. A method of Claim 45 including an additional step of

2 k) enhancing, by means of a fourth algorithm, a displayed  
3 representation.

1 47. A method of Claim 46 wherein said fourth algorithm  
2 comprises enhancing an edge contrast of a displayed  
3 representation.

1 48. A method of Claim 46 wherein said fourth algorithm  
2 comprises enhancing a gray level contrast by means of gray  
3 level region expansion.

1 49. A method of Claim 46 wherein said fourth algorithm  
2 comprises differential gray level tracking and gray level  
3 enhancement.

1 50. A method of Claim 45 wherein said step of acquiring a said  
2 image comprises scanning a diagnostic film to form a digital  
3 representation thereof.

1 51. A method of Claim 45 further comprising additional steps of

2 acquiring, with said diagnostic image, retrieval data  
3 adapted to uniquely associate said image with a patient,  
4 and  
5 storing said retrieval data in said computer memory.

1 52. A method of Claim 45 further comprising an additional step  
2 after step g) of defining, by means of a user-operated  
3 computer-interactive device, a sub-image of said visual  
4 representation, and  
5 wherein said subsequent reconstructions in step j) are directed  
6 at reconstruction only of said sub-image.

1 53. A method of Claim 45 wherein said step of acquiring said  
2 image and forming a digitized representation thereof further  
3 includes a step of compressing said image by means of a run  
4 length compression algorithm.

1 54. A method of Claim 45 wherein said first algorithm comprises  
2 a hexagonal pattern classification.

1 55. A method of Claim 45 wherein said predetermined digital  
2 format formed in step a) comprises a compressed digital image,  
3 and wherein said first algorithm re-expands said compressed  
4 digital image before forming said patterned and compressed  
5 representation therefrom.

1 56. A method of Claim 45 wherein said step of acquiring an  
2 image comprises digitizing a video signal.

1 57. An automated high definition/resolution medical diagnostic  
2 image storage, retrieval and transmission system comprising

3 means to form an initial digitized image,

4 computer means to store said digitized image,

5 telecommunication means linking said computer means to a  
6 remote visual display terminal capable of displaying a  
7 visual image, said telecommunication means comprising  
8 compression means including logic means to

9 generate a plurality of regions collectively  
10 representative of said image, each said region

11 comprising a plurality of two dimensional, non-  
12 overlapping, symmetrically disposed super pixels and  
13 to

14 compare each said region with a plurality of  
15 fictitious patterns, each said pattern having a dark  
16 region, a light region and a predetermined point of  
17 origin, and thereby to determine which of said  
18 plurality of fictitious patterns most closely  
19 correlates with said region and to generate a  
20 compressed digitized representation corresponding to  
21 said selected fictitious pattern, and

22 wherein said remote visual display terminal includes means to  
23 generate and display an image corresponding to said fictitious  
24 pattern.

1 58. A system of Claim 57 wherein said fictitious patterns are  
2 selected to be essentially uncorrelated with each other when  
3 rotated relative to each other.

1 59. A system of Claim 58 further including logic means to  
2 select a fictitious pattern having a gray level most closely  
3 correlating with a gray level of a said super pixel.

1 60. A system of Claim 57 wherein said compression means further  
2 includes logic means to determine which of said plurality of  
3 fictitious patterns most closely correlates with said region  
4 and to generate a compressed digitized representation  
5 corresponding to said selected fictitious pattern, and wherein  
6 said remote visual display terminal includes means to generate  
7 and display an image corresponding to said fictitious pattern  
8 and means to rotate said selected pattern to that one of a  
9 plurality of predetermined rotational orientations that most  
10 closely approximates said super pixel.

1 61. A system of Claim 57 wherein said remote visual display  
2 terminal includes means to generate and display an image

3 closely correlating to said actual super pixel in response to  
4 receiving said compressed digitized image data corresponding to  
5 said selected fictitious patterns and logic means to generate a  
6 set of predetermined representative gray levels wherein each  
7 said gray level is that one most closely correlating with the  
8 gray levels of said actual super pixels.

1 62. A system of Claim 61 wherein said terminal means further  
2 comprises logic means to rotate a said selected pattern to that  
3 one of a plurality of predetermined rotational orientations  
4 that most closely approximates said actual super pixels.

1 63. A system of Claim 57 wherein said telecommunication means  
2 further includes means to compress and transmit to said remote  
3 terminal digitized image data specific to a selected sub-image  
4 and wherein said remote terminal further comprises means to  
5 provide visual display of said selected sub-image.

1 64. A system of Claim 63 wherein said compression means further  
2 includes progressive image enhancement means adapted to  
3 transmit, subsequent to a display of a said selected sub-image,  
4 data representative of exact gray levels of those super pixels  
5 located on a periphery of each region within said selected sub-  
6 image and thereafter to transmit similar data for those super  
7 pixels interior to each said region, whereby the resolution of  
8 said displayed sub-image increases with time.

1 65. A system of Claim 64 wherein said terminal has a resolution  
2 limit and wherein said terminal comprises means to communicate  
3 said resolution limit to said telecommunication means, and  
4 wherein said telecommunication means is adapted to send no  
5 additional data when the resolution of said displayed sub-image  
6 attains said resolution limit.

1 66. A system of Claim 57 wherein said compression means further  
2 includes run length compression of said fictitious patterns.

1 67. A system of Claim 57 wherein said remote visual display

2 terminal further includes image enhancement means to enhance a  
3 displayed image.

1 68. A system of Claim 67 wherein said image enhancement means  
2 includes logic means to enhance an edge contrast of a displayed  
3 image.

1 69. A system of Claim 67 wherein said image enhancement means  
2 includes logic means to enhance gray level contrast by means of  
3 gray level region expansion.

1 70. A system of Claim 67 wherein said image enhancement means  
2 includes logic means for differential gray level tracking and  
3 gray level enhancement.



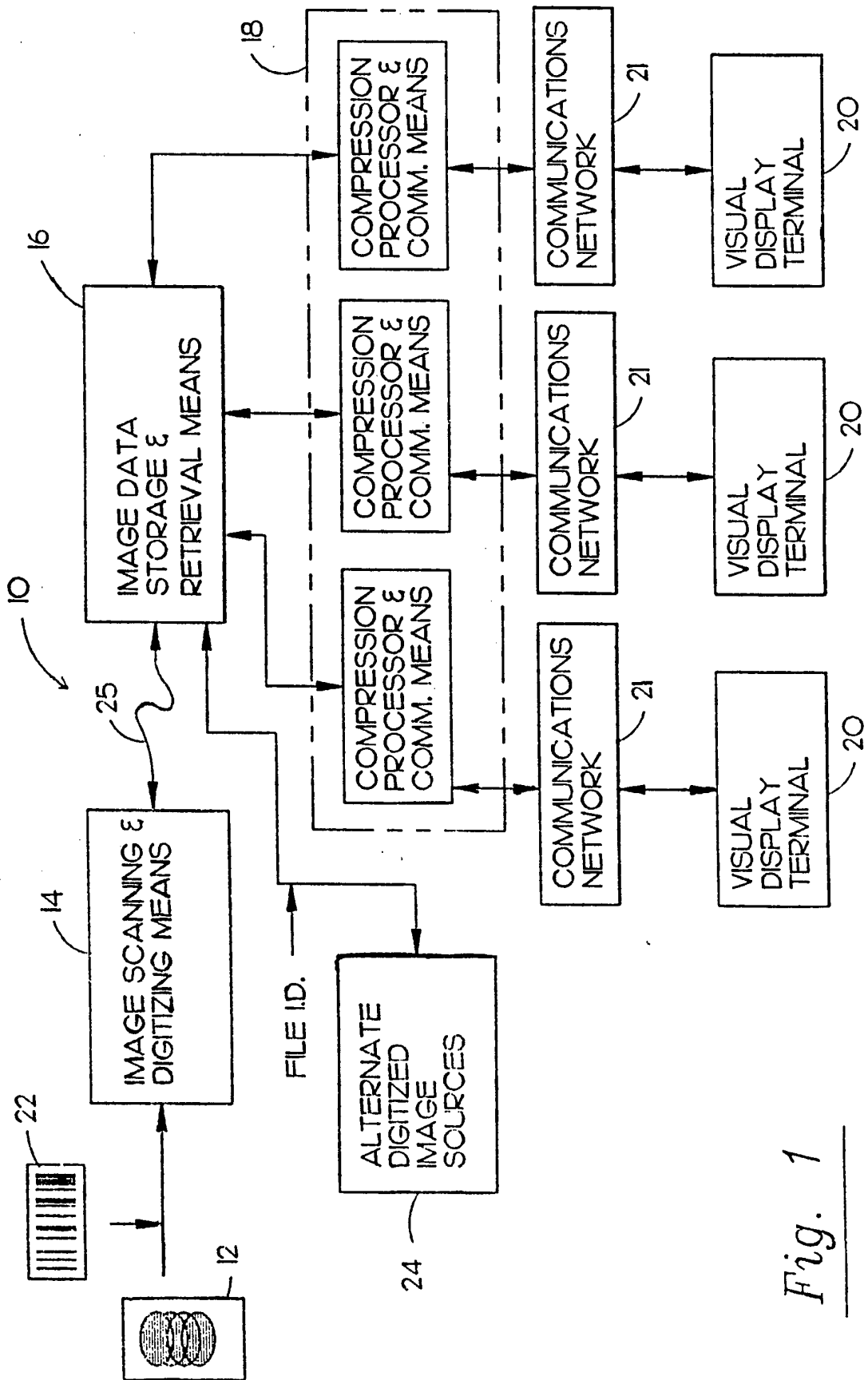

Fig. 1

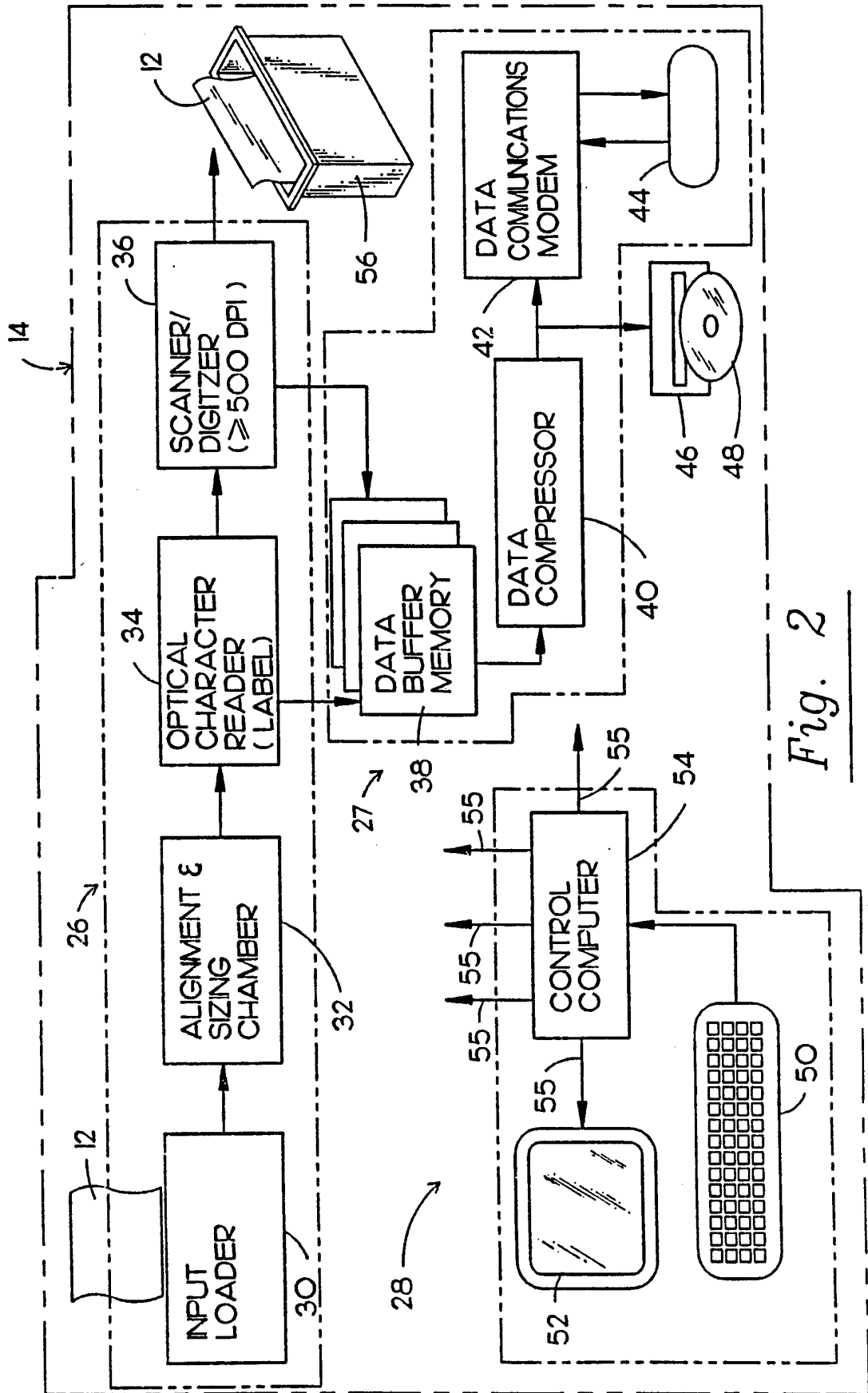

Fig. 2



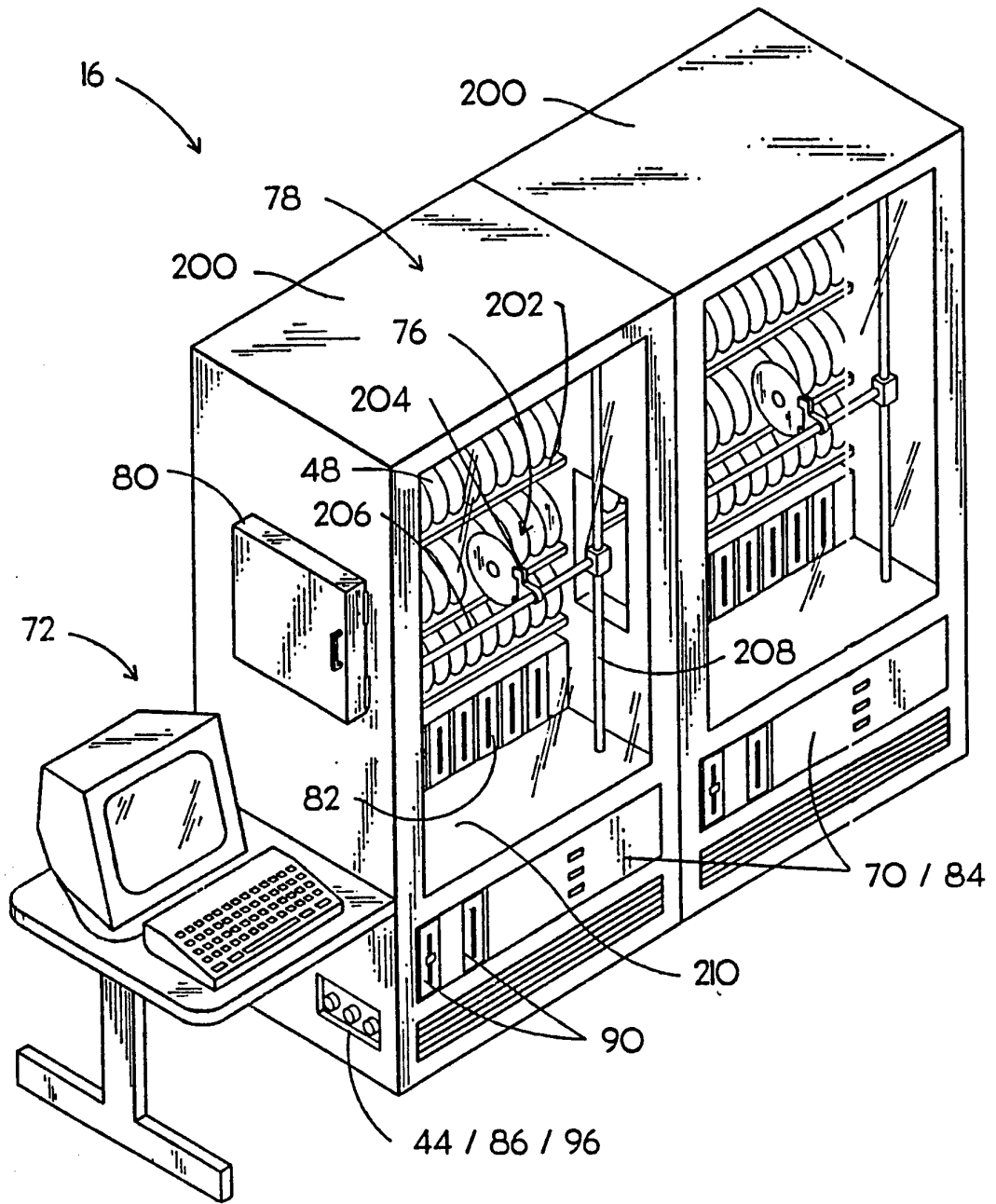

Fig. 4

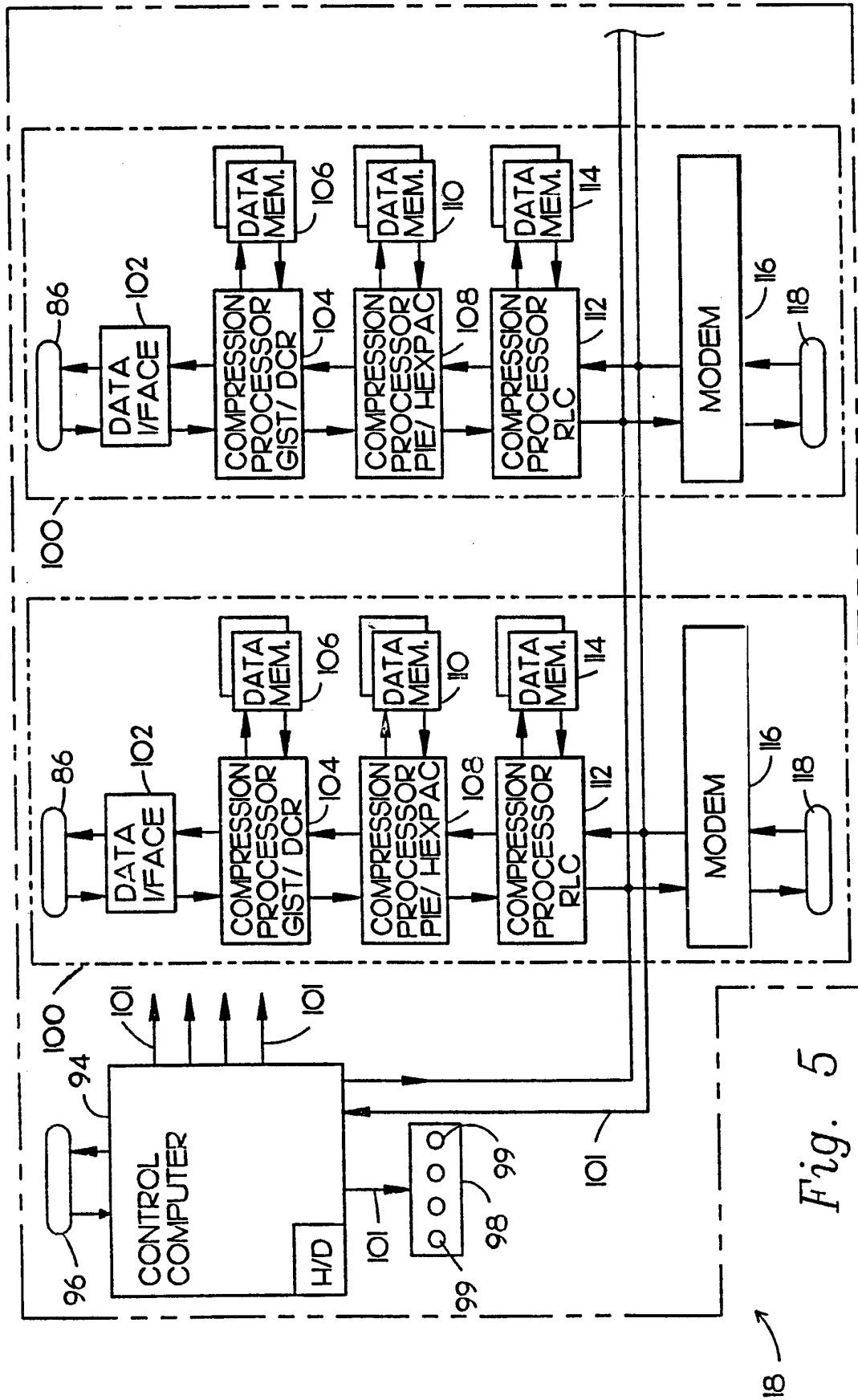

Fig. 5

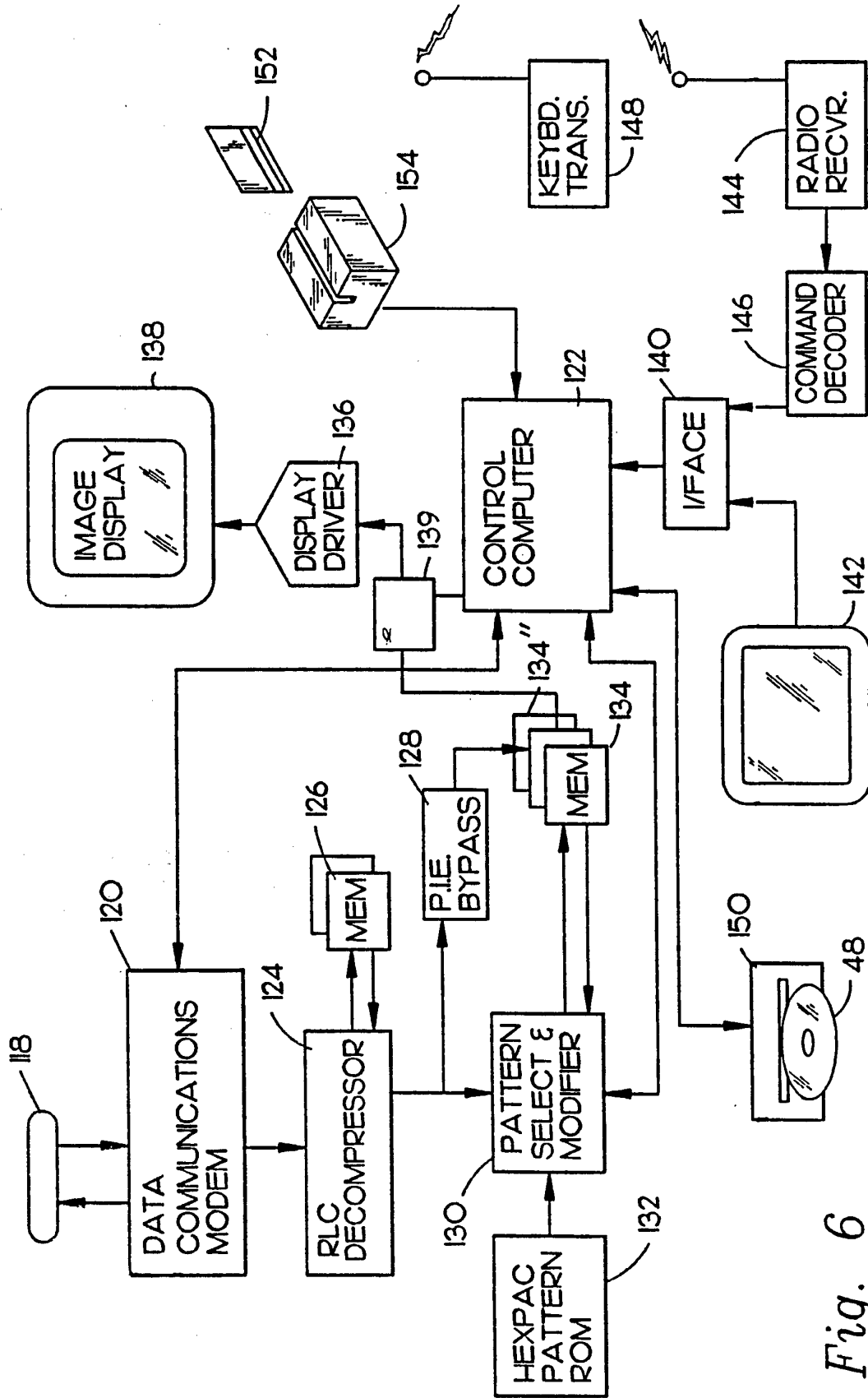

Fig. 6

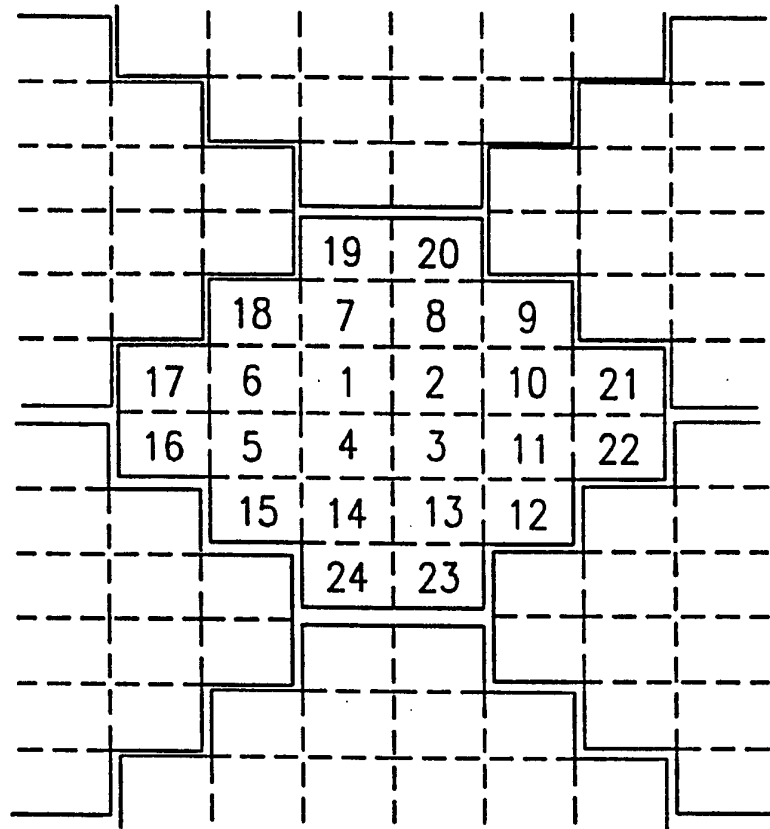

Fig. 7

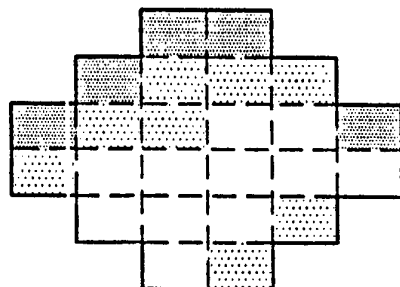

Fig. 8

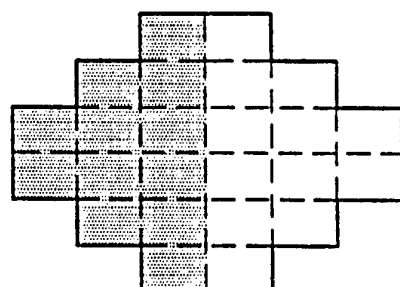

Fig. 9

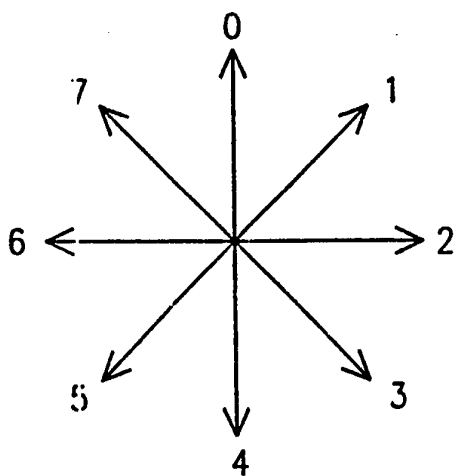

Fig. 10

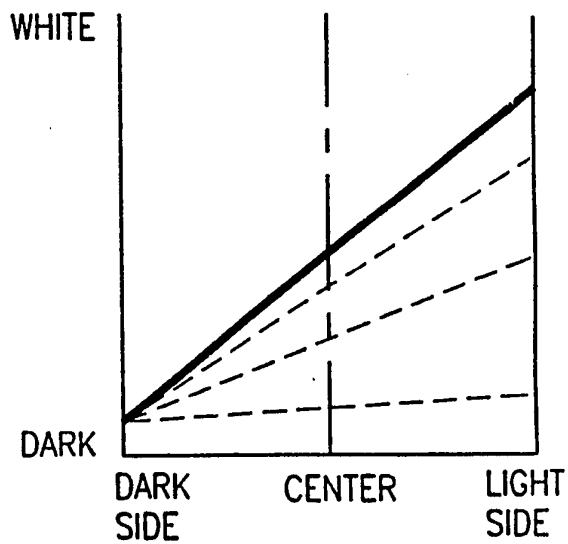

Fig. 11



Fig. 12

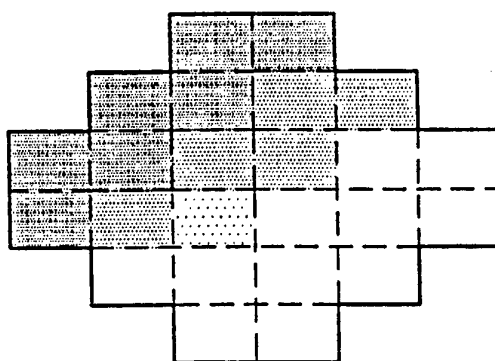

Fig. 13



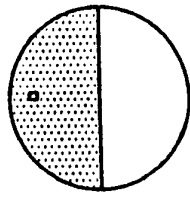

Fig. 14-A

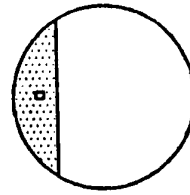

Fig. 14-B

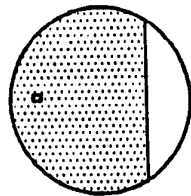

Fig. 14-C

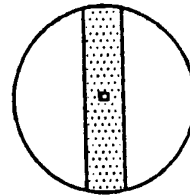

Fig. 14-D

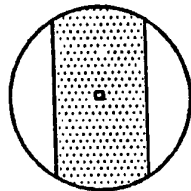

Fig. 14-E

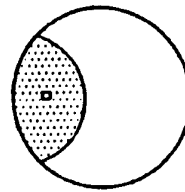

Fig. 14-F

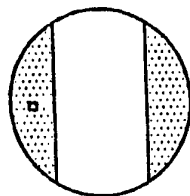

Fig. 14-G

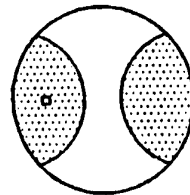

Fig. 14-H

## INTERNATIONAL SEARCH REPORT

International application No.  
PCT/US93/06042**A. CLASSIFICATION OF SUBJECT MATTER**

IPC(5) :H04N 1/04, 1/21, 1/32, 1/387, 1/393, 1/41, 1/419

US CL :Please See Extra Sheet.

According to International Patent Classification (IPC) or to both national classification and IPC

**B. FIELDS SEARCHED**

Minimum documentation searched (classification system followed by classification symbols)

U.S. : Please See Extra Sheet.

Documentation searched other than minimum documentation to the extent that such documents are included in the fields searched

Electronic data base consulted during the international search (name of data base and, where practicable, search terms used)

**C. DOCUMENTS CONSIDERED TO BE RELEVANT**

Category*	Citation of document, with indication, where appropriate, of the relevant passages	Relevant to claim No.
Y	US, A, 4,772,955 (Kurahayashi et al) 20 September 1988, Figs.11-13	1-70
Y	US, A, 4,719,514 (Kurahayashi et al) 12 January 1988, see Abstract, Summary, and Figure 3.	1-70
Y	US, A, 5,068,745 (Shimura) 26 November 1991, see Column 2-4, line 1-19.	15-16
A	US, A, 4,264,808 (Owens et al) 28 April 1981, see abstract and figure 1.	1-70
A	US, A, 4,768,099 (Mukai) 30 August 1988, see abstract and figure 1.	1-70
A	US, A, 4,817,050 (Komatsu et al) 28 March 1989, see abstract.	1-70



Further documents are listed in the continuation of Box C.



See patent family annex.

* Special categories of cited documents:	"T" later document published after the international filing date or priority date and not in conflict with the application but cited to understand the principle or theory underlying the invention
"A" document defining the general state of the art which is not considered to be part of particular relevance	"X" document of particular relevance; the claimed invention cannot be considered novel or cannot be considered to involve an inventive step when the document is taken alone
"E" earlier document published on or after the international filing date	"Y" document of particular relevance; the claimed invention cannot be considered to involve an inventive step when the document is combined with one or more other such documents, such combination being obvious to a person skilled in the art
"L" document which may throw doubts on priority claim(s) or which is cited to establish the publication date of another citation or other special reason (as specified)	"&" document member of the same patent family
"O" document referring to an oral disclosure, use, exhibition or other means	
"P" document published prior to the international filing date but later than the priority date claimed	

Date of the actual completion of the international search

28 September 1993

Date of mailing of the international search report

DEC 02 1993

Name and mailing address of the ISA/US  
Commissioner of Patents and Trademarks  
Box PCT  
Washington, D.C. 20231

Authorized officer

SCOTT ROGERS

Facsimile No. (703) 305-9508

Telephone No. (703) 305-4726

## INTERNATIONAL SEARCH REPORT

International application No.  
PCT/US93/06042

C (Continuation). DOCUMENTS CONSIDERED TO BE RELEVANT

Category*	Citation of document, with indication, where appropriate, of the relevant passages	Relevant to claim No.
A	US, A, 4,910,609 (Nicholas et al) 20 March 1990, see abstract.	1-70
Y	US, A, 5,111,306 (Kanno et al) 05 May 1992, see column 2, lines 12-59.	1-70
Y,P	US, A, 5,170,266 (Marsh et al) 08 December 1992, see column 3-4, lines 9-19.	1-70

INTERNATIONAL SEARCH REPORT

International application No.  
PCT/US93/06042

A. CLASSIFICATION OF SUBJECT MATTER:

US CL :

358/403, 426, 261.1, 434, 442, 444, 447, 451, 453, 455, 487, 506, 528, 532, 538, 539; 382/54, 56

B. FIELDS SEARCHED

Minimum documentation searched

Classification System: U.S.

358/403, 426, 261.1, 429, 434, 442, 444, 447, 451, 453, 455, 487, 506, 528, 532, 538, 539; 382/54, 56;

Classification System: IPC(5)

H04N 1/04, 1/21, 1/32, 1/387, 1/393, 1/41, 1/419