



(12) **United States Design Patent**
Wong et al.

(10) **Patent No.:** **US D779,432 S**
(45) **Date of Patent:** **** Feb. 21, 2017**

(54) **SENSOR AND CONNECTOR**

(57) **CLAIM**

(71) Applicant: **Covidien LP**, Mansfield, MA (US)
(72) Inventors: **Alissa K. Wong**, Boulder, CO (US);
Timothy W. Fries, Louisville, CO (US)

We claim the ornamental design for a sensor and connector, as shown and described.

(73) Assignee: **Covidien LP**, Mansfield, MA (US)

(**) Term: **15 Years**

DESCRIPTION

(21) Appl. No.: **29/539,745**

(22) Filed: **Sep. 17, 2015**

(51) **LOC (10) Cl.** **13-03**

(52) **U.S. Cl.**
USPC **D13/133**; D10/97; D24/186

(58) **Field of Classification Search**
USPC D10/78, 81, 97; D13/133; D14/433;
D24/186, 187, 168, 169
(Continued)

FIG. 1 is a perspective view of the sensor and connector of the present invention;
FIG. 2 is a top view of the sensor and connector of FIG. 1;
FIG. 3 is a bottom view of the sensor and connector of FIG. 1;
FIG. 4 is a right side view of the sensor and connector of FIG. 1;
FIG. 5 is a left side view of the sensor and connector of FIG. 1;
FIG. 6 is a front view of the sensor and connector of FIG. 1;
FIG. 7 is a rear view of the sensor and connector of FIG. 1;
FIG. 8 is a perspective view of an alternate embodiment of the sensor and connector;
FIG. 9 is a top view of the sensor and connector of FIG. 8;
FIG. 10 is a left or right side view of the sensor and connector of FIG. 8;
FIG. 11 is a perspective view of an alternate embodiment of the sensor and connector;
FIG. 12 is a top view of the sensor and connector of FIG. 11;
FIG. 13 is a right side view of the sensor and connector of FIG. 11;
FIG. 14 is a perspective view of an alternate embodiment of the sensor and connector;
FIG. 15 is a top view of the sensor and connector of FIG. 14;
FIG. 16 is a left or right side view of the sensor and connector of FIG. 14; and,
FIG. 17 is a perspective view of an alternate embodiment of the sensor and connector.

(56) **References Cited**

U.S. PATENT DOCUMENTS

4,964,408 A * 10/1990 Hink A61B 5/14552
600/344
5,069,213 A 12/1991 Polczynski
(Continued)

FOREIGN PATENT DOCUMENTS

EP 1945099 7/2008
JP 6016774 3/1994
(Continued)

OTHER PUBLICATIONS

INVOS Cerebral/Somatic Oximeter, Reflects Site-Specific Tissue Perfusion Noninvasively, 11-PM-0258 mn21410; 883-11-PM-0258BRC_INVOSNeonatalBrochure-singles-1320864559 (2010).
(Continued)

Any subject matter shown in broken lines in the drawings constitutes the environment only and forms no part of the protection sought. The article is shown with a symbolic break in its length. The appearance of any portion of the article between the break lines forms no part of the claimed design.

Primary Examiner — Antoine D Davis

1 Claim, 11 Drawing Sheets

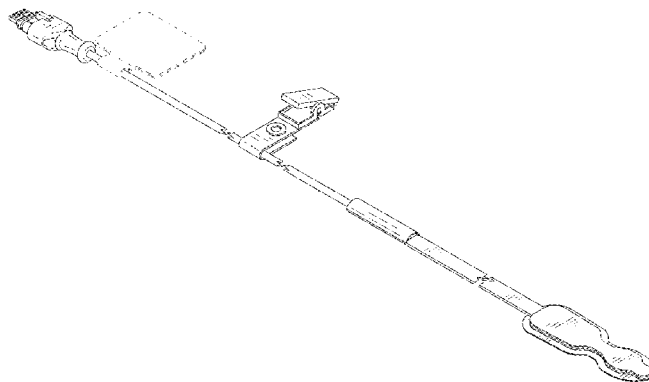

(58) **Field of Classification Search**

CPC	A61B 5/14551; A61B 5/14552; A61B 5/14553; A61B 5/6813; A61B 5/6814; A61B 5/6815; A61B 5/6816; A61B 5/6817; A61B 5/6819; A61B 5/682; A61B 5/6821; A61B 5/6822; A61B 5/6823; A61B 5/6824; A61B 5/6825	7,117,590 B2 7,132,641 B2 7,210,959 B1 7,225,006 B2 7,248,910 B2 7,371,981 B2 7,377,794 B2 7,427,165 B2 8,188,433 B2*	10/2006 11/2006 5/2007 5/2007 7/2007 5/2008 5/2008 9/2008 5/2012	Koenig et al. Schulz et al. Teves Al-Ali et al. Li et al. Abdul-Hafiz Al-Ali et al. Benaron et al. Gonopolskiy	A61B 5/14552 250/338.1
-----------	---	---	--	--	---------------------------

See application file for complete search history.

(56) **References Cited**

U.S. PATENT DOCUMENTS

5,154,175	A	10/1992	Gunther	
5,228,440	A	7/1993	Chung et al.	
5,249,576	A	10/1993	Goldberger et al.	
5,287,853	A	2/1994	Vester et al.	
5,343,869	A	9/1994	Pross et al.	
5,387,122	A	2/1995	Goldberger et al.	
5,425,362	A	6/1995	Siker et al.	
5,491,299	A	2/1996	Naylor et al.	
5,645,440	A	7/1997	Tobler et al.	
5,660,567	A	8/1997	Nierlich et al.	
5,743,260	A	4/1998	Chung et al.	
5,790,729	A	8/1998	Pologe et al.	
5,851,178	A	12/1998	Aronow	
5,890,929	A	4/1999	Mills et al.	
5,934,925	A	8/1999	Tobler et al.	
5,961,452	A	10/1999	Chung et al.	
5,997,343	A	12/1999	Mills et al.	
6,014,576	A	1/2000	Raley	
6,026,312	A	2/2000	Shemwell et al.	
6,112,107	A	8/2000	Hannula	
6,152,754	A	11/2000	Gerhardt et al.	
6,165,005	A	12/2000	Mills et al.	
6,253,097	B1	6/2001	Aronow et al.	
6,280,213	B1	8/2001	Tobler et al.	
6,370,409	B1	4/2002	Chung et al.	
6,466,809	B1*	10/2002	Riley	A61B 5/14552 600/344
6,541,756	B2	4/2003	Schultz et al.	
6,678,543	B2	1/2004	Diab et al.	
6,850,788	B2	2/2005	Al-Ali	

2002/0103423	A1	8/2002	Chin et al.
2003/0135099	A1	7/2003	Al-Ali
2003/0162414	A1	8/2003	Schulz et al.
2004/0267103	A1	12/2004	Li et al.
2005/0113704	A1	5/2005	Lawson et al.
2006/0211932	A1	9/2006	Al-Ali et al.
2006/0241363	A1	10/2006	Al-Ali et al.
2007/0123783	A1	5/2007	Chang
2008/0064940	A1	3/2008	Raridan
2008/0071153	A1	3/2008	Al-Ali et al.
2008/0076980	A1	3/2008	Hoarau
2008/0076995	A1	3/2008	Hoarau
2008/0076996	A1	3/2008	Hoarau
2008/0081954	A1	4/2008	Meyer et al.
2008/0220633	A1	9/2008	Al-Ali et al.
2008/0255435	A1	10/2008	Al-Ali et al.
2008/0316488	A1	12/2008	Mao et al.

FOREIGN PATENT DOCUMENTS

JP	24329406	11/2004
JP	25052385	3/2005
JP	25110816	4/2005
JP	26061566	3/2006
JP	27117641	5/2007
JP	27167183	7/2007
JP	27167184	7/2007
JP	27190122	8/2007

OTHER PUBLICATIONS

A monitor designed to help treat a range of complex patients; 12673-DesignedtoTreat-1402592390 (2012 INVOS brochure).

* cited by examiner

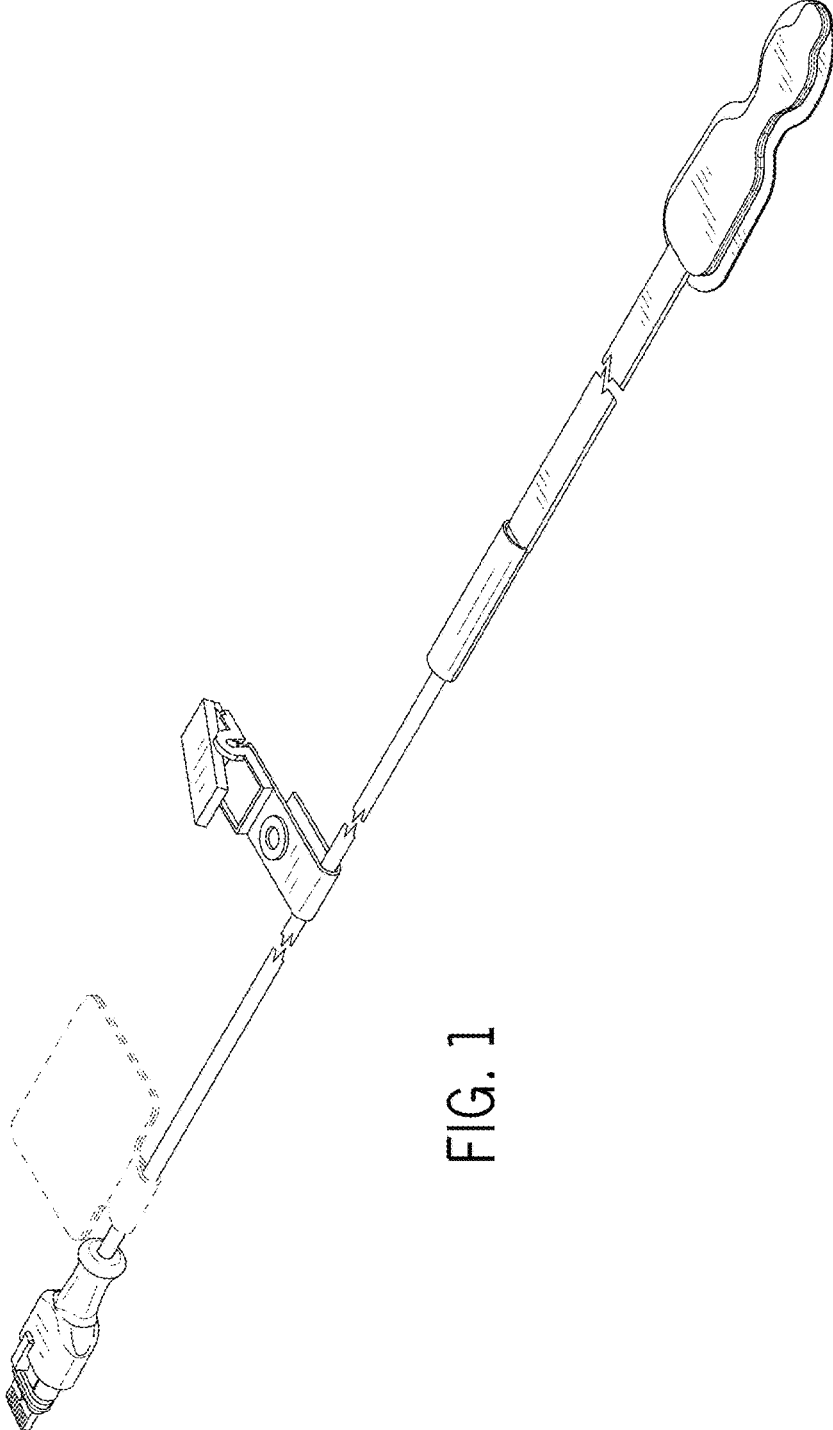

FIG. 1

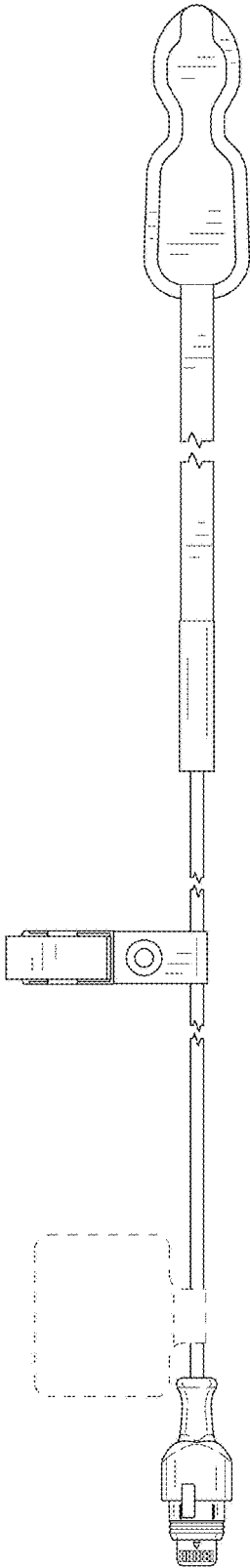

FIG. 2

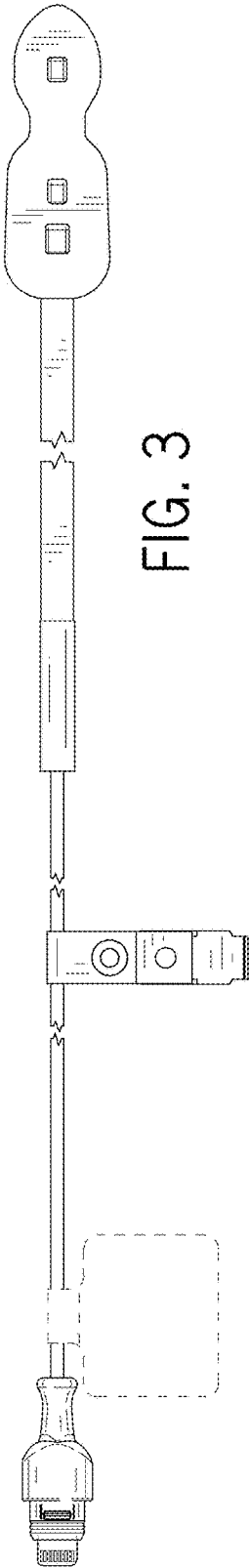

FIG. 3

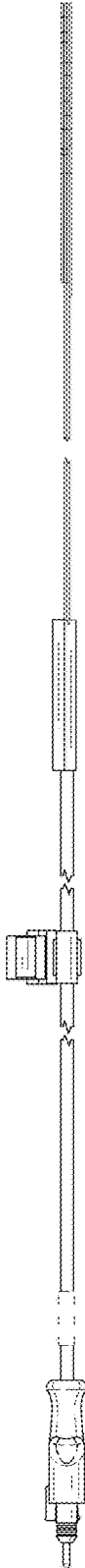

FIG. 4

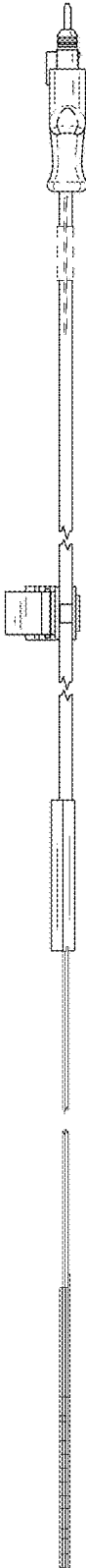

FIG. 5

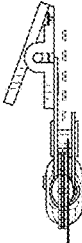

FIG. 6

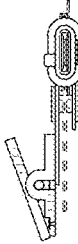

FIG. 7

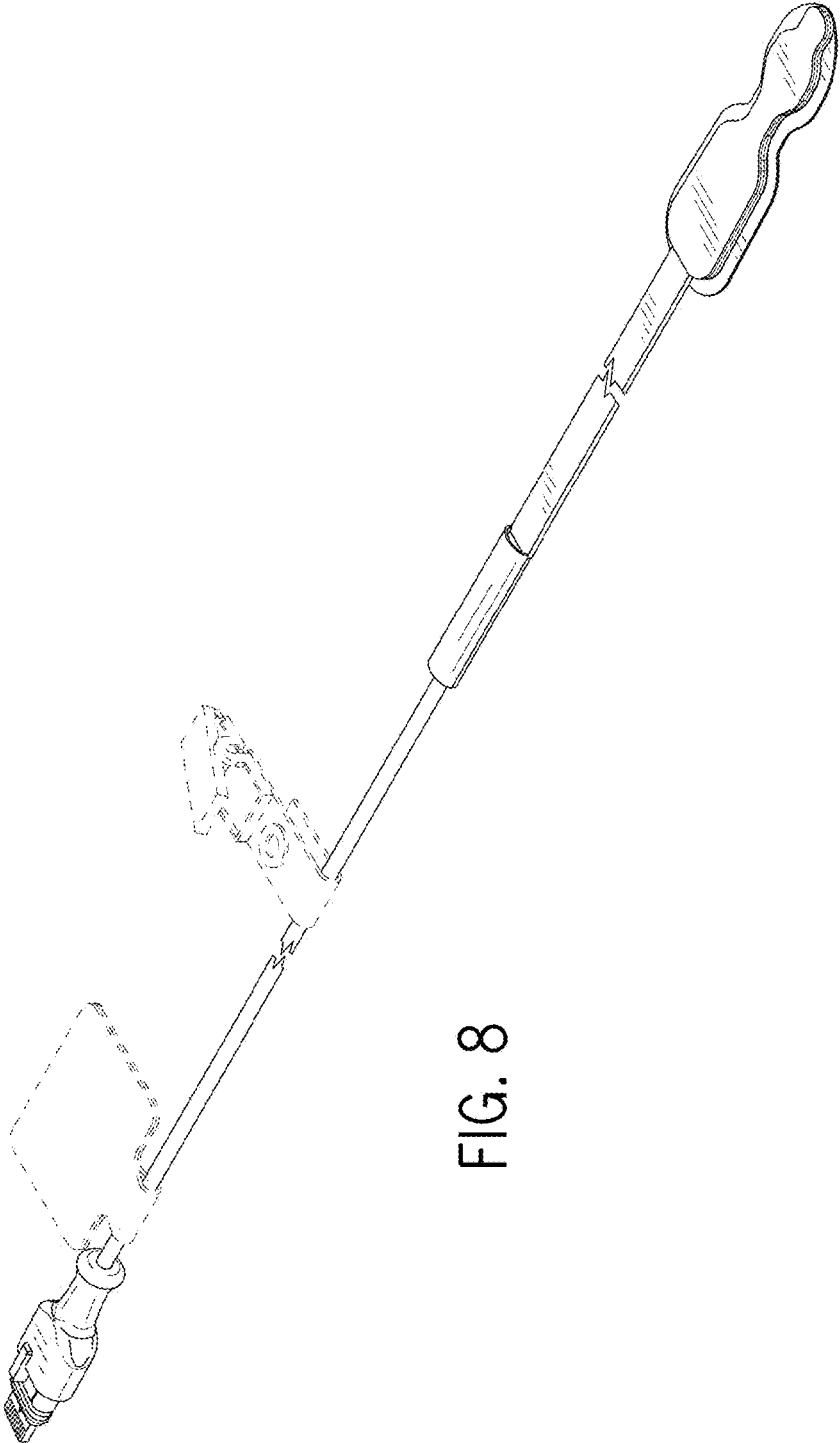

FIG. 8

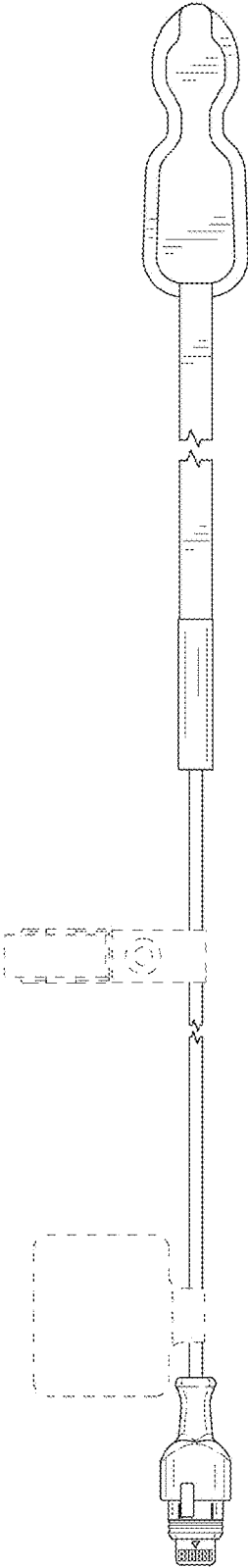

FIG. 9

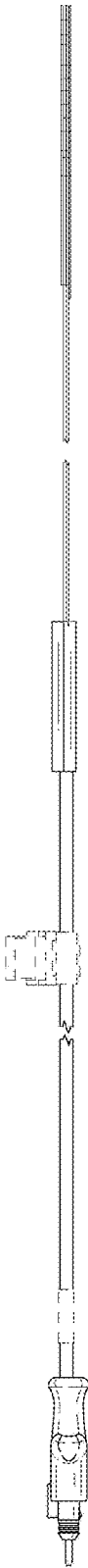

FIG. 10

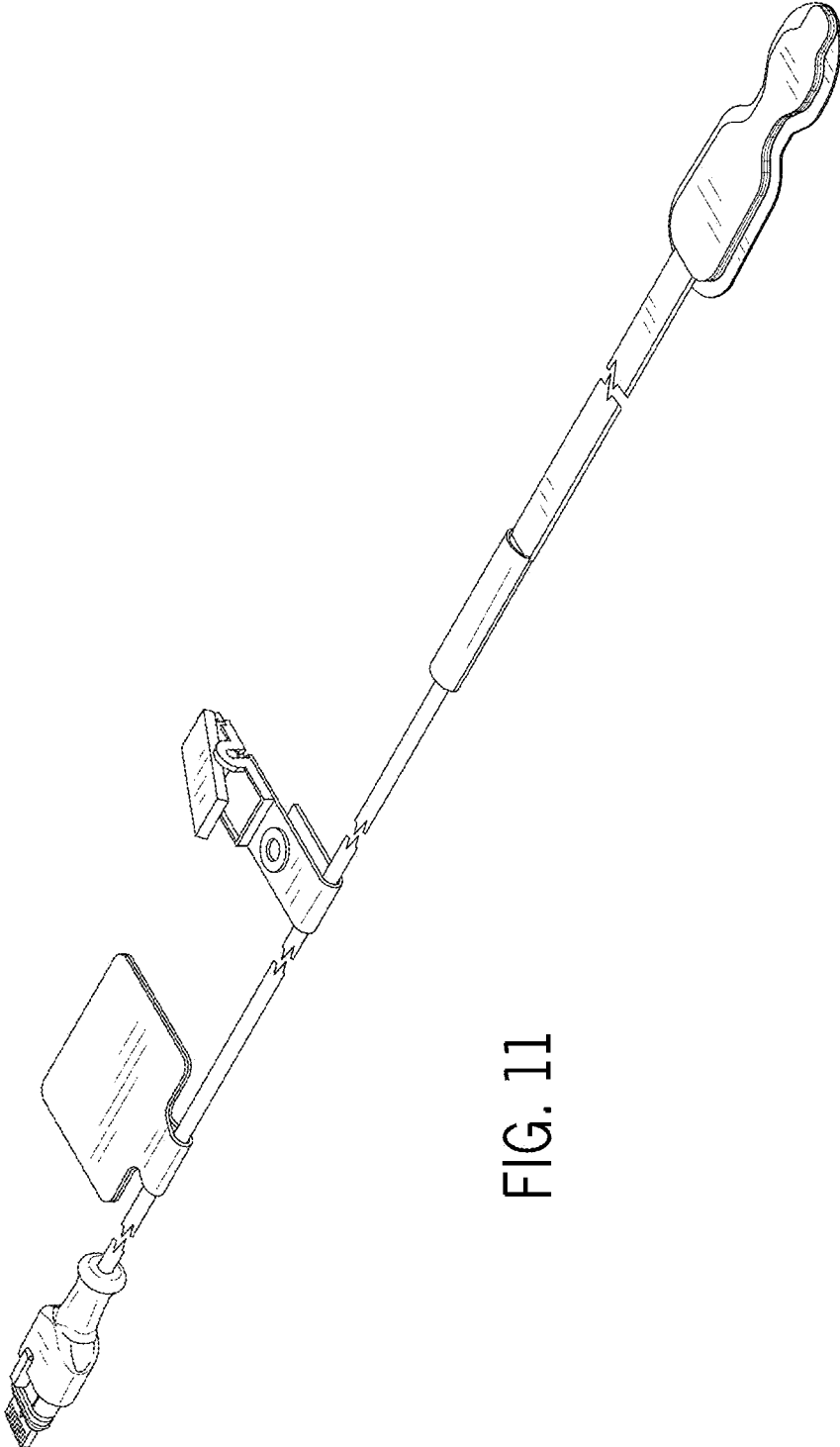

FIG. 11

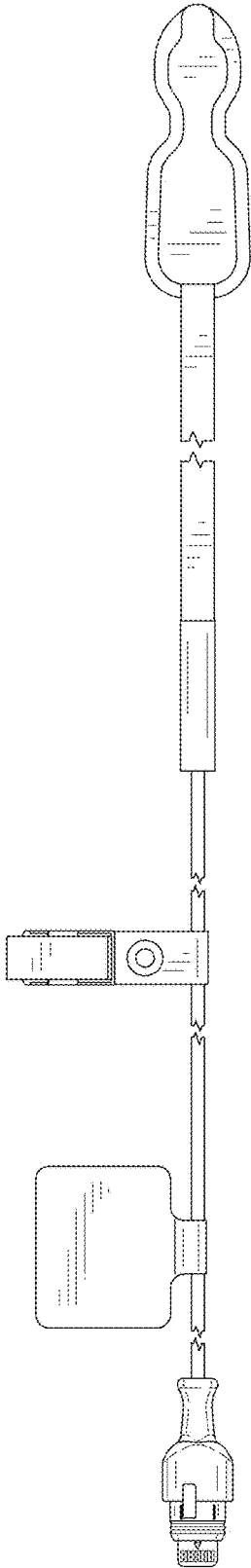

FIG. 12

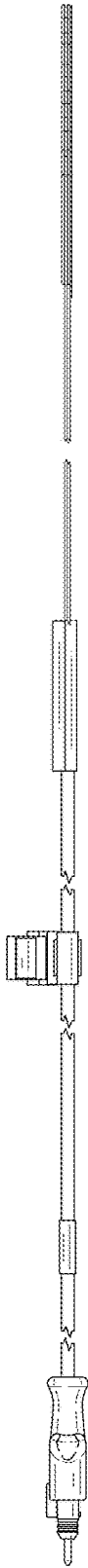

FIG. 13

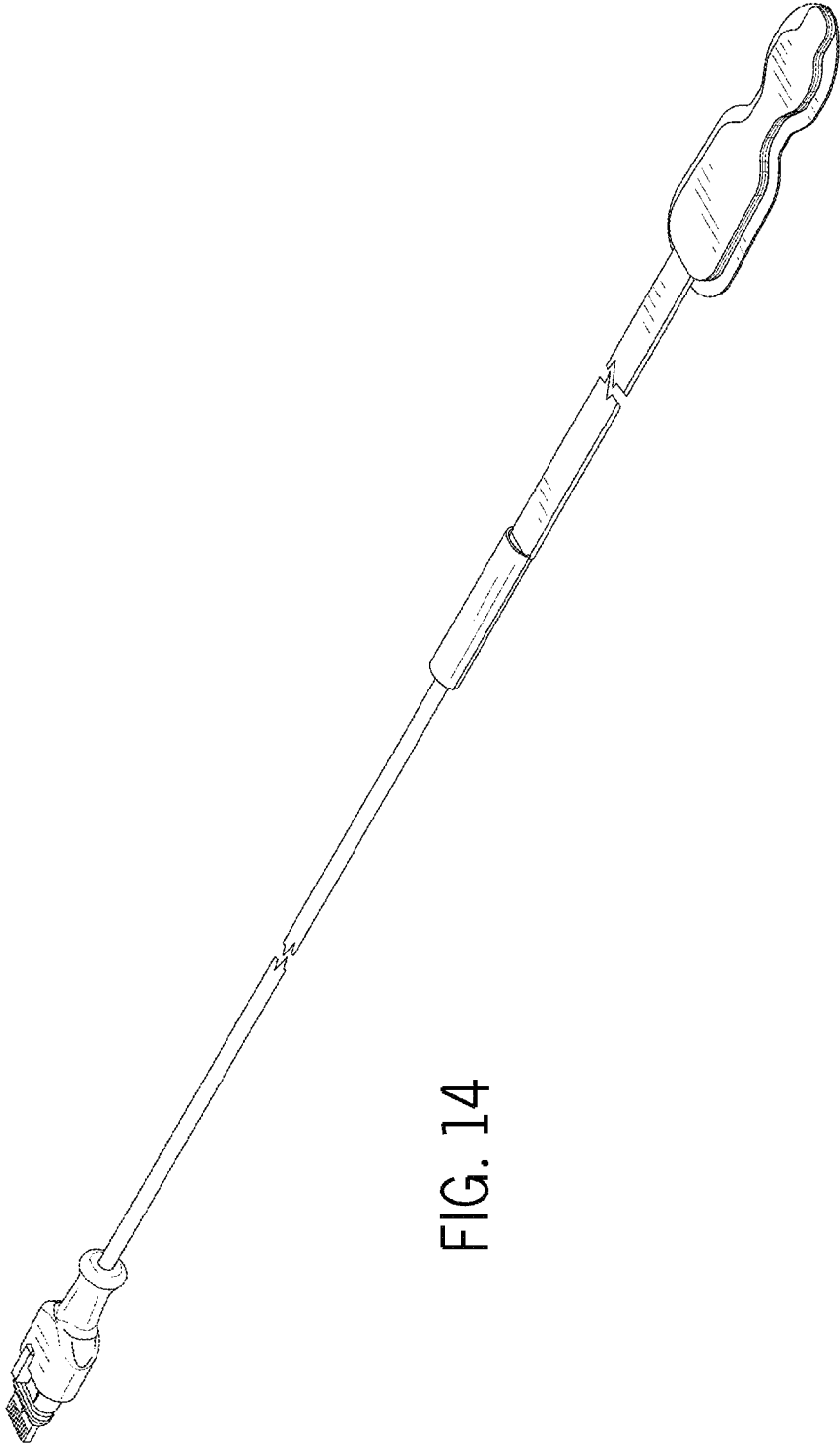

FIG. 14

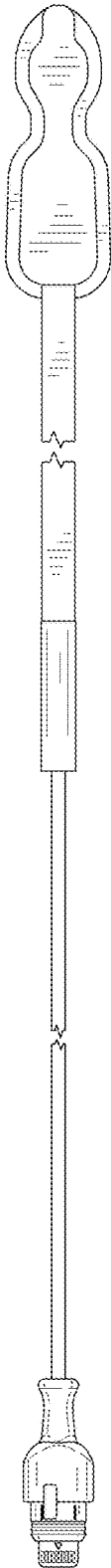

FIG. 15

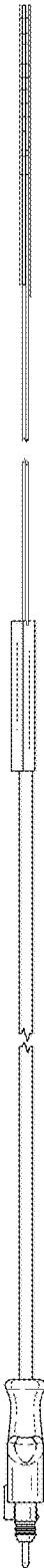

FIG. 16

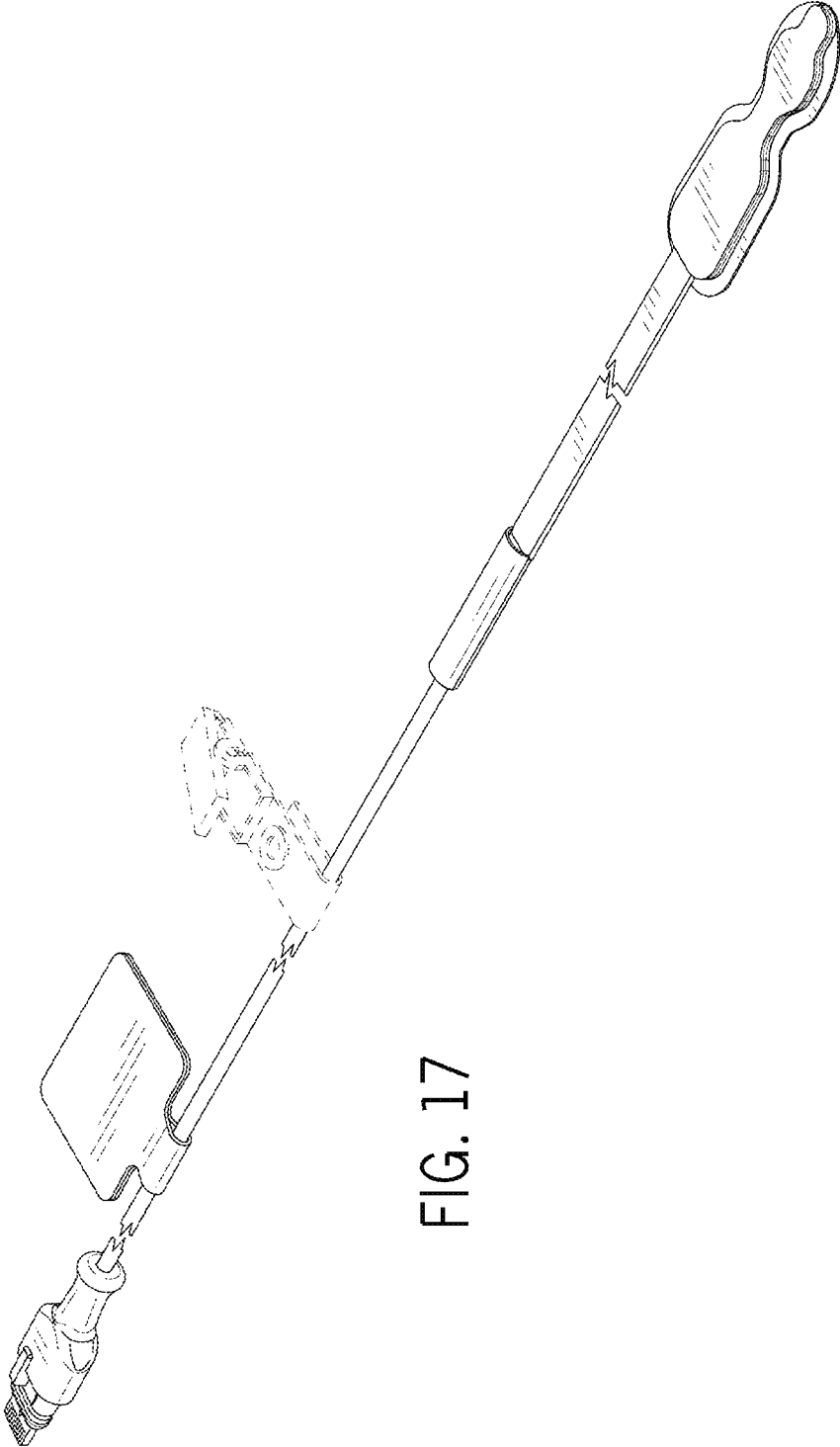

FIG. 17