



(19) **United States**

(12) **Patent Application Publication**
Snawerdt

(10) **Pub. No.: US 2002/0131106 A1**

(43) **Pub. Date: Sep. 19, 2002**

(54) **SECURE WAVE-DIVISION MULTIPLEXING TELECOMMUNICATIONS SYSTEM AND METHOD**

(52) **U.S. Cl. 359/124; 359/154**

(76) **Inventor: Peter Snawerdt, Melbourne Beach, FL (US)**

(57) **ABSTRACT**

Correspondence Address:
DAVIDSON, DAVIDSON & KAPPEL, LLC
485 SEVENTH AVENUE, 14TH FLOOR
NEW YORK, NY 10018 (US)

A fiber optic data transmission system includes an optical fiber and a data transmitter having a first laser having a first wavelength, a first phase modulator for phase modulating light from the first laser as a function of a first data input stream so as to create a first phase-modulated output data stream, a second laser having a second wavelength different from the first wavelength, and a second phase modulator for phase modulating light from the second laser as a function of a second data input stream so as to create a second phase-modulated output data stream. The transmitter also includes a combiner combining the first and second output data streams into a phase-modulated optical signal for transmission over the optical fiber.

(21) **Appl. No.: 09/809,936**

(22) **Filed: Mar. 16, 2001**

Publication Classification

(51) **Int. Cl.⁷ H04J 14/02; H04B 10/00**

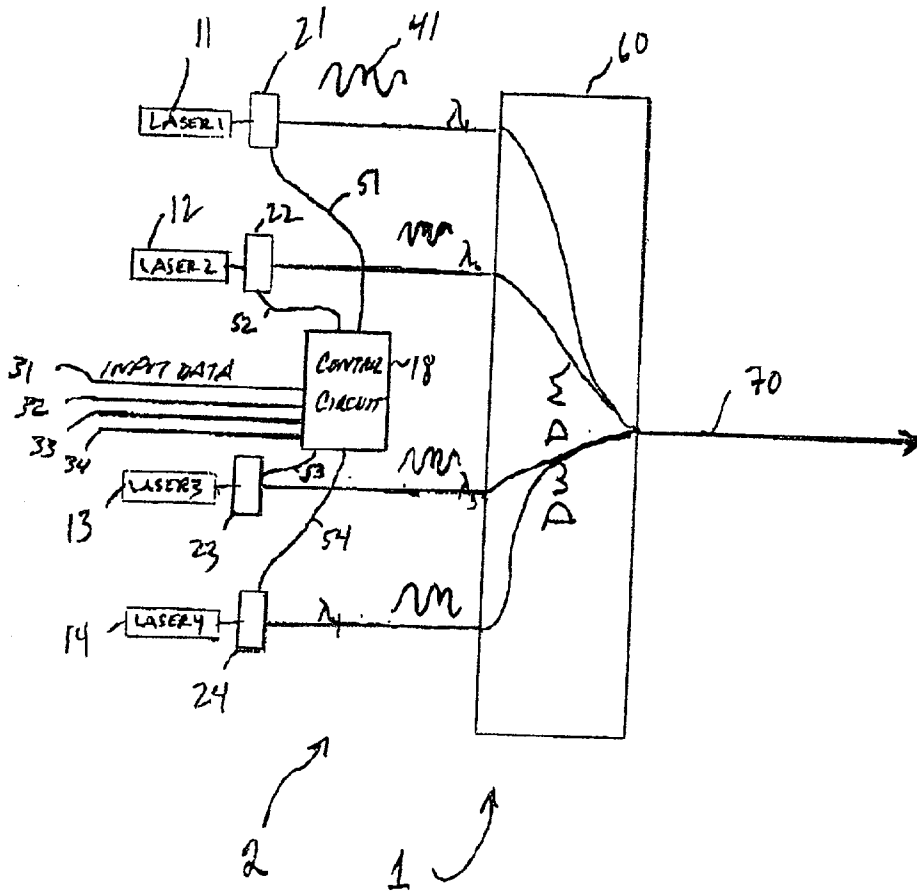

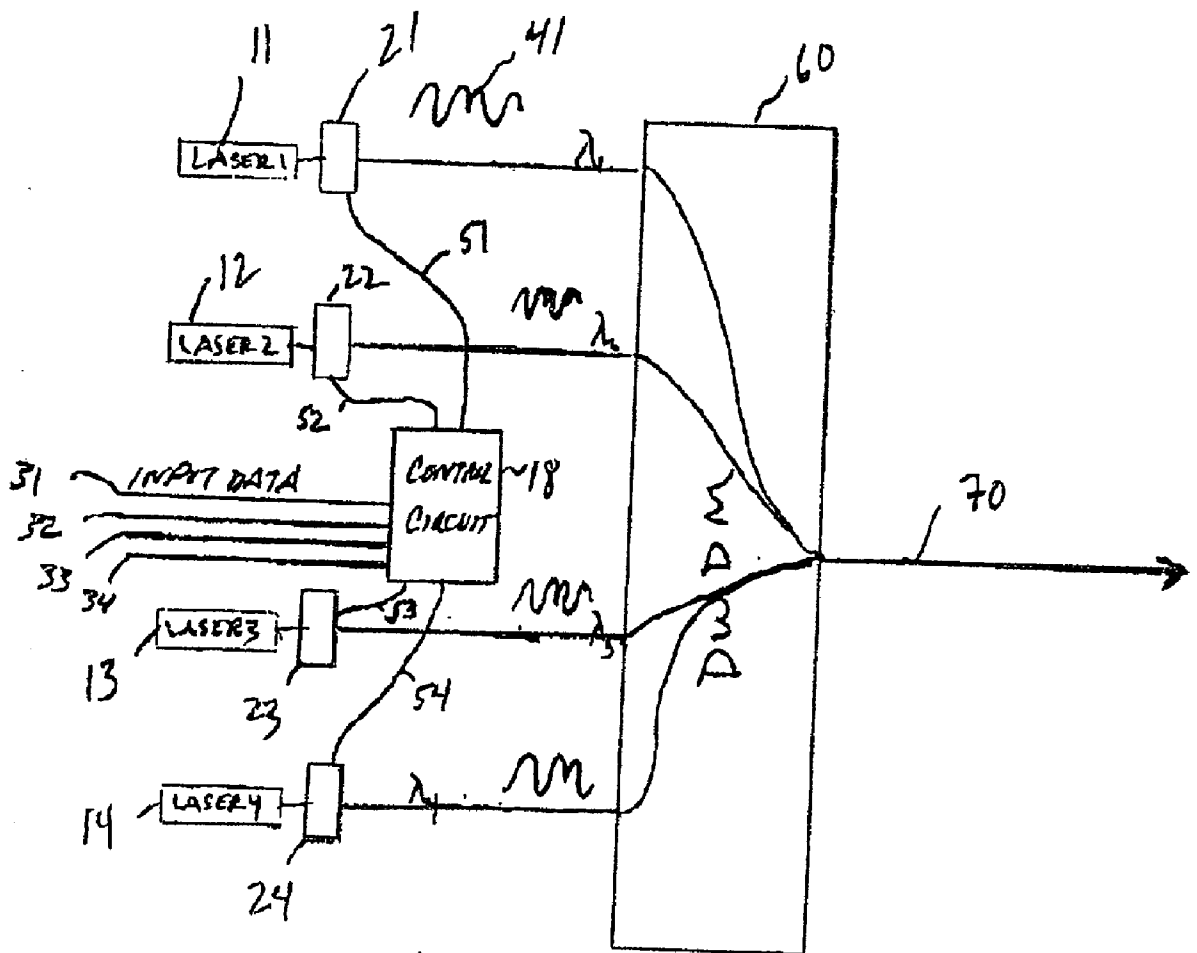
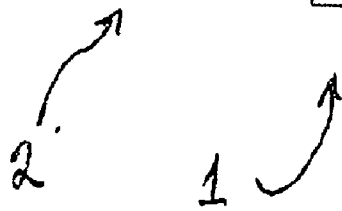

FIG. 1



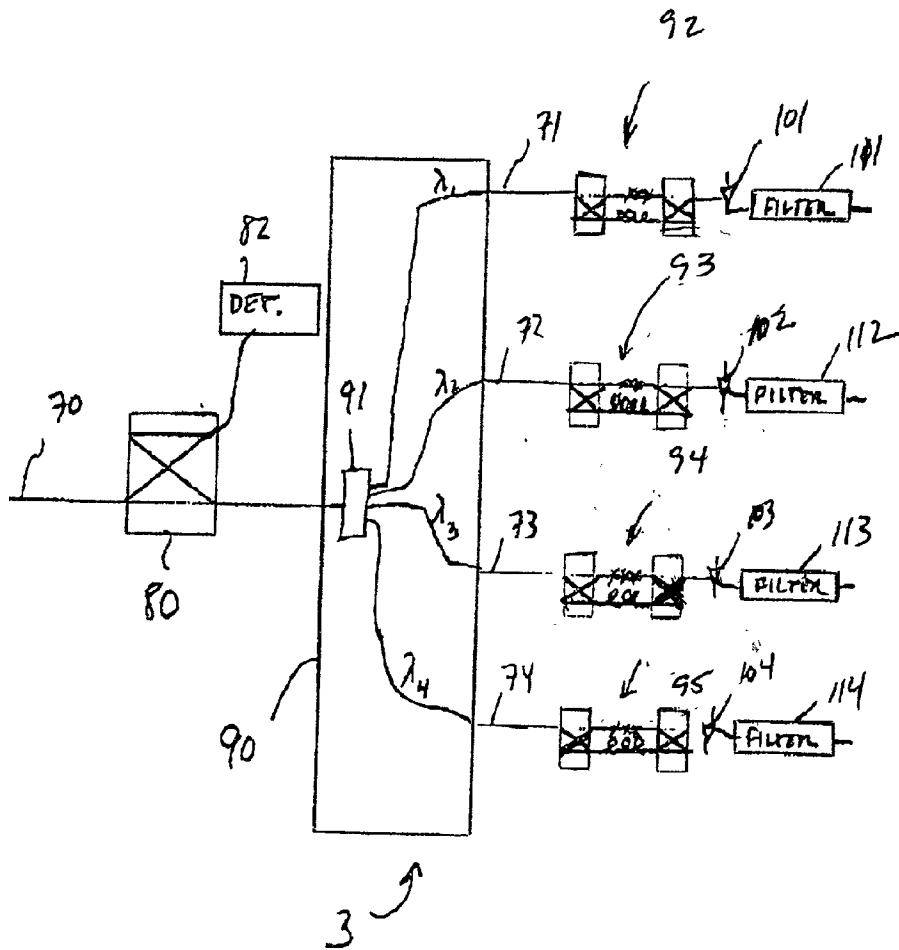

FIG. 2

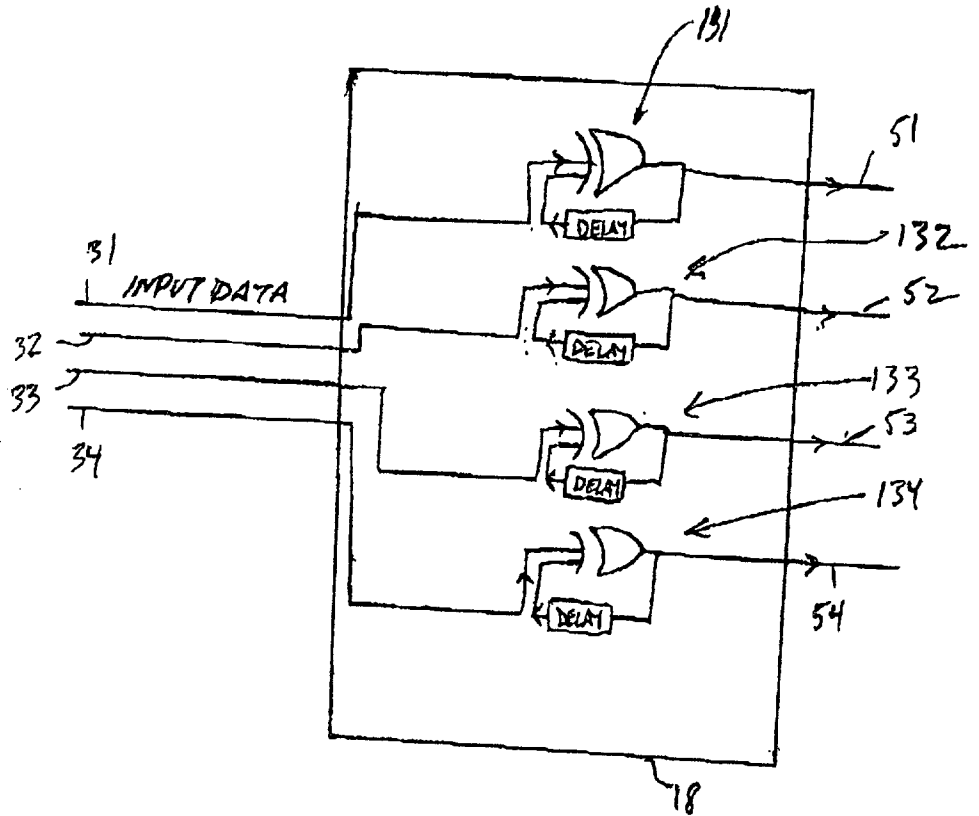

FIG. 3

SECURE WAVE-DIVISION MULTIPLEXING TELECOMMUNICATIONS SYSTEM AND METHOD

BACKGROUND OF THE INVENTION

[0001] 1. Field of the Invention

[0002] The present invention relates generally to telecommunications and more particularly to improving security and data transmission over wave-division multiplexed fiber optic networks.

[0003] 2. Background Information

[0004] In current fiber optic networks, an electronic data stream is fed to a laser amplitude modulator. The laser amplitude modulator typically pulses or alters the laser output to create an amplitude-modulated optical signal representative of the electronic data stream. The laser amplitude modulator and laser thus define a transmitter for transmitting the optical signal over an optical fiber, which is then received by a receiver. The receiver for the amplitude-modulated optical signals of the optical data typically includes a photodiode to convert the optical signals back into the electronic data stream.

[0005] The reading of the amplitude-modulated optical data signals using a photodiode is straightforward: the optical signals either produce an electric output at the photodiode or they do not. As a result, an output electronic data stream of zeros and ones is generated.

[0006] However, optical fiber may be tapped. The optical fibers can be spliced or even merely clamped so as to obtain optical signals from the fiber. It also may be possible to tap fibers without physically touching the optical fiber, for example by reading energy emanating or dissipating along the fiber. Amplitude-modulated optical signals, with their ease of detection from a photodiode, require that only a small amount of energy be tapped and passed through the photodiode in order to be converted into a tapped electronic data stream.

[0007] To confront non-secure optical and non-optical data lines, it has been known to use public key/private key encryption so that the data stream being transmitted is encoded in a format that makes it difficult to decode. Encryption however has several drawbacks, including the need for extra processing steps and time. Moreover, public key/private key encrypted data can be cracked, and the devices and algorithms for doing so are constantly improving.

[0008] U.S. Pat. No. 5,455,698 purports to disclose a secure fiber optic communications system based on the principles of a Sagnac interferometer. A data transmitter is a phase modulator for modulating counter-propagating light beams sent by a receiver round a loop. The receiver includes a light source, a beamsplitter for splitting light from the light source into counter-propagating light beams and for receiving the phase-modulated light beams, and an output detector. U.S. Pat. No. 5,223,967 describes a similar Sagnac-interferometer-based system operating over a single optical fiber.

[0009] The Sagnac-interferometer-based systems described in these patents have the disadvantage that they require the light to travel over a loop, whether back and forth in a single fiber or over a long length looped fiber. As a

result, either the link budget for the single fiber must be doubled, reducing the data carrying capacity for a single fiber, or else a looped fiber with significant and expensive extra length of at least twice that of a single fiber must be laid between the transmitter and the receiver. Moreover, the receiver contains the light source, as opposed to the current installed base where the transmitter has the light source.

[0010] The Sagnac-interferometer-based systems thus are expensive to build and operate, and do not work particularly well with existing systems. Moreover, because a broadband light source is desired for Sagnac-interferometer based systems (see U.S. Pat. No. 5,455,698 at col 1, lines 66 et seq.), these systems do not work well with wavelength division multiplexed (WDM) systems in which data is transmitted over different wavelengths. The U.S. Pat. No. 5,455,698 patent describes splitting a wavelength division multiplexed system with three different wavelengths. However, two of the wavelengths are guard bands strictly used for alarm detection and not for information transmitting. See, e.g., the '698 patent at col. 13, lines 44-55.

[0011] U.S. Pat. No. 6,072,615 purports to describe a method for generating a return-to-zero optical pulses using a phase modulator and optical filter. The RZ-pulse optical signal transmitted over the fiber is easily readable by a detector.

[0012] U.S. Pat. No. 5,606,446 purports to describe an optical telecommunications system employing multiple phase-compensated optical signals. Multiple interferometric systems are combined for the purpose of multiplexing various payloads on the same optical transmission path. The patent attempts to describe a method for providing fiber usage diversity using optical coherence length properties and a complex transmit/receive system. Each transmitter has a splitter, a plurality of fibers and a plurality of phase modulators to create the multiplexed signal, which is then demultiplexed at the receiver. This system is complex and expensive.

[0013] U.S. Pat. No. 5,726,784 purports to describe a WDM optical communications system with remodulators and diverse optical transmitters. An external modulator is used to impart an amplitude-modulated output signal for each wavelength, as described in column 6, lines 14 to 36 of the '784 patent. Optoelectronic detectors can easily read these amplitude-modulated signals. The entirety of U.S. Pat. No. 5,726,784 is hereby incorporated-by-reference herein.

SUMMARY OF THE INVENTION

[0014] An object of the present invention is to provide an improved security WDM transmission system and device. Yet another alternate or additional object of the present invention is to provide a simple yet secure phase-modulated optical data transmission system usable in a WDM system.

[0015] The present invention provides a fiber optic data transmission system comprising a transmitter having a first laser having a first wavelength, a first phase modulator for phase modulating light from the first laser as a function of a first data input stream so as to create a first phase-modulated output data stream, a second laser having a second wavelength different from the first wavelength, and a second phase modulator for phase modulating light from the second laser as a function of a second data input stream

so as to create a second phase-modulated output data stream. A combiner combines the first and second output data streams into a phase-modulated optical signal, which is transmitted over an optical fiber.

[0016] Preferably, a controller controls the first phase modulator as a function of an output of a delayed-feedback exclusive-or gate having the first input data stream as an input, as described in co-owned and co-pending U.S. patent application Ser. No. _____, entitled "Secure Fiber Optics Telecommunications System and Method" and filed on Jan. 17, 2001, the entire disclosure of which is hereby incorporated by reference herein. The controller also preferably controls the second phase modulator as a function of an output of another delayed-feedback exclusive-or gate.

[0017] The present system also includes a receiver receiving the optical signal from the optical fiber. The receiver includes a WDM/DWDM splitter for splitting the optical signal into a first path with the first wavelength and a second path with the second wavelength. A first delayed-arm interferometer receives the first path and a second delayed-arm interferometer receives the second path. The interferometers may be similar to those described in incorporated-by-reference U.S. patent application Ser. No. _____, entitled "Secure Fiber Optics Telecommunications System and Method" and filed on Jan. 17, 2001.

[0018] The first laser preferably is a continuous wave laser, for example a semiconductor laser operating at 1550.92 nm, with the second laser being for example a continuous wave semiconductor laser operating at 1546.12 nm. However, other wavelengths are possible.

[0019] The receiver may include detectors for converting the output optical signals from the interferometers into electronic output data streams. Filters may be provided to reduce any noise at the output signal.

[0020] The system preferably includes a detector for detecting a tap or loss of energy in the optical fiber. Most preferably, the detector is an energy sensor, which may or may not include programmable "trip" levels, which can monitor the amplitude of the light in the fiber. If a tap occurs, it must couple off a significant amount of energy to pass through an interferometer with a low bit error rate, thus making detection of the tap by the detector highly likely. The energy detector preferably is located upstream from the WDM/DWDM splitter.

[0021] Depolarizers preferably are located between the lasers and the respective phase modulators, and in one arm of the interferometers of the receiver.

[0022] The present invention also provides a transmitter comprising a first laser having a first wavelength, a first phase modulator for phase modulating light from the first laser so as to form a phase-modulated first optical data stream, a second laser having a second wavelength different from the first wavelength, a second phase modulator for phase modulating light from the second laser so as to form a phase-modulated second optical data stream, a combiner for combining the phase-modulated first and second optical data streams, and a controller controlling the first and second phase modulators as function of a first input electronic data stream and a second input electronic data stream. The controller preferably includes a first delayed-feedback exclusive-or gate and a second delayed-feedback exclusive-or gate.

[0023] In addition, the present invention also provides a receiver comprising an optical splitter for splitting light into a first wavelength and a second wavelength different from the first wavelength, and a first interferometer receiving light at the first wavelength and a second interferometer receiving light at the second wavelength.

[0024] The optical WDM/DWDM splitter preferably includes a Bragg grating.

[0025] A method for transmitting secure data is also provided comprising the steps of: transmitting light from a first laser at a data transmitter; phase modulating light from the first laser at the data transmitter as a function of a first electronic data input stream; transmitting light from a second laser having a wavelength different from the first laser; phase modulating light from the second laser at the data transmitter as a function of a second electronic data input stream; and combining light from the first and second lasers so as to create a combined output signal with phase-modulated data.

[0026] Preferably, the phase modulated data is a function of outputs of delayed-feedback exclusive-or gates. Preferably, all of the light from the first and second lasers is phase-modulated.

[0027] The method further may include receiving the phase-modulated combined optical signal in a receiver, and splitting the combined output signal into a first and second path as a function of wavelength. The first and second paths are then each passed through an interferometer.

[0028] The method preferably includes monitoring a fiber for intrusion. The monitoring preferably includes monitoring an energy level in the fiber with programmable trip levels.

[0029] While the invention has been described with two different wavelength lasers, more lasers are of course possible.

BRIEF DESCRIPTION OF THE DRAWINGS

[0030] A preferred embodiment of the present invention is described below by reference to the following drawings, in which:

[0031] FIG. 1 shows a transmitter of the present invention;

[0032] FIG. 2 shows a receiver of the present invention; and

[0033] FIG. 3 shows details of the control system of FIG. 1.

DETAILED DESCRIPTION

[0034] FIG. 1 shows a preferred embodiment of a secure telecommunications system 1 with wave division multiplexing according to the present invention. The system 1 includes a transmitter 2 with continuous wave coherent lasers 11, 12, 13 and 14, each for example a semiconductor laser emitting a narrow band of light at 1557 nm, 1554 nm, 1551 nm and 1548 nm, respectively. Other wavelengths however are possible. Light emitted from lasers 11, 12, 13, 14 is depolarized and then passes through phase modulators 21, 22, 23, 24, respectively, each for example a Mach-Zender phase modulator. An electronic controller 18 con-

trols phase modulators **21, 22, 23, 24** as a function of four input electronic data streams **31, 32, 33, 34**, respectively. Controller **18** is also programmable to control the optical power output of light emitted by lasers **11, 12, 13, 14**. Preferably, the power output of the lasers is set as low as possible for a given optical span, while maintaining a low bit error rate. This reduces the light available for any tap.

[**0035**] Depending on the binary output **51** of controller **18**, phase modulator **21** either imparts a first phase shift to the light (for example, zero) or a second phase shift different from the first phase shift (for example, 180 degrees) on the light passing through phase modulator **21**, thus creating a phase-modulated optical signal **41**, which represents a stream of binary bits. The first phase shift for example represents a binary zero and the second phase shift a binary one. Likewise, phase modulators **22, 23, 24**, as a function of outputs **52, 53, 54** of controller **18** respectively, impart a first phase shift or second phase shift on light from lasers **12, 13, 14**, respectively. Thus independent data streams **41, 42, 43, 44** are created.

[**0036**] FIG. 3 shows a representation of the control circuit of controller **18**. Each input electronic data stream **31, 32, 33, 34** is fed through a delayed-feedback exclusive-or gate **131, 132, 133, 134**, respectively. Each feedback delay of each gate **131, 132, 133, 134** may equal, for example, a number of bits. The feedback delays may be the same or, preferably, differ among the gates **131, 132, 133, 134**. The binary output streams **51, 52, 53, 54** are used to phase modulate the light from lasers **11, 12, 13, 14**, respectively, to create the phase-modulated optical data streams **41, 42, 43, 44**.

[**0037**] Optical data streams **41, 42, 43, 44** are combined in a combiner **60** which combines the light at the different wavelengths and sends it over a fiber **70**.

[**0038**] Light from fiber **70** is received in a receiver **3** according to the present invention. A splitter **80** splits off a portion of the light, directing part of the optical energy to the light monitoring detector **82** and passing the remaining light to a wave division splitter **90** preferably having a Bragg grating **91**.

[**0039**] A detector **82**, for example a light energy detector, monitors the light energy in the fiber **70** via the light energy coupled to the detector by splitter **80**, the light energy being a function of the amplitude. If the amplitude drops, most likely from a tap, the detector alerts the receiver and can, for example, sound an alarm or alert network maintenance personnel. Additionally, since the receiver **3** is generally part of a component box, which also includes a transmitter, the component box transmitter can send a signal back to the component box containing transmitter **2** so as to instruct transmitter **2** to stop sending data, or to send data over a standby fiber. Detector **82**, while preferably part of receiver **3**, also could be located separately from receiver **3**, for example where fiber **70** enters a building or other secure environment.

[**0040**] WDM splitter **90** splits the light into the four wavelengths originally sent by lasers **11, 12, 13** and **14** to paths **71, 72, 73, 74**. Each path **71, 72, 73, 74** enters a delayed-arm interferometer **92, 93, 94, 95**. The delay loop of each interferometer **92, 93, 94, 95** corresponds to the electronic feedback delay in each of the circuits **131, 132, 133, 133**, respectively.

[**0041**] The phase-modulated data as it passes through the respective interferometer **92, 93, 94, 95** either constructively interferes or destructively interferes so as to create signals read by detectors **101, 102, 103, 104**, the signals being representative of input data **31, 32, 33, 34**, respectively. This process is described in more detail in incorporated-by-reference U.S. patent application No. _____, entitled "Secure Fiber Optics Telecommunications System and Method" and filed on Jan. 17, 2001.

[**0042**] Filters **111, 112, 113** and **114** are provided to compensate for any slight mismatch between the optical delay in the interferometer and the electronic delay, and for other noise.

[**0043**] System **1** provides a secure method for transmitting multiple streams of data over a single optical fiber, which is difficult to decode if tapped, and also permits excellent detection of the existence of a tap.

What is claimed is:

1. A fiber optic data transmission system comprising:
 - a fiber optic data transmission system comprising:
 - an optical fiber; and
 - a data transmitter having a first laser having a first wavelength, a first phase modulator for phase modulating light from the first laser as a function of a first data input stream so as to create a first phase-modulated output data stream, a second laser having a second wavelength different from the first wavelength, and a second phase modulator for phase modulating light from the second laser as a function of a second data input stream so as to create a second phase-modulated output data stream, the transmitter further including a combiner combining the first and second output data streams into a phase-modulated optical signal for transmission over the optical fiber.
 2. The system as recited in claim 1 further comprising a controller controlling the first phase modulator as a function of an output of a delayed-feedback exclusive-or gate having the first input data stream as an input.
 3. The system as recited in claim 2 wherein the controller controls the second phase modulator as a function of another output of another delayed-feedback exclusive-or gate.
 4. The system as recited in claim 1 further comprising a receiver receiving the phase-modulated optical signal from the optical fiber, the receiver including a splitter for splitting the optical signal into a first path with the first wavelength and a second path with the second wavelength.
 5. The system as recited in claim 4 wherein the receiver includes a first interferometer receiving the first path and a second interferometer receiving the second path.
 6. The system as recited in claim 1 further comprising a detector for detecting a tap or loss of energy in the optical fiber.
 7. A transmitter comprising:
 - a first laser having a first wavelength;
 - a first phase modulator for phase modulating light from the first laser so as to form a phase-modulated first optical data stream;
 - a second laser having a second wavelength different from the first wavelength;

- a second phase modulator for phase modulating light from the second laser so as to form a phase-modulated second optical data stream,
 - a combiner for combining the phase-modulated first and second optical data streams, and
 - a controller controlling the first and second phase modulators as function of a first input electronic data stream and a second input electronic data stream.
8. The transmitter as recited in claim 7 wherein the controller includes a first delayed-feedback exclusive-or gate and a second delayed-feedback exclusive-or gate.
9. The transmitter as recited in claim 7 further comprising a plurality of further lasers having different wavelengths.
10. A receiver comprising:
- an optical splitter for splitting light into a first wavelength and a second wavelength different from the first wavelength, and a first interferometer receiving light at the first wavelength and a second interferometer receiving light at the second wavelength.
11. The receiver as recited in claim 10 wherein the optical splitter includes a Bragg grating.
12. The receiver as recited in claim 10 further comprising a detector for detecting a tap or loss of energy in the optical fiber.
13. The receiver as recited in claim 10 further comprising a plurality of further interferometers.
14. A method for transmitting secure data is also provided comprising the steps of:
- transmitting light from a first laser at a data transmitter;

- phase modulating light from the first laser at the data transmitter as a function of a first electronic data input stream so as to create a first output data stream, a first binary bit being represented by a first phase and a second binary bit being presented by a second phase different from the first phase;
 - transmitting light from a second laser having a wavelength different from the first laser;
 - phase modulating light from the second laser at the data transmitter as a function of a second electronic data input stream so as to create a second output data stream; and
 - combining the first and second output data streams.
15. The method as recited in claim 14 wherein the phase modulated data is a function of outputs of delayed-feedback exclusive-or gates.
16. The method as recited in claim 14 wherein all of the light from the first and second lasers is phase-modulated.
17. The method as recited in claim 14 further including receiving the phase-modulated combined optical signal in a receiver, and splitting the combined output signal into a first and second path as a function of wavelength.
18. The method as recited in claim 17 further comprising passing each of the first and second paths through an interferometer.
19. The method as recited in claim 14 further including monitoring a fiber for intrusion.

* * * * *