

(12) UK Patent Application (19) GB (11) 2577436 (13) A

(43) Date of Reproduction by UK Office 25.03.2020

(21) Application No: 1918203.9  
(22) Date of Filing: 20.06.2017  
Date Lodged: 11.12.2019  
(30) Priority Data:  
(31) 15628418 (32) 20.06.2017 (33) US  
(86) International Application Data:  
PCT/US2018/037877 En 15.06.2018  
(87) International Publication Data:  
WO2018/236690 En 27.12.2018

(51) INT CL:  
F16K 5/04 (2006.01) F16K 3/08 (2006.01)  
F16K 3/26 (2006.01) F16K 5/10 (2006.01)  
F16K 11/085 (2006.01) F16K 47/04 (2006.01)

(56) Documents Cited:  
US 5417083 A US 5074522 A  
US 4665946 A US 20170015680 A1  
US 20140332103 A US 20110067770 A1  
US 20030015245 A1 US 20020124895 A1

(58) Field of Search:  
INT CL F16K  
Other: NOT ADVISED

(71) Applicant(s):  
Control Components, Inc.  
(Incorporated in USA - Delaware)  
22591 Avenida Empresa, Rancho Santa Margarita,  
California 92688, United States of America

(72) Inventor(s):  
Timo Kubota  
Matthew Wilson

(74) Agent and/or Address for Service:  
CSY Herts  
Helios Court, 1 Bishop Square, HATFIELD,  
Hertfordshire, AL10 9NE, United Kingdom

(54) Title of the Invention: Multi-stage, multi-path rotary disc valve  
Abstract Title: Multi-stage, multi-path rotary disc valve

(57) A control valve includes a valve body having a main valve passageway. A flow control assembly is positioned in the main valve passageway and includes a first control element, and a second control element rotatable relative to the first control element between a closed position, a first position, and a second position. In the closed position, the first and second control elements form a plug which prevents fluid flow through the main valve passageway. In the first position, the first and second control elements collectively define a first control passageway therethrough, and in the second position, the first and second control elements collectively define the first control passageway and a second control passageway therethrough.

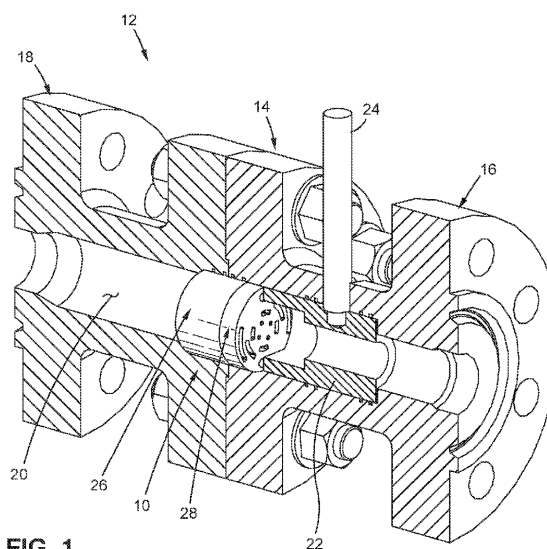

FIG. 1

GB 2577436 A