



US00D382125S

United States Patent [19]
Chuang

[11] **Patent Number:** **Des. 382,125**
[45] **Date of Patent:** ****Aug. 12, 1997**

[54] **FOOTBOARD**
[76] **Inventor:** **Kuo-Hsien Chuang**, 5F, No. 22,
Hsin-Ming Rd., Nei Hu, Taipei, Taiwan
[**] **Term:** **14 Years**
[21] **Appl. No.:** **49,693**
[22] **Filed:** **Jan. 29, 1996**
[51] **LOC (6) Cl.** **06-01**
[52] **U.S. Cl.** **D6/353; D6/349**
[58] **Field of Search** **D6/349, 352, 353,**
D6/355; D21/191; 297/461, 462, 423.39,
423.41, 423.43, 423.44, 423.45, 423.46

5,348,377 9/1994 Grosch 297/423.45

Primary Examiner—Janice E. Seeger
Attorney, Agent, or Firm—Beveridge, DeGrandi, Weilacher
& Young LLP

[57] **CLAIM**

The ornamental design for footboard, as shown and described.

DESCRIPTION

FIG. 1 is the perspective view of a “footboard” showing my new design;
FIG. 2 is the front elevational view thereof;
FIG. 3 is the rear elevational view thereof;
FIG. 4 is the left side elevational view thereof;
FIG. 5 is the right side elevational view thereof;
FIG. 6 is the top plan view thereof; and,
FIG. 7 is the bottom plan view thereof.

[56] **References Cited**

U.S. PATENT DOCUMENTS

D. 244,893 7/1977 Diehl D6/353
D. 343,960 2/1994 Leduc D6/349

1 Claim, 7 Drawing Sheets

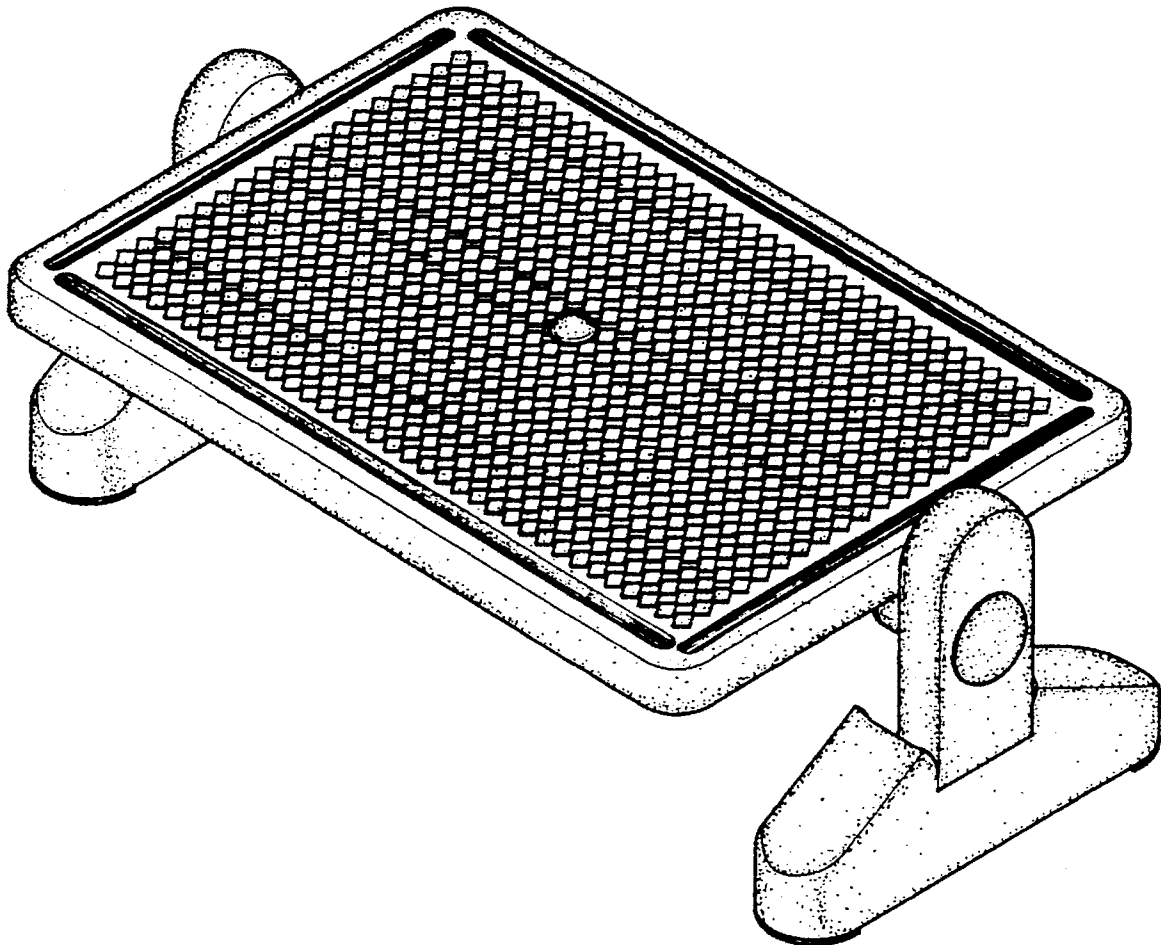

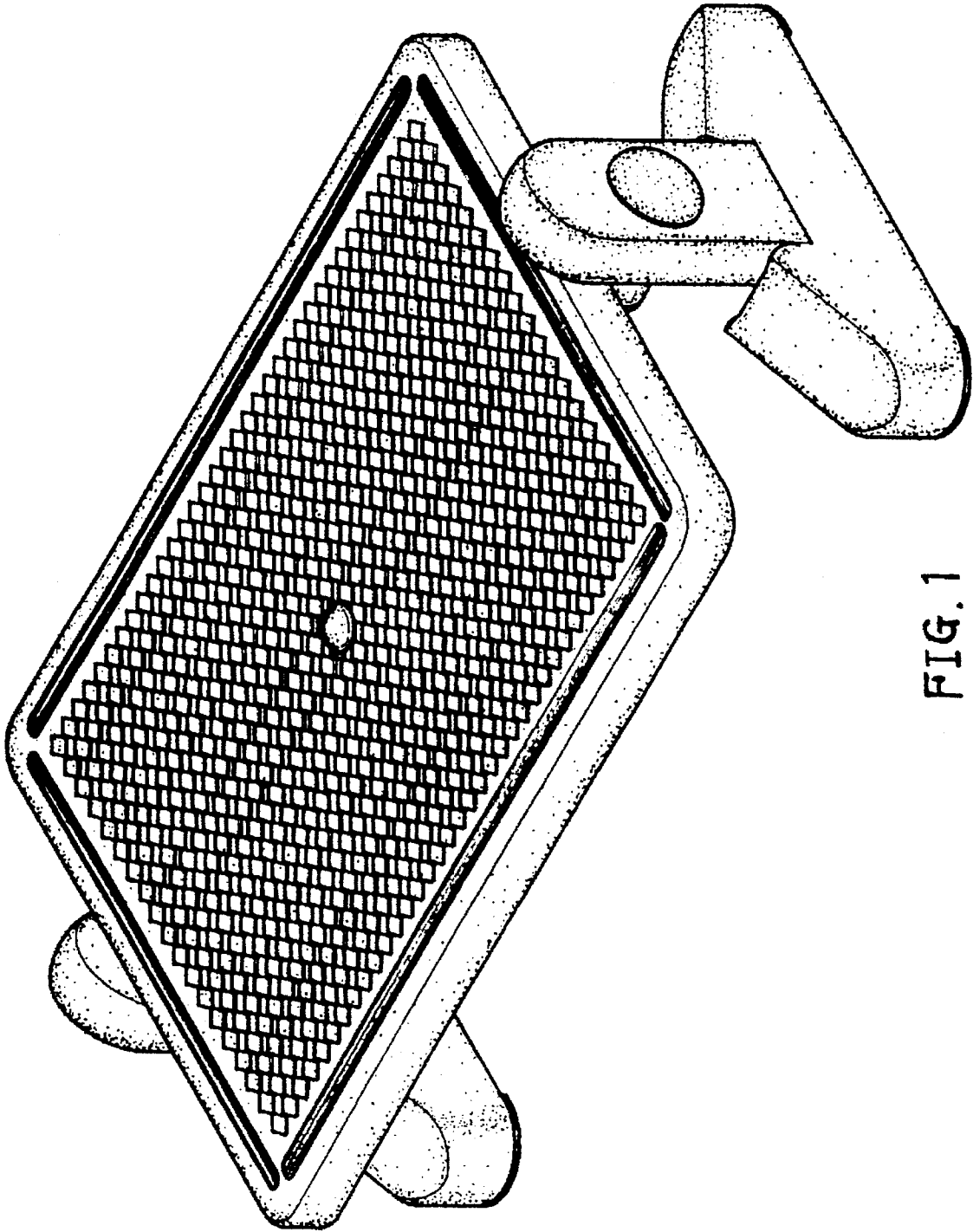

FIG. 1

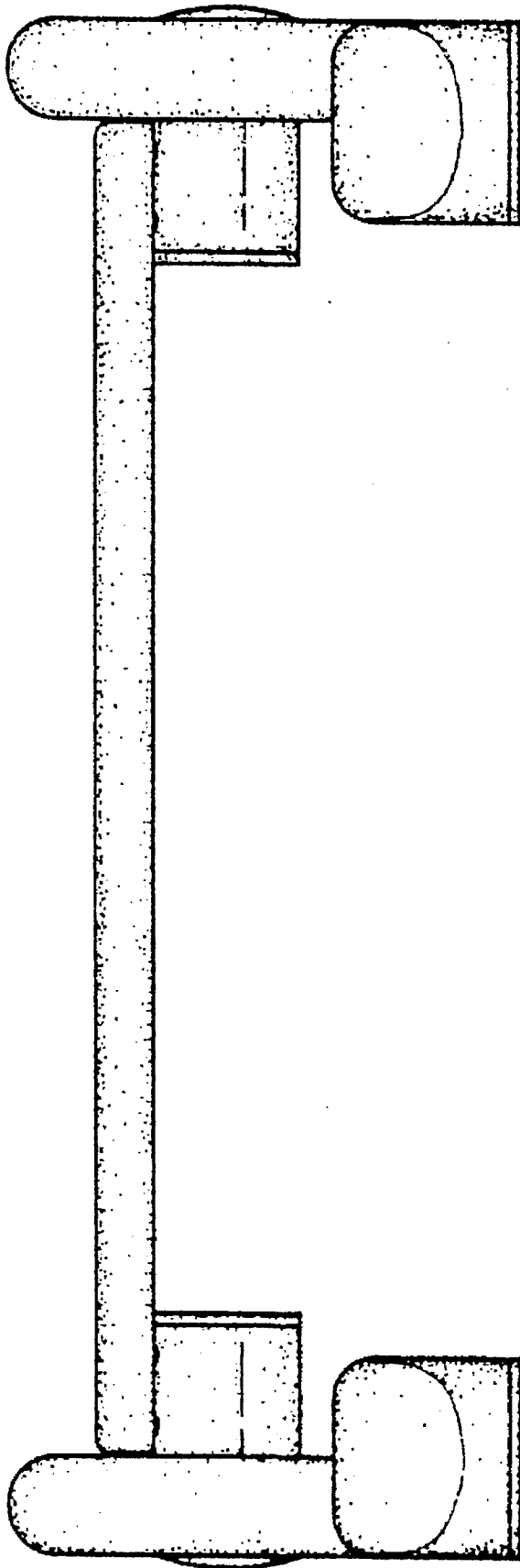

FIG. 2

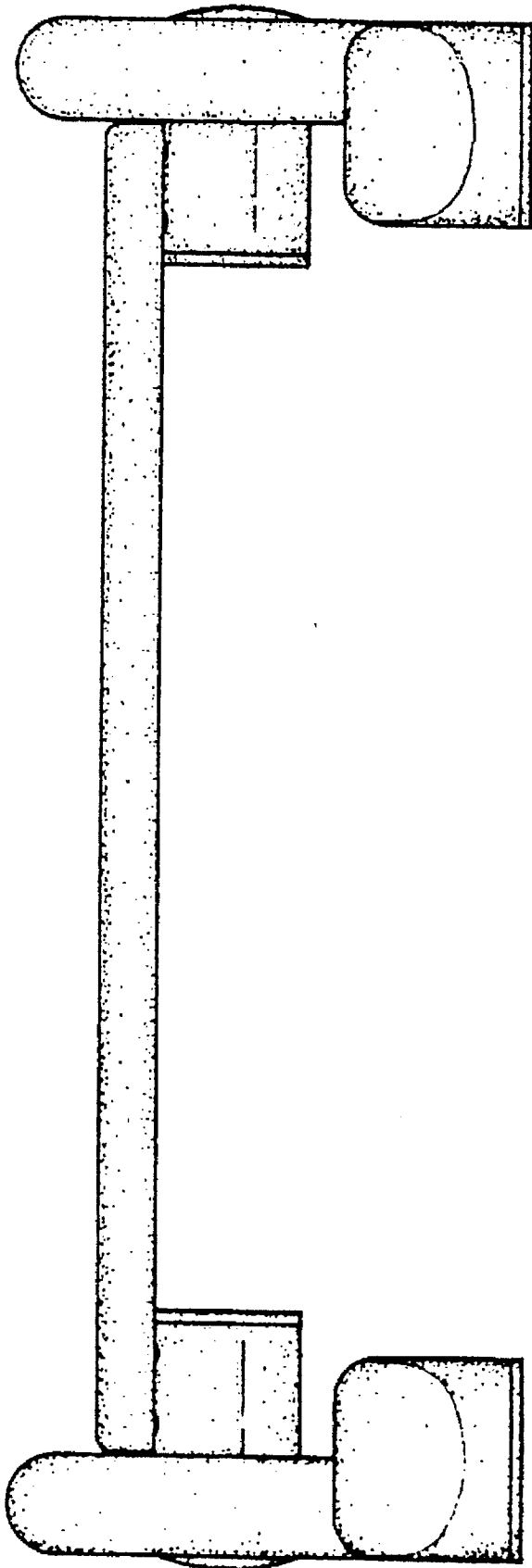

FIG. 3

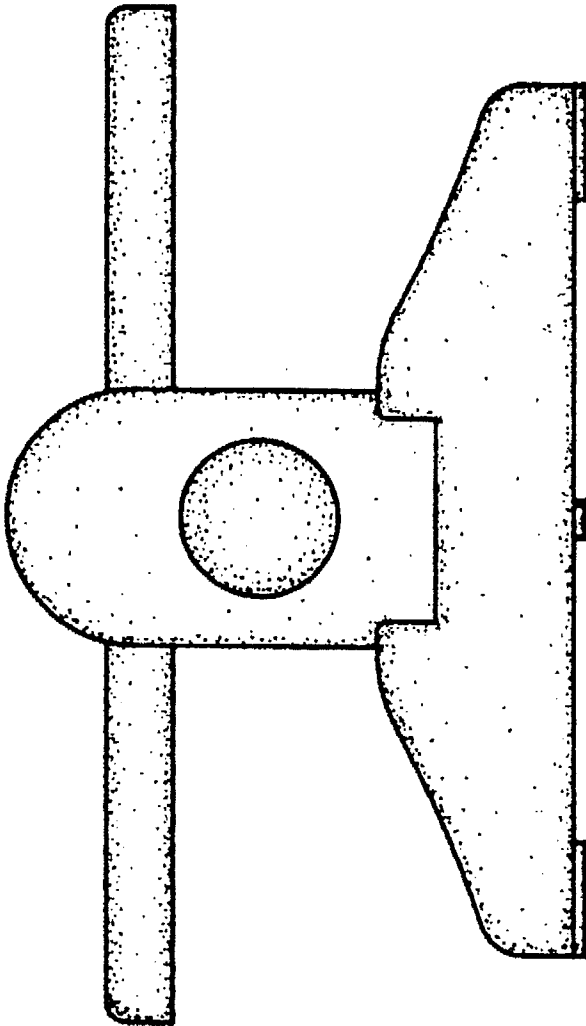

FIG. 4

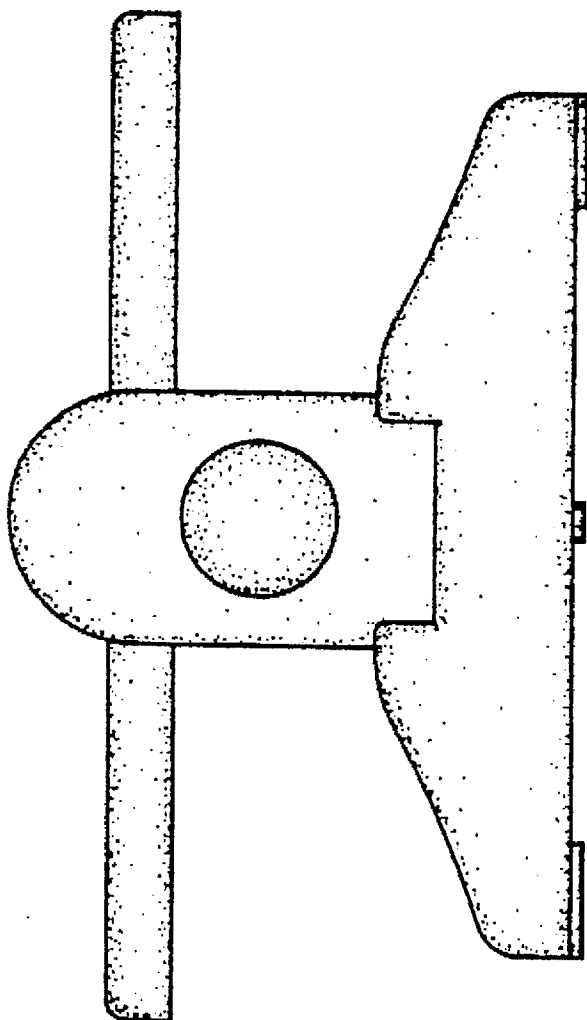

FIG. 5

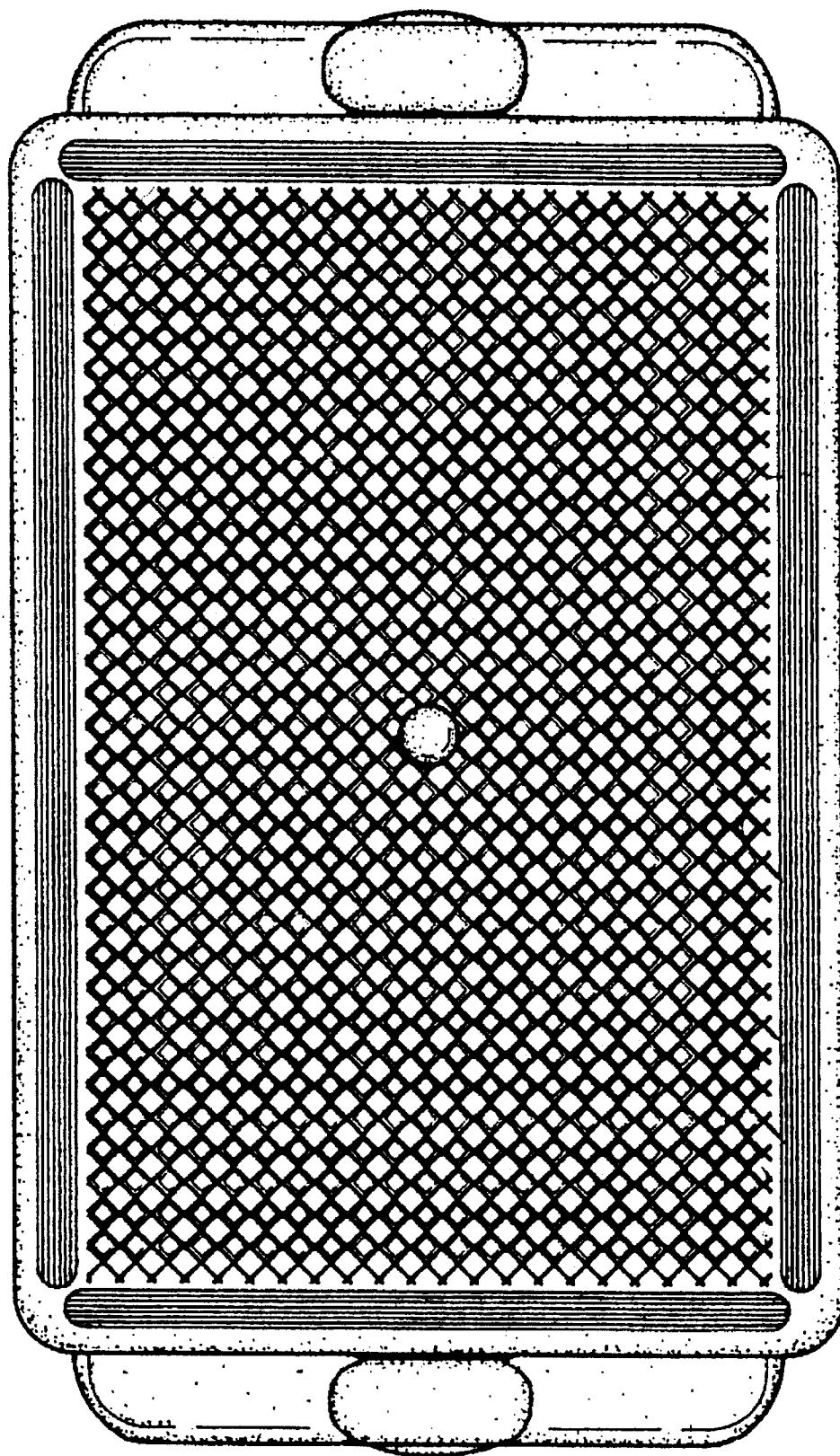

FIG. 6

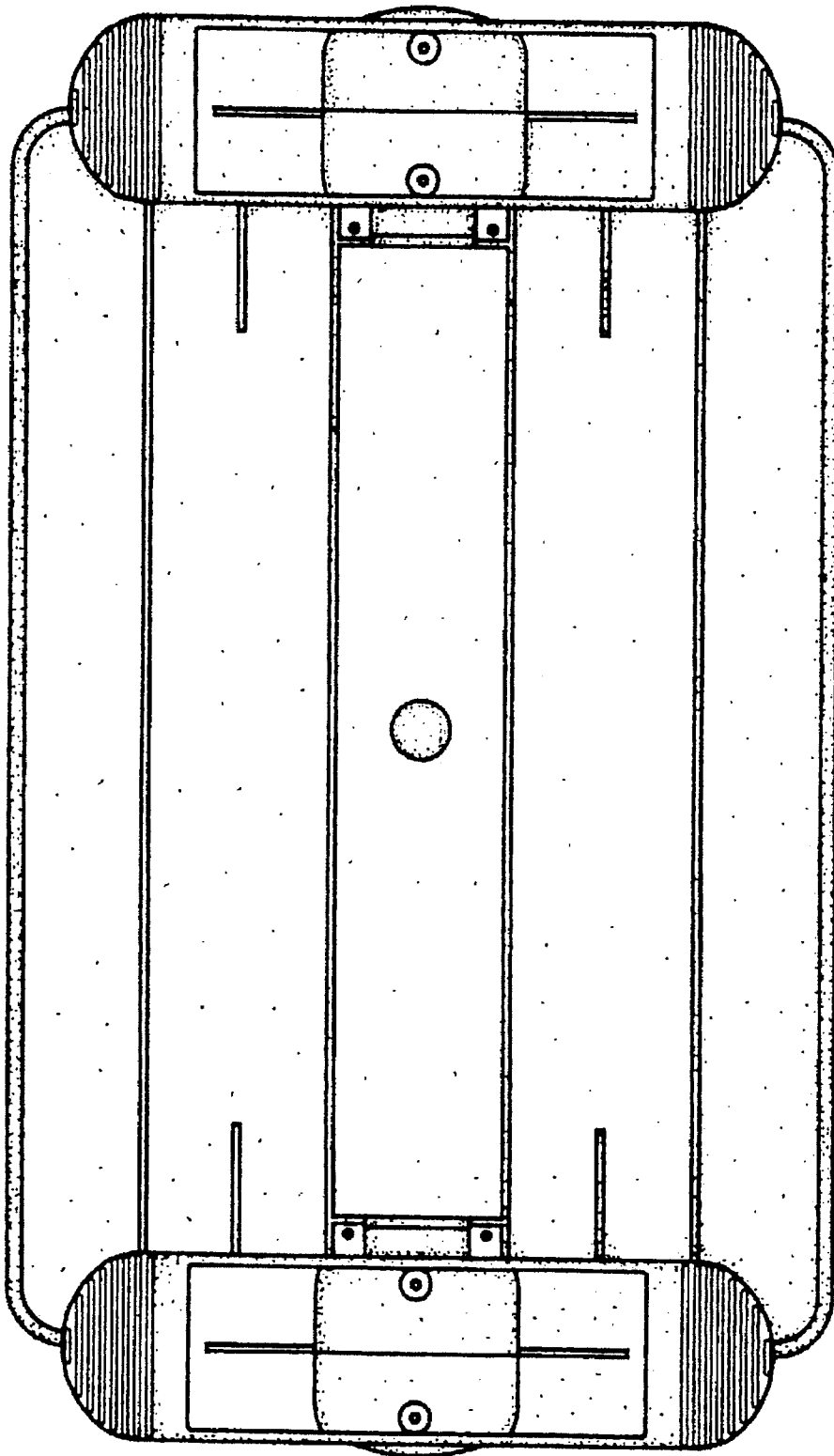

FIG. 7