



US009642627B2

(12) **United States Patent**
Zammataro

(10) **Patent No.:** **US 9,642,627 B2**

(45) **Date of Patent:** **May 9, 2017**

(54) **SELF-CENTERING CLIP AND JAW**

(71) Applicant: **Covidien LP**, Mansfield, MA (US)

(72) Inventor: **Tom Zammataro**, Hamden, CT (US)

(73) Assignee: **Covidien LP**, Mansfield, MA (US)

(*) Notice: Subject to any disclaimer, the term of this patent is extended or adjusted under 35 U.S.C. 154(b) by 0 days.

(21) Appl. No.: **14/665,623**

(22) Filed: **Mar. 23, 2015**

(65) **Prior Publication Data**

US 2015/0190139 A1 Jul. 9, 2015

Related U.S. Application Data

(62) Division of application No. 13/196,109, filed on Aug. 2, 2011, now Pat. No. 9,011,464.
(Continued)

(51) **Int. Cl.**
A61B 17/10 (2006.01)
A61B 17/128 (2006.01)
(Continued)

(52) **U.S. Cl.**
CPC **A61B 17/1285** (2013.01); **A61B 17/122** (2013.01); **A61B 17/128** (2013.01);
(Continued)

(58) **Field of Classification Search**
CPC . A61B 17/1285; A61B 17/122; A61B 17/128;
A61B 17/12; A61B 2017/12004; A61B
2017/0488
(Continued)

(56) **References Cited**

U.S. PATENT DOCUMENTS

3,120,230 A 2/1964 Skold
3,270,745 A * 9/1966 Wood 606/158
(Continued)

FOREIGN PATENT DOCUMENTS

AU 2010200641 A1 10/2010
CN 1994236 A 7/2007
(Continued)

OTHER PUBLICATIONS

The extended European Search Report corresponding to European Application No. EP 07 25 3905.9, completed Jan. 29, 2008; mailed Feb. 7, 2008; (7 Pages).

(Continued)

Primary Examiner — Jing Ou

(57) **ABSTRACT**

An apparatus for applying surgical clips to tissue includes a handle assembly having a trigger and a shaft extending therefrom. The shaft includes at least one surgical clip therein. Each clip includes a pair of legs connected by a crossbar. Each of the pair of legs has an inwardly and an outwardly facing surface, the outwardly facing surface having a raised profile protruding therefrom and extending longitudinally therealong. A jaw assembly is disposed at a distal end of the shaft and includes first and second opposed jaws moveable between a spaced apart and an approximated position. Each jaw defines a recess extending longitudinally along opposing inner surfaces thereof. Each recess defines a longitudinally extending groove having a profile substantially complementary to the raised profile of the legs of the clips. The legs of each clip are positionable at least partially within respective grooves of the recesses of the jaws.

18 Claims, 6 Drawing Sheets

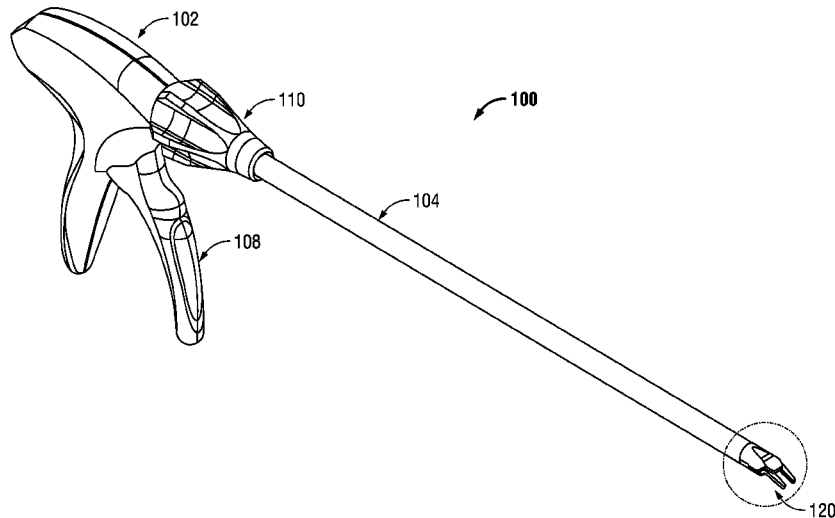

Related U.S. Application Data

- (60) Provisional application No. 61/409,131, filed on Nov. 2, 2010.
- (51) **Int. Cl.**
A61B 17/122 (2006.01)
A61B 17/12 (2006.01)
A61B 17/04 (2006.01)
- (52) **U.S. Cl.**
 CPC *A61B 17/10* (2013.01); *A61B 17/12* (2013.01); *A61B 2017/0488* (2013.01); *A61B 2017/12004* (2013.01)
- (58) **Field of Classification Search**
 USPC 606/139, 142, 143, 157, 158
 See application file for complete search history.

4,696,396	A	9/1987	Samuels
4,702,247	A	10/1987	Blake, III et al.
4,706,668	A	11/1987	Backer
4,712,549	A	12/1987	Peters et al.
4,733,666	A	3/1988	Mercer, Jr.
4,759,364	A	7/1988	Boebel
4,765,335	A	8/1988	Schmidt et al.
4,777,949	A	10/1988	Perlin
4,796,625	A	1/1989	Kees, Jr.
4,799,481	A	1/1989	Transue et al.
4,815,466	A	3/1989	Perlin
4,821,721	A	4/1989	Chin et al.
4,822,348	A	4/1989	Casey
4,834,096	A	5/1989	Oh et al.
4,850,355	A	7/1989	Brooks et al.
4,854,317	A	8/1989	Braun
4,856,517	A	8/1989	Collins et al.
4,929,239	A	5/1990	Braun
4,931,058	A	6/1990	Cooper
4,934,364	A	6/1990	Green
4,957,500	A	9/1990	Liang et al.
4,966,603	A	10/1990	Focelle et al.
4,967,949	A	11/1990	Sandhaus
4,979,950	A	12/1990	Transue et al. 606/158
4,983,176	A	1/1991	Cushman et al.
4,988,355	A	1/1991	Leveen et al.
5,002,552	A	3/1991	Casey
5,026,379	A	6/1991	Yoon
5,030,224	A	7/1991	Wright et al.
5,030,226	A	7/1991	Green et al.
5,032,127	A	7/1991	Frazee et al.
5,035,692	A	7/1991	Lyon et al.
5,047,038	A	9/1991	Peters et al.
5,049,152	A	9/1991	Simon et al.
5,049,153	A	9/1991	Nakao et al.
5,053,045	A	10/1991	Schmidt et al.
5,059,202	A	10/1991	Liang et al.
5,062,846	A	11/1991	Oh et al.
5,078,731	A	1/1992	Hayhurst
5,084,057	A	1/1992	Green et al.
5,100,416	A	3/1992	Oh et al.
5,100,420	A	3/1992	Green et al.
5,104,394	A	4/1992	Knoepfler
5,104,395	A	4/1992	Thornton et al.
5,112,343	A	5/1992	Thornton
5,122,150	A	6/1992	Puig
5,127,915	A	7/1992	Mattson
5,129,885	A	7/1992	Green et al.
5,156,608	A	10/1992	Troidl et al.
5,160,339	A	11/1992	Chen et al.
5,163,945	A	11/1992	Ortiz et al.
5,171,247	A	12/1992	Hughett et al.
5,171,249	A	12/1992	Stefanchik et al.
5,171,250	A	12/1992	Yoon
5,171,251	A	12/1992	Bregen et al.
5,171,252	A	12/1992	Friedland
5,171,253	A	12/1992	Klieman
5,192,288	A	3/1993	Thompson et al.
5,197,970	A	3/1993	Green et al.
5,199,566	A	4/1993	Ortiz et al.
5,201,746	A	4/1993	Shichman
5,201,900	A	4/1993	Nardella
5,207,691	A	5/1993	Nardella
5,207,692	A	5/1993	Kraus et al.
5,217,473	A	6/1993	Yoon
5,219,353	A	6/1993	Garvey, III et al.
5,246,450	A	9/1993	Thornton et al.
5,269,792	A	12/1993	Kovac et al.
5,281,228	A	1/1994	Wolfson
5,282,807	A	2/1994	Knoepfler
5,282,808	A	2/1994	Kovac et al.
5,282,832	A	2/1994	Toso et al.
5,289,963	A	3/1994	McGarry et al.
5,290,299	A	3/1994	Fain et al.
5,300,081	A	4/1994	Young et al.
5,304,183	A	4/1994	Gourlay et al.
5,306,280	A	4/1994	Bregen et al.
5,306,283	A	4/1994	Connors
5,312,426	A	5/1994	Segawa et al.

(56) **References Cited**

U.S. PATENT DOCUMENTS

3,363,628	A	1/1968	Wood
3,631,707	A	1/1972	Miller
3,638,847	A	2/1972	Noiles et al.
3,735,762	A	5/1973	Bryan et al.
3,867,944	A	2/1975	Samuels
4,242,902	A	1/1981	Green
4,296,751	A	10/1981	Blake, III et al.
4,372,316	A	2/1983	Blake, III et al.
4,408,603	A	10/1983	Blake, III et al.
4,412,539	A	11/1983	Jarvik
4,478,220	A	10/1984	Di Giovanni et al.
4,480,640	A	11/1984	Becht
4,480,641	A	11/1984	Failla et al.
4,487,204	A	12/1984	Hrouda
4,487,205	A	12/1984	Di Giovanni et al.
4,491,133	A	1/1985	Menges et al.
4,492,232	A	1/1985	Green
4,498,476	A	2/1985	Cerwin et al.
4,500,024	A	2/1985	DiGiovanni et al.
4,509,518	A	4/1985	McGarry et al.
4,512,345	A	4/1985	Green
4,522,207	A	6/1985	Klieman et al.
4,527,562	A	7/1985	Mericle 606/158
4,532,925	A	8/1985	Blake, III
4,534,351	A	8/1985	Rothfuss et al.
4,545,377	A	10/1985	Cerwin et al.
4,549,544	A	10/1985	Favaron
4,550,729	A	11/1985	Cerwin et al. 606/158
4,556,058	A	12/1985	Green
4,557,263	A	12/1985	Green
4,562,839	A	1/1986	Blake, III et al.
4,572,183	A	2/1986	Juska
4,576,165	A	3/1986	Green et al.
4,576,166	A	3/1986	Montgomery et al.
4,579,118	A	4/1986	Failla 606/158
4,590,937	A	5/1986	Deniega
4,598,711	A	7/1986	Deniega
4,602,631	A	7/1986	Funatsu
4,611,595	A	9/1986	Klieman et al.
4,612,932	A	9/1986	Caspar et al.
4,616,650	A	10/1986	Green et al.
4,616,651	A	10/1986	Golden
4,624,254	A	11/1986	McGarry et al.
4,637,395	A	1/1987	Caspar et al.
4,638,804	A	1/1987	Jewusiak 606/158
4,646,740	A	3/1987	Peters et al.
4,647,504	A	3/1987	Kimimura et al.
4,658,822	A	4/1987	Kees, Jr.
4,660,558	A	4/1987	Kees, Jr.
4,662,373	A	5/1987	Montgomery et al.
4,662,374	A	5/1987	Blake, III
4,671,278	A	6/1987	Chin
4,671,282	A	6/1987	Tretbar
4,674,504	A	6/1987	Klieman et al.
4,681,107	A	7/1987	Kees, Jr.

(56)

References Cited

U.S. PATENT DOCUMENTS

5,330,442	A	7/1994	Green et al.	5,683,405	A	11/1997	Yacoubian et al.
5,330,487	A	7/1994	Thornton et al.	5,695,502	A	12/1997	Pier et al.
5,340,360	A	8/1994	Stefanchik	5,695,505	A	12/1997	Yoon
5,342,373	A	8/1994	Stefanchik et al.	5,697,938	A	12/1997	Jensen et al.
5,354,304	A	10/1994	Allen et al.	5,700,270	A	12/1997	Peysner et al.
5,354,306	A	10/1994	Garvey, III et al.	5,700,271	A	12/1997	Whitfield et al.
5,356,064	A	10/1994	Green et al.	5,702,048	A	12/1997	Eberlin
5,366,458	A	11/1994	Korthoff et al.	5,709,706	A	1/1998	Kienzle et al.
5,366,459	A	11/1994	Yoon	5,713,911	A	2/1998	Racenet et al.
5,368,600	A	11/1994	Failla et al.	5,713,912	A	2/1998	Porter
5,381,943	A	1/1995	Allen et al.	5,720,756	A	2/1998	Green et al.
5,382,253	A	1/1995	Hogendijk	5,722,982	A	3/1998	Ferreira et al.
5,382,254	A	1/1995	McGarry et al.	5,725,537	A	3/1998	Green et al.
5,382,255	A	1/1995	Castro et al.	5,725,538	A	3/1998	Green et al.
5,383,881	A	1/1995	Green et al.	5,725,542	A	3/1998	Yoon
5,395,375	A	3/1995	Turkel et al.	5,733,295	A	3/1998	Back et al.
5,395,381	A	3/1995	Green et al.	5,755,726	A	5/1998	Pratt et al.
5,403,327	A	4/1995	Thornton et al.	5,766,189	A	6/1998	Matsuno
5,409,498	A	4/1995	Braddock et al.	5,769,857	A	6/1998	Reztzov et al.
5,413,584	A	5/1995	Schulze	5,772,673	A	6/1998	Cuny et al.
5,423,835	A	6/1995	Green et al.	5,776,146	A	7/1998	Sackier et al.
5,425,740	A	6/1995	Hutchinson, Jr.	5,776,147	A	7/1998	Dolendo
5,431,667	A	7/1995	Thompson et al.	5,779,718	A	7/1998	Green et al.
5,431,668	A	7/1995	Burbank, III et al.	5,779,720	A	7/1998	Walder-Utz et al.
5,431,669	A	7/1995	Thompson et al.	5,782,844	A	7/1998	Yoon et al.
5,439,468	A	8/1995	Schulze et al.	5,788,698	A	8/1998	Savornin
5,441,509	A	8/1995	Vidal et al.	5,792,149	A	8/1998	Sherts et al.
5,447,513	A	9/1995	Davison et al.	5,792,150	A	8/1998	Pratt et al.
5,449,365	A	9/1995	Green et al.	5,797,922	A	8/1998	Hessel et al.
5,462,555	A	10/1995	Bolanos et al.	5,810,853	A	9/1998	Yoon
5,462,558	A	10/1995	Kolesa et al.	5,817,116	A	10/1998	Takahashi et al.
5,464,416	A	11/1995	Steckel	5,827,306	A	10/1998	Yoon
5,474,566	A	12/1995	Alesi et al.	5,833,695	A	11/1998	Yoon
5,474,567	A	12/1995	Stefanchik et al.	5,833,696	A	11/1998	Whitfield et al.
5,474,572	A	12/1995	Hayhurst	5,833,700	A	11/1998	Fogelberg et al.
5,487,746	A	1/1996	Yu et al.	5,835,199	A	11/1998	Phillips et al.
5,501,693	A	3/1996	Gravener	5,843,097	A	12/1998	Mayenberger et al.
5,509,920	A	4/1996	Phillips et al.	5,843,101	A	12/1998	Fry
5,514,149	A	5/1996	Green et al.	5,846,255	A	12/1998	Casey
5,520,701	A	5/1996	Lerch	5,849,019	A	12/1998	Yoon
5,527,318	A	6/1996	McGarry	5,858,018	A	1/1999	Shipp et al.
5,527,319	A	6/1996	Green et al.	5,861,005	A	1/1999	Kontos
5,527,320	A	6/1996	Carruthers et al.	5,868,759	A	2/1999	Peysner et al.
5,542,949	A	8/1996	Yoon	5,868,761	A	2/1999	Nicholas et al.
5,547,474	A	8/1996	Kloeckl et al.	5,876,410	A	3/1999	Petillo
5,569,274	A	10/1996	Rapacki et al.	5,895,394	A	4/1999	Kienzle et al.
5,571,121	A	11/1996	Heifetz	5,897,565	A	4/1999	Foster
5,575,802	A	11/1996	McQuilkin et al.	5,904,693	A	5/1999	Dicesare et al.
5,582,615	A	12/1996	Foshee et al.	5,913,862	A	6/1999	Ramsey et al.
5,584,840	A	12/1996	Ramsey et al.	5,918,791	A	7/1999	Sorrentino et al.
5,591,178	A	1/1997	Green et al.	5,921,996	A	7/1999	Sherman
5,593,414	A	1/1997	Shipp et al.	5,921,997	A	7/1999	Fogelberg et al.
5,593,421	A	1/1997	Bauer	5,928,251	A	7/1999	Aranyi et al.
5,601,573	A	2/1997	Fogelberg et al.	5,938,667	A	8/1999	Peysner et al.
5,601,574	A	2/1997	Stefanchik et al.	5,951,574	A	9/1999	Stefanchik et al.
5,607,436	A	3/1997	Pratt et al.	5,972,003	A	10/1999	Rousseau et al.
5,618,291	A	4/1997	Thompson et al.	5,976,159	A	11/1999	Bolduc et al.
5,618,306	A	4/1997	Roth et al.	5,993,465	A	11/1999	Shipp et al.
5,620,452	A	4/1997	Yoon	6,004,335	A	12/1999	Vaitekunas et al.
5,626,585	A	5/1997	Mittelstadt et al.	6,009,551	A	12/1999	Sheynblat
5,626,586	A	5/1997	Pistl et al.	6,017,358	A	1/2000	Yoon et al.
5,626,587	A	5/1997	Bishop et al.	6,059,799	A	5/2000	Aranyi et al.
5,626,592	A	5/1997	Phillips et al.	6,099,536	A	8/2000	Petillo
RE35,525	E	6/1997	Stefanchik et al.	6,099,537	A	8/2000	Sugai et al.
5,634,930	A	6/1997	Thornton et al.	6,139,555	A	10/2000	Hart et al.
5,643,291	A	7/1997	Pier et al.	6,210,418	B1	4/2001	Storz et al.
5,645,551	A	7/1997	Green et al.	6,217,590	B1	4/2001	Levinson
5,645,553	A	7/1997	Kolesa et al.	6,228,097	B1	5/2001	Levinson et al.
5,649,937	A	7/1997	Bito et al.	6,241,740	B1	6/2001	Davis et al.
5,653,720	A	8/1997	Johnson et al.	6,258,105	B1	7/2001	Hart et al.
5,662,676	A	9/1997	Koninckx	6,261,302	B1	7/2001	Voegele et al.
5,662,679	A	9/1997	Voss et al.	6,273,898	B1	8/2001	Kienzle et al.
5,665,097	A	9/1997	Baker et al.	6,277,131	B1	8/2001	Kalikow
5,676,676	A	10/1997	Porter	6,306,149	B1	10/2001	Meade
5,681,330	A	10/1997	Hughett et al.	6,318,619	B1	11/2001	Lee
				6,322,571	B1	11/2001	Adams
				6,350,269	B1	2/2002	Shipp et al.
				6,352,541	B1	3/2002	Kienzle et al.
				6,391,035	B1	5/2002	Appleby et al.

(56)

References Cited

U.S. PATENT DOCUMENTS

6,423,079	B1	7/2002	Blake, III	6,955,643	B2	10/2005	Gellman et al.
6,428,548	B1	8/2002	Durgin et al.	6,959,852	B2	11/2005	Shelton, IV et al.
6,440,144	B1	8/2002	Bacher	6,960,218	B2	11/2005	Rennich
6,461,363	B1	10/2002	Gadberry et al.	6,960,221	B2	11/2005	Ho et al.
6,464,710	B1	10/2002	Foster	6,962,594	B1	11/2005	Thevenet
6,494,886	B1	12/2002	Wilk et al.	6,963,792	B1	11/2005	Green
6,517,536	B2	2/2003	Hooven et al.	6,964,363	B2	11/2005	Wales et al.
6,520,972	B2	2/2003	Peters	6,964,668	B2	11/2005	Modesitt et al.
6,527,786	B1	3/2003	Davis et al.	6,966,875	B1	11/2005	Longobardi
6,537,289	B1	3/2003	Kayan et al.	6,966,917	B1	11/2005	Suyker et al.
6,546,935	B2	4/2003	Hooven	6,966,919	B2	11/2005	Sixto, Jr. et al.
6,551,333	B2	4/2003	Kuhns et al.	6,969,391	B1	11/2005	Gazzani
6,569,171	B2	5/2003	DeGuillebon et al.	6,972,023	B2	12/2005	Wayne et al.
6,579,304	B1	6/2003	Hart et al.	6,972,027	B2	12/2005	Fallin et al.
6,599,298	B1	7/2003	Forster et al.	6,973,770	B2	12/2005	Schnipke et al.
6,602,252	B2	8/2003	Mollenauer	6,974,462	B2	12/2005	Sater
6,607,540	B1	8/2003	Shipp	6,974,466	B2	12/2005	Ahmed et al.
6,613,060	B2	9/2003	Adams et al.	6,974,475	B1	12/2005	Wall
6,626,916	B1	9/2003	Yeung et al.	6,981,505	B2	1/2006	Krause et al.
6,626,922	B1	9/2003	Hart et al.	6,981,628	B2	1/2006	Wales
6,648,898	B1	11/2003	Baxter	6,991,635	B2	1/2006	Takamoto et al.
6,652,538	B2	11/2003	Kayan et al.	7,052,504	B2	5/2006	Hughett
6,652,539	B2	11/2003	Shipp et al.	7,056,330	B2	6/2006	Gayton
6,656,193	B2	12/2003	Grant et al.	7,108,703	B2	9/2006	Danitz et al.
6,673,083	B1	1/2004	Kayan et al.	7,144,402	B2	12/2006	Kuester, III
6,676,659	B2	1/2004	Hutchins et al.	7,175,648	B2	2/2007	Nakao
6,679,894	B2	1/2004	Damarati	7,179,265	B2	2/2007	Manetakis et al.
RE38,445	E	2/2004	Pistl et al.	7,207,997	B2	4/2007	Shipp et al.
6,695,854	B1	2/2004	Kayan et al.	7,211,091	B2	5/2007	Fowler et al.
6,706,057	B1	3/2004	Bidoia et al.	7,211,092	B2	5/2007	Hughett
6,716,226	B2	4/2004	Sixto, Jr. et al.	7,214,230	B2	5/2007	Brock et al.
6,723,109	B2	4/2004	Solingen	7,214,232	B2	5/2007	Bowman et al.
6,743,240	B2	6/2004	Smith et al.	7,223,271	B2	5/2007	Muramatsu et al.
6,773,438	B1	8/2004	Knodel et al.	7,232,445	B2	6/2007	Kortenbach et al.
6,773,440	B2	8/2004	Gannoe et al.	7,261,724	B2	8/2007	Molitor et al.
6,776,783	B1	8/2004	Frantzen et al.	7,261,725	B2	8/2007	Binmoeller
6,776,784	B2	8/2004	Ginn	7,264,625	B1	9/2007	Buncke
6,780,195	B2	8/2004	Porat	7,288,098	B2	10/2007	Huitema et al.
6,793,663	B2	9/2004	Kneifel et al.	7,297,149	B2	11/2007	Vitali et al.
6,793,664	B2	9/2004	Mazzocchi et al.	7,316,693	B2	1/2008	Viola
6,802,848	B2	10/2004	Anderson et al.	7,316,696	B2	1/2008	Wilson, Jr. et al.
6,814,742	B2	11/2004	Kimura et al.	7,326,223	B2	2/2008	Wilson, Jr.
6,818,009	B2	11/2004	Hart et al.	7,329,266	B2	2/2008	Royse et al.
6,821,273	B2	11/2004	Mollenauer	7,331,968	B2	2/2008	Arp et al.
6,821,284	B2	11/2004	Sturtz et al.	7,338,503	B2	3/2008	Rosenberg et al.
6,824,547	B2	11/2004	Wilson, Jr. et al.	7,357,805	B2	4/2008	Masuda et al.
6,824,548	B2	11/2004	Smith et al.	7,510,562	B2	3/2009	Lindsay
6,835,199	B2	12/2004	McGuckin, Jr. et al.	7,552,853	B2	6/2009	Mas et al.
6,835,200	B2	12/2004	Laufer et al.	7,637,917	B2	12/2009	Whitfield et al.
6,837,893	B2	1/2005	Miller	7,686,820	B2	3/2010	Huitema et al.
6,837,894	B2	1/2005	Pugsley, Jr. et al.	7,695,482	B2	4/2010	Viola
6,837,895	B2	1/2005	Mayenberger	7,717,926	B2	5/2010	Whitfield et al.
6,840,945	B2	1/2005	Manetakis et al.	7,727,248	B2	6/2010	Smith et al.
6,843,794	B2	1/2005	Sixto, Jr. et al.	7,731,724	B2	6/2010	Huitema et al.
6,849,078	B2	2/2005	Durgin et al.	7,740,641	B2	6/2010	Huitema
6,849,079	B1	2/2005	Blake, III et al.	7,752,853	B2	7/2010	Singh et al.
6,853,879	B2	2/2005	Sunaoshi	7,753,250	B2	7/2010	Clauson et al.
6,863,675	B2*	3/2005	Wilson, Jr. 606/157	7,819,886	B2	10/2010	Whitfield et al.
6,869,435	B2	3/2005	Blake, III	7,887,553	B2	2/2011	Lehman et al.
6,869,436	B2	3/2005	Wendlandt	7,905,890	B2	3/2011	Whitfield et al.
6,889,116	B2	5/2005	Jinno	7,942,885	B2	5/2011	Sixto, Jr. et al.
6,896,682	B1	5/2005	McClellan et al.	7,963,433	B2	6/2011	Whitman et al.
6,905,503	B2	6/2005	Gifford, III et al.	7,988,027	B2	8/2011	Olson et al.
6,911,032	B2	6/2005	Jugenheimer et al.	8,011,550	B2	9/2011	Aranyi et al.
6,911,033	B2	6/2005	de Guillebon et al.	8,011,555	B2	9/2011	Tarinelli et al.
6,913,607	B2	7/2005	Ainsworth et al.	8,016,178	B2	9/2011	Olson et al.
6,916,327	B2	7/2005	Northrup, III et al.	8,021,375	B2	9/2011	Aldrich et al.
6,923,818	B2	8/2005	Muramatsu et al.	8,021,378	B2	9/2011	Sixto, Jr. et al.
6,939,356	B2	9/2005	Debbas	8,038,686	B2	10/2011	Huitema et al.
6,942,674	B2	9/2005	Belef et al.	8,056,565	B2	11/2011	Zergiebel
6,942,676	B2	9/2005	Buelna	8,062,310	B2	11/2011	Shibata et al.
6,945,978	B1	9/2005	Hyde	8,066,720	B2	11/2011	Knodel et al.
6,945,979	B2	9/2005	Kortenbach et al.	8,066,721	B2	11/2011	Kortenbach et al.
6,949,107	B2	9/2005	McGuckin, Jr. et al.	8,066,722	B2	11/2011	Miyagi et al.
6,953,465	B2	10/2005	Dieck et al.	8,070,760	B2	12/2011	Fujita
				8,075,571	B2	12/2011	Vitali et al.
				8,080,021	B2	12/2011	Griego
				8,083,668	B2	12/2011	Durgin et al.
				8,088,061	B2	1/2012	Wells et al.

(56)

References Cited

U.S. PATENT DOCUMENTS

8,091,755 B2	1/2012	Kayan et al.	8,968,337 B2	3/2015	Whitfield et al.
8,100,926 B1	1/2012	Filshie et al.	8,973,804 B2	3/2015	Hess et al.
8,128,643 B2	3/2012	Aranyi et al.	9,011,464 B2	4/2015	Zammataro
8,133,240 B2	3/2012	Damarati	9,011,465 B2	4/2015	Whitfield et al.
8,142,451 B2	3/2012	Boulnois et al.	2001/0047178 A1	11/2001	Peters
8,157,149 B2	4/2012	Olson et al.	2002/0040226 A1	4/2002	Lauffer et al.
8,157,151 B2	4/2012	Ingmanson et al.	2002/0068947 A1	6/2002	Kuhns et al.
8,172,859 B2	5/2012	Matsuno et al.	2002/0082618 A1	6/2002	Shipp et al.
8,172,870 B2	5/2012	Shipp	2002/0087169 A1	7/2002	Brock et al.
8,187,290 B2	5/2012	Buckman et al.	2002/0087170 A1	7/2002	Kuhns et al.
8,211,120 B2	7/2012	Itoh	2002/0099388 A1	7/2002	Mayenberger
8,211,124 B2	7/2012	Ainsworth et al.	2002/0120279 A1	8/2002	Deguillebon et al.
8,216,255 B2	7/2012	Smith et al.	2002/0128668 A1	9/2002	Manetakis et al.
8,216,257 B2	7/2012	Huitema et al.	2002/0177859 A1	11/2002	Monassevitch et al.
8,236,012 B2	8/2012	Molitor et al.	2002/0198537 A1	12/2002	Smith et al.
8,246,634 B2	8/2012	Huitema et al.	2002/0198538 A1	12/2002	Kortenbach et al.
8,246,635 B2	8/2012	Huitema	2002/0198539 A1	12/2002	Sixto et al.
8,262,678 B2	9/2012	Matsuoka et al.	2002/0198540 A1	12/2002	Smith et al.
8,262,679 B2	9/2012	Nguyen	2002/0198541 A1	12/2002	Smith et al.
8,267,944 B2	9/2012	Sorrentino et al.	2003/0014060 A1	1/2003	Wilson et al.
8,267,945 B2	9/2012	Nguyen et al.	2003/0018345 A1	1/2003	Green
8,267,946 B2	9/2012	Whitfield et al.	2003/0023249 A1	1/2003	Manetakis
8,282,655 B2	10/2012	Whitfield et al.	2003/0040759 A1	2/2003	de Guillebon et al.
8,308,743 B2	11/2012	Matsuno et al.	2003/0105476 A1	6/2003	Sancoff et al.
8,328,822 B2	12/2012	Huitema et al.	2003/0114867 A1	6/2003	Bolduc et al.
8,336,556 B2	12/2012	Zergiebel	2003/0135224 A1	7/2003	Blake
8,348,130 B2	1/2013	Shah et al.	2003/0167063 A1	9/2003	Kerr
8,357,171 B2	1/2013	Whitfield et al.	2003/0208231 A1	11/2003	Williamson et al.
8,366,726 B2	2/2013	Dennis	2003/0220657 A1	11/2003	Adams
8,371,491 B2	2/2013	Huitema et al.	2003/0225423 A1	12/2003	Huitema
8,372,095 B2	2/2013	Viola	2003/0229360 A1	12/2003	Gayton
8,382,773 B2	2/2013	Whitfield et al.	2003/0233105 A1	12/2003	Gayton
8,398,655 B2	3/2013	Cheng et al.	2004/0010272 A1	1/2004	Manetakis et al.
8,403,945 B2	3/2013	Whitfield et al.	2004/0044352 A1	3/2004	Fowler et al.
8,403,946 B2	3/2013	Whitfield et al.	2004/0097970 A1	5/2004	Hughett
8,409,222 B2	4/2013	Whitfield et al.	2004/0097971 A1	5/2004	Hughett
8,409,223 B2	4/2013	Sorrentino et al.	2004/0097972 A1	5/2004	Shipp et al.
8,419,752 B2	4/2013	Sorrentino et al.	2004/0106936 A1	6/2004	Shipp et al.
8,430,892 B2	4/2013	Bindra et al.	2004/0133215 A1	7/2004	Baxter
8,444,660 B2	5/2013	Adams et al.	2004/0138681 A1	7/2004	Pier
8,465,502 B2	6/2013	Zergiebel	2004/0153100 A1	8/2004	Ahlberg et al.
8,475,473 B2	7/2013	Vandenbroek et al.	2004/0158266 A1	8/2004	Damarati
8,480,688 B2	7/2013	Boulnois et al.	2004/0162567 A9	8/2004	Adams
8,486,091 B2	7/2013	Sorrentino et al.	2004/0167545 A1	8/2004	Sadler et al.
8,491,608 B2	7/2013	Sorrentino et al.	2004/0176776 A1	9/2004	Zubok et al.
8,496,673 B2	7/2013	Nguyen et al.	2004/0176783 A1	9/2004	Edoga et al.
8,506,580 B2	8/2013	Zergiebel et al.	2004/0176784 A1	9/2004	Okada
8,512,357 B2	8/2013	Viola	2004/0193213 A1	9/2004	Aranyi et al.
8,523,882 B2	9/2013	Huitema et al.	2005/0080440 A1	4/2005	Durgin et al.
8,529,585 B2	9/2013	Jacobs et al.	2005/0090837 A1	4/2005	Sixto et al.
8,529,586 B2	9/2013	Rosenberg et al.	2005/0090838 A1	4/2005	Sixto et al.
8,529,588 B2	9/2013	Ahlberg et al.	2005/0096670 A1	5/2005	Wellman et al.
8,545,486 B2	10/2013	Malkowski	2005/0096672 A1	5/2005	Wellman et al.
8,556,920 B2	10/2013	Huitema et al.	2005/0101975 A1	5/2005	Manetakis et al.
8,568,430 B2	10/2013	Shipp	2005/0101975 A1	5/2005	Nguyen et al.
8,579,918 B2	11/2013	Whitfield et al.	2005/0107807 A1	5/2005	Nakao
8,585,717 B2	11/2013	Sorrentino et al.	2005/0107809 A1	5/2005	Litscher et al.
8,603,109 B2	12/2013	Aranyi et al.	2005/0107810 A1	5/2005	Morales et al.
8,652,151 B2	2/2014	Lehman et al.	2005/0107811 A1	5/2005	Starksen et al.
8,652,152 B2	2/2014	Aranyi et al.	2005/0107812 A1	5/2005	Starksen et al.
8,663,247 B2	3/2014	Menn et al.	2005/0107871 A1	5/2005	Realyvasquez et al.
8,685,048 B2	4/2014	Adams et al.	2005/0113847 A1	5/2005	Gadberry et al.
8,690,899 B2	4/2014	Kogiso et al.	2005/0119671 A1	6/2005	Reydel et al.
8,709,027 B2	4/2014	Adams et al.	2005/0119673 A1	6/2005	Gordon et al.
8,720,766 B2	5/2014	Hess et al.	2005/0119677 A1	6/2005	Shipp
8,734,469 B2	5/2014	Pribanic et al.	2005/0125010 A1	6/2005	Smith et al.
8,747,423 B2	6/2014	Whitfield et al.	2005/0143767 A1	6/2005	Kimura et al.
8,753,356 B2	6/2014	Vitali et al.	2005/0149063 A1	7/2005	Young et al.
8,821,516 B2	9/2014	Huitema	2005/0149064 A1	7/2005	Peterson et al.
8,839,954 B2	9/2014	Disch	2005/0149068 A1	7/2005	Williams et al.
8,845,659 B2	9/2014	Whitfield et al.	2005/0149069 A1	7/2005	Bertolero et al.
8,894,665 B2	11/2014	Sorrentino et al.	2005/0165415 A1	7/2005	Wales
8,894,666 B2	11/2014	Schulz et al.	2005/0165418 A1	7/2005	Chan
8,920,438 B2	12/2014	Aranyi et al.	2005/0171560 A1	8/2005	Hughett
8,961,542 B2	2/2015	Whitfield et al.	2005/0175703 A1	8/2005	Hunter et al.
			2005/0177176 A1	8/2005	Gerbi et al.
			2005/0203547 A1	9/2005	Weller et al.
			2005/0203548 A1	9/2005	Weller et al.
			2005/0216036 A1	9/2005	Nakao

(56)

References Cited

U.S. PATENT DOCUMENTS

2005/0216056	A1	9/2005	Valdevit et al.	2007/0083218	A1	4/2007	Morris
2005/0222588	A1	10/2005	Vandenbroek et al.	2007/0106314	A1	5/2007	Dunn
2005/0222590	A1	10/2005	Gadberry et al.	2007/0112365	A1	5/2007	Hilal et al.
2005/0222665	A1	10/2005	Aranyi	2007/0118155	A1	5/2007	Goldfarb et al.
2005/0228411	A1	10/2005	Manzo	2007/0118161	A1	5/2007	Kennedy et al.
2005/0228416	A1	10/2005	Burbank et al.	2007/0118163	A1	5/2007	Boudreaux et al.
2005/0234478	A1	10/2005	Wixey et al.	2007/0118174	A1	5/2007	Chu
2005/0251183	A1	11/2005	Buckman et al.	2007/0123916	A1	5/2007	Maier et al.
2005/0251184	A1	11/2005	Anderson	2007/0142848	A1	6/2007	Ainsworth et al.
2005/0256529	A1	11/2005	Yawata et al.	2007/0142851	A1	6/2007	Sixto et al.
2005/0267495	A1	12/2005	Ginn et al.	2007/0149988	A1	6/2007	Michler et al.
2005/0273122	A1	12/2005	Theroux et al.	2007/0149989	A1	6/2007	Santilli et al.
2005/0277951	A1	12/2005	Smith et al.	2007/0162060	A1	7/2007	Wild
2005/0277952	A1	12/2005	Arp et al.	2007/0173866	A1	7/2007	Sorrentino et al.
2005/0277953	A1	12/2005	Francese et al.	2007/0185504	A1	8/2007	Manetakis et al.
2005/0277954	A1	12/2005	Smith et al.	2007/0191868	A1	8/2007	Theroux et al.
2005/0277955	A1	12/2005	Palmer et al.	2007/0203509	A1	8/2007	Bettuchi
2005/0277956	A1	12/2005	Francese et al.	2007/0203510	A1	8/2007	Bettuchi
2005/0277958	A1	12/2005	Levinson	2007/0213747	A1	9/2007	Monassevitch et al.
2005/0288689	A1	12/2005	Kammerer et al.	2007/0250080	A1	10/2007	Jones et al.
2005/0288690	A1	12/2005	Bourque et al.	2007/0265640	A1	11/2007	Kortenbach et al.
2006/0004388	A1	1/2006	Whayne et al.	2007/0276417	A1	11/2007	Mendes, Jr. et al.
2006/0004390	A1	1/2006	Rosenberg et al.	2007/0282355	A1	12/2007	Brown et al.
2006/0009789	A1	1/2006	Gambale et al.	2007/0288039	A1	12/2007	Aranyi et al.
2006/0009790	A1	1/2006	Blake et al.	2007/0293875	A1	12/2007	Soetikno et al.
2006/0009792	A1	1/2006	Baker et al.	2008/0004636	A1	1/2008	Walberg et al.
2006/0020270	A1	1/2006	Jabba et al.	2008/0004637	A1	1/2008	Klassen et al.
2006/0020271	A1	1/2006	Stewart et al.	2008/0004639	A1	1/2008	Huitema et al.
2006/0047305	A1	3/2006	Ortiz et al.	2008/0015615	A1	1/2008	Molitor et al.
2006/0047306	A1	3/2006	Ortiz et al.	2008/0027465	A1	1/2008	Vitali et al.
2006/0064117	A1	3/2006	Aranyi et al.	2008/0027466	A1	1/2008	Vitali et al.
2006/0079115	A1	4/2006	Aranyi et al.	2008/0045981	A1	2/2008	Margolin et al.
2006/0079913	A1	4/2006	Whitfield et al.	2008/0051808	A1	2/2008	Rivera et al.
2006/0100649	A1	5/2006	Hart	2008/0065118	A1	3/2008	Damarati
2006/0111731	A1	5/2006	Manzo	2008/0083813	A1	4/2008	Zemlok et al.
2006/0129170	A1	6/2006	Royce et al.	2008/0103510	A1	5/2008	Taylor et al.
2006/0135992	A1	6/2006	Bettuchi et al.	2008/0147092	A1	6/2008	Rogge et al.
2006/0163312	A1	7/2006	Viola et al.	2008/0147093	A1	6/2008	Roskopf et al.
2006/0173470	A1	8/2006	Oray et al.	2008/0154287	A1	6/2008	Rosenberg et al.
2006/0178683	A1	8/2006	Shimoji et al.	2008/0167665	A1	7/2008	Arp et al.
2006/0184182	A1	8/2006	Aranyi et al.	2008/0228199	A1	9/2008	Cropper et al.
2006/0190013	A1	8/2006	Menn	2008/0243145	A1	10/2008	Whitfield et al.
2006/0195125	A1	8/2006	Sakakine et al.	2008/0255589	A1	10/2008	Blakeney et al.
2006/0200179	A1	9/2006	Barker et al.	2008/0306492	A1	12/2008	Shibata et al.
2006/0212050	A1	9/2006	D'Agostino et al.	2008/0306493	A1	12/2008	Shibata et al.
2006/0217749	A1	9/2006	Wilson et al.	2008/0312665	A1	12/2008	Shibata et al.
2006/0224165	A1	10/2006	Surti et al.	2008/0319456	A1	12/2008	Hart
2006/0224170	A1	10/2006	Duff	2009/0076533	A1	3/2009	Kayan et al.
2006/0235437	A1	10/2006	Vitali et al.	2009/0088777	A1	4/2009	Miyagi et al.
2006/0235438	A1	10/2006	Huitema et al.	2009/0088783	A1	4/2009	Kennedy et al.
2006/0235439	A1	10/2006	Molitor et al.	2009/0171380	A1	7/2009	Whiting
2006/0235440	A1	10/2006	Huitema et al.	2009/0222003	A1	9/2009	Otley
2006/0235441	A1	10/2006	Huitema et al.	2009/0228023	A1	9/2009	Cui
2006/0235442	A1	10/2006	Huitema	2009/0228024	A1	9/2009	Whitfield et al.
2006/0235443	A1	10/2006	Huitema et al.	2009/0264904	A1	10/2009	Aldrich et al.
2006/0235444	A1	10/2006	Huitema et al.	2009/0326558	A1	12/2009	Cui et al.
2006/0235445	A1	11/2006	Damarati	2010/0057105	A1	3/2010	Sorrentino et al.
2006/0259049	A1	11/2006	Harada et al.	2010/0057107	A1	3/2010	Sorrentino et al.
2006/0264987	A1	11/2006	Sgro	2010/0274262	A1	10/2010	Schulz et al.
2006/0271072	A1	11/2006	Hummel et al.	2010/0274264	A1	10/2010	Schulz et al.
2007/0016228	A1	1/2007	Salas	2011/0054498	A1	3/2011	Monassevitch et al.
2007/0021761	A1	1/2007	Phillips	2011/0087241	A1	4/2011	Nguyen
2007/0023476	A1	2/2007	Whitman et al.	2011/0087243	A1	4/2011	Nguyen et al.
2007/0023477	A1	2/2007	Whitman et al.	2011/0112552	A1	5/2011	Lehman et al.
2007/0027458	A1	2/2007	Sixto, Jr. et al.	2011/0137323	A1	6/2011	Malkowski et al.
2007/0034669	A1	2/2007	de la Torre et al.	2011/0137324	A1	6/2011	Boudreaux et al.
2007/0038233	A1	2/2007	Martinez et al.	2011/0144662	A1	6/2011	McLawnhorn et al.
2007/0049947	A1	3/2007	Menn et al.	2011/0190791	A1	8/2011	Jacobs et al.
2007/0049948	A1	3/2007	Menn et al.	2011/0208212	A1	8/2011	Zergiebel et al.
2007/0049949	A1	3/2007	Manetakis	2011/0218553	A1	9/2011	Huitema et al.
2007/0049950	A1	3/2007	Theroux et al.	2011/0218554	A1	9/2011	Cheng et al.
2007/0049951	A1	3/2007	Menn	2011/0218555	A1	9/2011	Huitema
2007/0049953	A2	3/2007	Shimoji et al.	2011/0218556	A1	9/2011	Nguyen et al.
2007/0066981	A1	3/2007	Meagher	2011/0224696	A1	9/2011	Huitema et al.
2007/0073314	A1	3/2007	Gadberry et al.	2011/0224700	A1	9/2011	Schmidt et al.
				2011/0224701	A1	9/2011	Menn
				2011/0230900	A1	9/2011	Sarradon
				2011/0245847	A1	10/2011	Menn et al.
				2011/0245848	A1	10/2011	Rosenberg et al.

(56)

References Cited

U.S. PATENT DOCUMENTS

2011/0295290 A1 12/2011 Whitfield
 2011/0313437 A1 12/2011 Yeh
 2012/0029534 A1 2/2012 Whitfield et al.
 2012/0041455 A1 2/2012 Martinez
 2012/0046671 A1 2/2012 Matsuoka et al.
 2012/0059394 A1 3/2012 Brenner et al.
 2012/0065647 A1 3/2012 Litscher et al.
 2012/0109158 A1 5/2012 Zammataro
 2012/0116420 A1 5/2012 Sorrentino et al.
 2012/0197269 A1 8/2012 Zammataro
 2012/0265220 A1 10/2012 Menn
 2012/0277765 A1 11/2012 Zammataro et al.
 2012/0330326 A1 12/2012 Creston et al.
 2013/0110135 A1 5/2013 Whitfield et al.
 2013/0131697 A1 5/2013 Hartoumbekis
 2013/0165951 A1 6/2013 Blake, III
 2013/0165952 A1 6/2013 Whitfield et al.
 2013/0172910 A1 7/2013 Malkowski
 2013/0172911 A1 7/2013 Rockrohr et al.
 2013/0172912 A1 7/2013 Whitfield et al.
 2013/0253541 A1 9/2013 Zergiebel
 2013/0274767 A1 10/2013 Sorrentino et al.
 2013/0289583 A1 10/2013 Zergiebel et al.
 2013/0296891 A1 11/2013 Hartoumbekis
 2013/0296892 A1 11/2013 Sorrentino et al.
 2013/0310849 A1 11/2013 Malkowski
 2013/0325040 A1 12/2013 Zammataro
 2014/0005693 A1 1/2014 Shelton, IV et al.
 2014/0039526 A1 2/2014 Malkowski
 2014/0052157 A1 2/2014 Whitfield et al.
 2014/0058412 A1 2/2014 Aranyi et al.
 2014/0194903 A1 7/2014 Malkowski et al.
 2014/0207156 A1 7/2014 Malkowski
 2014/0316441 A1 10/2014 Zergiebel et al.
 2014/0330291 A1 11/2014 Whitfield et al.
 2015/0005790 A1 1/2015 Whitfield et al.
 2015/0032131 A1 1/2015 Sorrentino et al.
 2015/0066057 A1 3/2015 Rockrohr et al.
 2015/0080916 A1 3/2015 Aranyi et al.
 2015/0127022 A1 5/2015 Whitfield et al.

FOREIGN PATENT DOCUMENTS

CN 100571640 C 12/2009
 CN 101658437 A 3/2010
 CN 101664329 A 3/2010
 CN 101664331 A 3/2010
 CN 201683954 U 12/2010
 CN 103083059 A 5/2013
 CN 103181809 A 7/2013
 CN 103181810 A 7/2013
 CN 104487006 A 4/2015
 EP 0 073 655 A1 3/1983
 EP 0 086 721 A2 8/1983
 EP 0 089 737 A1 9/1983
 EP 0 092 300 A1 10/1983
 EP 0324166 A2 7/1989
 EP 0 392 750 A1 10/1990
 EP 0 406 724 A1 1/1991
 EP 0 409 569 A1 1/1991
 EP 0 569 223 A1 11/1993
 EP 0 594 003 A1 4/1994
 EP 0 598 529 A2 5/1994
 EP 0 622 049 A1 11/1994
 EP 0 685 204 A1 12/1995
 EP 0 732 078 A2 9/1996
 EP 0 755 655 A2 1/1997
 EP 0 760 230 A1 3/1997
 EP 0 769 274 A1 4/1997
 EP 0 769 275 A1 4/1997
 EP 0 834 286 A1 4/1998
 EP 1 317 906 A1 6/2003
 EP 1 609 427 A1 12/2005
 EP 1 712 187 A2 10/2006
 EP 1 712 191 A2 10/2006

EP 1 757 236 A2 2/2007
 EP 1813199 A1 8/2007
 EP 1 894 531 A2 3/2008
 EP 1 908 423 A2 4/2008
 EP 1 913 881 A1 4/2008
 EP 1 939 231 A1 7/2008
 EP 2 229 895 A1 9/2010
 EP 2 332 471 A1 6/2011
 EP 2 412 318 A2 2/2012
 EP 2 412 319 A2 2/2012
 EP 2 752 165 A2 7/2014
 GB 1134832 A 11/1968
 GB 2073022 A 10/1981
 GB 2 132 899 A 7/1984
 JP 10-118083 A 5/1998
 JP 2003-033361 A 2/2003
 JP 2006-501954 A 1/2006
 JP 2006-154230 A 6/2006
 JP 2006-209948 A 8/2006
 JP 2006-277221 A 10/2006
 JP 2007-250843 A 9/2007
 JP 2008-017876 A 1/2008
 JP 2008-055165 A 3/2008
 JP 2008-515550 A 5/2008
 JP 2009-198991 A 9/2009
 WO 01/65997 A2 9/2001
 WO 01-66001 A2 9/2001
 WO 01-67965 A1 9/2001
 WO 03-086207 A1 10/2003
 WO 03-092473 A2 11/2003
 WO 2004-032762 A1 4/2004
 WO 2005-091457 A1 9/2005
 WO 2006-042076 A2 4/2006
 WO 2006-042084 A2 4/2006
 WO 2006-042110 A2 4/2006
 WO 2006-042141 A2 4/2006
 WO 2006-135479 A2 12/2006
 WO 2008-118928 A2 10/2008
 WO 2008-127968 A2 10/2008

OTHER PUBLICATIONS

International Search Report corresponding to International Application No. PCT-US08-58185, completed Sep. 4, 2008; mailed Sep. 9, 2008; (2 Pages).
 International Search Report corresponding to International Application No. PCT-US08-59859, completed Sep. 14, 2008; mailed Sep. 18, 2008; (2 Pages).
 Extended European Search Report corresponding to European Application No. EP 07 25 3807.7, completed Nov. 7, 2008; mailed Nov. 26, 2008; (11 Pages).
 Extended European Search Report corresponding to European Application No. EP 09 25 2049.3, completed Dec. 11, 2009; mailed Jan. 12, 2010; (3 Pages).
 Extended European Search Report corresponding to European Application No. EP 09 25 2050.1, completed Dec. 23, 2009; mailed Jan. 21, 2010; (3 Pages).
 Extended European Search Report corresponding to European Application No. EP 09 25 2051.9, completed Dec. 21, 2009; mailed Jan. 28, 2010; (3 Pages).
 Extended European Search Report corresponding to European Application No. EP 09 25 2052.7, completed Nov. 16, 2009; mailed Nov. 24, 2009; (3 Pages).
 Extended European Search Report corresponding to European Application No. EP 09 25 2053.5, completed Nov. 24, 2009; mailed Dec. 1, 2009; (3 Pages).
 Extended European Search Report corresponding to European Application No. EP 09 25 2054.3, completed Jan. 7, 2010; mailed Jan. 22, 2010; (3 Pages).
 Extended European Search Report corresponding to European Application No. EP 09 25 2056.8, completed Jan. 8, 2010; mailed Feb. 5, 2010; (3 Pages).
 Extended European Search Report corresponding to European Application No. EP 10 25 0497.4, completed May 4, 2010; mailed May 12, 2010; (6 Pages).

(56)

References Cited

OTHER PUBLICATIONS

Extended European Search Report corresponding to European Application No. EP 10 25 2079.8, completed Mar. 8, 2011; mailed Mar. 17, 2011; (3 Pages).

European Search Report corresponding to European Application No. EP 05 81 0218.7, completed Apr. 18, 2011; mailed May 20, 2011; (3 pages).

European Search Report corresponding to European Application No. EP 05 80 7612.6, completed May 2, 2011; mailed May 20, 2011; (3 pages).

Extended European Search Report corresponding to European Application No. EP 10 25 1737.2, completed May 9, 2011; mailed May 20, 2011; (4 pages).

Extended European Search Report corresponding to European Application No. EP 11 25 0214.1, completed May 25, 2011; mailed Jun. 1, 2011; (3 Pages).

Extended European Search Report corresponding to European Application No. EP 11 00 2681.2, completed May 31, 2011; mailed Jun. 10, 2011; (3 Pages).

European Search Report corresponding to European Application No. EP 05 80 2686.5, completed Jan. 9, 2012; mailed Jan. 18, 2012; (3 Pages).

Extended European Search Report corresponding to European Application No. EP 12 15 1313.9, completed Mar. 20, 2012 and mailed Apr. 12, 2012; (5 Pages).

Extended European Search Report corresponding to European Application No. EP 12 16 1291.5, completed Apr. 24, 2012 and mailed May 4, 2012; (5 Pages).

Extended European Search Report corresponding to European Application No. EP 12 16 5891.8, completed Jun. 12, 2012 and mailed Jun. 20, 2012; (6 Pages).

Extended European Search Report corresponding to European Application No. EP 12 16 2288.0, completed Jun. 4, 2012 and mailed Jul. 7, 2012; (6 Pages).

Extended European Search Report corresponding to European Application No. EP 12 16 4955.2, completed Aug. 23, 2012 and mailed Sep. 4, 2012; (5 Pages).

Extended European Search Report corresponding to European Application No. EP 11 25 0754.6, completed Oct. 22, 2012 and mailed Oct. 31, 2012; (6 Pages).

Extended European Search Report corresponding to European Application No. EP 12 18 6401.1, completed Nov. 22, 2012 and mailed Nov. 30, 2012; (7 Pages).

Extended European Search Report corresponding to European Application No. EP 12 18 6448.2, completed Nov. 28, 2012 and mailed Dec. 10, 2012; (6 Pages).

Extended European Search Report corresponding to European Application No. EP 12 19 1706.6, completed Dec. 19, 2012 and mailed Jan. 8, 2013; (6 Pages).

Extended European Search Report corresponding to EP 12 19 8745.7, completed Mar. 19, 2013 and mailed Apr. 11, 2013; (8 Pages).

Extended European Search Report corresponding to EP 12 15 2989.5, completed Apr. 9, 2013 and mailed Apr. 18, 2013; (9 Pages).

Extended European Search Report corresponding to EP 08 73 2820.9, completed Jul. 2, 2013 and mailed Jul. 9, 2013; (10 Pages).

Extended European Search Report corresponding to EP 13 17 2008.8, completed Aug. 14, 2013 and mailed Aug. 28, 2013; (8 Pages).

Extended European Search Report corresponding to EP 13 16 6382.5, completed Nov. 19, 2013 and mailed Nov. 28, 2013; (8 Pages).

Extended European Search Report corresponding to EP 11 25 0194.5, completed Nov. 25, 2013 and mailed Dec. 3, 2013; (8 Pages).

Extended European Search Report corresponding to EP 10 25 1798.4, completed Dec. 12, 2013 and mailed Jan. 2, 2014; (9 Pages).
 "Salute II Disposable Fixation Device", Technique Guide—Laparoscopic and Open Inguinal and Ventral Hernia Repair; Davol, A Bard Company, 2006; (7 Pages).

Extended European Search Report corresponding to EP 10 25 2112.7, completed Jul. 29, 2014 and mailed Aug. 5, 2014; (8 pp).
 Extended European Search Report corresponding to EP 14 15 1673.2, completed Apr. 25, 2014 and mailed May 8, 2014; (8 pp).
 Australian Examination Report corresponding to AU 2011211463 dated Apr. 13, 2015; 3 pages.

Japanese Office Action corresponding to JP 2011-160130 mailed Dec. 1, 2014.

Chinese Office Action corresponding to CN 201210015011.8 issued Jan. 4, 2015.

Japanese Office Action corresponding to JP 2011-160126 mailed Jan. 9, 2015.

Japanese Office Action corresponding to JP 2011-184521 mailed Jan. 15, 2015.

Extended European Search Report corresponding to 14 18 2236.1 dated Jan. 20, 2015.

Chinese Office Action corresponding to CN 201110201736.1 issued Feb. 9, 2015.

Extended European Search Report corresponding to EP 14 16 1540.1 dated Feb. 27, 2015.

Australian Office Action corresponding to AU 2010226985 issued Mar. 31, 2015.

Australian Office Action corresponding to AU 2013211526 issued Apr. 6, 2015.

Australian Office Action corresponding to AU 2011211463 issued Apr. 13, 2015.

Australian Office Action corresponding to AU 2013254887 issued Apr. 14, 2015.

Japanese Office Action corresponding to JP 2013-225272 mailed May 1, 2015.

European Office Action corresponding to EP 12 152 989.5 dated May 4, 2015.

Australian Office Action corresponding to AU 2009212759 issued May 7, 2015.

Japanese Office Action corresponding to JP 2013-229070 mailed May 8, 2015.

Japanese Office Action corresponding to JP 2013-229996 mailed May 8, 2015.

European office action received from corresponding EP 11250754.6 dated Jul. 22, 2015.

Chinese First Office Action corresponding to counterpart Int'l Appln. No. CN 201210586826.1 dated Dec. 30, 2015.

Extended European Search Report corresponding to counterpart Int'l Appln. No. EP 15 19 1313.4 dated Feb. 1, 2016.

Extended European Search Report corresponding to counterpart Int'l Appln. No. EP 15 18 5362.9 dated Feb. 12, 2016.

Extended European Search Report corresponding to counterpart Int'l Appln. No. EP 12 19 7813.4 dated Mar. 7, 2016.

Canadian Office Action corresponding to counterpart Int'l Appln. No. CA 2,676,465 dated Mar. 8, 2016.

Japanese Office Action corresponding to counterpart Int'l Appln. No. JP 2014-245081 dated Mar. 18, 2016.

Japanese Office Action corresponding to counterpart Int'l Appln. No. JP 2015-005629 dated Mar. 18, 2016.

Extended European Search Report corresponding to counterpart Int'l Appln. No. EP 15 19 3549.1 dated Mar. 22, 2016.

International Search Report and Written Opinion corresponding to counterpart Int'l Appln. No. PCT/CN2015/082199 dated Mar. 31, 2016.

Extended European Search Report corresponding to counterpart Int'l Appln. No. EP 15 19 7251.0 dated Apr. 8, 2016.

Extended European Search Report corresponding to counterpart Int'l Appln. No. EP 16 15 0739.7 dated May 17, 2016.

Canadian Office Action corresponding to counterpart Int'l Appln. No. CA 2,716,672 dated May 31, 2016.

Canadian Office Action corresponding to counterpart Int'l Appln. No. CA 2,717,448 dated May 31, 2016.

Canadian Office Action corresponding to counterpart Int'l Appln. No. CA 2,721,951 dated Jun. 1, 2016.

Partial European Search Report corresponding to counterpart Int'l Appln. No. EP 16 15 0287.7 dated Jun. 16, 2016.

Chinese Second Office Action corresponding to counterpart Int'l Appln. No. CN 201210555570.8 dated Jun. 20, 2016.

(56)

References Cited

OTHER PUBLICATIONS

International Search Report & Written Opinion corresponding to
Int'l Appln. No. PCT/CN2015/091603 dated Jul. 8, 2016.
Chinese Office Action issued in corresponding application No.
201510419902.3 on Jan. 4, 2017.

* cited by examiner

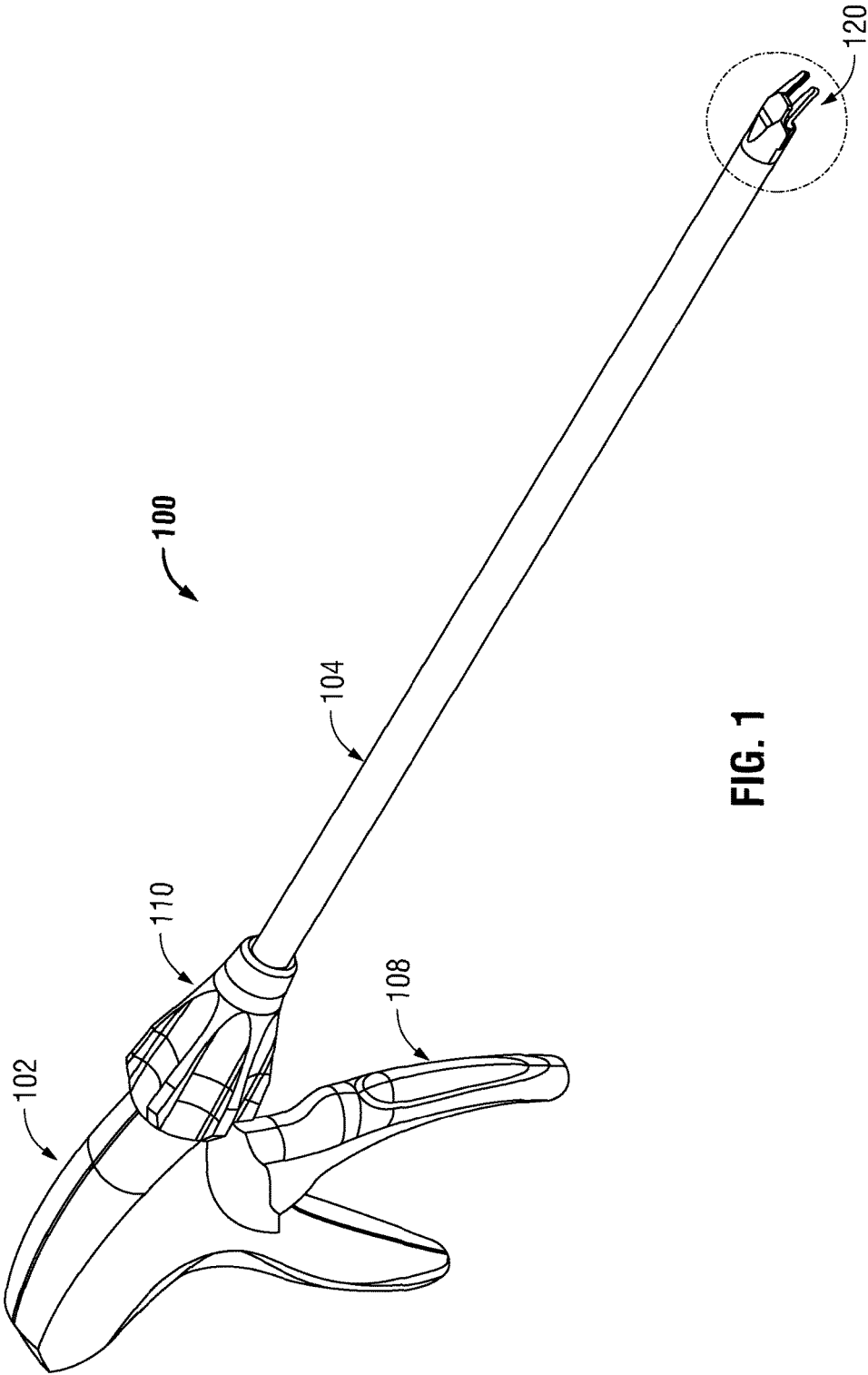

FIG. 1

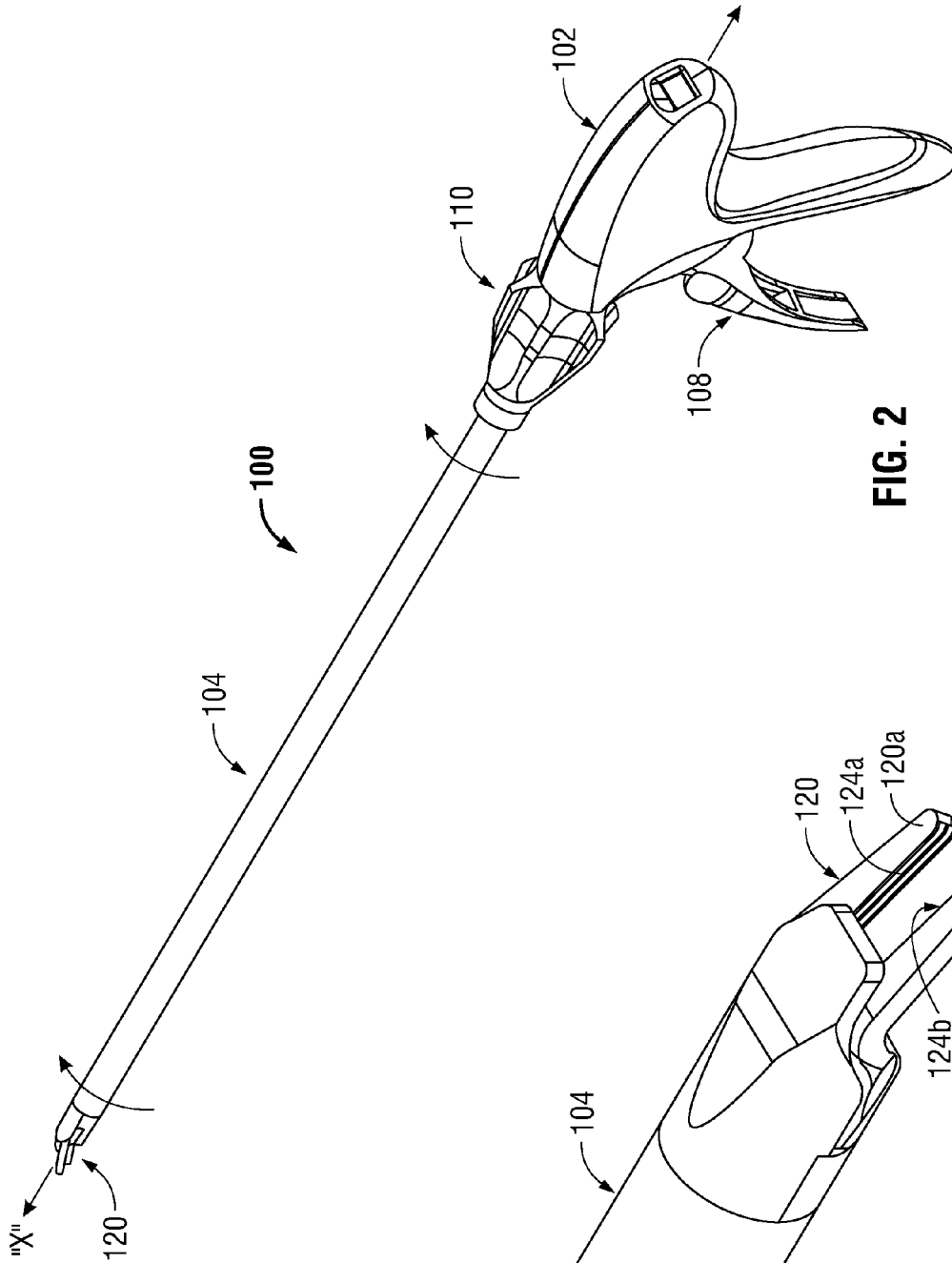

FIG. 2

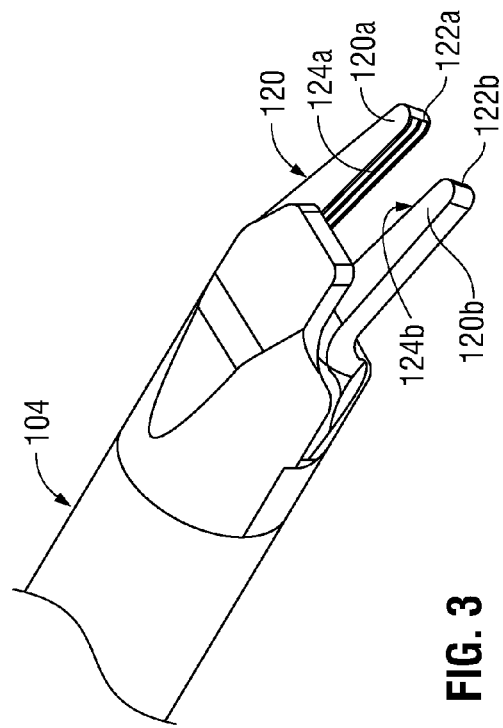

FIG. 3

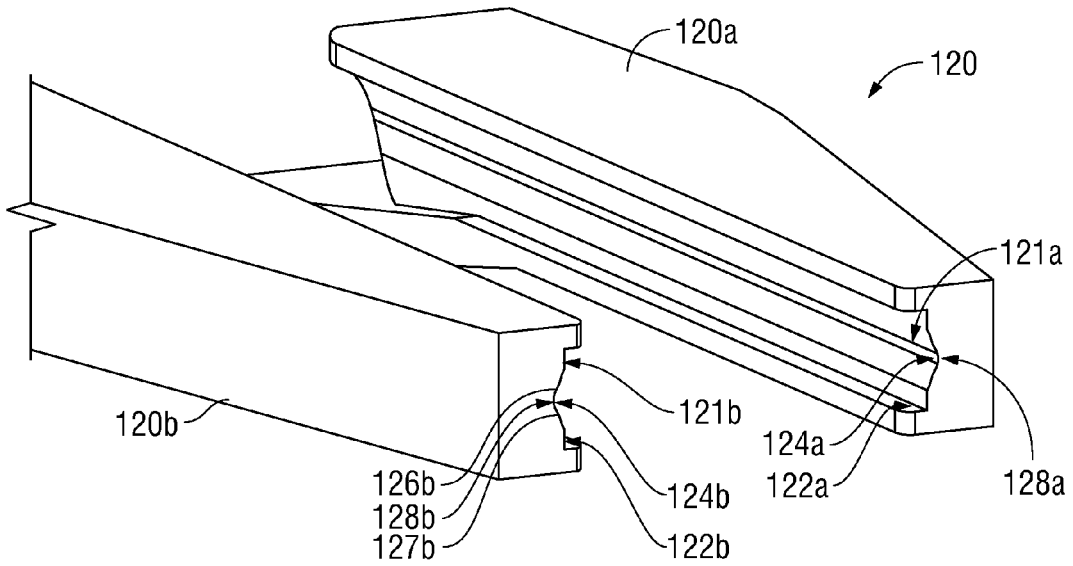

FIG. 4

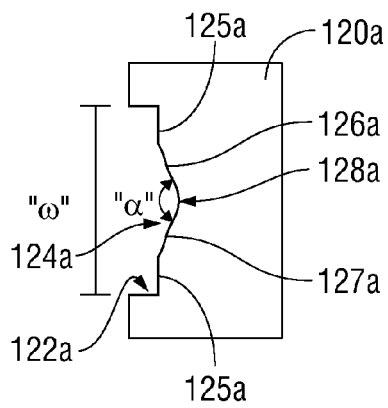

FIG. 5

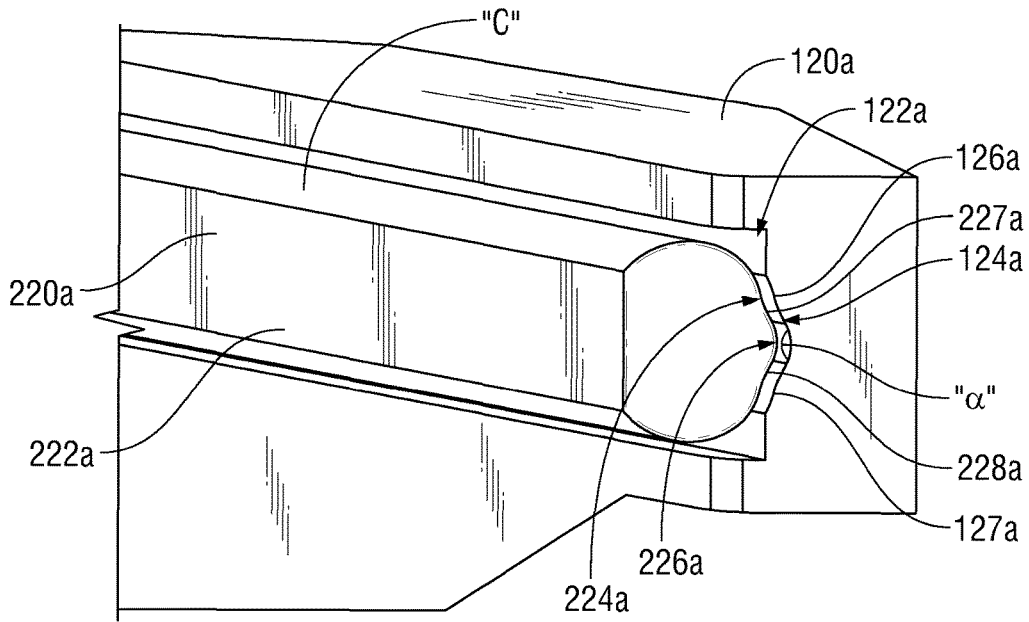

FIG. 6

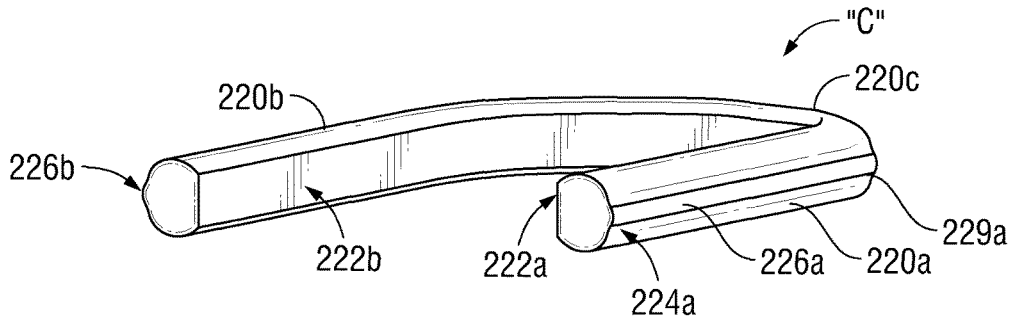

FIG. 7

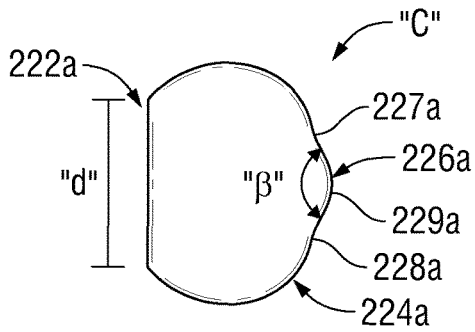

FIG. 8

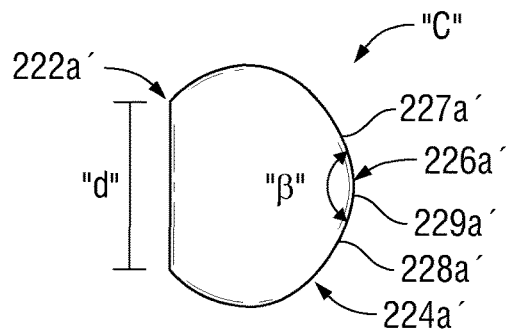

FIG. 8A

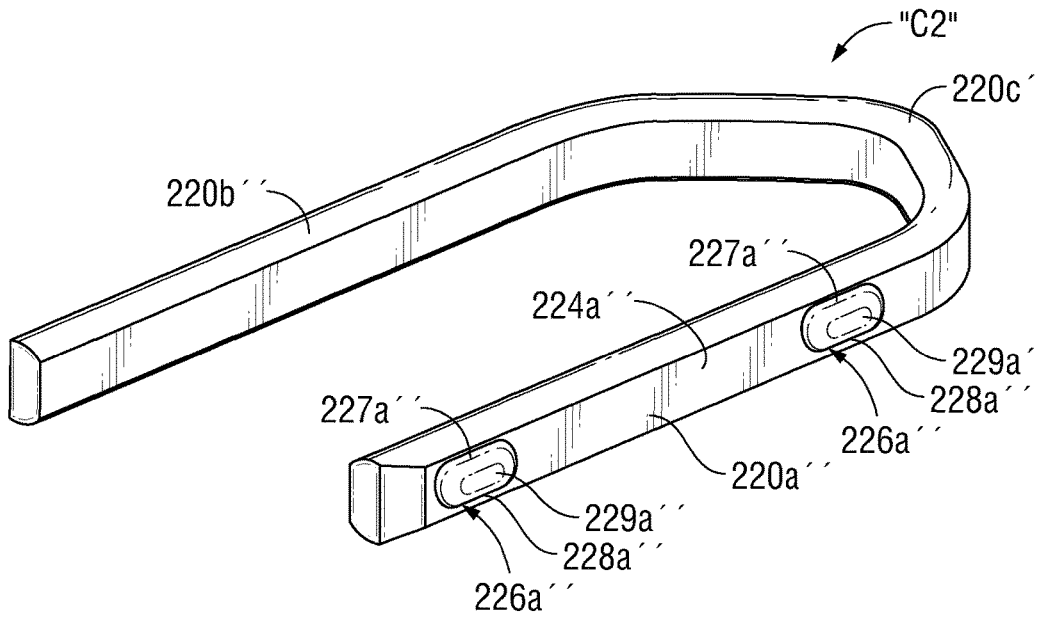

FIG. 8B

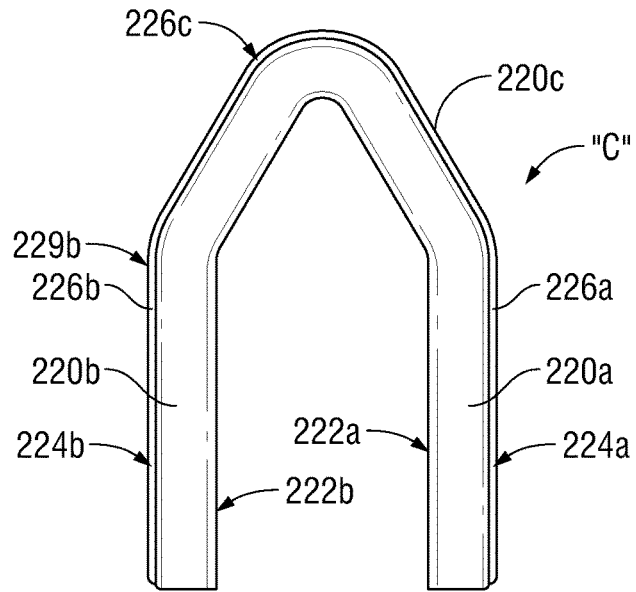

FIG. 9

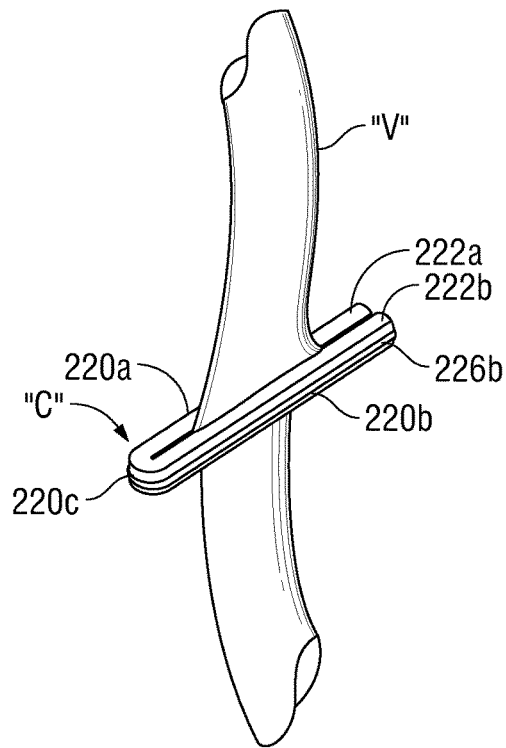

FIG. 10

SELF-CENTERING CLIP AND JAW**CROSS-REFERENCE TO RELATED APPLICATION**

The present application is a Divisional application which claims the benefit of and priority to U.S. patent application Ser. No. 13/196,109 entitled "Self-Centering Clip and Jaw" filed on Aug. 2, 2011, now U.S. Pat. No. 9,011,464, which claims priority to, and benefit of, U.S. Provisional Patent Application No. 61/409,131 entitled "Self-Centering Clip and Jaw" filed on Nov. 2, 2010, the entire contents of each of which are hereby incorporated by reference herein.

BACKGROUND**Technical Field**

The present disclosure relates to surgical instruments. More particularly, the present disclosure relates to an endoscopic surgical clip applier and corresponding surgical clips.

Description of Related Art

Endoscopic staplers and clip appliers are known in the art and are used for a number of distinct and useful surgical procedures. In the case of a laparoscopic surgical procedure, access to the interior of an abdomen is achieved through narrow tubes or cannulas inserted through a small entrance incision in the skin. Minimally invasive procedures performed elsewhere in the body are often generally referred to as endoscopic procedures. Typically, a tube or cannula device is extended into the patient's body through the entrance incision to provide an access port. The port allows the surgeon to insert a number of different surgical instruments therethrough using a trocar and for performing surgical procedures far removed from the incision.

During a majority of these procedures, the surgeon must often terminate the flow of blood or another fluid through one or more vessels. The surgeon will often apply a surgical clip to a blood vessel or another duct to prevent the flow of body fluids therethrough during the procedure. An endoscopic clip applier is known in the art for applying a single clip or a series of clips during a surgical procedure. Such clips are typically fabricated from a biocompatible material and are usually compressed over a vessel. Once applied to the vessel, the compressed clip terminates the flow of fluid therethrough.

Endoscopic clip appliers that are able to apply multiple clips in endoscopic or laparoscopic procedures during a single entry into the body cavity are described in commonly-assigned U.S. Pat. Nos. 5,084,057 and 5,100,420 to Green et al., which are both incorporated by reference in their entirety. Another multiple endoscopic clip applier is disclosed in commonly-assigned U.S. Pat. No. 5,607,436 by Pratt et al., the contents of which is also hereby incorporated by reference herein in its entirety. These devices are typically, though not necessarily, used during a single surgical procedure. U.S. patent application Ser. No. 08/515,341 now U.S. Pat. No. 5,695,502 to Pier et al., the disclosure of which is hereby incorporated by reference herein, discloses a resterilizable surgical clip applier. The clip applier advances and forms multiple clips during a single insertion into the body cavity. This resterilizable clip applier is configured to receive and cooperate with an interchangeable clip magazine so as to advance and form multiple clips during a single entry into a body cavity.

One significant design goal in the manufacture of clip appliers is to align the surgical clips between the jaws and maintain the alignment of the legs of the clip throughout a

formation of the clip onto the body tissue or vessel. It is therefore desirable to provide a surgical clip and surgical clip applier that promote proper alignment of the legs of the clip within the jaws thereof and throughout the formation of the clip onto the body tissue or vessel.

SUMMARY

In accordance with the present disclosure, an apparatus for application of surgical clips to body tissue is provided. The apparatus includes a handle assembly having a handle and a trigger moveable with respect to the handle. An elongated shaft extends distally from the handle assembly and includes one or more surgical clips disposed therein. Each surgical clip includes a pair of legs connected to each other at one end by a crossbar. Each of the pair of legs has an inwardly facing surface and an outwardly facing surface. The outwardly facing surface of each leg has a raised profile protruding therefrom and extending longitudinally therealong. A jaw assembly is disposed at a distal end of the elongated shaft and includes first and second opposed jaws moveable between a spaced apart position and an approximated position. Each of the jaws defines a recess extending longitudinally along opposing inner surfaces thereof. Each of the recesses defines a longitudinally extending groove having a profile substantially complementary to the raised profile of the legs of the one or more surgical clips. The legs of each of the surgical clips are positionable at least partially within respective grooves of the recesses of the jaws.

In one embodiment, the outwardly facing surfaces of the legs of each surgical clip have a substantially triangular transverse cross-sectional profile. The groove defined in each recess of the jaws may also have a substantially triangular transverse cross-sectional profile.

In yet another embodiment, each leg of each surgical clip has a chevron transverse cross-sectional profile. The cross bar of each surgical clip may also have a chevron shaped transverse cross-sectional profile.

In still another embodiment, each groove of each jaw is defined by a first wall and a second wall angled toward each other and defining an angle therebetween. Similarly, the outwardly facing surface of each leg of each surgical clip may be defined by a first wall and a second wall angled toward each other and defining an angle therebetween. Further, the angle defined by the first wall and the second wall of the outer surface of each leg of each surgical clip may be smaller than the angle defined by the first wall and the second wall of the groove of the jaws.

In still yet another embodiment, a shoulder is defined at an interface between the recess and the groove of each jaw at opposed sides of the groove.

In accordance with another embodiment of the present disclosure, a jaw assembly for use in a surgical clip applier configured to apply surgical clips to body tissue is provided. Each of the surgical clips includes a pair of opposed legs, each having an outwardly projecting longitudinally extending raised profile. The jaw assembly includes first and second opposed jaws moveable between a spaced apart position and an approximated position. Each of the jaws defines a recess extending longitudinally along opposing inner surfaces thereof. Each of the recesses defines a longitudinally extending groove and each of the jaws is configured for positioning of a leg of a surgical clip at least partially within the recess of the jaw and for receiving the raised portion of each leg of the surgical clip in a groove of a respective jaw.

3

In one embodiment, the jaw assembly includes a shoulder defined at an interface between the recess and the groove of each jaw at opposed sides of the groove. Further, the groove defined in the recess of each jaw may have a substantially triangular transverse cross-sectional profile or a chevron transverse cross-sectional profile.

In accordance with another embodiment of the present disclosure, each surgical clip includes a pair of legs connected to each other at one end by a crossbar. Each leg includes an inwardly facing surface and an outwardly facing surface. The outwardly facing surface of each leg includes a plurality of spaced-apart protrusions formed thereon, each protrusion defining a raised profile protruding from the outwardly facing surface of the leg thereof. This surgical clip may be used in conjunction with any of the jaw assemblies described above.

BRIEF DESCRIPTION OF THE DRAWINGS

Various embodiments of the subject instrument are described herein with reference to the drawings wherein:

FIG. 1 is a perspective view of a surgical clip applicator;

FIG. 2 is a further perspective view of the surgical clip applicator of FIG. 1, illustrating a rotation of an elongate tubular member thereof;

FIG. 3 is an enlarged, perspective view of the jaw structure of the surgical clip applicator of FIGS. 1 and 2;

FIG. 4 is a front, perspective view of a jaw assembly for use in the surgical clip applicator of FIG. 1;

FIG. 5 is a distal end view of one of the jaws of the jaw assembly of FIG. 4;

FIG. 6 is a front, perspective view of the jaw of FIG. 5 shown having a portion of a surgical clip supported therein;

FIG. 7 is a front, perspective view of a surgical clip for use in the surgical clip applicator of FIG. 1;

FIG. 8 is a transverse, cross-sectional view of one leg of the surgical clip of FIG. 7;

FIG. 8A is a transverse, cross-sectional view of one leg of a surgical clip according to another embodiment of the present disclosure;

FIG. 8B is a front, perspective view of another embodiment of a surgical clip according to the present disclosure;

FIG. 9 is a top, plan view of the surgical clip of FIG. 7; and

FIG. 10 is a perspective view of the surgical clip of FIG. 7 formed on a vessel.

DETAILED DESCRIPTION

Embodiments of a surgical clip applicator in accordance with the present disclosure will now be described in detail with reference to the drawing figures wherein like reference numerals identify similar or identical structural elements. As shown in the drawings and described throughout the following description, as is traditional when referring to relative positioning on a surgical instrument, the term "proximal" refers to the end of the apparatus which is closer to the user and the term "distal" refers to the end of the apparatus which is further away from the user.

Referring briefly to FIGS. 1-3, a surgical clip applicator in accordance with the present disclosure is generally designated as 100. Surgical clip applicator 100 generally includes a handle assembly 102 and an endoscopic portion including a shaft assembly 104 extending distally from handle assembly 102 and having a jaw assembly 120 disposed at a distal end thereof. A stack of surgical clips is typically loaded and/or retained within shaft assembly 104 in a manner so as to slide

4

therewithin and/or therealong. A complete description of the inner-workings and operation of surgical clip applicator 100 can be found in commonly-assigned U.S. patent application Ser. No. 12/055,446 to Whitfield et. al., the entire contents of which are hereby incorporated by reference herein.

With continued reference to FIGS. 1-3, jaw assembly 120 is mounted in the distal end of shaft assembly 104 such that jaws 120a, 120b are longitudinally stationary relative thereto. A knob 110 may be rotatably mounted on a distal end of handle assembly 102 and affixed to shaft assembly 104 to transmit and/or provide 360° rotation to shaft assembly 104 and jaws 120a, 120b about a longitudinal axis "x" thereof. As will be described in greater detail hereinbelow, jaws 120a and 120b of jaw assembly 120 each define a recess 122a, 122b within an inwardly facing surface thereof as well as a groove 124a, 124b defined within the respective recesses 122a, 122b. The recesses 122a and 122b and the grooves 124a and 124b are configured for guiding passage of a surgical clip (see FIGS. 6-10) therethrough.

Referring now to FIGS. 4-6, jaws 120a, 120b are shown each having a respective recess 122a, 122b extending longitudinally therealong. More specifically, recesses 122a and 122b are defined within inwardly facing surfaces 121a and 121b of jaws 120a and 120b, respectively. Recesses 122a and 122b each define a width "w" (FIG. 5) and may have a generally rectangular transverse cross-sectional profile. As can be appreciated, width "w" is sufficiently large to allow passage therethrough of a clip "C" (FIG. 6). In other words, the width "w" is larger than a diameter "d" of clip "C" (FIG. 8) such that clip "C" is positionable at least partially within and slidable through recesses 122a and 122b of jaws 120a and 120b, respectively. Recesses 122a, 122b may be formed within jaws 120a, 120b, respectively, via machining, or any other suitable process.

With continued reference to FIGS. 4-6, grooves 124a and 124b are defined within recesses 122a and 122b of jaws 120a and 120b, respectively. Similar to recesses 122a and 122b, grooves 124a and 124b extend longitudinally along jaw members 120a and 120b, respectively. The width "w" of recess 122a of jaw 120a is larger than a maximum diameter of groove 124a such that a pair of shoulders 125a is defined at the interfaces between recess 122a groove 124a. Similarly to jaw 120a, the width of recess 122b of jaw 120b is larger than a maximum diameter of groove 124b such that a pair of shoulders is defined at the interfaces between recess 122b groove 124b.

Grooves 124a and 124b are defined by first walls 126a, 127a and second walls 126b, 127b, respectively. Each pair of walls 126a, 127a and 126b, 127b extend toward each other at an angle "α," eventually converging to a nadir 128a and 128b of grooves 124a and 124b, respectively. Thus, grooves 124a and 124b define a substantially triangular, or V-shaped transverse cross-sectional profile, as best shown in FIGS. 4-6. It is also envisioned that first and second walls 126a, 126b and 127a, 127b may be non-linear, e.g., curved or bowed, as shown in FIGS. 5-6, to thereby define a chevron transverse cross-sectional profile. Additionally, grooves 124a, 124b and/or recesses 122a, 122b may be centered with respect to a height of jaws 120a and 120b, respectively, or with respect to width "w" of recesses 122a, 122b. Further, grooves 124a and 124b may be centered with respect to recesses 120a and 120b defined within jaws 120a and 120b, respectively.

Referring now to FIGS. 7-9, each clip "C" includes a pair of legs 220a, 220b interconnected by a crown, backspan, or crossbar 220c. An inwardly facing surface 222a, 222b of each leg 220a and 220b, respectively, defines a generally flat

5

geometry such that upon forming of clip "C" about a body tissue or vessel, inwardly facing surfaces **222a** and **222b** of legs **220a** and **220b** consistently and evenly clamp around the body tissue or vessel. Outwardly facing surfaces **224a** and **224b** of legs **220a** and **220b**, respectively, may define a generally circular transverse cross-sectional profile and may include raised profiles **226a** and **226b** protruding from respective outwardly facing surfaces **224a** and **224b** and extending longitudinally therealong. Crossbar **220c** may similarly include a raised profile **226c** protruding therefrom and interconnecting raised profile **226a** of leg **220a** with raised profile **226b** of leg **220b** to form an uninterrupted raised profile substantially along the entire outwardly facing surface of clip "C."

More particularly, as seen in FIG. 8, raised profile **226a** is defined by first and second walls **227a** and **228a**, respectively, extending outwardly from outwardly facing surface **224a** of leg **220a**. First and second walls **227a** and **228a**, respectively, are angled toward each other at an angle " β " to a peak **229a** to define a substantially triangular, V-shaped or chevron transverse cross-sectional profile. Similarly to leg **220a**, raised profile **226b** of leg **220b** is defined by first and second walls extending outwardly from an outwardly facing surface of leg **220b**. The first and second walls are also angled toward each other at an angle " β ," to a peak.

It is envisioned that angle " β ," the angle defined by walls **227a** and **228a** of raised profile **226a**, and similarly defined by the first and second walls of raised profile **226b**, is about equal to or less than the angle " α " defined between the first and second walls **126a**, **126b** and **127a**, **127b** of grooves **124a** and **124b** of jaws **120a** and **120b**, respectively, such that raised profile **226a** is at least partially positionable within groove **124a** of jaw **120a** and such that raised profile **226b** is at least partially positionable within groove **124b** of jaw **120b**.

Further, it is envisioned that first and second walls **227a** and **228a** of leg **220a** and the first and second walls of leg **220b** be non-linear, e.g., curved or bowed. Additionally, the non-linear shape of the first and second walls of legs **220a**, **220b** may be shaped similarly to non-linear walls **126a**, **126b**, **127a** and **127b** of grooves **124a** and **124b** of jaws **120a** and **120b**, respectively. Accordingly, where angle " α " is equal to angle " β ," raised profiles **226a** and **226b** are thus shaped complementary to grooves **124a** and **124b**, respectively. However, it is also contemplated that where angles " α " and " β " are different, e.g., where " α " is greater than " β ," raised profiles **226a** and **226b** are shaped substantially, or quasi-complementarily to grooves **124a** and **124b**, respectively.

Turning now to FIG. 8A, an outer profile for an alternate clip "C1" is illustrated. As seen in FIG. 8A, an outwardly facing surface **224a'** of a leg **220a'** of clip "C1" includes substantially planar first and second walls **227a'** and **228a'** that are angled toward each other, by angle " β ", to a peak **229a'** to define a substantially triangular shaped, V-shaped or chevron shaped transverse cross-sectional profile **226a'**.

Referring to FIG. 8B, another embodiment of a clip "C2" configured for use with surgical clip applicator **100** (FIGS. 1-3) includes a pair of legs **220a"**, **220b"** interconnected by a crossbar **220c"**. Clip "C2" is similar to clip "C" (FIGS. 7, 8 and 9) and may include any of the features associated with clip "C" described above. However, different from clip "C" (FIGS. 7, 9 and 9), clip "C2" includes a plurality of discrete, spaced-apart, raised protrusions **226a"** protruding from outwardly facing surface **224a"** of leg **220a"**. Clip "C2" may also include protrusions (not explicitly shown) extending

6

similarly from the outwardly facing surface of leg **220b"** and/or from the outwardly facing surface of crossbar **220c"**. The protrusions, e.g., protrusions **226a"**, may be formed via coining, or any other suitable manufacturing process.

With continued reference to FIG. 8B, each protrusion **226a"** includes a pair of opposed angled surfaces **227a"**, **228a"** that are angled toward each other, defining an angle " β " (see FIG. 8) therebetween, and ultimately converging to define a peak **229a"**. In other words, angled surfaces **227a"**, **228a"** and peak **229a"** cooperate to define a substantially triangular, V-shaped or chevron transverse cross-sectional profile. Further, although two protrusions **226a"** are shown, it is envisioned that greater or fewer than two protrusions **226a"** be provided and/or that protrusions **226a"** be spaced further-apart or closer-together relative to one another. Clip "C2" may otherwise be configured similarly to clip "C" (FIGS. 7, 8 and 9) or clip "C1" (FIG. 8A), discussed above.

The operation of surgical clip applicator **100**, to crimp or form a surgical clip "C" around a target body tissue, such as, for example, a vessel (FIG. 10), will now be described with reference to FIGS. 1-10.

Initially, clip applicator **100** is positioned such that a tissue or a vessel "V" to be clamped is disposed between jaws **120a** and **120b**. As trigger **108** is squeezed or actuated, trigger **108** causes clip "C" to translate distally into recesses **122a** and **122b** of jaws **120a** and **120b**, respectively, such that at least a portion of leg **220a** is positioned within recess **122a** of jaw member **120a** and such that at least a portion of leg **220b** is positioned within recess **122b** of jaw member **120b**. Thus, legs **220a** and **220b** of clip "C," similar to jaws **120a** and **120b**, are now also positioned surrounding tissue or vessel "V" to be clamped.

In this position, the raised profiles **226a** and **226b** protruding from legs **220a** and **220b**, respectively, are positioned within grooves **124a** and **124b** of jaws **120a** and **120b**, respectively. This configuration ensures proper alignment of legs **220a** and **220b** of clip "C" relative to one another and, in turn, clip "C" within jaws **120a**, **120b**, respectively. In other words, recesses **122a** and **122b**, in cooperation with grooves **124a** and **124b** serve as a "track" to permit longitudinal translation of legs **220a** and **220b** of clip "C" therethrough, but substantially inhibit rotational, vertical and/or transverse movement and/or canting of legs **220a** and **220b** of clip "C" relative to one another, thereby helping to ensure proper alignment of clip "C" within jaws **120**.

At this point, legs **220a** and **220b** of clip "C" are positioned within recesses **122a**, **122b**, with raised profiles **226a** and **226b** positioned within grooves **124a**, **124b** of jaws **120a**, **120b**, respectively. As shown in FIGS. 7-9, clip "C" initially defines an unformed configuration in which legs **220a** and **220b** are spaced apart relative to one another. As trigger **108** is squeezed further, jaws **120a** and **120b** are moved from the open position toward the approximated position, thereby beginning to form surgical clip "C" interposed therebetween. As seen in FIG. 10, surgical clip "C" may be formed or crimped onto a vessel "V" or any other biological tissue. During formation of clip "C," the flat, inwardly facing surfaces **222a** and **222b** of legs **220a** and **220b**, are approximated toward each other to thereby effect clamping of vessel "V." Alternatively, inwardly facing surfaces **222a**, **222b** may include one or more features to promote a secure and effective clamp about tissue or vessel "V."

During formation of clip "C," the complementary shaped raised profiles **226a** and **226b** of legs **220a** and **220b** of clip "C" are retained within grooves **124a** and **124b** of jaws **10a**,

120b and, more specifically, legs 220a and 220b of clip "C" are retained with recesses 122a and 122b of jaws 120a, 120b, such that rotational, vertical and/or transverse movement of clip "C" relative to jaw assembly 120 is substantially inhibited. Accordingly, as jaws 120a and 120b are moved together to form clip "C," legs 220a and 220b are similarly brought together, in a substantially aligned coplanar orientation, to clamp about vessel "V." In other words, the recesses 122 and grooves 124 of the jaws 120a, 120b and corresponding configuration of clip "C", including raised profiles 226 thereof, reduce incidents and/or prevent scissoring of legs 220a and 220 during formation of clip "C." Increasing incidents of proper alignment of legs 220a and 220b helps in the proper formation of clips "C."

Once clip "C" has been clamped about vessel "V," as shown in FIG. 10, trigger 108 may be released, allowing jaw assembly 120 to return back to the spaced apart position. The above-described operation of surgical clip applier 100 may then be repeated for subsequent clamping of clips "C" about tissue.

In accordance with the present disclosure, in an embodiment, by providing grooves 124a, 124b in the jaws that interact and cooperate with raised profiles 226c of the clips, the width "w" of recesses 122a and 122b may be sufficiently large, relative to a maximum width of the legs of the clip, to accommodate variations in manufacturing tolerances with respect to a width dimension of the legs of the clips, with respect to a linearity of the legs of the clips, with respect to a width dimension of the recesses of the jaws, and with regard to a linearity of the recesses of the jaws.

It should be understood that the foregoing description is only illustrative of the present disclosure. Various alternatives and modifications can be devised by those skilled in the art without departing from the disclosure. Accordingly, the present disclosure is intended to embrace all such alternatives, modifications and variances. The embodiments described with reference to the attached drawing figures are presented only to demonstrate certain examples of the disclosure. Other elements, steps, methods and techniques that are insubstantially different from those described above and/or in the appended claims are also intended to be within the scope of the disclosure.

What is claimed is:

1. An apparatus for application of surgical clips to body tissue, the apparatus comprising:

a handle assembly having a handle and a trigger moveable with respect to the handle;

an elongated shaft extending distally from the handle assembly, the elongated shaft including at least one surgical clip disposed therein, each surgical clip including a pair of legs connected to each other at one end by a crossbar, each of the pair of legs having an inwardly facing surface, an outwardly facing surface, and defining a length, the outwardly facing surface including a plurality of spaced-apart protrusions formed thereon and extending the length thereof, each protrusion defining a raised profile protruding from the outwardly facing surface of the leg, wherein each of the plurality of protrusions is defined by at least one wall; and

a jaw assembly disposed at a distal end of the elongated shaft, the jaw assembly including first and second opposed jaws moveable between a spaced apart position and an approximated position, each of the jaws defining a recess extending longitudinally along opposing inner surfaces thereof, each of the recesses defining a longitudinally extending groove having a profile substantially complementary to the raised profile of the

protrusions of the legs of the at least one surgical clip, wherein the groove of each jaw is defined by at least one wall;

wherein the at least one surgical clip is configured to longitudinally slide from the elongated shaft into the jaw assembly such that the legs of the at least one surgical clip are positioned at least partially within and slid along respective grooves of the recesses of the jaws and such that the plurality of spaced-apart protrusions of each leg are positioned at least partially within the groove of the recess of the respective jaw and slid therealong with the least one wall of each of the plurality of protrusions sliding along the at least one wall of the groove of the recess of the respective jaw.

2. The apparatus according to claim 1, wherein the protrusions each have a substantially triangular transverse cross-sectional profile.

3. The apparatus according to claim 1, wherein the groove defined in each recess of the jaws has a substantially triangular transverse cross-sectional profile.

4. The apparatus according to claim 1, wherein each protrusion has a chevron transverse cross-sectional profile.

5. The apparatus according to claim 1, wherein the groove of each jaw is defined by a first wall and a second wall angled toward each other and defining an angle therebetween.

6. The apparatus according to claim 5, wherein each protrusion is defined by a first wall and a second wall angled toward each other and defining an angle therebetween.

7. The apparatus according to claim 6, wherein the angle defined by the first wall and the second wall of each protrusion is smaller than the angle defined by the first wall and the second wall of the groove of each jaw.

8. The apparatus according to claim 1, wherein a shoulder is defined at an interface between the recess and the groove of each jaw at opposed sides of the groove.

9. The apparatus according to claim 1, wherein the plurality of spaced-apart protrusions of each leg of each surgical clip includes a first protrusion adjacent a free end of the respective leg and a second protrusion adjacent the crossbar of the respective surgical clip.

10. The apparatus according to claim 9, wherein the first protrusion of each leg is positionable at least partially within the groove of the recess of the respective jaw towards a distal end thereof, and wherein the second protrusion of each leg is positionable at least partially within the groove of the recess of the respective jaw towards a proximal end thereof.

11. An apparatus for application of surgical clips to body tissue, the apparatus comprising:

a jaw assembly including first and second opposed jaws moveable between a spaced apart position and an approximated position, each of the jaws defining a recess extending longitudinally along opposing inner surfaces thereof, each of the recesses defining a longitudinally extending groove, wherein each groove of each jaw is defined by a first wall and a second wall angled toward each other and defining an angle therebetween; and

at least one surgical clip, each surgical clip including a pair of legs connected to each other at one end by a crossbar, each of the pair of legs having an inwardly facing surface and an outwardly facing surface, the outwardly facing surface including a plurality of spaced-apart protrusions formed thereon, each protrusion defining a raised profile protruding from the outwardly facing surface of the leg, wherein each protrusion is defined by first and second longitudinally-

9

extending walls angled toward each other and defining an angle therebetween, wherein the angle defined by the walls of each protrusion is smaller than the angle defined by the walls of the groove of each jaw, wherein the at least one surgical clip is longitudinally slidable relative to the jaw assembly such that the legs of the at least one surgical clip are slid at least partially within respective grooves of the recesses of the jaws and such that the plurality of spaced-apart protrusions of each leg are positioned at least partially within the groove of the recess of the respective jaw and slid therealong with the first and second walls of each of the plurality of spaced-apart protrusions of each leg sliding along the respective first and second walls of the groove of the recess of the respective jaw.

12. The apparatus according to claim 11, wherein the protrusions each have a substantially triangular transverse cross-sectional profile.

13. The apparatus according to claim 11, wherein the groove defined in each recess of the jaws has a substantially triangular transverse cross-sectional profile.

14. The apparatus according to claim 11, wherein each protrusion has a chevron transverse cross-sectional profile.

10

15. The apparatus according to claim 11, wherein a shoulder is defined at an interface between the recess and the groove of each jaw at opposed sides of the groove.

16. The apparatus according to claim 11, further including:
 a handle assembly having a handle and a trigger moveable with respect to the handle; and
 an elongated shaft extending distally from the handle assembly, the elongated shaft including the at least one surgical clip disposed therein, wherein the jaw assembly is disposed at a distal end of the elongated shaft.

17. The apparatus according to claim 11, wherein the plurality of spaced-apart protrusions of each leg of each surgical clip includes a first protrusion adjacent a free end of the respective leg and a second protrusion adjacent the crossbar of the respective surgical clip.

18. The apparatus according to claim 17, wherein the first protrusion of each leg is positionable at least partially within the groove of the recess of the respective jaw towards a distal end thereof, and wherein the second protrusion of each leg is positionable at least partially within the groove of the recess of the respective jaw towards a proximal end thereof.

* * * * *