



- (51) International Patent Classification:  
E21B 47/12 (2012.01)
- (21) International Application Number:  
PCT/US2013/076285
- (22) International Filing Date:  
18 December 2013 (18.12.2013)
- (25) Filing Language: English
- (26) Publication Language: English
- (30) Priority Data:  
61/739,677 19 December 2012 (19.12.2012) US  
61/862,403 5 August 2013 (05.08.2013) US
- (71) Applicant (for all designated States except US): **EXXON-MOBIL UPSTREAM RESEARCH COMPANY** [US/US]; Corp-urc-sw359, P.O. Box 2189, Houston, TX 77252-2189 (US).
- (72) Inventors; and
- (71) Applicants (for US only): **KELLER, Stuart, R.** [US/US]; 5123 Indigo St., Houston, TX 77096 (US). **MORROW, Timothy, I.** [US/US]; 9806 Moonscape View, Humble, TX 77396 (US). **BURNS, James, S.** [US/US]; 2122 Ridge

Wood Ln, Sugar Land, TX 77479 (US). **DEFFEN-BAUGH, Max** [US/US]; 401 County Road 513, Califon, NJ 07830 (US). **DISKO, Mark, M.** [US/US]; 612 Woodglen Rd., Glen Gardner, NJ 08826 (US). **STILES, David, A.** [US/US]; 5517 Venice St., Houston, TX 77007 (US).

(74) Agents: **JAMES, Rick, F.** et al.; Exxonmobil Upstream Research Company, Corp-urc-sw359, P.O. Box 2189, Houston, TX 77252-2189 (US).

(81) Designated States (unless otherwise indicated, for every kind of national protection available): AE, AG, AL, AM, AO, AT, AU, AZ, BA, BB, BG, BH, BN, BR, BW, BY, BZ, CA, CH, CL, CN, CO, CR, CU, CZ, DE, DK, DM, DO, DZ, EC, EE, EG, ES, FI, GB, GD, GE, GH, GM, GT, HN, HR, HU, ID, IL, IN, IR, IS, JP, KE, KG, KN, KP, KR, KZ, LA, LC, LK, LR, LS, LT, LU, LY, MA, MD, ME, MG, MK, MN, MW, MX, MY, MZ, NA, NG, NI, NO, NZ, OM, PA, PE, PG, PH, PL, PT, QA, RO, RS, RU, RW, SA, SC, SD, SE, SG, SK, SL, SM, ST, SV, SY, TH, TJ, TM, TN, TR, TT, TZ, UA, UG, US, UZ, VC, VN, ZA, ZM, ZW.

[Continued on next page]

(54) Title: WIRED AND WIRELESS DOWNHOLE TELEMETRY USING A LOGGING TOOL

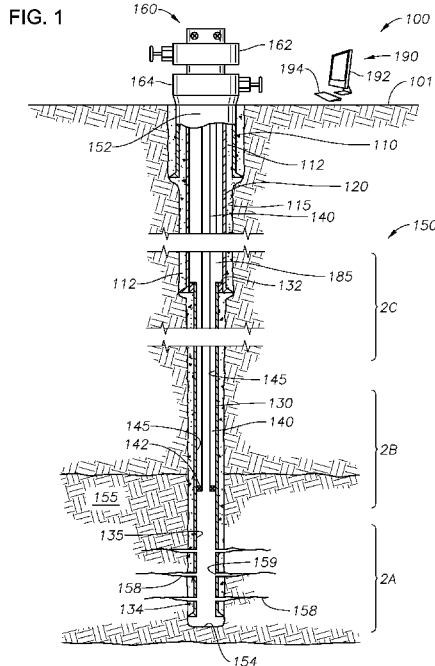

(57) Abstract: A system for downhole telemetry is provided herein. The system employs a series of communications nodes spaced along a tubular body in a wellbore. Each communications node is associated with a sensor that senses data indicative of a formation condition or a wellbore parameter along a subsurface formation. The data is stored in memory until a logging tool is run into the wellbore. The data is transmitted from the respective communications nodes to a receiver in the logging tool. The data is then transferred to the surface. A method of transmitting data in a wellbore is also provided herein. The method uses a logging tool to harvest data in a wellbore from a plurality of sensor communications nodes.

WO 2014/100275 A1

- (84) Designated States** (*unless otherwise indicated, for every kind of regional protection available*): ARIPO (BW, GH, GM, KE, LR, LS, MW, MZ, NA, RW, SD, SL, SZ, TZ, UG, ZM, ZW), Eurasian (AM, AZ, BY, KG, KZ, RU, TJ, TM), European (AL, AT, BE, BG, CH, CY, CZ, DE, DK, EE, ES, FI, FR, GB, GR, HR, HU, IE, IS, IT, LT, LU, LV, MC, MK, MT, NL, NO, PL, PT, RO, RS, SE, SI, SK, SM, TR), OAPI (BF, BJ, CF, CG, CI, CM, GA, GN, GQ, GW, KM, ML, MR, NE, SN, TD, TG).
- *as to the applicant's entitlement to claim the priority of the earlier application (Rule 4.17(iii))*
- Published:**
- *with international search report (Art. 21(3))*
- *before the expiration of the time limit for amending the claims and to be republished in the event of receipt of amendments (Rule 48.2(h))*

**Declarations under Rule 4.17:**

- *as to applicant's entitlement to apply for and be granted a patent (Rule 4.17(ii))*

Attorney Docket No. 2013EM219

## WIRED AND WIRELESS DOWNHOLE TELEMETRY USING A LOGGING TOOL

### CROSS-REFEREENCE TO RELATED APPLICATIONS

[0001] This application claims benefit of U.S. Provisional Patent Application No. 61/739,677, filed December 19, 2012, and U.S. Provisional Patent Application No. 61/862,403, filed August 5, 2013, both are incorporated by reference herein in their entirety.

### BACKGROUND OF THE INVENTION

[0002] This section is intended to introduce various aspects of the art, which may be associated with exemplary embodiments of the present disclosure. This discussion is believed to assist in providing a framework to facilitate a better understanding of particular aspects of the present disclosure. Accordingly, it should be understood that this section should be read in this light, and not necessarily as admissions of prior art.

#### Field of the Invention

[0003] The present invention relates to the field of data transmission. More specifically, the invention relates to the transmission of data along pipes within a wellbore. The present invention further relates to the capturing of wireless data in a wellbore from novel downhole communications nodes using a logging tool.

#### General Discussion of Technology

[0004] In the drilling of oil and gas wells, a wellbore is formed using a drill bit that is urged downwardly at a lower end of a drill string. After drilling to a predetermined depth, the drill string and bit are removed and the wellbore is lined with a string of casing. An annular area is thus formed between the string of casing and the surrounding formations. A cementing operation is typically conducted in order to fill the annular area with cement. The combination of cement and casing strengthens the wellbore and facilitates the isolation of formations behind the casing.

[0005] It is common to place several strings of casing having progressively smaller outer diameters into the wellbore. The process of drilling and then cementing progressively smaller strings of casing is repeated several times until the well has reached total depth. The final string of casing, referred to as a production casing, is cemented in place. This is a tubular body that resides adjacent one or more producing reservoirs, or "pay zones." The production casing is frequently in the form of a liner, that is, a tubular body that is not tied to the surface, but is hung from a next lowest string of casing using a liner hanger. In either instance, the production casing is perforated to provide fluid communication between the reservoir and the production tubing.

**Attorney Docket No. 2013EM219**

[0006] In some instances, the wellbore is left uncased along the pay zones. This means that no liner string is used. This is known as an open hole completion. To support the open wellbore and to prevent the migration of sand and fines into the wellbore, a filtering screen is typically placed along the subsurface reservoirs. A column of sand may also be installed around the filtering screen, thereby forming a gravel pack.

[0007] In order to move production fluids to the surface, a string of tubing is run into the casing. A packer is set proximate a lower end of the tubing to seal an annular area formed between the tubing and the surrounding strings of casing. The tubing then becomes a string of production pipe through which hydrocarbon fluids may be lifted from the pay zones.

[0008] As part of the completion process, a wellhead is installed at the surface. The wellhead controls the flow of production fluids to the surface, or the injection of fluids into the wellbore. Fluid gathering and processing equipment such as pipes, valves and separators are also provided. Production operations may then commence.

[0009] It is desirable to obtain data from the wellbore after completion. In the oil and gas industry, cables and wires are routinely run into wells for observation and analysis. These may include slick lines or wire lines for formation logging operations. Such may also include the use of fixed cables for gathering data from downhole sensors.

[0010] Various wireless technologies have also been proposed or developed for downhole communications. Such technologies are referred to in the industry as telemetry.

[0011] One example of telemetry is mud pressure pulse transmission, or so-called mud pulse telemetry. Mud pulse telemetry is commonly used during drilling to obtain real time data from sensors at or near the drill bit. Mud pulse telemetry employs variations in pressure in the drilling mud to transmit signals from a bottom hole assembly up to the surface. The variations in pressure caused by mechanical pulses may be sensed and analyzed by a computer at the surface.

[0012] Another example of downhole telemetry involves the use of acoustic energy. Acoustic telemetry employs an acoustic signal generated at or near the bottom of a well, such as from a bottom hole assembly during drilling. The signal is transmitted through steel pipe in the wellbore, meaning that the pipe serves as the carrier medium for sound waves. Transmitted sound waves are detected and converted to electrical signals at the surface for analysis.

[0013] U.S. Patent No. 5,924,499 entitled "Acoustic Data Link and Formation Property Sensor for Downhole MWD System," teaches the use of acoustic signals for "short hopping" a component along a drill string. Signals are transmitted from a drill bit or from a near-bit sub and across the mud motors. This may be done by sending separate acoustic signals

**Attorney Docket No. 2013EM219**

simultaneously -- one that is sent through the drill string, a second that is sent through the drilling mud, and optionally, a third that is sent through the formation. These signals are then processed to extract readable signals.

**[0014]** U.S. Patent No. 6,912,177, entitled "Transmission of Data in Boreholes," addresses the use of an acoustic transmitter that is as part of a downhole tool. Here, the transmitter is provided adjacent a downhole obstruction such as a shut-in valve along a drill stem so that a signal may be sent across the drill stem. U.S. Patent No. 6,899,178, entitled "Method and System for Wireless Communications for Downhole Applications," describes the use of a "wireless tool transceiver" that utilizes acoustic signaling. Here, an acoustic transceiver is in a dedicated tubular body that is integral with a gauge and/or sensor. This is described as part of a well completion.

**[0015]** Another telemetry system that has been suggested involves electromagnetic (EM) telemetry. EM telemetry employs electromagnetic waves, or alternating current magnetic fields, to "jump" across pipe joints. In practice, a specially-milled drill pipe is provided that has a conductor wire machined along an inner diameter. The conductor wire transmits signals to an induction coil at the end of the pipe. The induction coil, in turn, then transmits an EM signal to another induction coil, which sends that signal through the conductor wire in the next pipe. Thus, each threaded connection provides a pair of specially milled pipe ends for EM communication.

**[0016]** For example, service company National Oilwell Varco<sup>®</sup> of Houston, Texas offers a drill pipe network, referred to as IntelliServ<sup>®</sup> that uses EM telemetry. The IntelliServ<sup>®</sup> system employs drill pipe having integral wires that can transmit LWD/MWD data to the surface at speeds of up to 1 Mbps. This creates a communications system from the drill string itself. The NOV<sup>®</sup> IntelliServ<sup>®</sup> communications system uses an induction coil built into both the threaded box and pin ends of each drill pipe so that data may be transmitted across each connection. Examples of IntelliServe<sup>®</sup> patents are U.S. Patent No. 7,277,026 entitled "Downhole Component With Multiple Transmission Elements," and U.S. Patent No. 6,670,880 entitled "Downhole Data Transmission System." It is observed that the induction coils in an EM telemetry system must be precisely located in the box and pin ends of the joints of the drill string to ensure reliable data transfer.

**[0017]** Recently, the use of radiofrequency signals has been suggested. This is offered in U.S. Pat. No. 8,242,928 entitled "Reliable Downhole Data Transmission System." This patent suggests the use of electrodes placed in the pin and box ends of pipe joints. The electrodes are tuned to receive RF signals that are transmitted along the pipe joints having a conductor material placed there along, with the conductor material being protected by a special insulating coating. While high data transmission rates can be accomplished using

**Attorney Docket No. 2013EM219**

RF signals in a downhole environment, the transmission range is typically limited to a few meters. This, in turn, requires the use of numerous repeaters.

[0018] A need exists for a high speed data transmission system in a wellbore that does not require the machining of induction coils with precise grooves placed into pipe ends or the need for electrodes in the pipe ends. Further, a need exists for such a transmission system that does not require the precise alignment of induction coils or the placement of RF electrodes between pipe joints. In addition, a need exists for a hybrid wired-and-wireless transmission system that allows for the transmission of data from a formation, wherein the data may ultimately be wirelessly captured by running a logging tool into the wellbore.

**SUMMARY OF THE INVENTION**

[0019] A downhole acoustic telemetry system is first provided herein. The system employs novel communications nodes spaced along pipe joints within a wellbore. The pipe joints may be, for example, joints of casing (including a liner), joints of production tubing, or joints of sand control screen.

[0020] The system first comprises one or more downhole sensors. In one aspect, each of the one or more sensors resides along the wellbore proximate a subsurface formation. The subsurface formation preferably contains hydrocarbon fluids in commercially viable quantities. Each of the downhole sensors is configured to sense a subsurface condition, and then send a signal indicative of that subsurface condition.

[0021] In one aspect, the subsurface condition is pressure. In that instance, the sensor is a pressure sensor. In another aspect, the subsurface condition is temperature. In that instance, the sensor is a temperature sensor. Other types of sensors may be used. These include induction logs, gamma ray logs, formation density sensors, sonic velocity sensors, vibration sensors, resistivity sensors, flow meters, microphones, geophones, strain gauges, or combinations thereof.

[0022] The system also includes one or more sensor communications nodes, or two or more sensor communications nodes, or in some embodiments there may only be a sensor communications node for every other joint. The exact number and arrangement may depend upon factors such as signal strength, signal quality, and joint length. The one or more sensor communications nodes also reside along the wellbore proximate a depth of the subsurface formation. Each of the sensor communications nodes has a housing. The housing is fabricated from a steel material. In one aspect, each of the communications nodes also has a sealed bore formed within the housing.

[0023] In one embodiment, the sensor communications nodes are independently powered. Thus, an independent power source such as a battery or a fuel cell is provided

**Attorney Docket No. 2013EM219**

within the bore of those housings for providing power to the transceivers. In another aspect, particularly when the sensor communications nodes are placed along an outer diameter of production tubing, the sensor communications nodes may be powered by a wire extending from the surface.

**[0024]** Each of the one or more downhole sensors resides within the housing of a corresponding sensor communications node. Alternatively, each of the downhole sensors resides adjacent the housing of a corresponding sensor communications node.

**[0025]** In one aspect, each of the sensor communications nodes includes one, and preferably two, clamps. In this way, each of the sensor communications nodes is clamped onto an outer surface of a subsurface pipe, such as casing. The sensor communications nodes may be placed along 2, 10, or even 20 or more joints of casing or sand control screen, with one node per joint.

**[0026]** Each of the sensor communications nodes has a transmitter. The transmitter resides within the sealed bore. The transmitter transmits wireless signals indicative of the subsurface condition as reported by the downhole sensors.

**[0027]** The system also includes a logging tool. The logging tool comprises a receiver. The receiver is configured to harvest the wireless signals from the transmitters when the logging tool is run into (or retrieved back from) a wellbore.

**[0028]** The system further includes a working line. The working line is configured to run the logging tool into a wellbore proximate an end of the working line.

**[0029]** In one aspect, the logging tool further comprises a memory. The memory is configured to store the harvested data in the logging tool until the logging tool is retrieved back to the surface. In another aspect, the working line comprises an insulated electric cable or a fiber optic cable. In this instance, the harvested data is transmitted back to the surface in real time.

**[0030]** For a land-based operation, the surface is an earth surface, preferably at or near the well head. For an offshore operation, the surface may be a production platform, a drilling rig, a floating ship-shaped vessel, or an FPSO.

**[0031]** In one aspect, the wellbore is completed using a production casing that has been perforated, or using a slotted liner. In this instance, a plurality of sensor communications nodes may be connected to an inner diameter or an outer diameter of the production casing or the slotted liner. In another aspect, the wellbore is completed as an open hole. In this instance, a plurality of sensor communications nodes may be connected to an inner or outer diameter of sand control screen joints. In still another embodiment, one or more sensor

**Attorney Docket No. 2013EM219**

communications nodes are also embedded into or placed immediate along a rock matrix making up the subsurface formation.

**[0032]** The wellbore may include a production tubing. The tubing extends from the surface and down proximate the subsurface formation. In this instance, one or more sensor communications nodes may optimally be placed along an outer diameter of the production tubing.

**[0033]** The system may optionally include a wellbore cable. The wellbore cable may be used to deliver power to certain of the sensor communications nodes, particularly when sensor communications nodes reside along the production tubing.

**[0034]** In one embodiment, the downhole acoustic telemetry system also comprises a series of acoustic communications nodes. These are in addition to the sensor communications nodes. Each of the acoustic communications nodes is attached to a joint of subsurface pipe within the wellbore according to a pre-designated spacing. Further, adjacent acoustic communications nodes are configured to communicate by acoustic signals transmitted up through the joints of pipe. Preferably, the joints of pipe form a section of production casing.

**[0035]** Each of the acoustic communications nodes comprises:

a housing having a sealed bore;

an electro-acoustic transducer and associated transceiver residing within the housing configured to relay signals, with each signal representing a packet of information that comprises an identifier for the acoustic communications node originally transmitting the signal, and an acoustic waveform indicative of a subsurface condition; and

an independent power source also residing within the housing for providing power to the transceiver, and with the housing being fabricated from a material having a resonance frequency that is within the frequency band used for the acoustic signals;

**[0036]** Each of the acoustic communications nodes is configured to acoustically transmit signals originating from a sensor communications node. Those signals are then transmitted, node to node, up the wellbore, using the subsurface pipe as a carrier medium. The signals are carried up to a last acoustic communications node. The last acoustic communications node includes a transmitter that transmits signals to the receiver on the logging tool. In this arrangement, the data harvested from the last acoustic communications nodes comprises multi-plexed data generated from one or more sensor communications nodes to the acoustic communications nodes.



**Attorney Docket No. 2013EM219**

[0037] In one embodiment, at least one of the one or more sensor communications nodes resides within or is in contact with a rock matrix making up the surface formation. Alternatively, at least one of the sensor communications nodes resides along a downhole tool. The downhole tool may be, for example, a sliding sleeve or an inflow control device.

[0038] A separate method of transmitting data along a wellbore and up to a surface is also provided herein. The method uses a plurality of data transmission nodes situated along a tubular body to accomplish a wireless transmission of data along the wellbore. The wellbore penetrates into a subsurface formation, allowing for the communication of a wellbore condition at the level of the subsurface formation up to the surface.

[0039] The method first includes placing one or more downhole sensors along the wellbore. The sensors are placed proximate a depth of the subsurface formation. In one aspect, the sensors reside within the housing of a respective sensor communications node, such as the sensor communications nodes described above. Alternatively, each of the downhole sensors resides adjacent the housing of a corresponding sensor communications node.

[0040] The method also includes generating signals at the downhole sensors that are indicative of one or more subsurface conditions.

[0041] The method further includes providing one or more sensor communications nodes along the wellbore. Each sensor communications node is configured to process signals generated by a downhole sensor, and transmit those signals via a transmitter.

[0042] The method additionally includes running a logging tool into the wellbore. The logging tool is run proximate the end of a working line. The logging tool includes a receiver. The receiver is configured to harvest data from the transmitters of the sensor communications nodes.

[0043] The method also includes harvesting data from one or more of the sensor communications nodes from the transmitter. The method then includes receiving the harvested data at the surface. For a land-based operation, the surface is an earth surface, preferably at or near the well head. For an offshore operation, the surface may be a production platform, a drilling rig, a floating ship-shaped vessel, or an FPSO.

[0044] In one embodiment, receiving the harvested data comprises transmitting the harvested data from the logging tool up a communications wire in the running tool and to a processor at the surface. In this instance, the communications wire may be an insulated electrical cable or a fiber optic cable. In another embodiment, receiving the harvested data comprises storing the harvested data in memory on the logging tool, pulling the running tool

**Attorney Docket No. 2013EM219**

from the wellbore, retrieving the logging tool, and then uploading the harvested data onto a processor at the surface.

**[0045]** The one or more sensor communications nodes may reside on either an inner diameter or an outer diameter of a string of production casing. Alternatively or in addition, each of the sensor communications nodes reside on an outer diameter of a joint of production tubing. Alternatively or in addition, each of the one or more sensor communications nodes resides on either an inner diameter or an outer diameter of joints of sand control screen, such as along the base pipe of sand control screen joints.

**[0046]** In one embodiment, the method further comprises running joints of steel pipe into the wellbore. The joints of pipe are connected by threaded couplings to form a pipe string. The method then includes attaching a series of acoustic communications nodes to the joints of pipe during run-in. The acoustic communications nodes are placed according to a pre-designated spacing. Adjacent acoustic communications nodes are configured to communicate by acoustic signals transmitted through the joints of pipe. The acoustic communications nodes are constructed in accordance with the acoustic communications nodes described above. The method then includes sending acoustic signals from the acoustic communications nodes, node-to-node, to a last acoustic communications node.

**[0047]** In this arrangement, each of the acoustic communications nodes is configured to acoustically transmit signals originating from a sensor communications node. Those signals are then transmitted, node to node, up the wellbore, using the subsurface pipe as a carrier medium. The signals are carried up to a last acoustic communications node. The last acoustic communications node includes a transmitter that transmits signals to the receiver on the logging tool. The data harvested from the last acoustic communications nodes comprises multi-plexed data generated from two or more sensor communications nodes to the acoustic communications nodes. Because data is harvested from the last acoustic communications node, that last communications node may also be considered a sensor communications node.

**[0048]** In either embodiment, the method may further comprise transmitting energy from the logging tool to the sensor communications nodes to re-charge a battery within the sensor communications nodes.

**BRIEF DESCRIPTION OF THE DRAWINGS**

**[0049]** So that the present inventions can be better understood, certain drawings, charts, graphs and/or flow charts are appended hereto. It is to be noted, however, that the drawings illustrate only selected embodiments of the inventions and are therefore not to be considered

**Attorney Docket No. 2013EM219**

limiting of scope, for the inventions may admit to other equally effective embodiments and applications.

**[0050]** Figure 1 is a side, cross-sectional view of an illustrative wellbore. The wellbore has been completed as a cased hole completion. A string of production tubing is in place within the wellbore.

**[0051]** Figure 2A is an enlarged side, cross-sectional view of a portion of the wellbore of Figure 1. Here, portion 2A from the wellbore of Figure 1 is shown. Communications nodes are shown along the production casing.

**[0052]** Figure 2B is an enlarged side, cross-sectional view of a portion of the wellbore of Figure 1. Here, portion 2B from the wellbore of Figure 1 is shown. Communications nodes are shown along both the production casing and the production tubing.

**[0053]** Figure 2C is an enlarged side, cross-sectional view of a portion of the wellbore of Figure 1. Here, portion 2C from the wellbore of Figure 1 is shown. Communications nodes are shown along the production tubing.

**[0054]** Figure 3 is a side, cross-sectional view of another wellbore. The wellbore has been completed as an open-hole completion. A sand control screen is in place below the production tubing.

**[0055]** Figure 4A is an enlarged side, cross-sectional view of a portion of the wellbore of Figure 3. Here, portion 4A from the wellbore of Figure 3 is shown. Communications nodes are shown along both the production casing and the production tubing.

**[0056]** Figure 4B is an enlarged side, cross-sectional view of a portion of the wellbore of Figure 3. Here, portion 4B is shown.

**[0057]** Figure 5 is a perspective view of an illustrative pipe joint. A sensor communications node is shown exploded away from the pipe joint.

**[0058]** Figure 6A is a perspective view of a subsurface communications node as may be used in the data transmission systems of the present invention, in one embodiment.

**[0059]** Figure 6B is a cross-sectional view of the communications node of Figure 6A. The view is taken along the longitudinal axis of the node. Here, a sensor is provided within the communications node.

**[0060]** Figure 6C is another cross-sectional view of the communications node of Figure 6A, in an alternate embodiment. The view is again taken along the longitudinal axis of the node. Here, a sensor resides along the wellbore external to the communications node.

**Attorney Docket No. 2013EM219**

[0061] Figure 7 is a cross-sectional view of a modified sensor communications node. The view is taken along the longitudinal axis of the node. A sensor is provided within the communications node. In addition, the sensor communications node includes a transmitter.

[0062] Figures 8A and 8B are perspective views of a shoe as may be used on opposing ends of the communications node of Figure 6A or Figure 7, in one embodiment. In Figure 8A, the leading edge, or front, of the shoe is seen. In Figure 8B, the back of the shoe is seen.

[0063] Figure 9 is a cross-sectional view of an upper portion of a wellbore. Here, a logging tool is being run into the wellbore at the end of a working line. The logging tool is used to harvest data transmitted by sensor communications nodes within a wellbore.

[0064] Figure 10 is a perspective view of a portion of a communications node system of the present invention, in one embodiment. The illustrative communications node system utilizes a pair of clamps for connecting a communications node (such as either of the communications nodes of Figure 6A or Figure 7) onto a tubular body.

[0065] Figure 11 is a cross-sectional view of a wellbore having been completed in an alternate manner. Here, the illustrative wellbore has been completed as an open hole completion, with a horizontal portion. A series of sensor communications nodes is placed along the base pipe of a sand control screen in the open hole completion as part of a telemetry system.

[0066] Figure 12 is a flowchart demonstrating steps of a method for transmitting data in a wellbore in accordance with the present inventions, in one embodiment.

**DETAILED DESCRIPTION OF CERTAIN EMBODIMENTS****Definitions**

[0067] As used herein, the term "hydrocarbon" refers to an organic compound that includes primarily, if not exclusively, the elements hydrogen and carbon. Examples of hydrocarbons include any form of natural gas, oil, coal, and bitumen that can be used as a fuel or upgraded into a fuel.

[0068] As used herein, the term "hydrocarbon fluids" refers to a hydrocarbon or mixtures of hydrocarbons that are gases or liquids. For example, hydrocarbon fluids may include a hydrocarbon or mixtures of hydrocarbons that are gases or liquids at formation conditions, at processing conditions, or at ambient conditions. Hydrocarbon fluids may include, for example, oil, natural gas, gas condensates, coal bed methane, shale oil, shale gas, and other hydrocarbons that are in a gaseous or liquid state.

**Attorney Docket No. 2013EM219**

[0069] As used herein, the term “subsurface” refers to geologic strata occurring below the earth's surface.

[0070] As used herein, the term “sensor” includes any electrical sensing device or gauge. The sensor may be capable of monitoring or detecting pressure, temperature, fluid flow, vibration, resistivity, sound, vibrations, or other formation data.

[0071] As used herein, the term “formation” refers to any definable subsurface region. The formation may contain one or more hydrocarbon-containing layers, one or more non-hydrocarbon containing layers, an overburden, and/or an underburden of any geologic formation.

[0072] The terms “zone” or “zone of interest” refer to a portion of a subsurface formation containing hydrocarbons. The term “hydrocarbon-bearing formation” may alternatively be used.

[0073] As used herein, the term “wellbore” refers to a hole in the subsurface made by drilling or insertion of a conduit into the subsurface. A wellbore may have a substantially circular cross section, or other cross-sectional shape. As used herein, the term “well,” when referring to an opening in the formation, may be used interchangeably with the term “wellbore.”

[0074] The terms “tubular member,” “tubular body” or “subsurface pipe” refer to any pipe, such as a joint of casing, a portion of a liner, a production tubing, an injection tubing, a pup joint, underwater piping, or a base pipe in a sand control screen.

**Description of Selected Specific Embodiments**

[0075] The inventions are described herein in connection with certain specific embodiments. However, to the extent that the following detailed description is specific to a particular embodiment or a particular use, such is intended to be illustrative only and is not to be construed as limiting the scope of the inventions.

[0076] **Figure 1** is a side, cross-sectional view of an illustrative well site **100**. The well site **100** includes a wellbore **150** that penetrates into a subsurface formation **155**. The wellbore **150** has been completed as a cased-hole completion for producing hydrocarbon fluids.

[0077] The well site **100** includes a well head **160**. The well head **160** is positioned at an earth surface **101** over the wellbore **150**. The well head **160** controls and directs the flow of formation fluids from the subsurface formation **155** to the surface **101**.

[0078] The well head **160** may be any arrangement of pipes or valves that receives reservoir fluids at the top of the well. In the arrangement of **Figure 1**, the well head **160** is a

**Attorney Docket No. 2013EM219**

so-called Christmas tree. A Christmas tree is typically used when the subsurface formation **155** has enough *in situ* pressure to drive production fluids from the formation **155**, up the wellbore **150**, and to the surface **101**. The illustrative well head **160** includes a top valve **162** and a bottom valve **164**. In some contexts, these valves are referred to as “master valves.”

[0079] It is understood that rather than using a Christmas tree, the well head **160** may alternatively include a motor (or prime mover) at the surface **101** that drives a pump. The pump, in turn, reciprocates a set of sucker rods and a connected positive displacement pump (not shown) downhole. The pump may be, for example, a rocking beam unit or a hydraulic piston pumping unit. Alternatively still, the well head **160** may be configured to support a string of production tubing having a downhole electric submersible pump, a gas lift valve, or other means of artificial lift (not shown). The present inventions are not limited by the configuration of pumping equipment unless expressly noted in the claims.

[0080] Referring now to the wellbore **150**, the wellbore **150** has been completed with a series of pipe strings, referred to as casing. First, a string of surface casing **110** has been cemented into the formation. Cement is shown in an annular space **115** within the wellbore **150** surrounding the casing **110**. The surface casing **110** has an upper end **152** in sealed connection with the lower valve **164**.

[0081] Next, at least one intermediate string of casing **120** is cemented into the wellbore **150**. The intermediate string of casing **120** is in sealed fluid communication with the upper master valve **162**. Cement is again shown in an annular space **115** of the wellbore **150**. The combination of the casing strings **110**, **120** and the cement sheath in the annulus **115** strengthens the wellbore **150** and facilitates the isolation of formations behind the casing **110**, **120**.

[0082] It is understood that a wellbore **150** may, and typically will, include more than one string of intermediate casing. Some of the intermediate casing strings may be only partially cemented into place, depending on regulatory requirements and the presence of migratory fluids in any adjacent strata. In some instances, an intermediate string of casing may be a liner.

[0083] Finally, a production string **130** is provided. The production string **130** is hung from the intermediate casing string **120** using a liner hanger **132**. The production string **130** is a liner that is not tied back to the surface **101**. A substantial portion of the production liner **130** is preferably cemented in place.

[0084] The production liner **130** has a lower end **134** that extends substantially to an end **154** of the wellbore **150**. For this reason, the wellbore **150** is said to be completed as a

**Attorney Docket No. 2013EM219**

cased-hole well. In one aspect, the production string **130** is not a liner but is a casing string that extends back to the surface **101**.

[0085] In order to create fluid communication between a bore **135** of the liner **130** and the surrounding rock matrix making up the subsurface formation **155**, the liner **130** has been perforated. Perforations are seen at **159**. In the view of **Figure 1**, one set of perforations **159** is provided. However, it is understood that additional sets of perforations may be provided in separate zones. Those zones, in turn, may be isolated through the use of downhole tools such as packers and sliding sleeves (not shown).

[0086] To enhance the exposure of the rock formation **155** to the pipe bore **135**, the operator will fracture the formation **155**. This is done by injecting a fracturing fluid under high pressure through the perforations **159** and into the formation **155**. The fracturing process creates fractures **158** into the subsurface formation **155**.

[0087] The wellbore **150** also includes a string of production tubing **140**. The production tubing **140** extends from the well head **160** down to the subsurface formation **155**. In the arrangement of **Figure 1**, the production tubing **140** terminates proximate an upper end of the subsurface formation **155**. A production packer **142** is provided at a lower end of the production tubing **140** to seal off an annular region **145** between the tubing **140** and the surrounding production liner **130**. However, the production tubing **140** may optionally extend closer to the end **134** of the liner **130**.

[0088] The production tubing **140** is made up of a series of pipe joints. The joints are typically 30 to 40 feet in length. The pipe joints are typically threadably coupled and then lowered into the wellbore **150** during completion, drilling, or production operations.

[0089] It is desirable to monitor subsurface conditions below the level of the production tubing **140**. To accomplish this, a series of novel communications nodes is provided herein. The communications nodes are referred to as sensor communications nodes and acoustic communications nodes. The nodes are not visible in **Figure 1**; however, nodes are indicated at **170** and **175** in **Figures 2A** through **2C**.

[0090] **Figure 2A** is an enlarged side, cross-sectional view of a portion of the wellbore **150** of **Figure 1**. Here, a portion **2A** of the wellbore **150** is shown. Portion **2A** is taken along the production casing **130**. Perforations **159** are seen. The perforations **159** extend through the casing **130**, through a cement matrix **137** in the annulus **115**, and into the formation **155**.

[0091] **Figure 2A** also shows a series of communications nodes. The two lowermost communications nodes are shown at **175**. These are referred to as sensor communications nodes. The sensor communications nodes **175** are shown affixed to an outer diameter of

Attorney Docket No. 2013EM219

the production casing **130**. However, it is understood that the nodes **175** may alternatively be placed on an inner diameter of the production casing **130**.

[0092] Each sensor communications node **170** preferably comprises a housing having a sealed bore. Each sensor communications node **170** also has an associated sensor and a transmitter. These components are not visible in the view of **Figure 2A**. However, **Figure 5** offers an enlarged view of a joint of pipe **500** and a communications node **550**. The illustrative communications node **550** is shown exploded away from the pipe joint **500** for clarity.

[0093] The illustrated pipe joint **500** is intended to represent a joint of wellbore production tubing **130**, but the technology is also applicable to other tubulars, such as well casing, pipeline joints, and drill pipe. The pipe joint **500** has an elongated wall **510** defining an internal bore **515**. The bore **515** transmits hydrocarbon fluids during an oil and gas production operation. The pipe joint **500** illustrates a box end **522** having internal threads such as may be provided by an integrated box end or by using an internally threaded collar as illustrated. The pipe joint **500** also includes a pin end **524** having external threads. The communications node **550** resides intermediate the box end **522** and the pin end **524**.

[0094] The communications node **550** shown in **Figure 5** is designed to be pre-welded onto the wall **510** of the pipe joint **500**. Alternatively, the communications node **550** may be glued to the wall **510** using an adhesive such as epoxy. However, it is preferred that the communications node **550** be configured to be selectively attachable to / detachable from a pipe joint **500** by mechanical means at the well site **100**. This may be done, for example, through the use of clamps. Such a clamping system is shown at **1000** in **Figure 10**, described more fully below. In any instance, the communications node **550** offers an independent communications device that is designed to be attached to a surface of a well pipe **500**.

[0095] In **Figure 5**, the communications node **550** includes an elongated body **551**. The body **551** supports a sensor, shown schematically at **552**. The body **551** also supports a transmitter, shown schematically at **554**. The transmitter **554** receives electrical signals from the sensor **552**, holds the signals in memory, and then transmits a wireless signal to a logging tool (shown at **900** in **Figure 9**) when the logging tool is run into the bore **515** of the pipe **500**. The transmitted signal is indicative of a subsurface condition as measured or detected by the sensor **552** over time.

[0096] It is preferred that the communications node **550** also be independently-powered. To this end, the communications node **550** may have batteries **556**. In one aspect, the batteries **556** are re-charged when the logging tool is passed through the bore **515** and



**Attorney Docket No. 2013EM219**

across the communications node **550**. This is beneficial as the useful life of a battery is limited, and is dependent on such factors as downhole temperature and energy demand from the node electronics.

[0097] Battery re-charging preferably takes place through electrical current induction. Electrical current induction is sometimes known as “inductive charging” or “wireless charging.” Inductive charging uses an electromagnetic field to transfer energy between two objects. Induction chargers typically use a first induction coil to create an alternating electromagnetic field from within a charging base station. The electromagnetic field is sensed by a second induction coil associated with an electrical device or battery.

[0098] In practice, energy is sent through an inductive coupling from the logging tool **900** to an electrical device within the communications node **550**. The electrical device takes advantage of the created magnetic energy to charge the batteries **556**. Thus, the second induction coil in the communications node **550** takes power from the electromagnetic field and converts it into an electrical current that charges the batteries **556**.

[0099] Other techniques may be used or developed for wirelessly re-charging the node batteries. These may include the use of mechanical vibration, or acoustic energy, for generating electrical current, or the use of heat or chemical means. In any instance, the communications node **550** offers an independently-powered device that is designed to quickly be attached to an external surface of a well pipe **500**.

[00100] Returning to **Figure 2A**, additional communications nodes are also shown. These are noted at **175**, and may be referred to as acoustic communications nodes. The acoustic communications nodes **175** are shown spaced along the production casing **130**.

[00101] The acoustic communications nodes **175** are configured generally in accordance with the sensor communications nodes **170** described above and as shown at **500**. However, the acoustic communications nodes **175** do not include sensors (such as sensor **552** of **Figure 5**), but are designed to receive data from and transmit data to adjacent acoustic communications nodes **175** using acoustic transceivers. In this way, acoustic signals indicative of a subsurface condition from a sensor **552** are sent node-to-node up to a last acoustic communications node. That last acoustic communications node is not shown in **Figure 2A**, but is technically another sensor communications node **170** as it stores the acoustically-generated signals in its memory until those signals are transmitted to the logging tool **900** using a transmitter **554**.

[00102] In operation, each sensor communications node **170** is in electrical communication with a sensor **552**. This may be by means of a short wire, or by means of wireless communication such as infrared or radio-frequency communication. The sensor

**Attorney Docket No. 2013EM219**

communications nodes **170** are configured to receive signals from the sensors **552**, wherein the signals represent a subsurface condition. The subsurface condition may be pressure. A pressure sensor may be, for example, a sapphire gauge or a quartz gauge. Sapphire gauges are preferred as they are considered more rugged for the high-temperature downhole environment. Alternatively, the sensors may be temperature sensors. Alternatively, the sensors may be microphones for detecting ambient noise, or geophones (such as a tri-axial geophone) for detecting the presence of micro-seismic activity. Alternatively still, the sensors may be fluid flow measurement devices such as a spinners, or fluid composition sensors, or formation sensors. The sensors may alternatively be strain gauges.

**[00103]** **Figure 6A** is a more detailed perspective view of a sensor communications node **600** as may be used in the wellbore of **Figure 2A**, in one embodiment. The sensor communications node **600** is uniquely designed to provide acoustic communication using a transceiver within a novel downhole housing assembly. This is beneficial when the operator desires to send wireless signals from a sensor communications node partially up the wellbore.

**[00104]** **Figure 6B** is a cross-sectional view of the communications node **600** of **Figure 6A**. The view is taken along the longitudinal axis of the node **600**. The sensor communications node **600** will be discussed with reference to **Figures 6A** and **6B**, together.

**[00105]** The communications node **600** first includes a housing **610**. The housing **610** is designed to be attached to an outer wall of a joint of wellbore pipe, such as the pipe joint **500** of **Figure 5**. Where the wellbore pipe is a carbon steel pipe joint such as drill pipe, casing or liner, the housing is preferably fabricated from carbon steel. This metallurgical match avoids galvanic corrosion at the coupling.

**[00106]** The housing **610** is dimensioned to be strong enough to protect internal electronics. In one aspect, the housing **610** has an outer wall **612** that is about 0.2 inches (0.51 cm) in thickness. A bore **605** is formed within the wall **612**. The bore **605** houses the electronics, shown in **Figure 6B** as a battery **630**, a power supply wire **635**, a transceiver **640**, and a circuit board **645**. The circuit board **645** will preferably include a micro-processor or electronics module that processes acoustic signals. An electro-acoustic transducer **642** is provided to convert acoustical energy to electrical energy (or vice-versa) and is coupled with outer wall **612** on the side attached to the tubular body. The transducer **642** is in electrical communication with a sensor **632**.

**[00107]** It is noted that in **Figure 6B**, the sensor **632** resides within the housing **610** of the communications node **600**. However, as noted, the sensor **632** may reside external to the

**Attorney Docket No. 2013EM219**

communications node **600**, such as above or below the node **600** along the wellbore **150**. In **Figure 6C**, a dashed line is provided showing an extended connection between an external sensor **632** and an electro-acoustic transducer **642**.

[00108] In either arrangement, the sensor **632** may be, for example, (i) a pressure sensor, (ii) a temperature sensor, (iii) an induction log, (iv) a gamma ray log, (v) a formation density sensor, (vi) a sonic velocity sensor, (vii) a vibration sensor, (viii) a resistivity sensor, (ix) a flow meter, (x) a microphone, (xi) a geophone, (xii) a strain gauge, or (xiii) a combinations thereof. In one aspect, the transducer **642** is the sensor itself. This allows active acoustic response along a section of casing, thereby allowing the operator to evaluate cement integrity.

[00109] It is noted that the sensor communications node **600** need not, and preferably does not, have an acoustic transceiver **640**; instead, part **640** of the communications node **600** is a transmitter (such as transmitter **554** shown schematically in **Figure 5**). Thus, the transmitter **640** is placed within the bore **605** of the housing **610** for sending wireless signals to the logging tool **900**.

[00110] Where the communications node **600** functions as an acoustic communications node **175** that is simply relaying acoustic signals up the wellbore, the communications node **600** need not have a transmitter. The only exception is for the last communications node in series, wherein the transducer **642** receives signals from the closest acoustic communications node **175** and stores those signals in memory until transmitted to the logging tool **900** using a transmitter.

[00111] **Figure 7** provides a cross-sectional view of a communications node **700** as may be used for a last sensor communications node **170** of **Figure 2A**. The housing **610**, the bore **605**, and other hardware components are generally constructed in accordance with the acoustic communications node **600** of **Figure 6A**. In addition, a transducer **642** is shown for converting acoustic signals into electrical signals. However, a memory **742** is shown for storing signals received from the one or more acoustic communications nodes **175**. These signals are multi-plexed so that a processor may correlate the signals with time and location within the wellbore. In addition, the sensor communications node **700** includes a transmitter **740**.

[00112] As with communications node **600**, communications node **700** will preferably have a battery **730**, a power supply wire **735**, and a circuit board **745**. The circuit board **745** will preferably include a micro-processor or electronics module that processes signals from a sensor **732**. The micro-processor may be associated with the memory **742**.

**Attorney Docket No. 2013EM219**

[00113] The communications nodes **600, 700** optionally have a protective outer layer **625**. The protective outer layer **625** resides external to the wall **612** and provides an additional thin layer of protection for the electronics. The communications nodes **600, 700** are also fluid-sealed within the housing **610** to protect the internal electronics. Additional protection for the internal electronics is available using an optional potting material.

[00114] The communications nodes **600, 700** also optionally each include shoes **800**. More specifically, the nodes **600, 700** include pairs of shoes **800** disposed at opposing ends of the wall **612**. Each of the shoes **800** provides a beveled face that helps prevent the node from hanging up on an external tubular body or the surrounding earth formation, as the case may be, during run-in or pull-out. The shoes **800** may have a protective outer layer **622** and an optional cushioning material **624** (shown in **Figure 6A**) under the outer layer **622**.

[00115] **Figures 8A** and **8B** are perspective views of an illustrative shoe **800** as may be used on an end of either of the communications nodes **600, 700**, in one embodiment. In **Figure 8A**, the leading edge or front of the shoe **800** is seen, while in **Figure 8B** the back of the shoe **800** is seen.

[00116] The shoe **800** first includes a body **810**. The body **810** includes a flat under-surface **812** that butts up against opposing ends of the wall **612** of the communications node **600** or **700**.

[00117] Extending from the under-surface **812** is a stem **820**. The illustrative stem **820** is circular in profile. The stem **820** is dimensioned to be received within opposing recesses **814** of the wall **612** of the nodes **600, 700**.

[00118] Extending in an opposing direction from the body **810** is a beveled surface **830**. As noted, the beveled surface **830** is designed to prevent the communications node **600** or **700** from hanging up on an object during run-in into a wellbore.

[00119] Behind the beveled surface **830** is a flat surface **835**. The flat surface **835** is configured to extend along the production casing **130** (or other tubular body) when the communications node **600** or **700** is attached to the tubular body **500**. In one aspect, the shoe **800** includes an optional shoulder **815**. The shoulder **815** creates a clearance between the flat surface **835** and the tubular body opposite the stem **820**.

[00120] Referring again to **Figure 2A**, three sensor communications nodes **170** and two acoustic communications nodes **175** are shown. Of course, any number of the respective nodes **170, 175** may be used. Indeed, all of the communications nodes may be sensor communications nodes **170**.

**Attorney Docket No. 2013EM219**

[00121] It is observed that the use of acoustic communications nodes **170** is potentially problematic. This approach relies upon all acoustic communications nodes **170** in a series functioning properly in order to relay data up the wellbore **150**. If one of the acoustic communications nodes **170** fails, data from the lower acoustic communications nodes is never relayed to a sensor communications node **170**, and that data is never harvested. Therefore, it is preferred that sensor communications nodes **175** be used in areas where acoustic continuity is unreliable, such as near a sliding sleeve or along perforations.

[00122] In the arrangement of **Figure 2A**, a sensor communications node **170** is shown at the top, followed by two acoustic communications nodes **175** that send signals up the casing **130** to the sensor communications node **170**. More than two acoustic communications nodes **175** may be placed there. Additionally, two sensor communications nodes **170** are placed along the wellbore **150** in between perforations **159**.

[00123] Each communications node receives signals from a corresponding sensor (shown at **632** in **Figure 6B** and at **732** in **Figure 7**). In the case of a sensor communications node **170**, the signal is a direct electrical signal. In the case of an acoustic communications nodes **175**, those signals are converted to acoustic signals, and then transmitted through the pipe to a next acoustic communications node **175**. Such acoustic waves are preferably at a frequency of between about 50 kHz and 500 kHz. More preferably, the acoustic wave are transmitted at a frequency of between about 100 kHz and 125 kHz. Those acoustic signals may be digitized by the micro-processor.

[00124] In one preferred embodiment, the acoustic telemetry data transfer is accomplished using multiple frequency shift keying (MFSK). Any extraneous noise in the signal is moderated by using known analog and/or digital signal processing methods. This noise removal and signal enhancement may involve conveying the acoustic signal through a signal conditioning circuit using, for example, a bandpass filter.

[00125] The transceiver in the acoustic communications nodes **175** will also produce acoustic telemetry signals. In one preferred embodiment, an electrical signal is delivered to an electromechanical transducer, such as through a driver circuit. In a preferred embodiment, the transducer is the same electro-acoustic transducer that originally received the MFSK data. The signal generated by the electro-acoustic transducer then passes through the housing **610** to the tubular body, that is, the liner **130**, and propagates along the tubular body to a next acoustic communication nodes **175**. In one aspect, the acoustic signal is generated and received by a magnetostrictive transducer comprising a coil wrapped around a core as the transceiver. In another aspect, the acoustic signal is generated and received by a piezo-electric ceramic transducer. In either case, the filtered signal is delivered up to a sensor communications node **170**.

Attorney Docket No. 2013EM219

[00126] In **Figure 2A**, communications nodes **170**, **175** are shown along **Section 2A** of the wellbore **150** of **Figure 1**. This section is located along the subsurface formation **155**, or pay zone. However, communications nodes **170** may also be placed in sections of the wellbore that are above the pay zone.

[00127] **Figure 2B** is another enlarged side, cross-sectional view of a portion of the wellbore **150** of **Figure 1**. Here, a portion **2B** of the wellbore **150** is shown. The portion is generally shown above the subsurface formation **155**.

[00128] In **Figure 2B**, two sensor communications nodes **170** are shown placed along an outer surface of the production casing **130**. In addition, a series of sensor communications nodes **170** is placed along an outer surface of the production tubing **140**. The sensor communications nodes **170** that reside along the production tubing **140** include sensors (shown at **732** in **Figure 7**) for collecting data indicative of a subsurface condition. Such a condition may be, for example, annular pressure, annular temperature, or the presence of noise suggesting that fluid is flowing above the packer **142**. The sensors **170** in **Figure 2B** are independently powered, such as through the use of batteries **730**.

[00129] In an alternate arrangement, the sensors **170** along the production tubing **140** may be powered via a power cable. **Figure 2C** is another enlarged side, cross-sectional view of a portion of the wellbore **150** of **Figure 1**. Here, a portion **2C** of the wellbore **150** is shown. Portion **2C** shows sensor communications nodes **170** spaced along the production tubing **140**. An insulated electric power cable **178** is shown extending down to the nodes **170** to provide electrical power to components.

[00130] The sensor communications nodes **170** gather data from the sensors **732** and store them in memory **742**. The data remains in memory **742** until it is harvested by the logging tool **900**.

[00131] **Figure 9** is a cross-sectional view of an upper portion of a wellbore **950**. Here, the logging tool **900** is seen being run into the wellbore **950** according to arrow "I." The logging tool **900** is placed proximate the end of a working line **910**. The working line **910** may be a "dumb" working line such as a slick line or coiled tubing. Alternatively, the working line **910** may provide electrical or optical communication with a processor at the surface **101**. Such a processor is shown at **190** in **Figure 1**.

[00132] The logging tool **900** is used to harvest data transmitted by sensor communications nodes **170** within the wellbore **950**. To this end, the logging tool **900** includes a receiver **920**. The receiver **920** wirelessly picks up transmissions from the transmitters **740** in the sensor communications nodes **700**. Data transmission may be by means of any wireless protocol, including Wi-Fi or BlueTooth.

**Attorney Docket No. 2013EM219**

[00133] The harvested signals are delivered to the surface **101**. In one aspect, signals are sent up the working line **910** using electrical or optical communication. In another aspect, the logging tool **900** is spooled back to the surface **101** and data is then uploaded from the logging tool **900** to the processor **190**. In this instance, the logging tool **900** will preferably be powered by batteries, shown schematically at **925**.

[00134] The processor **190** comprises a computer **192** with memory that processes the signals sent from the receiver **920**. The processor **192** may be incorporated into a computer having a screen and a separate keyboard **194**, as is typical for a desk-top computer. Alternatively, the computer **192** has an integral keyboard as is typical for a laptop or a personal digital assistant. In one aspect, the processor **190** is part of a multi-purpose "smart phone" having specific software applications, or "apps," and wireless connectivity.

[00135] In one arrangement, the communications nodes (such as nodes **600** with the shoes **800**) are welded onto an inner or outer surface of the tubular body, such as wall **310** of the pipe joint **300**. More specifically, the body **610** of the respective communications nodes **600** are welded onto the wall of the tubular body. In some cases, it may not be feasible or desirable to pre-weld the communications nodes **600** onto pipe joints before delivery to a well site. Further still, welding may degrade the tubular integrity or damage electronics in the housing **610**. Therefore, it is desirable to utilize a clamping system that allows a drilling or service company to mechanically connect / disconnect the communications nodes **600** along a tubular body as the tubular body is being run into a wellbore.

[00136] In the illustrative arrangements of **Figures 2A** through **2C**, the communications nodes **170**, **175** are secured to an outer surface of a tubular body in a wellbore. In one aspect, the securing is by means of at least one clamp.

[00137] **Figure 10** is a perspective view of a portion of a communications node system **1000** of the present invention, in one embodiment. The communications node system **1000** utilizes a pair of clamps **1010** for mechanically connecting a communications node **700** onto a tubular body **1030**.

[00138] The system **1000** first includes at least one clamp **1010**. In the arrangement of **Figure 10**, a pair of clamps **1010** is used. Each clamp **1010** abuts the shoulder **815** of a respective shoe **800**. Further, each clamp **1010** receives the base **835** of a shoe **800**. In this arrangement, the base **835** of each shoe **800** is welded onto an outer surface of the clamp **1010**. In this way, the clamps **1010** and the communications node **700** become an integral tool.

**Attorney Docket No. 2013EM219**

[00139] The illustrative clamps **1010** of **Figure 10** include two arcuate sections **1012**, **1014**. The two sections **1012**, **1014** pivot relative to one another by means of a hinge. Hinges are shown in phantom at **1015**. In this way, the clamps **1010** may be selectively opened and closed.

[00140] Each clamp **1010** also includes a fastening mechanism **1020**. The fastening mechanisms **1020** may be any means used for mechanically securing a ring onto a tubular body, such as a hook or a threaded connector. In the arrangement of **Figure 10**, the fastening mechanism is a threaded bolt **1025**. The bolt **1025** is received through a pair of rings **1022**, **1024**. The first ring **1022** resides at an end of the first section **1012** of the clamp **1010**, while the second ring **1024** resides at an end of the second section **1014** of the clamp **1010**. The threaded bolt **1025** may be tightened by using, for example, one or more washers (not shown) and threaded nuts **1027**.

[00141] In operation, a clamp **1010** is placed onto the tubular body **1030** by pivoting the first **1012** and second **1014** arcuate sections of the clamp **1010** into an open position. The first **1012** and second **1014** sections are then closed around the tubular body **1030**, and the bolt **1025** is run through the first **1022** and second **1024** receiving rings. The bolt **1025** is then turned relative to the nut **1027** in order to tighten the clamp **1010** and connected communications node **700** onto the outer surface of the tubular body **1030**. Where two clamps **1010** are used, this process is repeated.

[00142] The tubular body **1030** may be, for example, a string of casing, such as the casing string **130** of **Figure 1**. The wall **612** of the communications node **700** is ideally fabricated from a steel material having a resonance frequency compatible with the resonance frequency of the tubular body **1030**. In addition, the mechanical resonance of the wall **612** is at a frequency contained within the frequency band used for telemetry.

[00143] In one aspect, the communications node **700** is about 12 to 16 inches (0.30 to 0.41 meters) in length as it resides along the tubular body **1030**. Specifically, the housing **610** of the communications node **700** may be (0.20 to 0.25 meters) in length, and each opposing shoe **800** may be 2 to 5 inches (0.05 to 0.13 meters) in length. Further, the communications node **700** may be about 1 inch in width and 1 inch in height. The housing **610** of the communications node **700** may have a concave profile that generally matches the radius of the tubular body **1030**.

[00144] There are benefits to the use of an externally-placed communications node. For example, such a node will not interfere with the flow of fluids within the internal bore **515** of the pipe joint **500**. Further, installation and mechanical attachment can be readily assessed or adjusted, as necessary. In the case of acoustic communications nodes **175**, because the



**Attorney Docket No. 2013EM219**

acoustic signals are carried by the wall **510** of the pipe joint **500** itself, the data is largely unaffected by the fluids in the pipe joint **500**.

[00145] Returning again to **Figure 1**, **Figure 1** shows a wellbore **150** having been completed as a cased hole completion. However, the downhole telemetry system described herein has equal utility with respect to open hole completions. **Figure 3** shows a wellbore **350** having been completed as an open hole completion.

[00146] The wellbore **350** of **Figure 3** is generally constructed in accordance with the wellbore **150** of **Figure 1**. However, the wellbore **350** utilizes a sand control screen **360** that is placed below the production tubing **140**. The sand control screen **360** is actually a series of screen joints made up of an external filtering medium **361** and an internal base pipe **362**. A gravel pack **364** may optionally be installed around the sand control screen **160**. Together, the gravel pack **364** and the filtering medium **361** prevent formation fines and sand particles from invading the wellbore **350**. Production fluids move through the gravel pack **364**, the filtering medium **361** and the slotted base pipe **362**, and into the bore **365** of the sand control screen **360**.

[00147] **Figure 4A** is an enlarged side, cross-sectional view of a portion of the wellbore **350** of **Figure 3**. Here, portion **4A** of the wellbore **350** of **Figure 3** is shown. In **Figure 4A**, sensor communications nodes **170** have been placed around the sand control screen **360** along subsurface formation **355**.

[00148] **Figure 4B** is another enlarged side, cross-sectional view of a portion of the wellbore **350** of **Figure 3**. Here, portion **4B** is shown. In **Figure 4B**, sensor communications nodes **170** have been placed around the sand control screen **360** and along a lower portion of the production tubing **140**.

[00149] It is understood that the sensor communications nodes **170** may be placed on inner or outer surfaces of the base pipe **362**. However, a benefit of the sensor communications nodes **170** is that they may be placed on an outer surface of the sand control screen joints as they do not rely upon the resonant pipe as the carrier medium for the acoustic transmission of data.

[00150] **Figure 3**, together with **Figures 4A** and **4B**, demonstrates the use of a downhole telemetry system that employs sensor communications nodes **170** and a logging tool **900** in a vertical, open-hole completion. However, the system has equal applicability to wellbores that are completed horizontally.

[00151] **Figure 11** is a cross-sectional view of a wellbore **1100** having been completed in an alternate manner. Here, the illustrative wellbore **1100** has been completed as an open

Attorney Docket No. 2013EM219

hole completion, with a horizontal portion **1105**. The horizontal portion **1105** resides along a subsurface formation **1155**, or pay zone.

[00152] A sand control screen **360** has been placed along the subsurface formation **1105** in horizontal orientation. The sand control screen **360** extends below a packer **142**. It is understood that the sand control screen **360** is actually a series of joints of screen, with each joint having a filter medium **361** (referred to as the “screen”) wrapped or wound around a base pipe **162**. The screen **361** serves as an external filtering medium.

[00153] The slotted base pipe **362** extends below the production tubing **140**. The base pipe **362** is slotted to allow in ingress of filtered formation fluids into the wellbore **1150**. The base pipe **362** resides within the joints of screen **361** and is in fluid communication with the production tubing **140**.

[00154] It is preferred, though not required, to place a gravel slurry **364** around the screen **361** to support the surrounding formation **1155** and to provide further fluid filtering. This is known as a gravel pack. The use of sand control screens **360** with gravel packs **364** allows for greater fluid communication with the surrounding rock matrix while still providing support for the wellbore **1150**.

[00155] Because the wellbore **1150** is completed as an open hole, the production casing **130** need not extend below the packer **142**. No perforations or fractures are needed. Therefore, these aspects of the horizontal portion **1105** of the wellbore **1150** are not seen.

[00156] In the wellbore arrangement of **Figure 11**, sensor communications nodes **170** reside along the slotted base pipe **362**. The sensor communications nodes **170** use sensors that sense, for example, temperature and/or pressure along the sand control screen **360**. The sensor communications nodes **170** record signals sent from the respective sensors until the data is retrieved by the logging tool **900**.

[00157] Of interest, the wellbore **1150** of **Figure 11** includes an inflow control device **1175**. The inflow control device **1175** may be a sliding sleeve or a restricted orifice. Sensor communications nodes **1170** may optionally be placed along one of the inflow-control devices **1175** to monitor fluid flow, fluid temperature, or other wellbore parameter. In one aspect, the communications node **1170** may be programed to close or to adjust an inflow control device **1175** when a wellbore parameter is sensed. For example, if rate of flow along an inflow control device **1175** appears too low, a signal may be sent from the communications node **1170** automatically to further open a sliding sleeve or orifice. Similarly, a signal may be sent to a sliding sleeve **1175**, telling a sleeve to close further, or to completely close. This provides a “smart well” that controls an ingress of the production

**Attorney Docket No. 2013EM219**

fluids along selected portions of the formation. This is particularly beneficial for wells having horizontal completions that extend many thousands of feet.

[00158] Beneficially, electrical or electro-magnetic energy may be sent from a logging tool **900** to re-energize batteries operating in the inflow control devices **1175** and associated communications nodes **1170**. For the horizontally-completed wellbore **1150**, the working line will be a string of coiled tubing.

[00159] **Figures 1, 3 and 11** present illustrative wellbores **150, 350, 1150** having a downhole telemetry system that uses a series of sensor communications nodes having associated transmitters. The transmitters deliver wireless signals to a receiver in a logging tool. In each of **Figures 1, 3 and 11**, the top of the drawing page is intended to be toward the surface and the bottom of the drawing page toward the well bottom. While wells commonly are completed in substantially vertical orientation, it is understood that wells may also be inclined and even horizontally completed. When the descriptive terms “up” and “down” or “upper” and “lower” or similar terms are used in reference to a drawing, they are intended to indicate location on the drawing page, and not necessarily orientation in the ground, as the present inventions have utility no matter how the wellbore is orientated.

[00160] A method for transmitting data in a wellbore is also provided herein. The method preferably employs the communications node **700** of **Figure 7** and the clamps **1010** of **Figure 10**.

[00161] **Figure 12** provides a flow chart for a method **1200** of transmitting data in a wellbore. The method **1200** uses a plurality of communications nodes situated along a tubular body to accomplish a hybrid wired-and-wireless transmission of data along the wellbore. The wellbore penetrates into a subsurface formation, allowing for the communication of a wellbore condition at the depth of the subsurface formation up to the surface.

[00162] The method **1200** first includes placing one or more or, more preferably, two or more downhole sensors along the wellbore. This is shown at Box **1210**. The sensors are placed proximate a depth of the subsurface formation. The sensors may be, for example, pressure sensors, temperature sensors, formation logging tools or casing strain gauges.

[00163] The method **1200** also includes generating signals at the downhole sensors. This is provided at Box **1220**. The signals are indicative of subsurface conditions.

[00164] The method **1200** further includes providing sensor communications nodes along the wellbore. This is indicated at Box **1230**. The sensor communications nodes are also placed proximate a depth of the subsurface formation. Preferably, the sensors from step **1210** reside within a housing of an associated sensor communications node. Also, the

**Attorney Docket No. 2013EM219**

sensor communications nodes are preferably clamped to an outer surface of a string of production casing.

**[00165]** The sensor communications nodes preferably reside on an outer diameter of a string of production casing. Alternatively or in addition, each of the sensor communications nodes reside on an outer diameter of a joint of production tubing. Alternatively or in addition, each of the sensor communications nodes resides on either an inner diameter or an outer diameter of joints of sand control screen, such as along the base pipe of sand control screen joints.

**[00166]** Each of the sensor communications nodes preferably has an independent power source. The independent power source may be, for example, batteries or a fuel cell. In addition, each of the sensor communications nodes has a transmitter. The transmitter is designed and configured to transmit wireless signals indicative of the subsurface condition or wellbore parameter being sensed by the sensors.

**[00167]** The method **1200** additionally includes running a logging tool into the wellbore. This is indicated at Box **1240**. The logging tool includes a wireless receiver. The logging tool is positioned proximate the end of a working line. The working line may be, for example, a slick line, an insulated electric line, coiled tubing or a fiber optic cable.

**[00168]** The method **1200** also includes harvesting data from the sensor communications nodes. This is provided at Box **1250**. As the logging tool passes across the sensor communications nodes, the receiver picks up the wireless signals from the transmitter.

**[00169]** The method **1200** further includes receiving the harvested downhole data at the surface. This is seen at Box **1260**. In one embodiment, receiving the harvested data comprises transmitting the harvested data from the logging tool up a communications wire in the working line and to a processor at the surface. In this instance, the communications wire may be an insulated electrical cable or a fiber optic cable. In another embodiment, receiving the harvested data comprises storing the harvested data in memory on the logging tool, pulling the running tool from the wellbore, retrieving the logging tool, and then uploading the harvested data onto a processor at the surface.

**[00170]** In either instance, the method **1200** will also include processing the signals received at the surface. This is shown at Box **1270**. The signals are processed for analysis of the subsurface conditions. Analysis may be by an operator, by software, or both.

**[00171]** Optionally, additional sensor communications nodes may be placed above the depth of the subsurface formation. This is seen at Box **1280**. Optionally, separate acoustic communications nodes may be provided. This is seen at Box **1290**. The acoustic

**Attorney Docket No. 2013EM219**

communications nodes may be placed in series above an upper sensor communications node, or even between sensor communications nodes.

**[00172]** Each of the acoustic communications nodes has an electro-acoustic transceiver for sending and receive acoustic waves. Preferably, a frequency would be selected that is between about 100 kHz and 125 kHz to more closely match the anticipated resonance frequency of the pipe material itself.

**[00173]** The acoustic communications nodes are configured to transmit signals generated by one of the sensor communications nodes that is indicative of a subsurface conditions acoustically. In one aspect, piezo wafers or other piezoelectric elements are used to transmit the acoustic signals. In another aspect, multiple stacks of piezoelectric crystals or other magnetostrictive devices are used. Signals are created by applying electrical signals of a designated frequency across one or more piezoelectric crystals, causing them to vibrate at a rate corresponding to the frequency of the desired acoustic signal.

**[00174]** In one aspect, the data transmitted between the subsurface communications nodes is represented by acoustic waves according to a multiple frequency shift keying (MFSK) modulation method. Although MFSK is well-suited for this application, its use as an example is not intended to be limiting. It is known that various alternative forms of digital data modulation are available, for example, frequency shift keying (FSK), multi-frequency signaling (MF), phase shift keying (PSK), pulse position modulation (PPM), and on-off keying (OOK). In one embodiment, every 4 bits of data are represented by selecting one out of sixteen possible tones for broadcast.

**[00175]** Acoustic telemetry along tubulars is characterized by multi-path or reverberation which persists for a period of milliseconds. As a result, a transmitted tone of a few milliseconds duration determines the dominant received frequency for a time period of additional milliseconds. Preferably, the communication nodes determine the transmitted frequency by receiving or "listening to" the acoustic waves for a time period corresponding to the reverberation time, which is typically much longer than the transmission time. The tone duration should be long enough that the frequency spectrum of the tone burst has negligible energy at the frequencies of neighboring tones, and the listening time must be long enough for the multipath to become substantially reduced in amplitude. In one embodiment, the tone duration is 2 ms, then the transmitter remains silent for 48 milliseconds before sending the next tone. The receiver, however, listens for  $2 + 48 = 50$  ms to determine each transmitted frequency, utilizing the long reverberation time to make the frequency determination more certain. Beneficially, the energy required to transmit data is reduced by transmitting for a short period of time and exploiting the multi-path to extend the listening time during which the transmitted frequency may be detected.

**Attorney Docket No. 2013EM219**

[00176] In one embodiment, an MFSK modulation is employed where each tone is selected from an alphabet of 16 tones, so that it represents 4 bits of information. With a listening time of 50 ms, for example, the data rate is 80 bits per second.

[00177] The tones are selected to be within a frequency band where the signal is detectable above ambient and electronic noise at least two nodes away from the transmitter node so that if one node fails, it can be bypassed by transmitting data directly between its nearest neighbors above and below. In one example the tones are evenly spaced in period within a frequency band from about 50 kHz to 500 kHz.

[00178] In one aspect, the electro-acoustic transceivers in the acoustic communications nodes receive acoustic waves at a first frequency, and re-transmit the acoustic waves at a second different frequency. The electro-acoustic transceivers listen for the acoustic waves generated at the first frequency for a longer time than the time for which the acoustic waves were generated at the first frequency by a previous communications node. Ultimately, acoustic signals are sent up the wellbore and to another sensor communications node, that upper sensor communications node having a memory and a transmitter.

[00179] As can be seen, a novel downhole telemetry system is provided, as well as a novel method for the electro-acoustic transmission of information using a plurality of data transmission nodes.

[00180] As noted above, the downhole telemetry system may be used to adjust the flow of production fluids into a wellbore. Thus, a method for activating a sliding sleeve in a wellbore is also provided herein.

[00181] While it will be apparent that the inventions herein described are well calculated to achieve the benefits and advantages set forth above, it will be appreciated that the inventions are susceptible to modification, variation and change without departing from the spirit thereof.

Attorney Docket No. 2013EM219

### Claims

What is claimed is:

1. A method of transmitting data along a wellbore up to a surface, comprising:
  - placing one or more downhole sensors along the wellbore proximate a depth of a subsurface formation;
  - generating signals at the downhole sensors that are indicative of one or more subsurface conditions;
  - providing one or more sensor communications nodes along the wellbore, each sensor communications node being configured to process signals generated by a corresponding downhole sensor, and transmit those signals via a transmitter;
  - running a logging tool into the wellbore proximate the end of a working line, the logging tool having a receiver;
  - using the receiver, harvesting data from one or more of the sensor communications nodes from the transmitter; and
  - receiving the harvested data at the surface.
2. The method of claim 1, wherein the surface is an earth surface.
3. The method of claim 1, wherein the surface is a water surface.
4. The method of claim 1, wherein the sensors are (i) pressure sensors, (ii) temperature sensors, (iii) induction logs, (iv) gamma ray logs, (v) formation density sensors, (vi) sonic velocity sensors, (vii) vibration sensors, (viii) resistivity sensors, (ix) flow meters, (x) microphones, (xi) geophones, (xii) strain gauges, or (xiii) combinations thereof.
5. The method of claim 4, wherein receiving the harvested data comprises:
  - transmitting the harvested data from the logging tool up a communications wire in the working line and to a processor at the surface; and
  - processing the data at the surface for analysis.
6. The method of claim 5, wherein the communications wire is an insulated electrical cable or a fiber optic cable.
7. The method of claim 4, wherein receiving the harvested data comprises:
  - storing the harvested data in memory on the logging tool;
  - pulling the working line from the wellbore;
  - retrieving the logging tool;

**Attorney Docket No. 2013EM219**

uploading the harvested data onto a processor at the surface; and  
processing the data for analysis.

8. The method of claim 4, wherein:  
the one or more downhole sensors comprises at least two downhole sensors; and  
the one or more sensor communications nodes comprises at least two corresponding sensor communications nodes.
9. The method of claim 8, wherein the at least two sensor communications nodes reside on either an inner diameter or an outer diameter of a string of production casing.
10. The method of claim 9, wherein:  
each of the at least two sensor communications nodes reside on an outer diameter of a joint of production casing; and  
each sensor communications node comprises a housing fabricated from a steel material, and
11. The method of claim 10, wherein each sensor communications node further comprises at least one clamp for radially attaching the sensor communications node onto an outer surface of the production casing.
12. The method of claim 11, wherein the at least one clamp comprises:  
a first arcuate section;  
a second arcuate section;  
a hinge for pivotally connecting the first and second arcuate sections; and  
a fastening mechanism for securing the first and second arcuate sections around an outer surface of the subsurface pipe.
13. The method of claim 4, wherein the one or more sensor communications nodes reside on either an inner diameter or an outer diameter of joints of sand control screen.
14. The method of claim 4, wherein the one or more sensor communications nodes reside on either an inner diameter or an outer diameter of a string of production tubing.
15. The method of claim 4, wherein:  
the one or more downhole sensors comprises at least two downhole sensors;  
the one or more sensor communications nodes comprises at least two corresponding sensor communications nodes;  
each of the at least two sensor communications nodes resides on an outer diameter of a joint of production tubing; and



**Attorney Docket No. 2013EM219**

each sensor communications node comprises a housing fabricated from a steel material.

16. The method of claim 15, wherein each sensor communications node further comprises at least one clamp for radially attaching the sensor communications node onto an outer surface of the production tubing.

17. The method of claim 15, wherein each of the two or more sensor communications nodes receives power from (i) a cable extending from the surface, or (ii) one or more batteries residing within the housing.

18. The method of claim 4, further comprising:

running joints of steel pipe into the wellbore, the joints of pipe being connected by threaded couplings to form a pipe string;

attaching a series of acoustic communications nodes to the joints of pipe according to a pre-designated spacing, wherein adjacent acoustic communications nodes are configured to communicate by acoustic signals transmitted through the joints of pipe, and wherein each of the acoustic communications nodes comprises:

a housing having a sealed bore;

an electro-acoustic transducer and associated transceiver residing within the housing configured to relay signals, with each signal representing a packet of information that comprises an identifier for a sensor communications node originally transmitting the signal, and an acoustic waveform indicative of a subsurface condition; and

an independent power source also residing within the housing for providing power to the transceiver, and with the housing being fabricated from a material having a resonance frequency that is within the frequency band used for the acoustic signals; and

sending acoustic signals from the acoustic communications nodes, node-to-node, to an upper sensor communications nodes having memory and a transmitter.

19. The method of claim 18, wherein the pipe string is a section of production casing.

20. The method of claim 18, wherein each of the one or more downhole sensors resides within the housing of a corresponding sensor communications node.

21. The method of claim 18, wherein:

each of the acoustic communications nodes further comprises at least one clamp for radially attaching the communications node onto an outer surface of a subsurface pipe;

**Attorney Docket No. 2013EM219**

the subsurface pipe represents a joint of casing, a joint of liner, or a base pipe of a joint of sand control screen; and

the step of providing one or more acoustic communications nodes along the wellbore comprises clamping the communications nodes to an outer surface of the subsurface pipe.

22. The method of claim 4, further comprising:

transmitting energy from the logging tool to the sensor communications nodes to re-charge a battery within the sensor communications nodes.

23. A downhole acoustic telemetry system, comprising:

one or more downhole sensors residing along a wellbore proximate a depth of a subsurface formation, with each of the downhole sensors being configured to sense a subsurface condition and then send a signal indicative of that subsurface condition;

one or more sensor communications nodes also residing along the wellbore proximate a depth of the subsurface formation, wherein each of the sensor communications nodes comprises:

a housing having a sealed bore, and

a transmitter residing with the sealed bore for transmitting wireless signals indicative of the subsurface condition;

a logging tool having a receiver that is configured to harvest the wireless signals from the transmitters; and

a working line configured to run the logging tool into a wellbore proximate an end of the working line.

24. The acoustic telemetry system of claim 23, wherein the sensors are (i) pressure sensors, (ii) temperature sensors, (iii) induction logs, (iv) gamma ray logs, (v) formation density sensors, (vi) sonic velocity sensors, (vii) vibration sensors, (viii) resistivity sensors, (ix) flow meters, (x) microphones, (xi) geophones, (xii) strain gauges, or (xiii) combinations thereof.

25. The acoustic telemetry system of claim 23, wherein each of the downhole sensors resides within the housing of a corresponding sensor communications node.

26. The acoustic telemetry system of claim 23, wherein each of the downhole sensors resides adjacent the housing of a corresponding sensor communications node.

27. The acoustic telemetry system of claim 23, wherein the logging tool further comprises a memory for storing the harvested data until the logging tool is retrieved back to the surface.

**Attorney Docket No. 2013EM219**

28. The acoustic telemetry system of claim 23, wherein the working line comprises an insulated electric cable or a fiber optic cable for transmitting harvested data to the surface in real time.
29. The acoustic telemetry system of claim 23, wherein the one or more sensor communications nodes reside on either an inner diameter or an outer diameter of a string of production casing within the wellbore.
30. The acoustic telemetry system of claim 23, wherein:  
the one or more downhole sensors comprises at least two downhole sensors;  
the one or more sensor communications nodes comprises at least two corresponding sensor communications nodes;  
each of the sensor communications nodes reside on an outer diameter of a joint of production casing within the wellbore; and  
each sensor communications node comprises at least one clamp for radially attaching the sensor communications node onto an outer surface of the production casing.
31. The acoustic telemetry system of claim 30, wherein the at least one clamp comprises:  
a first arcuate section;  
a second arcuate section;  
a hinge for pivotally connecting the first and second arcuate sections; and  
a fastening mechanism for securing the first and second arcuate sections around an outer surface of the subsurface pipe.
32. The acoustic telemetry system of claim 31, wherein:  
each of the acoustic communications nodes further comprises a first shoe at the first end of the housing and a second shoe at the second end of the housing;  
the first shoe and the second shoe each comprises:  
a beveled edge designed to face away from the tubular body,  
a flat surface designed to face towards the tubular body, and  
a shoulder providing a clearance between the flat surface and the tubular body configured to receive a clamp.
33. The acoustic telemetry system of claim 23, wherein the one or more sensor communications nodes reside along either an inner diameter or an outer diameter of joints of sand control screen.

**Attorney Docket No. 2013EM219**

34. The acoustic telemetry system of claim 23, wherein the one or more sensor communications nodes reside on either an inner diameter or an outer diameter of a string of production tubing within the wellbore.

35. The acoustic telemetry system of claim 23, wherein:  
the one or more downhole sensors comprises at least two downhole sensors;  
the one or more sensor communications nodes comprises at least two corresponding sensor communications nodes;  
each of the sensor communications nodes reside on an outer diameter of a joint of production tubing within the wellbore; and  
each sensor communications node comprises at least one clamp for radially attaching the sensor communications node onto an outer surface of the production tubing.

36. The acoustic telemetry system of claim 35, further comprising:  
a power cable extending from the surface to provide power to the two or more sensor communications nodes.

37. The acoustic telemetry system of claim 23, further comprising:  
an upper sensor communications node having a memory and a transmitter; and  
two or more acoustic communications nodes attached to joints of subsurface pipe within the wellbore according to a pre-designated spacing, wherein adjacent acoustic communications nodes are configured to communicate by acoustic signals transmitted through the joints of pipe, and wherein each of the acoustic communications nodes comprises:

a housing having a sealed bore;

an electro-acoustic transducer and associated transceiver residing within the housing configured to relay signals from a sensor communications node, node-to-node, up to the upper sensor communications node, with each signal representing a packet of information that comprises an identifier for the sensor communications node originally transmitting the signal, and an acoustic waveform indicative of a subsurface condition; and

an independent power source also residing within the housing for providing power to the transceiver, and with the housing being fabricated from a material having a resonance frequency that is within the frequency band used for the acoustic signals;

and wherein the upper sensor communications node is configured to receive acoustic signals from the acoustic communications nodes, store them in memory,

**Attorney Docket No. 2013EM219**

and transmit them to the logging tool when the logging tool passes across the upper sensor communications node.

38. The acoustic telemetry system of claim 37, wherein the joints of pipe form a section of production casing.

39. The acoustic telemetry system of claim 38, wherein:  
each of the acoustic communications nodes further comprises at least one clamp;  
and

each of the two or more acoustic communications nodes is clamped onto an outer surface of the production casing.

40. The acoustic telemetry system of claim 23, wherein at least one of the sensor communications nodes resides within or is in contact with a rock matrix making up the surface formation.

41. The acoustic telemetry system of claim 23, wherein at least one of the sensor communications nodes resides along a downhole tool.

42. The acoustic telemetry system of claim 41, wherein the downhole tool is a sliding sleeve or an inflow control device.

43. The acoustic telemetry system of claim 42, wherein the logging tool is configured to transmit an instruction to adjust the position of the downhole tool.

FIG. 1

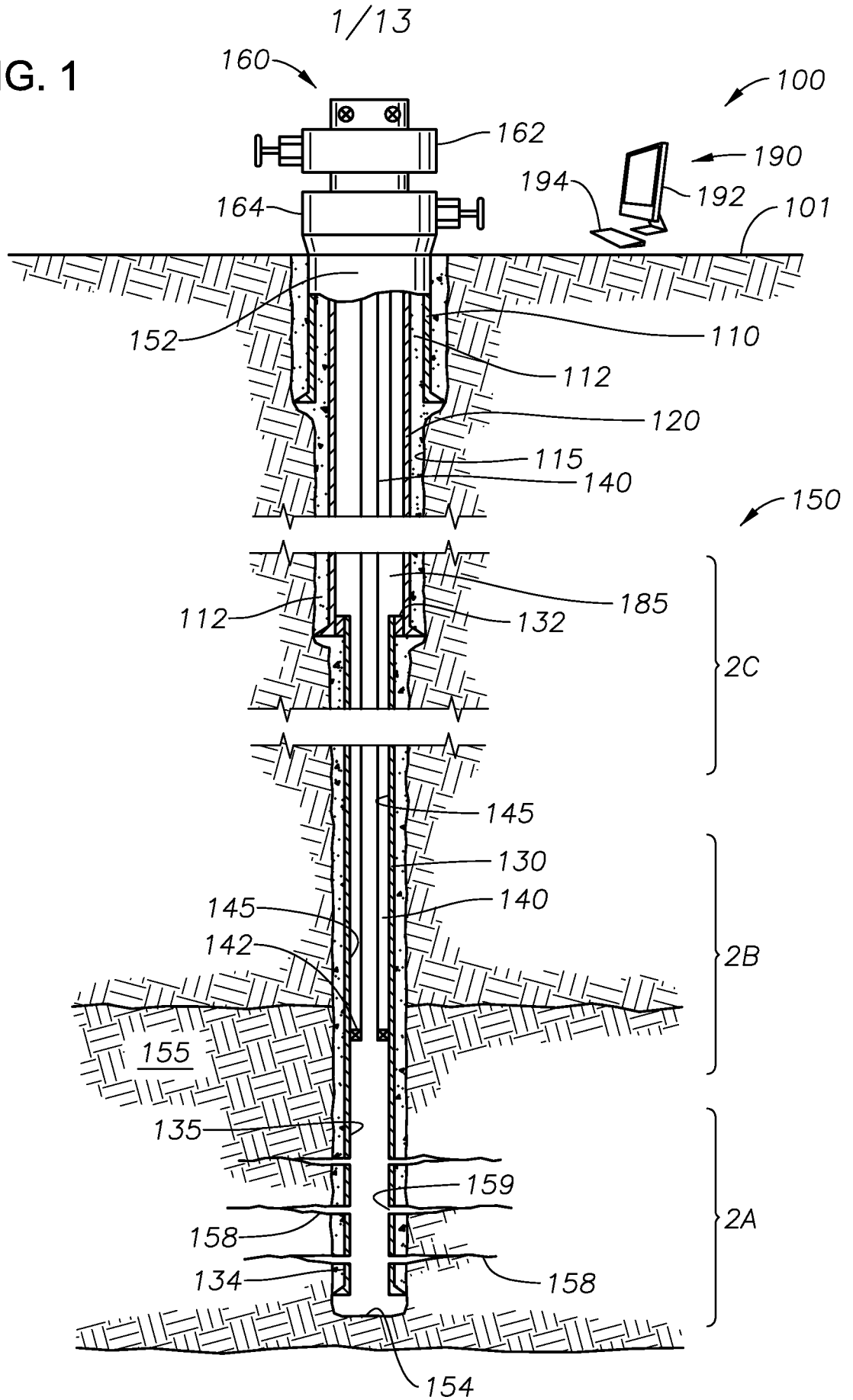

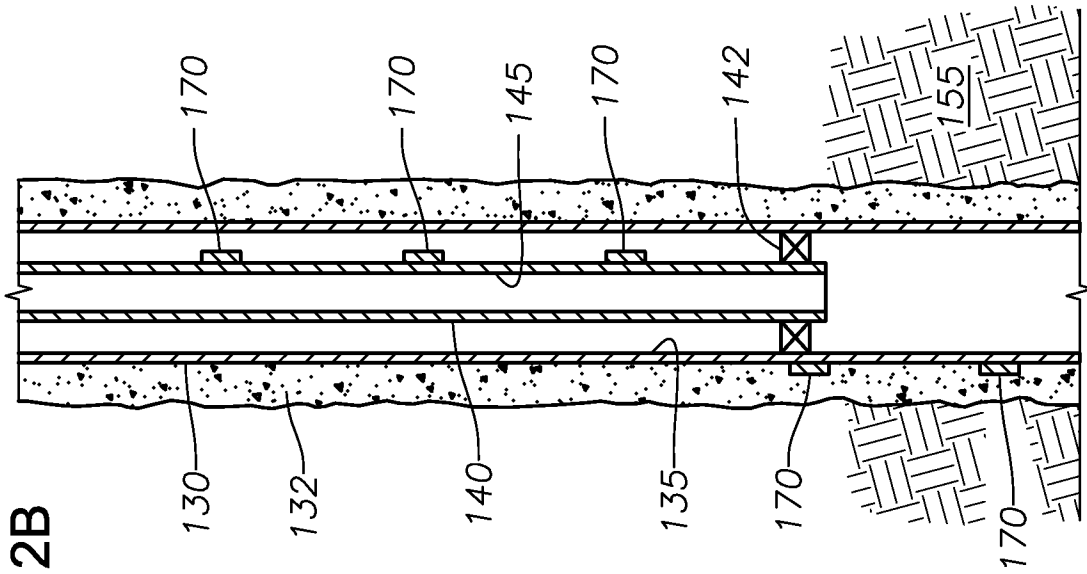

FIG. 2B

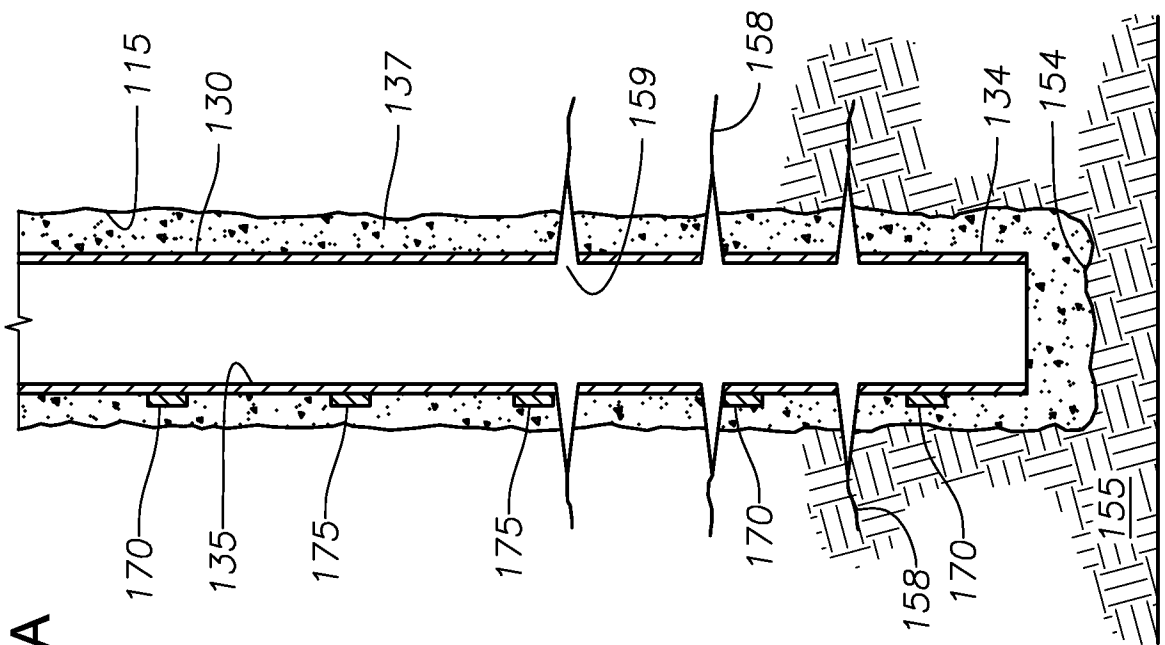
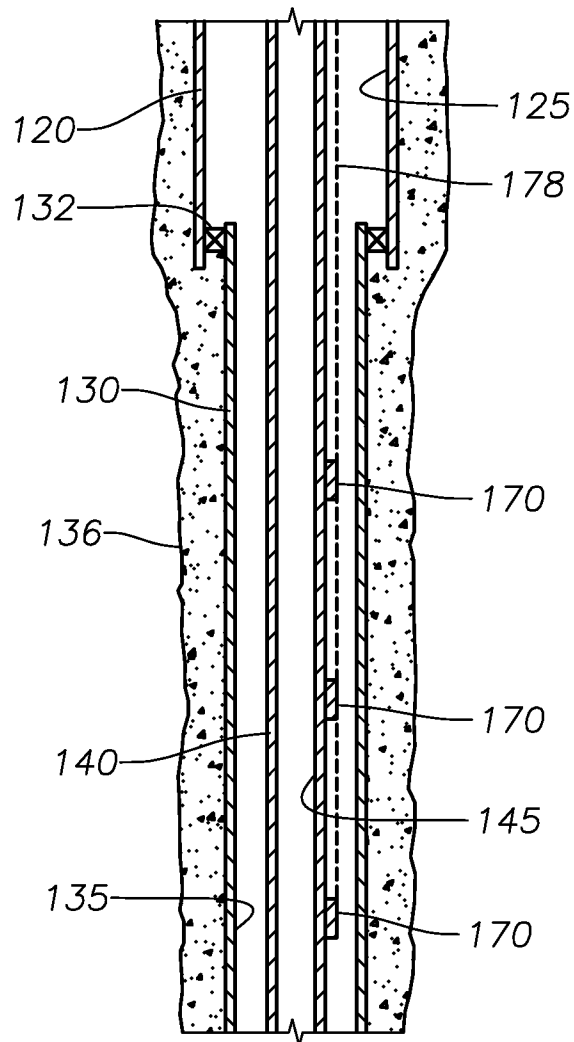

FIG. 2A

3/13

FIG. 2C





4/13

FIG. 3

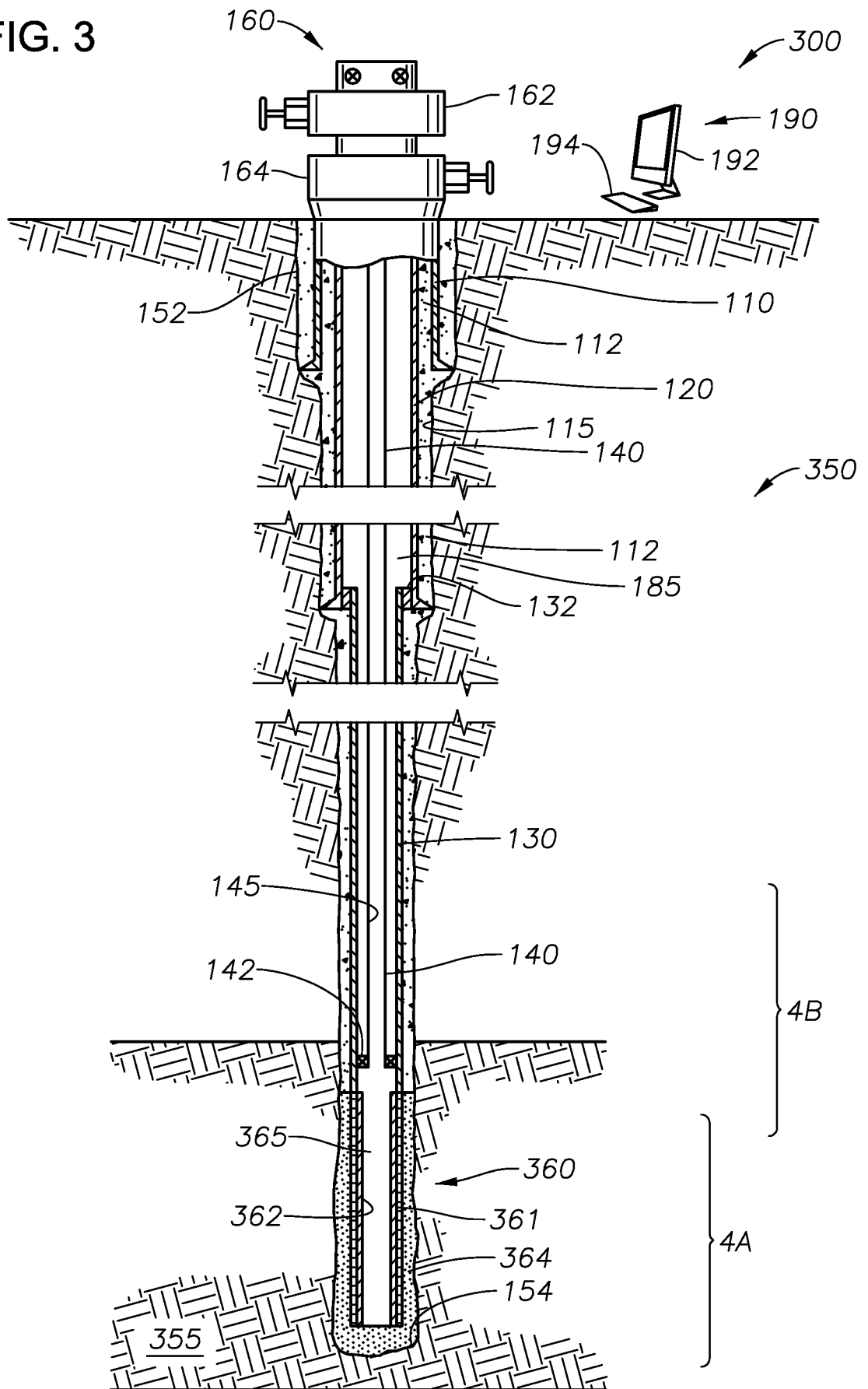

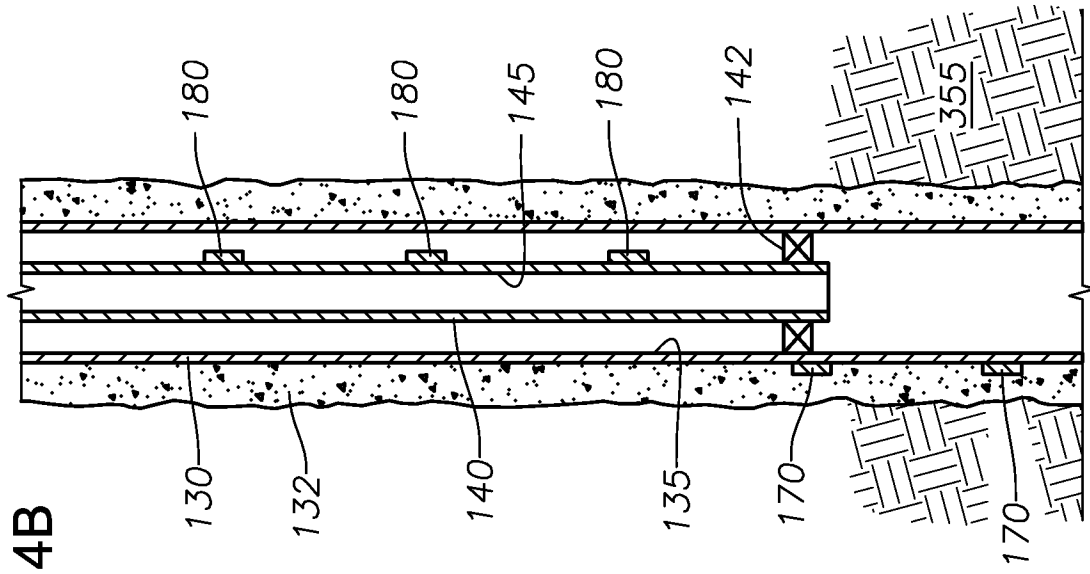

FIG. 4B

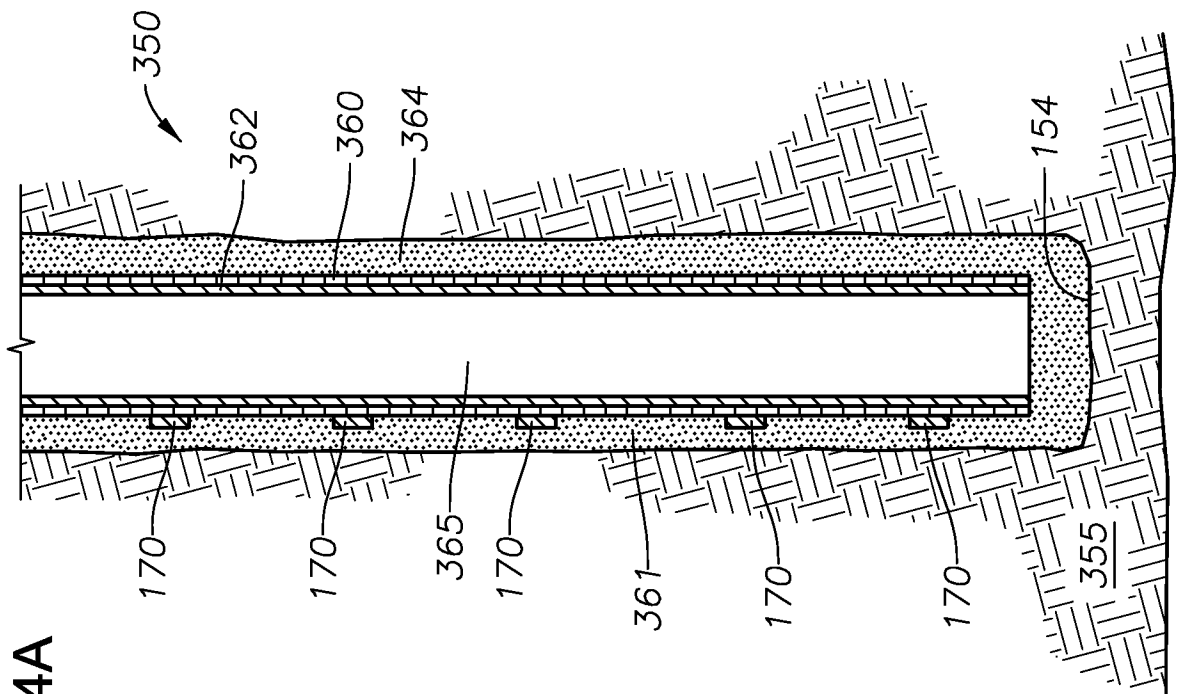
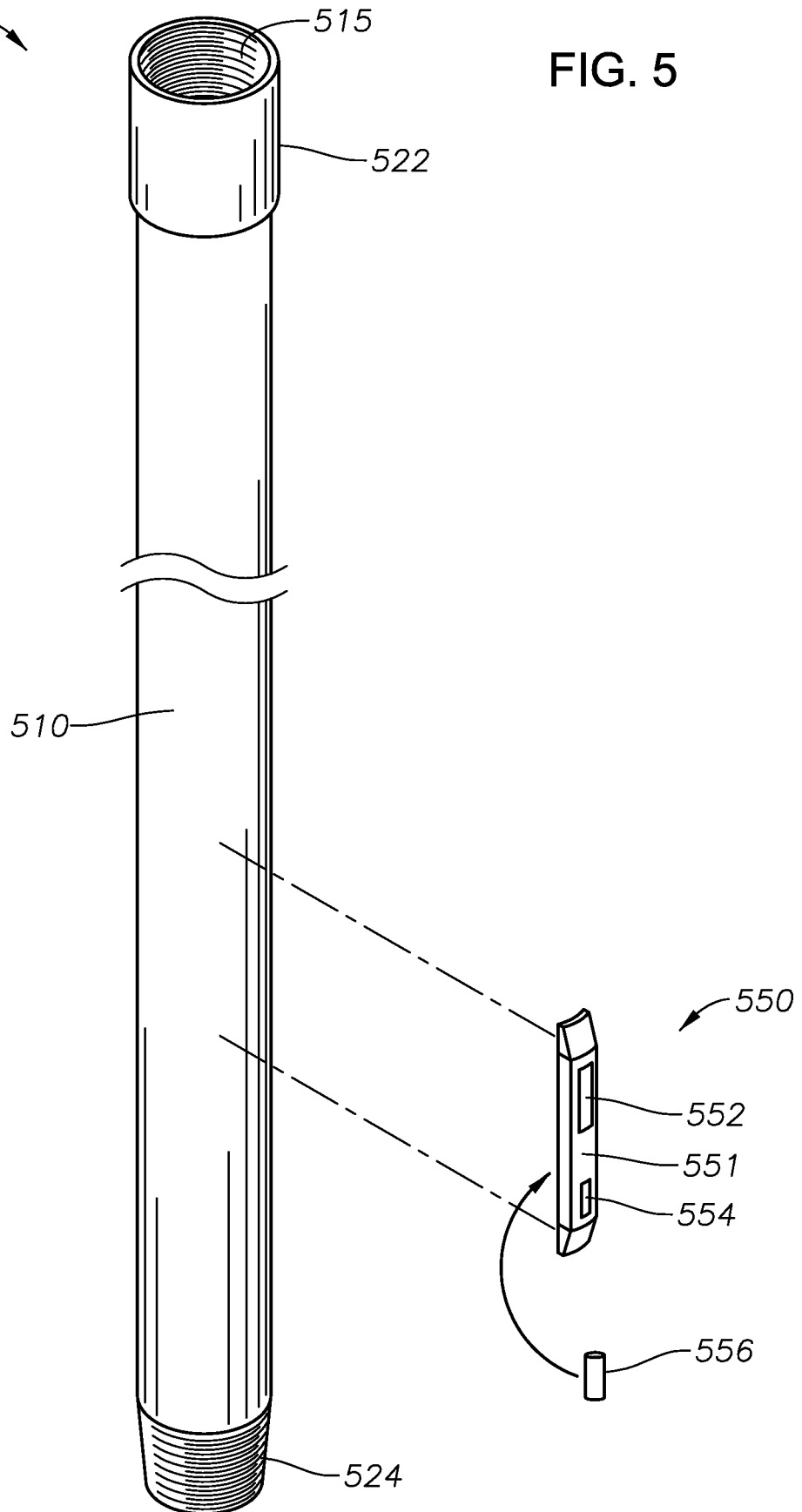

FIG. 4A

6/13

500

FIG. 5



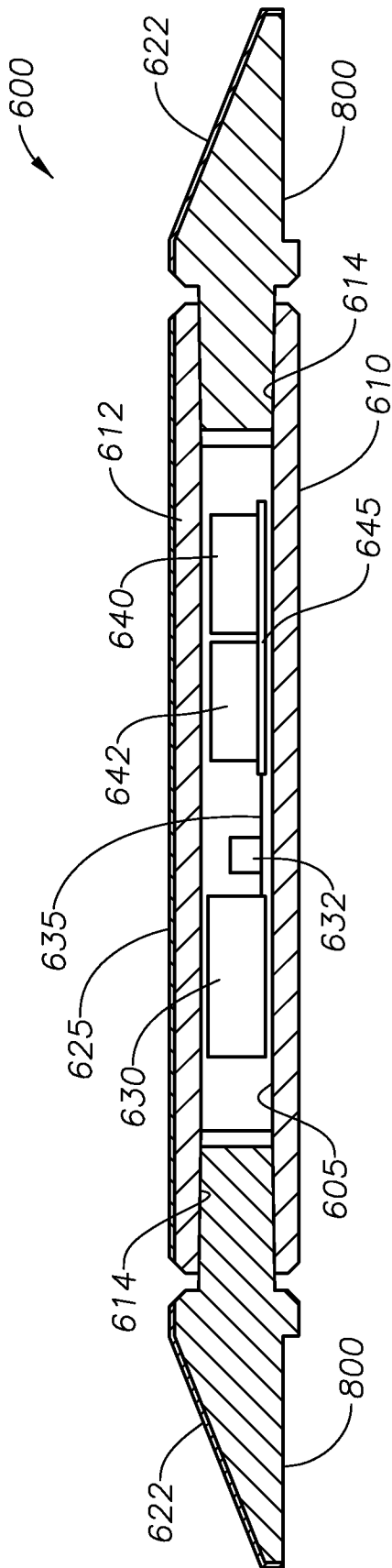

FIG. 6B

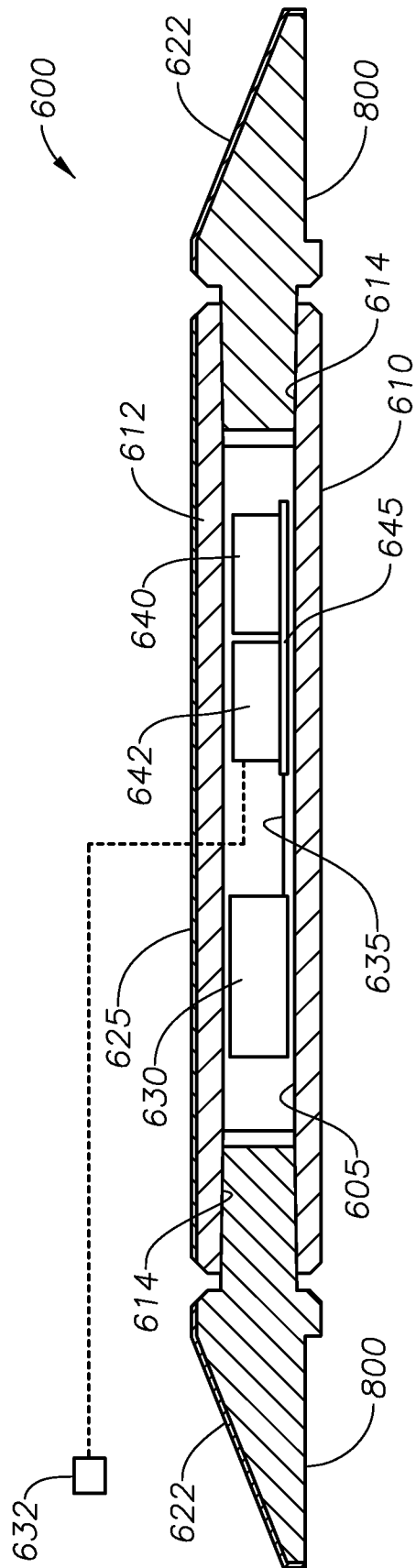

FIG. 6C

8/13

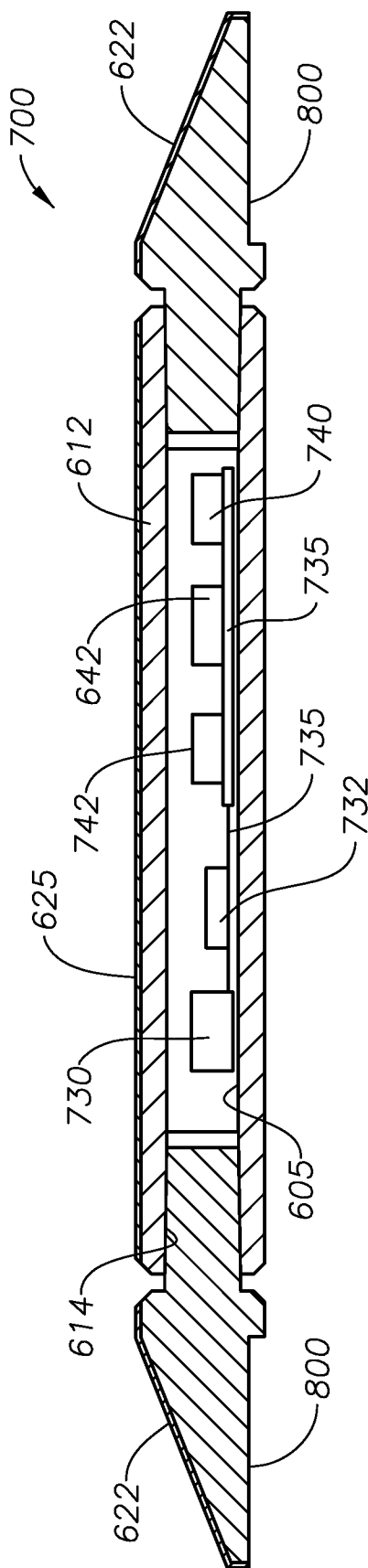

FIG. 7

9/13

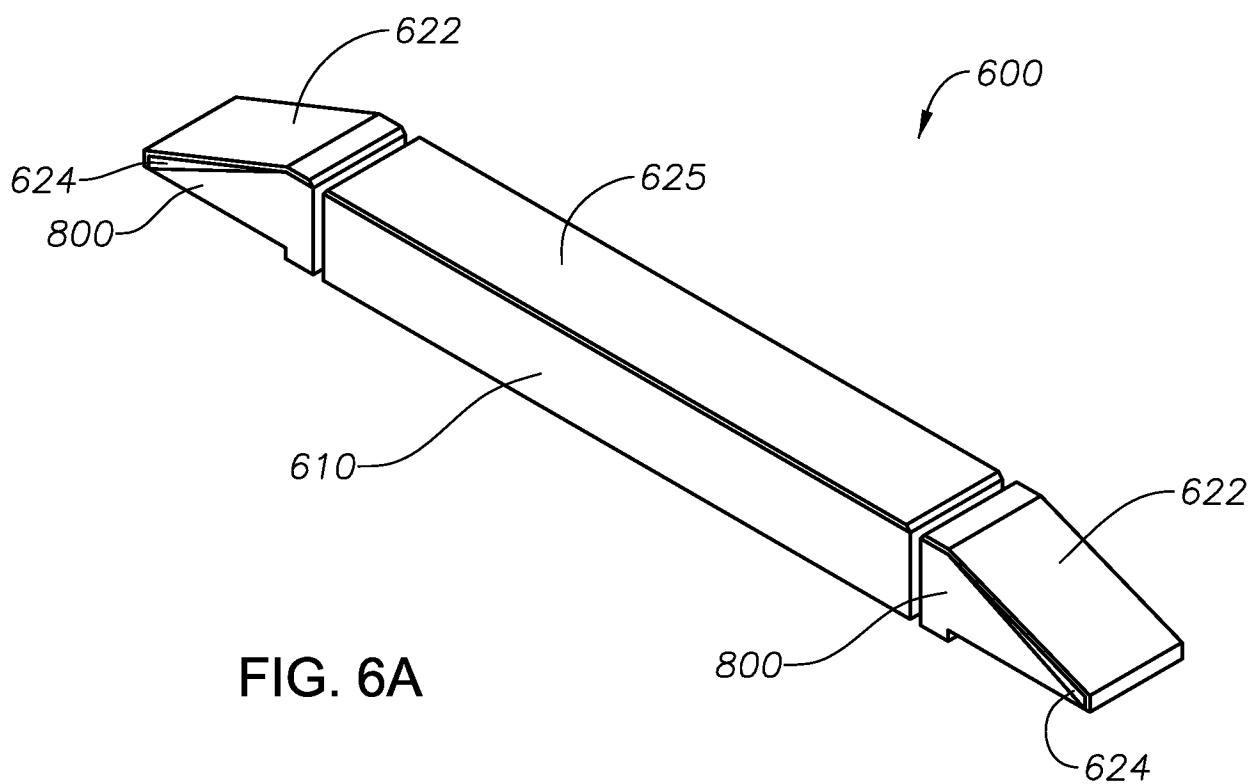

FIG. 6A

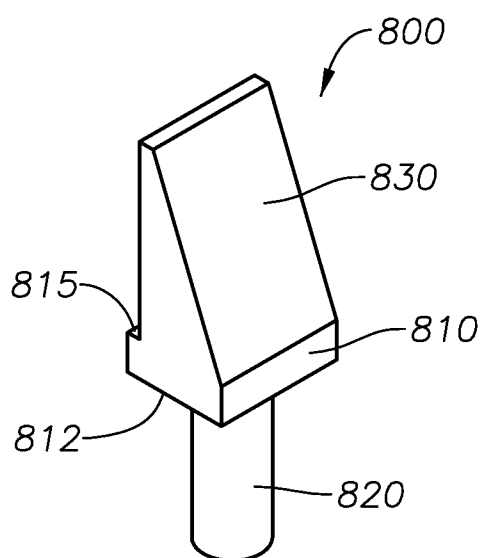

FIG. 8A

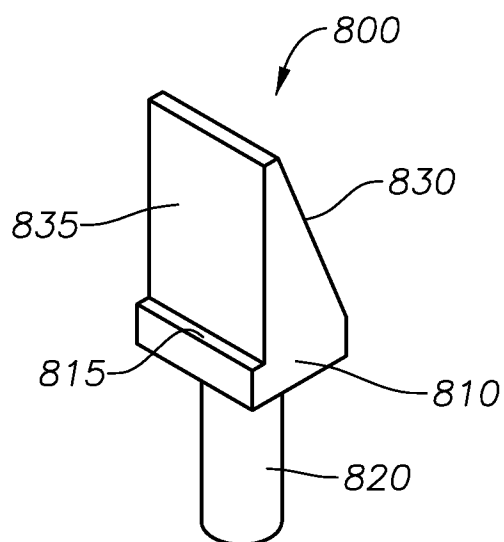

FIG. 8B

10/13

FIG. 9

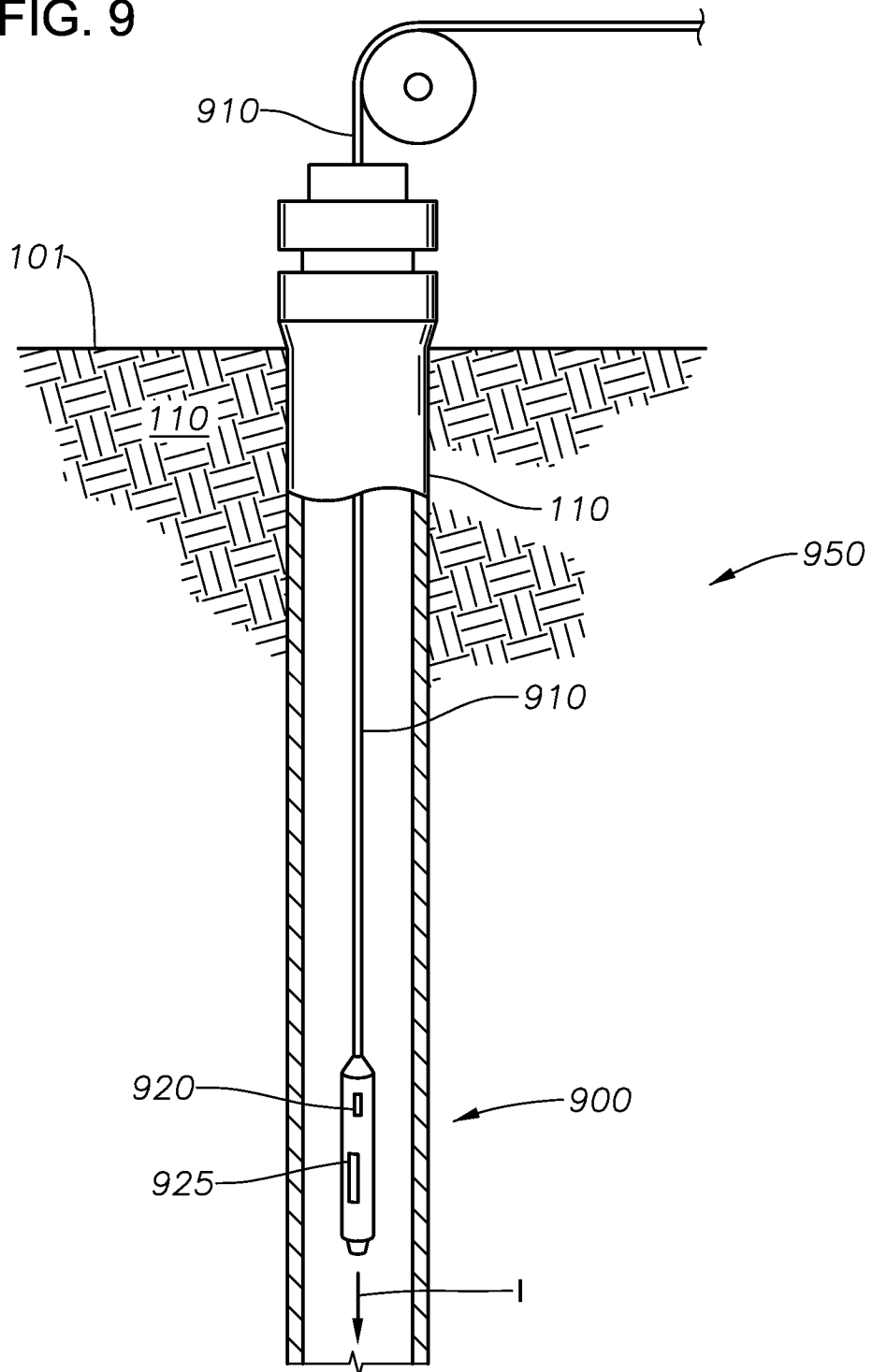

FIG. 10

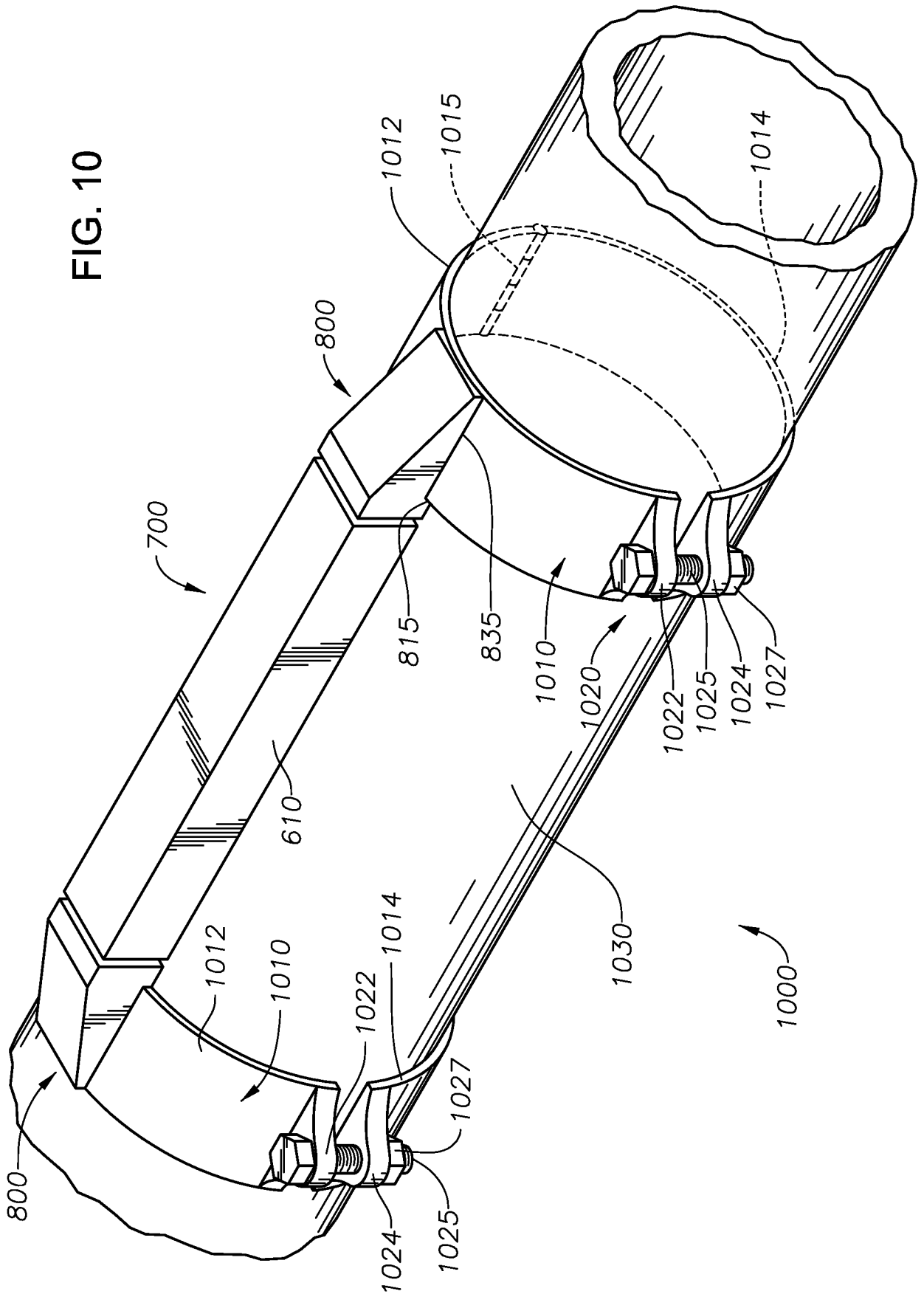
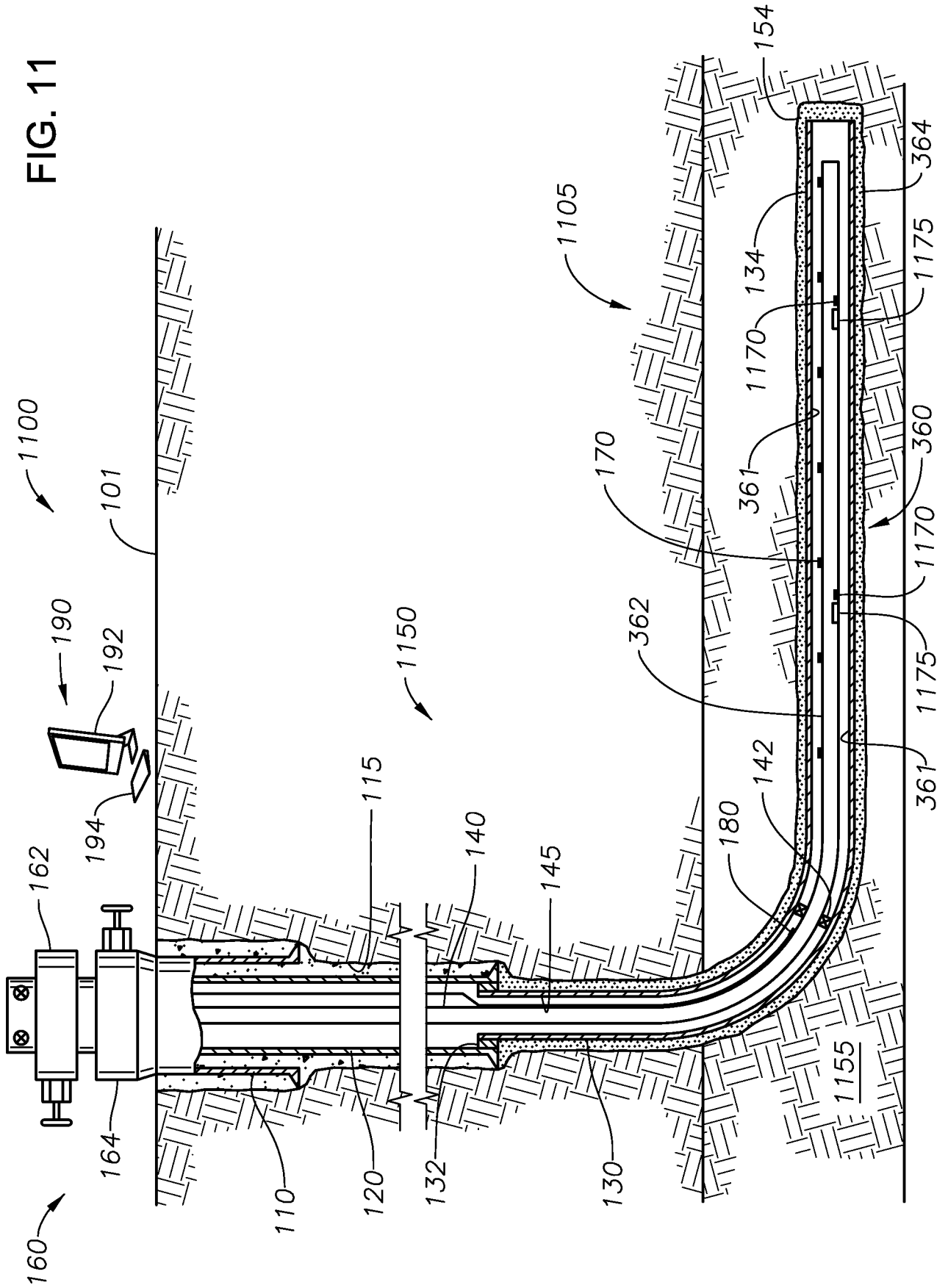



FIG. 11



13/13

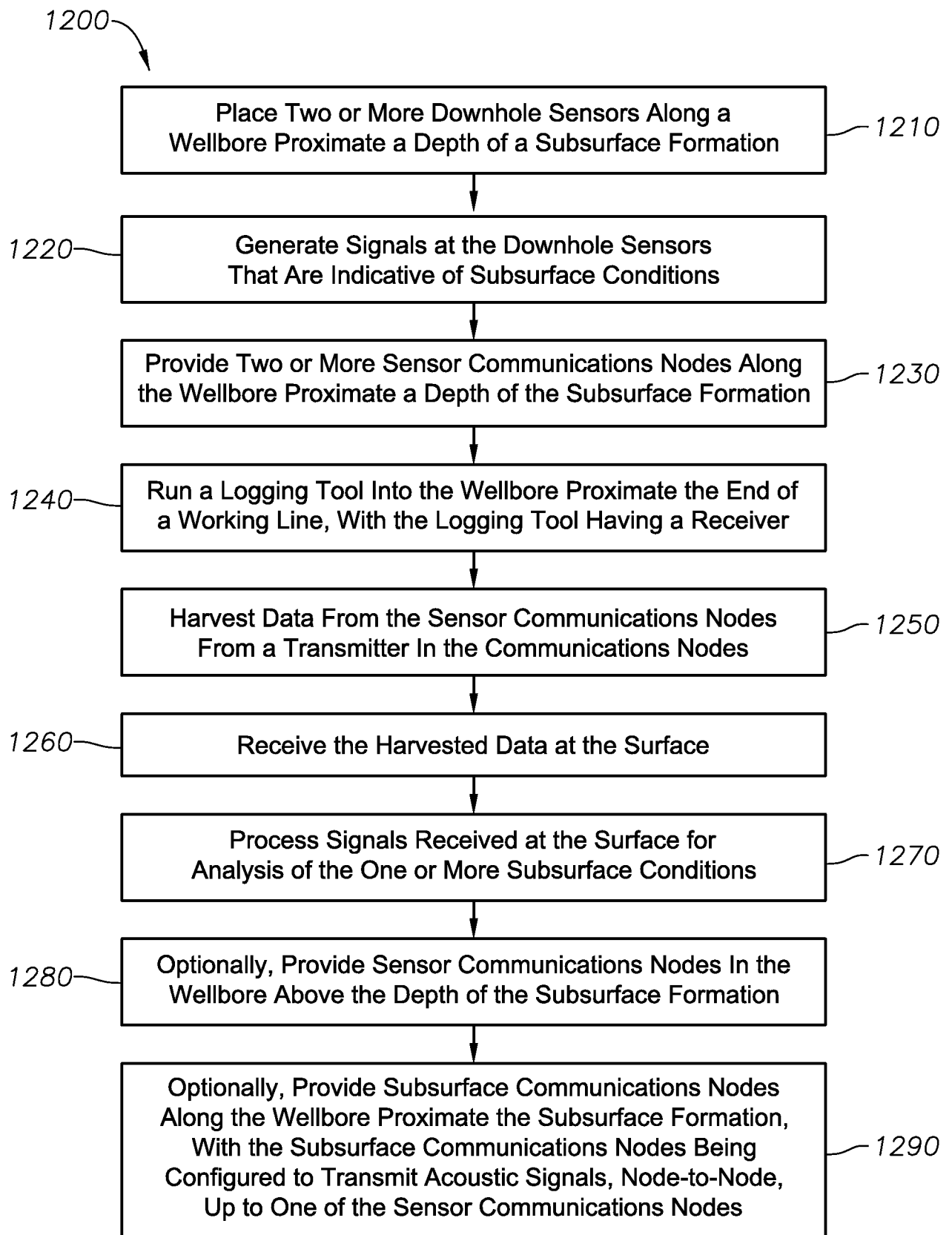

FIG. 12

INTERNATIONAL SEARCH REPORT

International application No.

PCT/US2013/076285

A. CLASSIFICATION OF SUBJECT MATTER

IPC(8) - E21B 47/12 (2014.01)

USPC - 73/152.02

According to International Patent Classification (IPC) or to both national classification and IPC

B. FIELDS SEARCHED

Minimum documentation searched (classification system followed by classification symbols)

IPC(8) - E21B 47/00; 47/06; 47/12; G01N 23/00 (2014.01)

USPC - 73/152.02; 152.05; 152.12; 152.14

Documentation searched other than minimum documentation to the extent that such documents are included in the fields searched

CPC - E21B 47/00; 47/06; 47/12; G01N 23/00 (2013.01)

Electronic data base consulted during the international search (name of data base and, where practicable, search terms used)

Google, Orbit, Google Patents

C. DOCUMENTS CONSIDERED TO BE RELEVANT

Category*	Citation of document, with indication, where appropriate, of the relevant passages	Relevant to claim No.
X	WO 2011/67558 A2 (GODAGER) 09 June 2011 (09.06.2011) entire document	1-6,8,9,14
----		
Y		7,10-13,15-43
Y	WO 2011/110830 A1 (TRIPP et al) 15 September 2011 (15.09.2011) entire document	18-21,23-43
Y	US 2012/0241172 A1 (LUDWIG et al) 27 September 2012 (27.09.2012) entire document	7,27,43
Y	US 2010/0176813 A1 (SIMON) 15 July 2010 (15.07.2010) entire document	10-12,15-17
Y	US 2012/0256415 A1 (DOLE) 11 October 2012 (11.10.2012) entire document	12,31,32
Y	US 2011/0297376 A1 (HOLDERMAN et al) 08 December 2011 (08.12.2011) entire document	13,33
Y	US 6816082 B1 (LABORDE) 09 November 2004 (09.11.2004) entire document	18-21,32, 37-39
Y	EP 0696784 B1 (LIAN) 29 November 2000 (29.11.2000) entire document	18-21,37-39
Y	US 2012/0256492 A1 (SONG et al) 11 October 2012 (11.10.2012) entire document	22
Y	US 5480201 (MERCER) 02 January 1996 (02.01.1996) entire document	32

Further documents are listed in the continuation of Box C.

\* Special categories of cited documents:

"A" document defining the general state of the art which is not considered to be of particular relevance	"T" later document published after the international filing date or priority date and not in conflict with the application but cited to understand the principle or theory underlying the invention
"E" earlier application or patent but published on or after the international filing date	"X" document of particular relevance; the claimed invention cannot be considered novel or cannot be considered to involve an inventive step when the document is taken alone
"L" document which may throw doubts on priority claim(s) or which is cited to establish the publication date of another citation or other special reason (as specified)	"Y" document of particular relevance; the claimed invention cannot be considered to involve an inventive step when the document is combined with one or more other such documents, such combination being obvious to a person skilled in the art
"O" document referring to an oral disclosure, use, exhibition or other means	"&" document member of the same patent family
"P" document published prior to the international filing date but later than the priority date claimed	

Date of the actual completion of the international search 18 March 2014	Date of mailing of the international search report <b>14 APR 2014</b>
--	--

Name and mailing address of the ISA/US Mail Stop PCT, Attn: ISA/US, Commissioner for Patents P.O. Box 1450, Alexandria, Virginia 22313-1450 Facsimile No. 571-273-3201	Authorized officer: Blaine R. Copenheaver PCT Helpdesk: 571-272-4300 PCT OSP: 571-272-7774
---	---