

(12) **UK Patent Application** (19) **GB** (11) **2 323 330** (13) **A**

(43) Date of A Publication **23.09.1998**

(21) Application No 9803259.2	(51) INT CL ⁶ B42D 15/10
(22) Date of Filing 16.02.1998	(52) UK CL (Edition P) B6A AK
(30) Priority Data (31) 9705788 (32) 20.03.1997 (33) GB	(56) Documents Cited US 5362106 A
(71) Applicant(s) Bowater Business Forms Limited (Incorporated in the United Kingdom) First Avenue, Bespoke Division, Westfield Trading Estate, Midsomer Norton, BATH, Avon, BA3 4AP, United Kingdom	(58) Field of Search UK CL (Edition P) B6A AK INT CL ⁶ B42D 15/10
(72) Inventor(s) Paul Shepherd	
(74) Agent and/or Address for Service Mewburn Ellis York House, 23 Kingsway, LONDON, WC2B 6HP, United Kingdom	

(54) Abstract Title
Stationery web with removable identity card

(57) To provide a paper web 10 with a portion which can be peeled away to serve as an identity card, a piece of plastic film 16 is permanently bonded 14 to a portion of the web which is slightly larger than the intended card. Dry peel adhesive 18 is then printed onto the rear face of the film 16 leaving edge portions uncovered to provide peel initiation sites. Backing paper 20 is applied over the film 16 and the card is delimited by a die cut 26 extending through the web and the film but not through the backing paper.

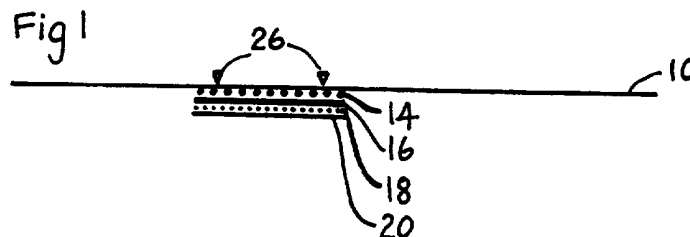

GB 2 323 330 A

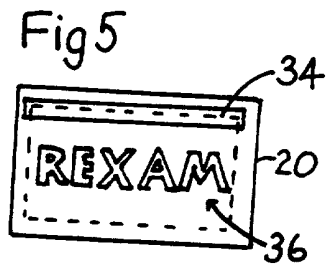
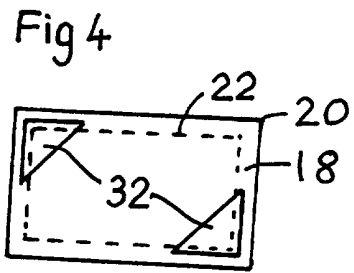
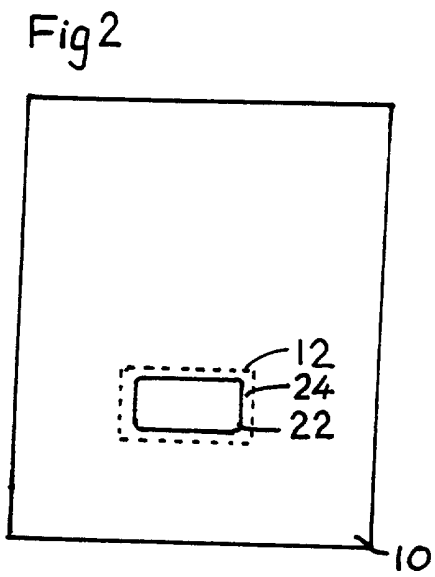
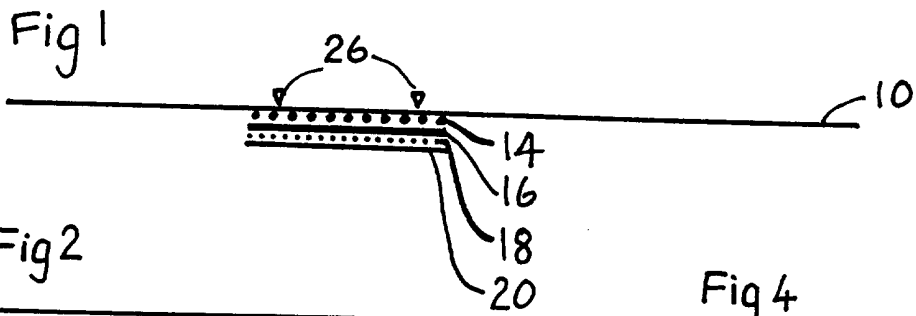
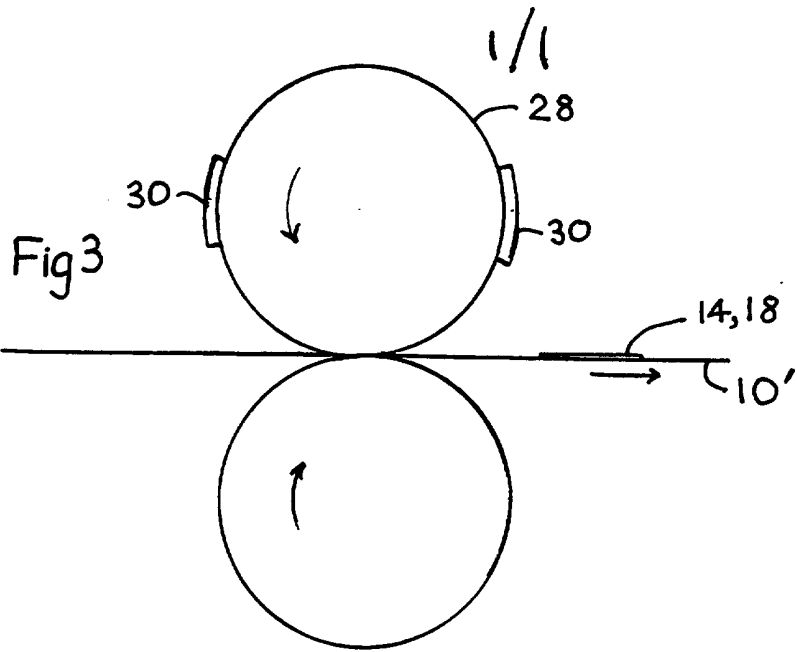

IDENTITY CARDS

The present invention relates to identity cards and similar items (such as membership cards and credit cards), particularly when provided as parts of forms. A known method of manufacturing such forms involves the use of preformed rolls of a special multilayer construction, for example those commercially available under the trade mark FOFIPLAST. This material has five layers: (i) a removable protective sheet; (ii) permanent adhesive; (iii) clear plastic film; (iv) dry peel adhesive; and (v) a backing sheet. This is used to provide a sheet of ordinary continuous stationery with a portion constituting a removable card. For this purpose, a piece of the protective sheet slightly larger than a card is cut from the roll. It is then adhered to the rear face of the stationery sheet using the permanent adhesive, after removal of the protective sheet. The assembly is then die cut, in register with the applied patch of the multilayer material. The cut defines the card. It extends through the stationery sheet and the plastic film, but stops short of the backing sheet. The cut is smaller than the adhered piece so that there is a peripheral band of the piece adhered to the stationery sheet around the cut. Within the cut, there is a cut-out portion of the stationery sheet which is bonded by the permanent adhesive to a corresponding cut-out piece of

the plastic film. This constitutes a separable card, which can be peeled away from the backing sheet.

Sometimes it has been found to be difficult to get hold of an edge portion of a card to start the peeling away. To reduce this problem, it is also known to provide rolls of the multilayer material in which the dry peel adhesive has been applied as bands, of widths slightly less than an intended card width, separated by narrow bands without adhesive. The intention is that is is cut within the narrow bands, leading to a mounted card having regions adjacent the two long edges where there is no dry peel adhesive.

This prior art technique had various disadvantages. The multilayer material is quite expensive to buy. Furthermore, the system is rather inflexible. It is not really possible to produce "customised" material to meet a particular need (unless a very large volume of that particular "customised" type is required, which is unlikely). If the material is of the "easy release" type, with narrow bands lacking dry peel adhesive, then the variation that a user can achieve is even more limited, since the spacing of the bands determines the width of the cards.

In a first aspect, the present invention provides a method of producing a paper web with a removable card element which comprises: (a) adhering a piece of plastic film to a predetermined minor portion of a rear face of a

paper web; (b) subsequently applying dry peel adhesive to
at least part of the exposed rear face of the film; (c)
applying a piece of backing paper to the dry peel
adhesive on said rear face; and (d) cutting from the
5 front face of the web to delimit a card element within
said minor portion, the cut extending through the paper
web and the film but not fully cutting the backing paper.

Preferably said step (b) of applying dry peel
adhesive employs a printing technique, e.g. applying the
10 adhesive by means of a printing cylinder, preferably
using a rubber stereo. Use of a printing technique makes
it easy to apply a desired shape to a desired location,
e.g. in register with existing printing or printing to be
added subsequently. The shape may be such as to
15 facilitate removal of the card element, e.g. leaving
areas such as corner regions of the card element without
adhesive. It is also easy and cheap to carry out
"customised" adhesive application, e.g. using the
adhesive to print indicia (e.g. a logo and/or one or more
20 words or characters). The effect may be enhanced by
using coloured adhesive.

The step (a) of adhering a piece of plastic film may
comprise a preliminary step of applying pressure-
sensitive adhesive to the predetermined minor portion of
25 the rear face of the paper web, followed by a step of
applying the piece of plastic film thereto. The step of
applying the pressure-sensitive adhesive may also be

carried out by a printing technique, e.g. using a printing cylinder, preferably using a rubber stereo. It is commonplace to subject a paper web to several printing steps in register, and thus there is no difficulty in ensuring that the difference steps of the present method produce their effects in register. Step (b) could involve more elaborate printing, e.g. involving two printing steps using difference colours of adhesive, or one step using adhesive and another step using ink.

10 In a second aspect, the present invention provides a paper web incorporating a removable card element as producible by the above method, the paper web having a piece of plastic film and a piece of backing paper adhered to a minor portion of its rear face in register with each other, with the backing paper being adhered by dry peel adhesive; wherein the dry peel adhesive has been applied by a printing technique so as to leave one or more discrete areas void of adhesive to provide one or more indicia; and/or one or more void areas adjacent an edge of the card, and not extending fully across the backing paper, for facilitating peeling.

An embodiment of the present invention will now be described in more detail with reference to the accompanying drawings, in which:

25 Fig. 1 is a schematic side elevation of a paper web as produced by a method embodying the invention;

Fig. 2 is a front view of the web of Fig. 1;

Fig. 3 is a schematic view of the process of applying dry peel adhesive to produce the web shown in Figs. 1 and 2; and

5 Figs. 4 and 5 are top views of backing sheets of embodiments of the invention.

Fig. 1 shows a sheet 10 of paper (which may be, or have been, part of a continuous stationery web). The face which is the underside in Fig. 1 (and will generally be the back face) has had several layers applied to a small portion of it. This portion will typically be substantially rectangular, as shown for the portion 12 in Fig. 2. In the manufacture of the assembly shown in Fig. 1, first a layer 14 of pressure-sensitive adhesive was applied to the area 12. A slightly larger patch 16 of plastic film was cut from a sheet of plastic film, and applied to the pressure-sensitive adhesive. (The film patch 16 is slightly oversize to provide registration tolerances, to ensure that the adhesive 14 is fully covered.) Next, a layer of dry peel adhesive 18 was applied to the back of the film 16. Finally, a piece of backing paper 20 (e.g. glassine paper) was applied to the rear of the layer of dry peel adhesive 18. The assembly was then die-cut from the front to produce a complete, substantially rectangular, peripheral cut 22 slightly smaller than the area of the applied layers 14,16,18,20. Thus as can be seen in Fig. 2, there is a marginal region 24 surrounding the cut 22. The cutting blade 26 is shown

schematically in Fig. 1. (Of course the die cut could define any desired shape, e.g. a circle).

5 The dry peel adhesive 18 (and possibly also the pressure-sensitive adhesive 14) is applied by a printing technique, using a rubber stereo. This is shown schematically in Fig. 3. The illustrated plate cylinder 28 has a circumference of 24 inches (60 cm). In order to produce forms depth 12 inches (30 cm), two rubber sheets 30 are secured to the surface of the cylinder 28, at
10 diametrically opposite locations. (It is simple to produce forms of other sizes such that the length of an integral number equals the circumference of the cylinder 28. For example with the 24 inch cylinder, 8 inch forms would be produced using a cylinder with three equally-
15 spaced rubber sheets 30. Cylinders of other sizes, e.g. 20 inch (50cm), may also be used. The rubber sheets 30 each have the shape and size of the intended patch of adhesive to be applied. It is also a simple matter, by conventional techniques, to adapt the rubber plates so
20 that they do not apply adhesive over the entire (generally rectangular) area, but leave patches of paper uncoated.

Fig. 3 shows a continuous web 10 of paper being "printed". It would subsequently be cut into form
25 lengths. Alternatively the "printing" may be applied to individual sheets.

Fig. 4 is a view showing a piece of release paper 20

and the overlying layer of dry peel adhesive 18. The location of the die cut 22 is also shown. In this example, the dry peel adhesive 18 has been applied to the entire area 12, except for a pair of small corner areas 32 which have been left uncoated. Thus by flexing the paper sheet 10, it is very easy for an end user to grasp a corner of the card element (consisting of the cut out portions of the paper 10 and plastic film 16, and the pressure-sensitive adhesive bonding them permanently together), and peel it free from the underlying backing sheet.

Fig. 5 is a similar view showing a backing sheet 20 having a marginal strip portion 34 which has been left free from adhesive to provide easy release. Furthermore, Fig. 5 shows areas 36 left free from adhesive in a central area so as to define indicia (in this case, the word REXAM). Since the indicia 36 are applied by a conventional printing technique, it can easily be ensured that they are in register with the opening produced by the removal of the card element. Furthermore it is a simple and economical matter to produce a new rubber stereo 30 with any desired indicia. This can be done economically for quite short runs. The dry peel adhesive 18 may be tinted, so that the adhesive-free indicia 36 are clearly visible. The printing of indicia or images need not involve areas devoid of adhesive. The adhesive may be screened. If different areas are screened with

different densities/dot frequencies, images appearing lighter or darker than the background can be produced.

CLAIMS

1. A method of producing a paper web with a removable card element which comprises: (a) adhering a piece of plastic film to a predetermined minor portion of a rear
5 face of a paper web; (b) subsequently applying dry peel adhesive to at least part of the exposed rear face of the film; (c) applying a piece of backing paper to the dry peel adhesive on said rear face; and (d) cutting from the front face of the web to delimit a card element within
10 said minor portion, the cut extending through the paper web and the film but not fully cutting the backing paper.
2. A method according to claim 1 wherein said step (b) of applying dry peel adhesive employs a printing technique.
- 15 3. A method according to claim 2 wherein said printing technique employs a rubber stereo.
4. A method according to claim 2 or claim 3 wherein said adhesive is applied in a pattern by printing through a screen.
- 20 5. A method according to claim 2, 3 or 4 including a step of printing indicia, and wherein said application of adhesive by a printing technique is carried out so as to be in register with existing printed indicia or printed indicia which are added subsequently.
- 25 6. A method according to any preceding claim wherein said dry peel adhesive is applied so as to leave areas of the card element without adhesive, thus facilitating

removal of the card element.

7. A method according to any preceding claim wherein the step (a) of adhering a piece of plastic film comprises a preliminary step of applying pressure-

5 sensitive adhesive to the predetermined minor portion of the rear face of the paper web, followed by a step of applying the piece of plastic film thereto.

8. A method according to claim 7 wherein the step of applying the pressure-sensitive adhesive is carried out
10 by a printing technique.

9. A method of producing a paper web with a removable card element substantially as herein described with reference to and as illustrated in the accompanying drawings.

15 10. A paper web incorporating a removable card element as producible by the method of any preceding claim, the paper web having a piece of plastic film and a piece of backing paper adhered to a minor portion of its rear face in register with each other, with the backing paper being
20 adhered by dry peel adhesive; wherein the dry peel adhesive has been applied by a printing technique so as to leave one or more discrete areas void of adhesive to provide one or more indicia; and/or one or more void areas adjacent an edge of the card, and not extending
25 fully across the backing paper, for facilitating peeling.



Application No: GB 9803259.2
Claims searched: 1-10

Examiner: Graham Russell
Date of search: 16 June 1998

**Patents Act 1977
Search Report under Section 17**

Databases searched:

UK Patent Office collections, including GB, EP, WO & US patent specifications, in:

UK Cl (Ed.P): B6A (AK)

Int Cl (Ed.6): B42D 15/10

Other:

Documents considered to be relevant:

Category	Identity of document and relevant passage	Relevant to claims
A	US 5362106 (MOORE BUSINESS FORMS) see Fig 2 and column 3 lines 49-65	1

X Document indicating lack of novelty or inventive step
Y Document indicating lack of inventive step if combined with one or more other documents of same category.
& Member of the same patent family

A Document indicating technological background and/or state of the art.
P Document published on or after the declared priority date but before the filing date of this invention.
E Patent document published on or after, but with priority date earlier than, the filing date of this application.