

(21) Application No: **0226242.6**

(22) Date of Filing: **11.11.2002**

(71) Applicant(s):
QinetiQ Limited
(Incorporated in the United Kingdom)
Registered Office, 85 Buckingham Gate,
LONDON, SW1E 6PD, United Kingdom

(72) Inventor(s):
Andrew Charles Lewin
David Arthur Orchard
Simon Christopher Woods

(74) Agent and/or Address for Service:
QinetiQ Limited
IP Formalities, A4 Building, Room G016,
Cody Technology Park, Ively Road,
FARNBOROUGH, Hants, GU14 0LX,
United Kingdom

(51) INT CL⁷:
G01B 11/14

(52) UK CL (Edition W):
G1A AA2 AEY AR7

(56) Documents Cited:
GB 2372656 A **US 6154279 A**
US 4294544 A

(58) Field of Search:
UK CL (Edition V) **G1A, H4D**
INT CL⁷ **G01B, G01S**
Other: **Online: WPI, EPODOC, PAJ**

(54) Abstract Title: **Ranging apparatus**

(57) This invention relates to a ranging apparatus capable of ranging simultaneously to a two dimensional scene. An illumination means (22) illuminates a scene with a two dimensional array of spots (12). A detector (6) is located near to the illumination means (22) and arranged to look toward the scene. A processor (7) responds to the output from the detector (6) and, from the location of a spot in the scene, determines the range to that spot. A variety of techniques are used to resolve ambiguity in determining which projected spot is being considered.

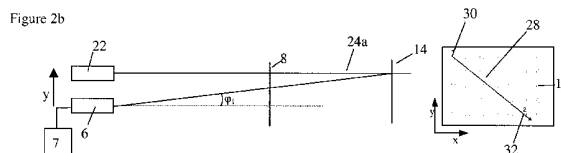
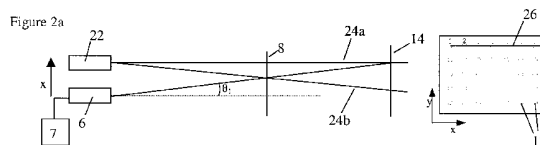

At least one drawing originally filed was informal and the print reproduced here is taken from a later filed formal copy.

This print takes account of replacement documents submitted after the date of filing to enable the application to comply with the formal requirements of the Patents Rules 1995

Original Printed on Recycled Paper

Figure 1a

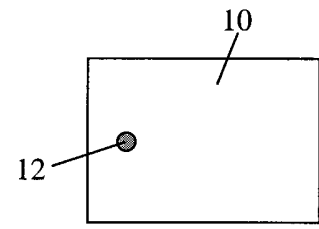
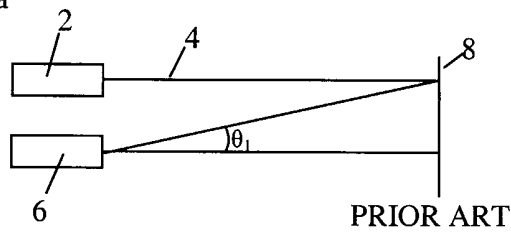

Figure 1b

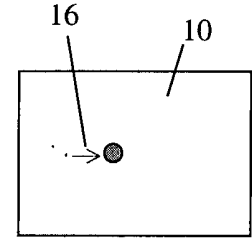
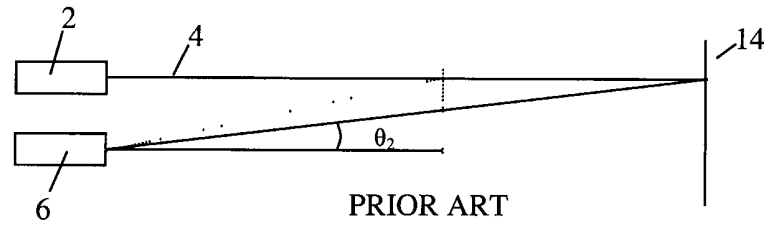

Figure 2a

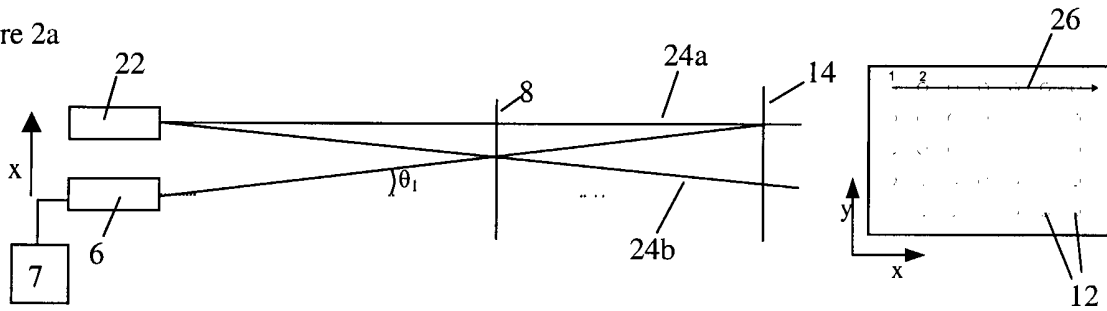

Figure 2b

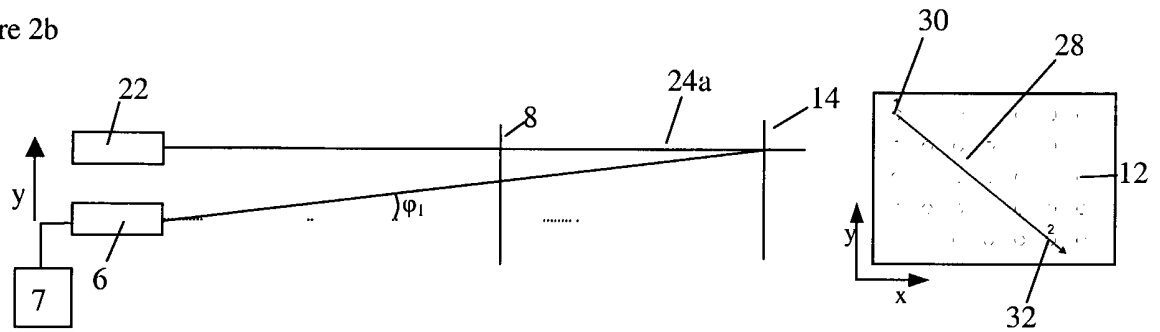

Figure 3

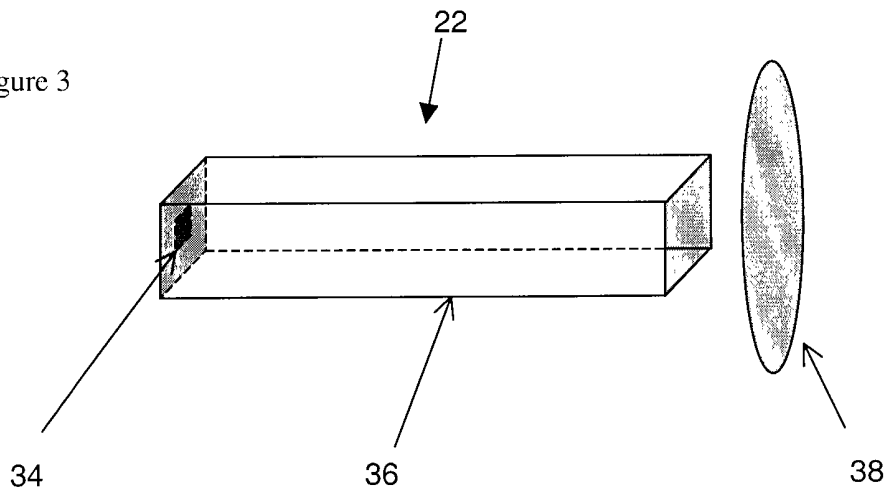
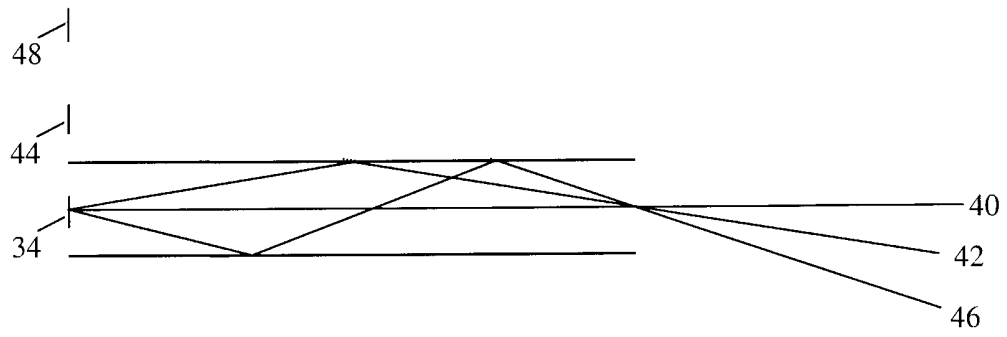

Figure 4



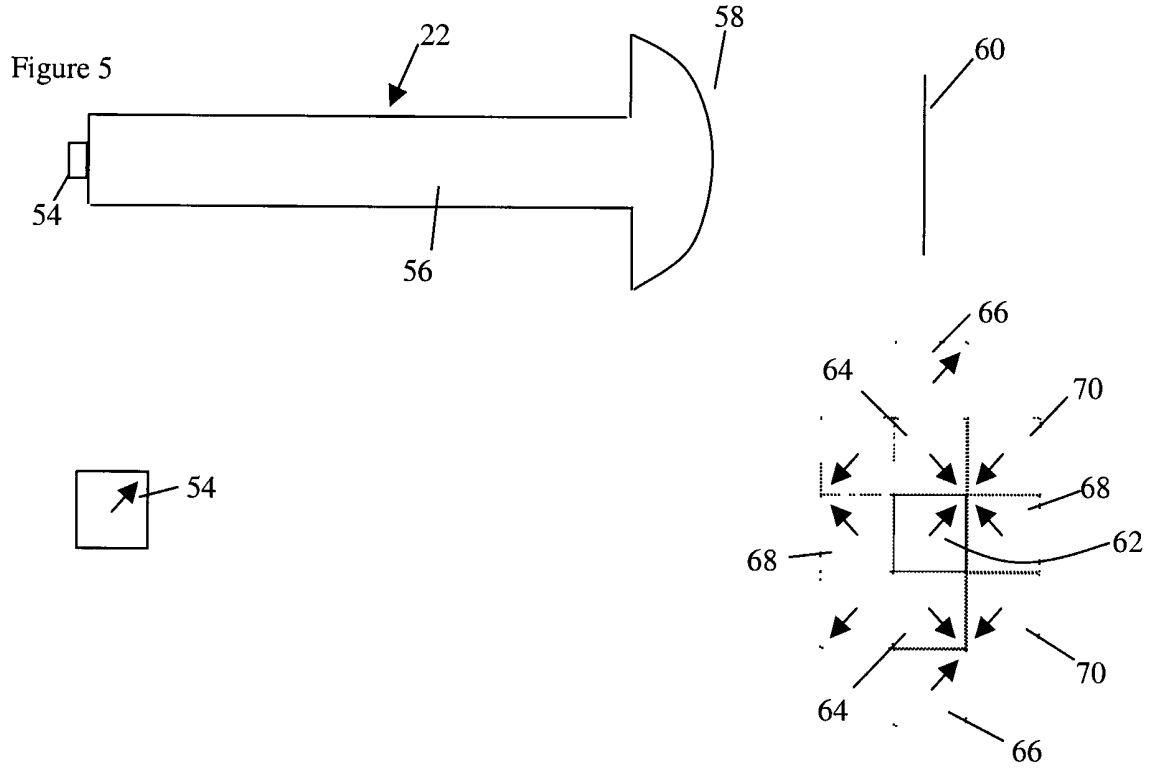

Figure 6

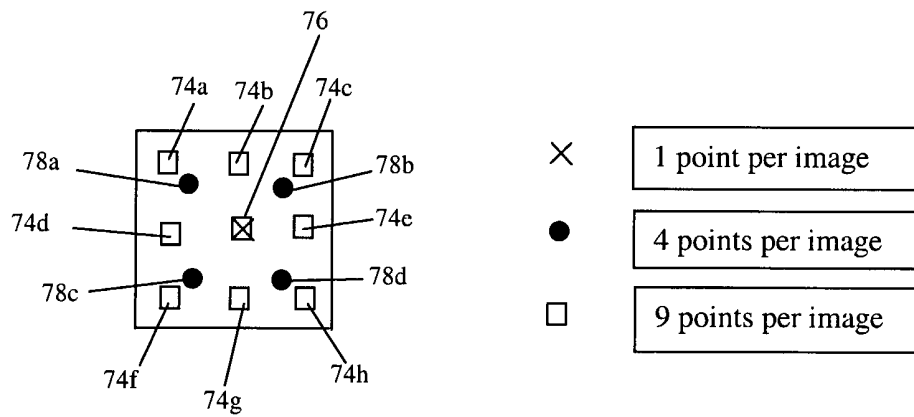

Figure 7

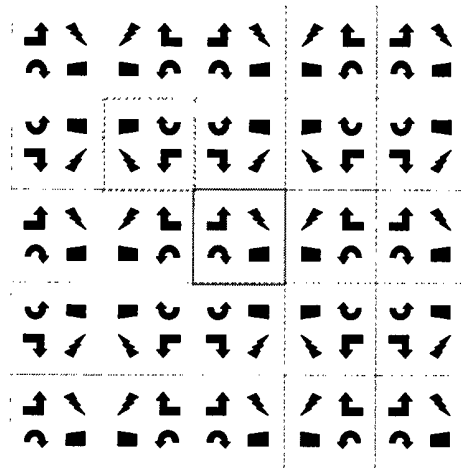
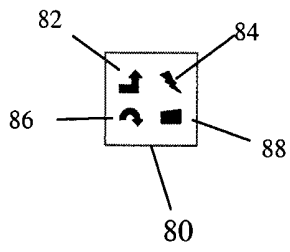

Figure 8

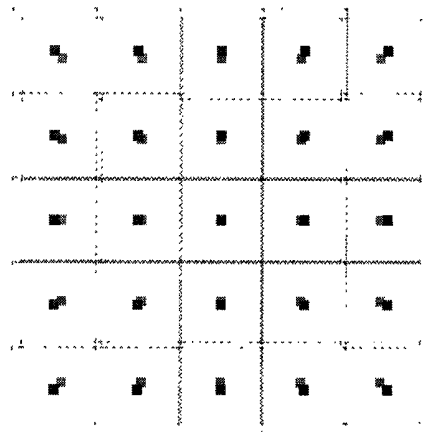
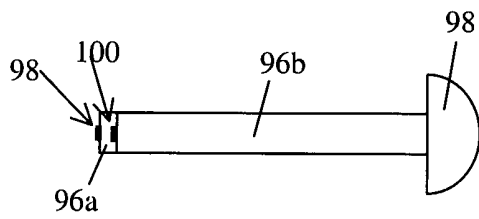
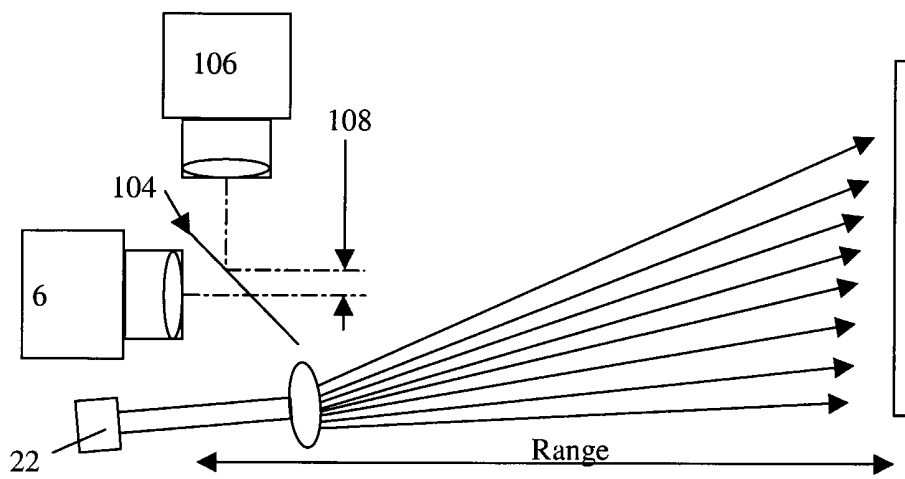
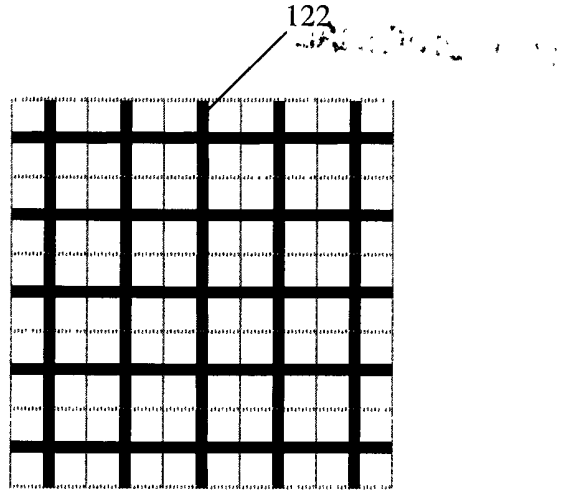
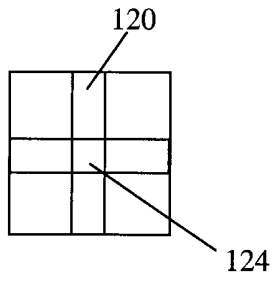

Figure 9



10 10 00

Figure 10



Ranging Apparatus

This invention relates to a range finding apparatus, especially to an imaging range finding apparatus.

5

Imaging range finding systems often illuminate a scene and image the light reflected from the scene to determine range information.

One known system, a so called triangulation system, uses a source arranged to
10 illuminate a scene with a beam of light such that a spot appears in the scene. A detector is oriented in a predetermined fashion with respect to the source such that the position of the spot of light in the scene reveals range information. The beam of light may be scanned in both azimuth and elevation across the scene to generate range information from across the whole scene. In some systems the beam of light may be a
15 linear beam such that one dimensional range information is gathered simultaneously and the linear beam scanned in a perpendicular direction to gain range information in the other dimension.

Triangulation systems are not known however that can take range measurements in
20 two dimensions from the scene simultaneously. The need for scanning adds to the cost and complexity and also means that accurate ranging is not possible with fast changing scenes. Further the illumination in known triangulation systems often requires laser systems. Use of laser systems may have safety implications and can require complicated and relatively expensive scanning mechanisms. Lasers are also
25 relatively high power sources.

An alternative ranging system is described in US patent 6,377,353. Here a light source is arranged in front of a patterned slide which has an array of apertures therein. Light from the source only passes through the apertures which therefore projects an
30 array of spots onto the scene. The range information in this apparatus is determined by analysing the size and shape of the spots formed. This system requires the size of the spots and orientation thereof to be determinable however which requires reasonable differences in spot size. The system necessarily therefore has a limited

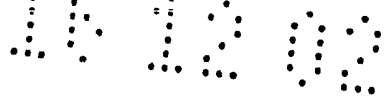

depth of view and is only really usable for ranging to continuous surfaces such as animals.

5 It is therefore an object of the present invention to provide a ranging apparatus that mitigates at least some of the above mentioned disadvantages.

Therefore according to the present invention there is provided a ranging apparatus comprising an illumination means for illuminating a scene with a two dimensional array of light spots, a detector for detecting the location of spots in the scene and a
10 processor adapted to determine, from the detected location of a spot in the scene, the range to that spot.

The illumination means illuminates the scene with an array of spots. The detector then looks at the scene and the processor determines the location of spots in the
15 detected scene. The apparent location of any spot in the array will change with range due to parallax. As the relationship of the detector to the illuminations means is known the location in the scene of any known spot in the array can yield the range to that point.

20 Of course, to be able to work out the range to a spot it is necessary to know which spot in the array is being considered. In the prior art single spot systems there is only one spot in the scene and so there is no difficulty. Even when using a linear beam the beam is projected so as to be parallel to one direction, say the y-direction. For each value in the y-direction then the actual x-position in the scene can then be used to
25 determine the range.

Prior to the present invention the skilled person would not have thought of using a two dimensional array of spots as they would have thought that this would have meant that the ranging system would either be unable to determine which spot was which
30 and hence could not perform ranging or would produce a result that could suffer from errors if the wrong spot had been considered. The present invention however does allow use of a two dimensional array of spots for simultaneous ranging of a two-dimensional scene and uses various techniques to avoid ambiguity over spot determination.

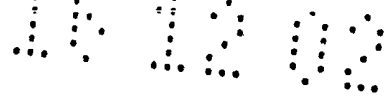

As used herein the term array of spots is taken to mean any array which is projected onto the scene and which has distinct areas of intensity. Generally a spot is any distinct area of high intensity radiation and may, as will be described later, be adapted to have a particular shape. The areas of high intensity could be linked however provided that the distinct spot can be identified. For instance the illumination means may be adapted to project an array of intersecting lines onto the scene. The intersection of the lines is a distinct point which can be identified and is taken to be a spot for the purposes of this specification.

10

Conveniently the illumination means and detector are arranged such that each spot in the projected array appears to move in the detected scene, from one range to another, in a direction parallel to a first axis and each adjacent spot in the projected array is a different perpendicular distance from the first axis. As will be explained later each spot in the array will appear at a different point in scene depending upon the range to the target. If one were to imagine a flat target slowly moving away from the detector each spot would appear to move across the scene. This movement would be in a direction parallel to the axis joining the detector and illumination means, assuming no mirrors etc. were placed in the optical path of the detector or illumination means.

15

Each spot would however keep the same location in the scene in the direction perpendicular to this axis.

20

Each projected spot could therefore be said to have a locus corresponding to possible positions in the scene at different ranges within the operating range. The actual position of the spot in the detected scene yields the range information. As mentioned the loci corresponding to different spots in the projected array may overlap, in which case the processor would not be able to determine which spot in the projected array is being considered. Were the loci of spots which are adjacent in the projected array to overlap, measurement of the location in the scene of a particular spot could correspond to any of a number of different ranges with only small distances between the possible ranges. For example, imagine the array of spots was a two dimensional array of spots in an x-y square grid formation and the detector and illumination means were spaced apart along the x-axis only. Using cartesian co-ordinates to identify the spots in the projected array with (0,0) being the centre spot and (1,0) being one spot

25

30

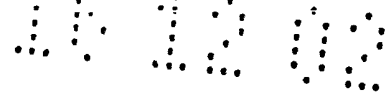

along the x-axis, the location in the scene of the spot at position (0,0) in the projected array at one range might be the same as the position of projected spot (1, 0) at another slightly different range or projected even spot (2,0) at a slightly different range again. The ambiguity in the scene would therefore make range determination
5 difficult.

Were however the detector and illumination means arranged such that the axis between them was not parallel to either the x-axis or the y-axis of the projected array then adjacent spots would not overlap. Ideally the locus of each spot in the projected
10 array would not overlap with the locus of any other spot but in practice with relatively large spots and large arrays this may not be possible. However if the arrangement was such so that the loci of each spot only overlapped with that of a spot relatively far removed in the array then although ambiguity would still be present the amount of ambiguity would be reduced. Further the difference in range between the possible
15 solutions would be quite large. For example the range determined were a particular projected spot, (0,4) say, to be detected at one position in the scene could be significantly different from that determined if a spot removed in the array (5,0) appeared at the same position in the scene. In some applications the operating range may be such that the loci corresponding to the various possible locations in the scene
20 of the spots within the operating window would not overlap and there would be no ambiguity. Even where the range of operation would allow the loci of spots to overlap the significant difference in range could allow a coarse estimation of range to be performed to allow unique determination of which spot was which with the location of each spot in the scene then being used to give fine range information.

25

One convenient way of determining coarse range information involves the illumination means and detector being adapted such that a projected array of spots would appear focussed at a first distance and unfocussed at a second distance, the first and second distances being within the operating range of the apparatus. The
30 processor is adapted to determine whether a spot is focussed or not so as to determine coarse range information. For example if a detected spot could correspond to projected spot (0,4) hitting a target at close range or projected spot (5,0) hitting a target at long range the processor could look at the image of the spot to determine whether the spot is focussed or not. If the illumination means and detector were

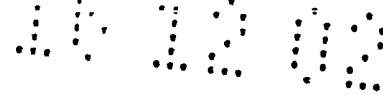

together adapted such that the spots were focussed at long range the determination that the spot in question was focussed would mean that the detected spot would have to be projected spot (5,0) hitting a target at long range. Had an unfocussed spot been detected this would have corresponded to spot (0,4) reflected from a target at close
5 range. Preferably in order to ease identification of whether a spot is focussed or not the illumination means is adapted to project an array of spots which are non-circular in shape when focussed, for instance square. An in focus spot would then be square whereas an unfocussed spot would be circular.

10 As an additional or alternative method of resolving possible ambiguity the illumination means could be adapted to periodically alter the two dimensional array of projected spots, i.e. certain spots could be turned on or off at different times. The apparatus could be adapted to illuminate the scene cyclically with different arrays of spots. In effect one frame could be divided into a series of sub-frames with a sub-
15 array being projected in each sub-frame. Each sub-array would be adapted so as to present little or no range ambiguity in that sub-frame. Over the whole frame the whole scene could be imaged in detail but without ambiguity. This approach has the disadvantage though that imaging may take several sub-frames. An alternative approach could be to illuminate the scene with the whole array of spots and identify
20 any areas of ambiguity. If a particular detected spot could correspond to more than one projected spot at different ranges, one or more of the possible projected spots could then be deactivated so as to resolve the ambiguity. This approach may require more processing but could allow quicker ranging.

25 Additionally or alternatively the illumination means may be adapted to so as to produce an array of spots wherein each projected spot has a different characteristic to its adjacent spots. The different characteristic could be colour or shape or both. Having a different colour or shape of spot again reduces ambiguity in detected spots. Although the loci of different spots may overlap, and there may be some ambiguity
30 purely based on spot location in the scene, if the projected spots giving rise to those loci are different in colour and/or shape the processor would be able to determine which spot was which and there would be no ambiguity. The detector and illumination means are therefore preferably arranged such that if the locus of one

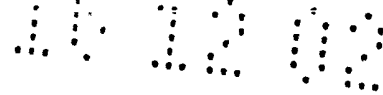

projected spot does overlap with the locus of one or more other projected spots at least the nearest projected spots having a locus in common have different characteristics.

- 5 As mentioned above the spots may comprise intersections between continuous lines. The detector can then locate the spots, or areas where the lines intersect, as described above. Preferably the illumination means projects two sets of regularly spaced lines, the two sets of lines being substantially orthogonal.

- 10 Using intersecting lines in this manner allows the detector to locate the position of the intersection points in the same manner as described above. Once the intersection points have been found and identified the points on the connecting lines can also be used for range measurements as the location in the detected scene of any point on known the line will give the range in the same manner. Thus the resolution of the
- 15 range finding apparatus can be improved over that using only separated spots.

The detector is conveniently a two dimensional CCD array, i.e. a CCD camera. A CCD camera is a relatively cheap and reliable component and has good resolution for spot determination. Other suitable detectors would be apparent to the skilled person

20 however and would include CMOS cameras.

Conveniently the illumination means is adapted such that the two dimensional array of spots are infrared spots. Using infrared radiation means that the spots do not affect the scene in the visible range. The detector may be adapted to capture a visible image

25 of the scene as well as the location of the infrared spots in the scene.

The baseline between the detector and the illumination means determines the accuracy of the system. The term baseline refers to the separation of the line of sight of the detector and the line of sight of the illumination means. As the skilled person will

30 understand the degree of apparent movement of any particular spot in the scene between two different ranges will go up as the separation or baseline between the detector and the illumination means is increased. An increased apparent movement in the scene between different ranges obviously means that the difference in range can

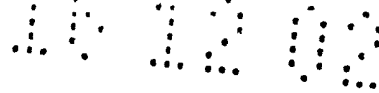

be determined more accurately. However equally an increased baseline also means that the operating range in which there is no ambiguity is also reduced.

5 The baseline between the detector and the illumination means is therefore chosen according to the particular application. For a ranging apparatus intended to work over an operating distance of say 0.5m to 2.0m the baseline of the detector and the illumination means approximately 60mm.

10 It should be noted that the term baseline is not intended to be taken to mean the actual physical separation between the detector and the illumination means. It will refer to the actual physical separation when both the optical path from the illumination means to the scene and the optical path from the scene to the detector are linear. Some embodiments however may use mirrors, beam splitters etc in the optical path of one or both of the illumination means and the scene. In which case the actual physical
15 separation could be large but by use of appropriate optical components the apparent separation or baseline would still be small. For instance the illumination means could illuminate the scene directly but a mirror placed close to the illumination means could direct received radiation to the detector. In which case the actual physical separation could be large but the apparent separation, the baseline, would be determined by the
20 location of the mirror. The skilled person would understand that the term baseline should be taken as referring to the apparent separation between the detector and the illumination means, i.e. the actual separation there would be if the optical paths to or from the detector and illumination means were straight.

25 The detector means may be adapted to image the scene from more than one direction. The detector could be either moveable from one location to another location so as to image the scene from a different viewpoint or scanning optics could be placed in the optical path to the detector so as to periodically redirect the look direction. Both of these approaches require moving parts however and mean that the scene must be
30 imaged over sub-frames. As an alternative the detector may comprise two detector arrays each detector array arranged so as to image the scene from a different direction.

Imaging the scene from more than one direction can have several advantages. Obviously objects in the foreground of the scene may obscure objects in the

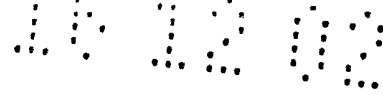

background of the scene from certain viewpoints. Changing the viewpoint of the detector can ensure that range information to the whole scene is obtained. Further the difference between the two images can be used to provide range information about the scene. Objects in the foreground will appear to be displaced between the two
5 images than those in the background. This could be used to give coarse range information. Also, as mentioned, in certain viewpoints one object in the foreground may obscure an object in the background – this can be used to give relative range information. The relative movement of objects in the scene may also give range information. For instance objects in the foreground may appear to move one way in
10 the scene moving from one viewpoint to the other whereas objects in the background may appear to move the other way. The processor therefore preferably applies image processing algorithms to the scenes from each viewpoint to determine range information therefrom. The type of image processing algorithms required would be understood by one skilled in the art. The range information revealed in this way may
15 be used to remove any ambiguity over which spot is which in the scene to allow fine ranging.

If more than one viewpoint is used the viewpoints could be adapted to have different baselines. As mentioned the baseline between the detector and the illumination means
20 has an effect on the range and the degree of ambiguity of the apparatus. One viewpoint could therefore be used with a low baseline so as to give a relatively low accuracy but unambiguous range to the scene over the distances required. This coarse range information could then be used to remove ambiguities from a scene viewed from a viewpoint with a larger baseline and hence greater accuracy.

25 Alternatively the baselines between the two viewpoints could be chosen such that if a spot detected in the scene from one viewpoint could correspond to a first set of possible ranges the same spot detected in another viewpoint could only correspond to one range within that first set. In other words imagine that a spot is detected in the
30 scene viewed from the first viewpoint and could correspond to a first spot (1,0) at a first range R_1 , a second spot (2,0) at a second range R_2 , a third spot (3,0) at a third range R_3 and so on. The same spot could also give a possible set of ranges when viewed from the second viewpoint, i.e. it could be spot (1,0) at range r_1 , spot (2,0) at range r_2 , and so on. When the two sets of ranges are compared it may be that there is

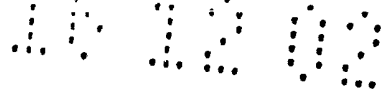

only one possible range common to both sets and this therefore must be the actual range.

5 The apparatus may further comprise a plurality of illumination means arranged to illuminate the scene from different directions, the system being adapted to periodically change the illumination means used to illuminate the scene. Having two illumination means gives some of the same benefits as described above as having two detectors. With one illumination means objects in the background may be in the shadow of objects in the foreground and hence will not be illuminated by the illumination means. Therefore it would not be possible to generate any range information. Having two illumination means could avoid this problem. Further if the detector or detectors were at different baselines from the various illumination means the differing baselines could again be used to help resolve range ambiguities.

15 The illumination means should ideally use a relatively low power source and produce a large regular array of spots with a large depth of field. A large depth of field is useful when working with a large operating window of possible ranges.

20 In a preferred embodiment therefore the illumination means comprises a light source arranged to illuminate part of the input face of a light guide, the light guide comprising a tube having substantially reflective sides and being arranged together with projection optics so as to project an array of distinct images of the light source towards the scene. The light guide in effect operates as a kaleidoscope. Light from the source is reflected from the sides of the tube and can undergo a number of reflection paths within the tube. The result is that multiple images of the light source are produced and projected onto the scene. Thus the scene is illuminated with an array of images of the light source. Where the source is a simple light emitting diode the scene is therefore illuminated with an array of spots of light.

30 The light guide comprises a tube with substantially reflective walls. Preferably the tube has a constant cross section which is conveniently a regular polygon. Having a regular cross section means that the array of images of the light source will also be regular which is advantageous for ensuring the whole scene is covered and eases processing. A square section tube is most preferred.

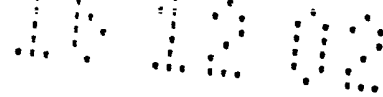

The tube may comprise a hollow tube having reflective internal surfaces, i.e. mirrored internal walls. Alternatively the tube may be fabricated from a solid material and arranged such that a substantial amount of light incident at an interface
5 between the material of the tube and surrounding material undergoes total internal reflection. The tube material may be either coated in a coating with a suitable refractive index or designed to operate in air, in which case the refractive index of the light guide material should be such that total internal reflection occurs at the material air interface.

10

Using a tube like this as a light guide results in multiple images of the light source being generated which can be projected to the scene to form the array of spots. The light guide is easy to manufacture and assemble and couples the majority of the light from the source to the scene. Thus low power sources such as light emitting diodes
15 can be used. As the exit aperture can be small the apparatus also has a large depth of field which makes it useful for ranging applications which require spots projected that are separated over a wide range of distances.

The projection optics may comprise a projection lens. The projection lens may be
20 located adjacent the output face of the light guide. In some embodiments where the light guide is solid the lens may be integral to the light guide, i.e. the tube may be shaped at the output face to form a lens.

Preferably the projection optics are adapted so as to focus the projected array at
25 relatively large distances. This provides a sharp image at large distances and a blurred image at closer distances. As discussed above the amount of blurring can give some coarse range information which can be used to resolve ambiguities. The discrimination is improved if the light source has a non circular shape, such a square.

30 In order to further remove ambiguity the light source may have a shape which is not symmetric about the axes of reflection of the light guide. If the light source is not symmetrical about the axis of reflection the light source will be different to its mirror image. Adjacent spots in the projected array are mirror images and so shaping the light source in this manner would allow discrimination between adjacent spots.

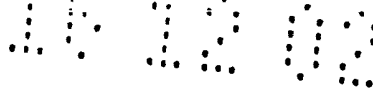

The apparatus may comprise more than one light source, each light source arranged to illuminate part of the input face of the light guide. Using more than one light source can improve the spot resolution in the scene. Preferably the more than one light sources are arranged in a regular pattern. The light sources may be arranged such that different arrangements of sources can be used to provide differing spot densities. For instance a single source could be located in the centre of the input face of the light guide to provide a certain spot density. A separate two by two array of sources could also be arranged on the input face and could be used instead of the central source to provide an increased spot density.

Where more than one light sources are used at least one light source could be arranged to emit light at a different wavelength to another light source. Using sources with different wavelengths means that the array of spots projected into a scene will have differing wavelengths, in effect the sources and hence corresponding spots will be different colours – although the skilled person will appreciate that the term colour is not meant to imply operation in the visible spectrum. Having varying colours will help remove ambiguity over which spot is which in the projected array.

Alternatively at least one light source could be shaped differently from another light source, preferably at least one light source having a shape that is not symmetric about a reflection axis of the light guide. Shaping the light sources again helps discriminate between spots in the array and having the shapes non symmetrical means that mirror images will be different, further improving discrimination as described above.

At least one light source could be located within the light guide, at a different depth to another light source. The angular separation of the projected array from a kaleidoscope is determined by the ratio of its length to its width as will be described later. Locating at least one light source within the kaleidoscope effectively shortens the effective length of light guide for that light source. Therefore the resulting pattern projected towards the scene will comprise more than one array of spots having different periods. The degree of overlap of the spot will therefore change with distance from the centre of the array which can be used to identify each spot uniquely.

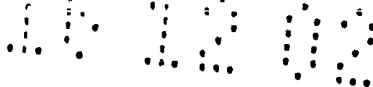

The invention will now be described by way of example only with reference to the following drawings of which;

5 Figure 1 shows a prior art single spot ranging system,

Figure 2 shows an embodiment of the ranging system of the present invention,

10 Figure 3 shows a suitable spot projector for use in the ranging system of the present invention,

Figure 4 illustrates the principle of operation of the spot projector shown in Figure 3,

15 Figure 5 shows an alternative spot projector and the output thereof,

Figure 6 shows the input face of a spot projector having variable spot density projection,

20 Figure 7 shows the input face of an alternative type of suitable spot projector and the pattern produced therefrom,

Figure 8 shows another suitable spot projector,

25 Figure 9 shows an embodiment of the invention using two cameras, and

Figure 10 shows the input face of a spot projector for producing spots formed from the intersection of continuous lines.

30 Figure 1 shows a prior art ranging system using a single spot. A scanning source 2 produces a single beam of light 4 which is projected towards a scene. Detector 6 looks towards the scene and detects where in the scene the spot is located. Figure 1a shows the apparatus with a target 8 at a first range and also illustrates the scene 10 as

it appears to the detector. The spot 12 can be seen at a particular location governed by the angle θ_1 which is itself determined by the range to the object.

Figure 1b shows the same apparatus when target 8 is removed and a new target 14 is introduced further away. The new angle θ_2 to the spot is lower than θ_1 and so the detector 6 sees the spot 12 in a different location. The apparent movement of the spot in the scene is shown by arrow 16.

It can be seen then that when a beam of light is projected at a known angle from the scanning source 2 the location of the spot 12 in the detected scene 10 can give range information. As the range of the target is varied the spot appears to move across the scene. The spot therefore has a locus of apparent movement across the scene with varying range which is determined by the arrangement of the source 2 and detector 6.

The prior art is limited however in that the spot must be scanned across the whole of the scene to generate range information from across the scene. Scanning requires complicated mechanical systems and means that ranging to the entire scene takes a relatively long time.

The present invention uses a two dimensional array of spots to gain range information from the whole scene simultaneously. Using a two dimensional array of spots can lead to ambiguity problems as illustrated with reference to Figure 2a. Here like components to figure 1 have like numerals. The arrangement is the same except for the fact that scanning source 2 is replaced with a two dimensional spot projector 22 and processor 7 is indicated. The spot projector 22 projects a plurality of angularly separated beams 24a, 24 b (only two are shown for clarity). Where the scene is a flat target the image 10 the detector sees is a square array of spots 12. As can be seen from figure 2a though a spot appearing at a particular location in the scene, say that received at angle θ_1 , could correspond to a first projected spot, that from beam 24b, being reflected from a target 8 at a first range or a second, different projected spot, that from beam 24a, being reflected from a target 14 at a more distant range. Again each spot in the array can be thought of as having a locus in the scene of varying range. It can be seen that the locus for one spot, arrow 26, can overlap with the position of other spots, giving rise to range ambiguity.

One embodiment of the present invention avoids this problem by arranging the spot projector relative to the detector such that the array of spots is projected such that the loci of possible positions in the detected scene at varying range of adjacent spots do not overlap. Figure 2b therefore shows the apparatus of the present invention from a side elevation. It can be seen that the detector 6 and spot projector 22 are separated in the y-direction as well as the x-direction. Therefore the y-position of a spot in the scene also varies with range, which has an effect on the locus of apparent spot motion. The arrangement is chosen such that the loci of adjacent spots do not overlap. The actual locus of spot motion is indicated by arrow 28.

Another way of thinking of this would be to redefine the x-axis as the axis along which the detector and spot projector are separated, or at least the effective input/exit pupils thereof if mirrors or other diverting optical elements were used. The z-axis is the range to the scene to be measured and the y-axis is orthogonal. The detector therefore forms a two dimensional x-y image of the scene. In this coordinate system there is no separation of the detector and projector in the y-direction and so a spot projected by the projector at a certain angle in the z-y plane will always be perceived to be at that angle by the detector, irrespective of range, i.e. the spot will only appear to move in the detected scene in a direction parallel to the x-direction. If the array is therefore arranged with regard to the x-axis such that adjacent spots have different separations in the y-direction there will be no ambiguity between adjacent spots. Where the array is a square array of spots this would in effect mean tilting the array such that an axis of the array does not lie along the x-axis as defined, i.e. the axis by which the detector and spot projector are separated.

For wholly unambiguous determination of which spot is which the spot size, inter-spot gap and arrangement of the detector would be such that the locus of each spot did not overlap with the locus of any other spot. However for practical reasons of discrimination a large number of spots is preferable with a relatively large spot size. In practice then the loci of different spots will overlap. As can be seen in figure 2b the locus of projected spot 30 does overlap with projected spot 32 and therefore a spot detected in the scene along the line of arrow 28 could correspond to projected spot 30 at one range or projected spot 32 at a different range. However the difference in the

two ranges will be significant. In some applications the ranging system may only be used over a narrow band of possible ranges and hence within the operating window there may be no ambiguity. However for some applications it will be necessary to resolve the ambiguity. As the difference in possible ranges is relatively large however
 5 a coarse ranging technique could be used to resolve the ambiguity with the ranging system then providing accurate range information.

In one embodiment spot projector 22 projects an array of square spots which is focussed at relatively long range. If the processor sees square spots in the detected
 10 scene this means that the spots are substantially focussed and so the detected spot is at relatively long range. However if the spot is at close range it will be substantially unfocussed and will appear circular. A focal length of 800mm may be typical. Thus the appearance of the spot may be used to provide coarse range information to remove ambiguity over which spot has been detected with the location of the spot then being
 15 used to provide fine range information.

The detector 6 is a standard two dimensional CCD array, for instance a standard CCD camera although a CMOS camera could be used instead. The detector 6 should have sufficient resolution to be able to identify the spots and the position thereof in the
 20 scene. The detector 6 may be adapted to capture a visible image as well as detect the spots in the scene. Where the spot projector projects infrared spots onto the scene the detector used is a CCD camera with four elements to each pixel group. One element detects red light, another blue light and a third green light. The four element system is adapted to detect infrared light at the appropriate wavelength. Thus the readout from
 25 the RGB elements can be used to form a visible image and the output of the infrared elements provided to the processor to determine range. Where spots are projected at different wavelengths however as will be described later the detector must be adapted to distinguish between different infrared wavelengths, in which case a different camera may be preferred.

30

In order to aid spot detection and avoid problems with ambient light the spot projector is adapted to project a modulated signal. The processor is adapted to filter the detected signal at the modulation frequency to improve the signal to noise ratio. The simplest realisation of this principle is to use a pulsed illumination, known as

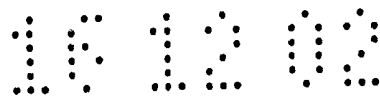

strobing. The camera captures one frame when the pulse is high. A reference pulse is also taken without the spots projected. The difference of these intensity patterns is then corrected in terms of background lighting offsets. In addition a third reflectivity reference frame could be collected when synchronised to a uniformly illuminated
5 LED flashlamp which would allow a normalisation of the intensity pattern.

A suitable spot projector 22 is shown in figure 3. A light source 34 is located adjacent an input face of a kaleidoscope 36. At the other end is located a simple projection lens 38. The projection lens is shown spaced from the kaleidoscope for the purposes
10 of clarity but would generally be located adjacent the output face of the kaleidoscope.

The light source 34 is an infrared emitting light emitting diode (LED). As discussed above infrared is useful for ranging applications as the array of projected spots need not interfere with a visual image being acquired and infrared LEDs and detectors are
15 reasonably inexpensive. However the skilled person would appreciate that other wavelengths and other light sources could be used for other applications without departing from the spirit of the invention.

The kaleidoscope is a hollow tube with internally reflective walls. The kaleidoscope
20 could be made from any material with suitable rigidity and the internal walls coated with suitable dielectric coatings. However the skilled person would appreciate that the kaleidoscope could alternatively comprise a solid bar of material. Any material which is transparent at the wavelength of operation of the LED would suffice, such as clear optical glass. The material would need to be arranged such that at the interface
25 between the kaleidoscope and the surrounding air the light is totally internally reflected within the kaleidoscope. Where high projection angles are required this could require the kaleidoscope material to be cladded in a reflective material. An ideal kaleidoscope would have perfectly rectilinear walls with 100% reflectivity. It should be noted that a hollow kaleidoscope may not have an input or output face as
30 such but the entrance and exit to the hollow kaleidoscope should be regarded as the face for the purposes of this specification.

The effect of the kaleidoscope tube is such that multiple images of the LED can be seen at the output end of the kaleidoscope. The principle is illustrated with reference

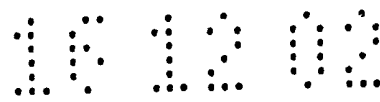

to figure 4. Light from the LED 34 may be transmitted directly along the kaleidoscope undergoing no reflection at all – path 40. Some light however will be reflected once and will follow path 42. Viewed from the end of the kaleidoscope this will result in a virtual source 44 being seen. Light undergoing two reflections would travel along path 46 resulting in another virtual source 48 being observed.

The dimensions of the device are tailored for the intended application. Imagine that the LED 34 emits light into a cone with a full angle of 90° . The number of spots viewed on either side of the centre, unreflected, spot will be equal to the kaleidoscope length divided by its width. The ratio of spot separation to spot size is determined by the ratio of kaleidoscope width to LED size. Thus a $200\mu\text{m}$ wide LED and a kaleidoscope 30mm long by 1mm square will produce a square grid of 61 spots on a side separated by five times their width (when focussed). For typical applications however the spot projector is designed to produce an array of 40×30 spots to be projected to the array.

Projection lens 38 is a simple singlet lens arranged at the end of kaleidoscope and is chosen so as to project the array of images of the LED 34 onto the scene. The projection geometry again can be chosen according to the application and the depth of field required but a simple geometry is to place the array of spots at or close to the focal plane of the lens.

As mentioned LED 34 may be square in shape and projection lens 38 could be adapted to focus the array of spots at a distance towards the upper expected range such that the degree of focus of any particular spot can yield coarse range information.

A spot projector as described has several advantages. The kaleidoscope is easy and inexpensive to manufacture. LEDs are cheap components and as the kaleidoscope efficiently couples light from the LED to the scene a relatively low power source can be used. The spot projector as described is therefore an inexpensive and reasonably robust component and also gives a large depth of focus which is very useful for

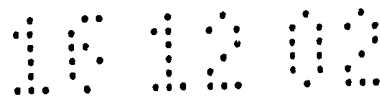

ranging applications. A kaleidoscope based spot projector is thus preferred for the present invention.

5 The skilled person would appreciate however that other spot projectors could be used to generate the two dimensional array. For instance a laser could be used with a diffractive element to generate a diffraction pattern which is an array of spots. Alternatively a source could be used with projection optics and a mask having an array of apertures therein. Any source that is capable of projecting a discrete array of spots of light to the scene would suffice, however the depth of field generated by
10 other means, LED arrays, microlens arrays etc., has generally been found to be very limiting in performance.

An apparatus as shown in Figure 2 was constructed using a spot projector as shown in figure 3. The spot projector illuminated the scene with an array of 40 by 30 spots.
15 The operating window was 60° full angle. The spots were focussed at a distance of 1m and the ranging device worked well in the range 0.5m to 2m. The detector was a 308 kpixel (VGA) CCD camera. The range to different objects in the scene were measured to an accuracy of 0.5mm at mid range.

20 Before the apparatus as described above can be used to produce range data, it must first be calibrated. In principle, the calibration can be generated from the geometry of the system. In practice, it is more convenient to perform a manual calibration. This allows for imperfections in construction and is likely to produce better results.

25 Calibration data are obtained by placing a test object at a series of known distances and recording the spot positions as a function of range. The most convenient test object is a flat, matt plane of uniform colour, preferably white, which fills the field of view of the camera at all ranges. A flat white wall would be ideal (obviously the camera would move in this case), however any deviations from flatness would affect
30 the accuracy of the calibration.

Initially, the camera is placed at a large distance from the wall, about 1.5m would do the system described above, and the location of each spot in the image is recorded (spot-finding algorithms are described below). As the camera moves closer to the

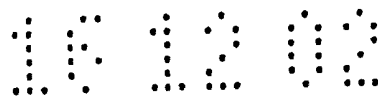

wall all the spots in the image move in roughly the same direction so it is a fairly simple matter to track them. The spots move along a straight line in the image as is apparent from the equations above. A linear regression provides the formula for the track of each line in the form:

$$b = ma + c$$

where the coordinates of the spot are (a,b).

The design of the kaleidoscope projector ensures that all beams appear to originate from a common origin. Therefore, all the tracks of the spots intersect at a common point, which is the projection of the beam origin, through the principal point of the camera lens, onto the camera focal plane. This track origin can be calculated by finding the intersection of the measured spot tracks. In practice, the spot tracks are unlikely to all intersect at the same point due to uncertainties in the measurements. It is sufficient to select one of the tracks and find the intersection point of this track with all the others. This will produce a series of values for the coordinates of the origin. The position of the origin can then be determined by selecting the median value of each coordinate.

The next stage in the calibration procedure is to determine an identifier, i , for each track, which can be used for determining the identity of spots when the camera is used to produce range data. Two possible identifiers have been identified. If the spot tracks are all parallel then the gradient, m , of all the lines is the same. The intercept, c , is then the identifier. If the tracks are not parallel, then the angle between the line joining the midpoint of each track to the track origin and the x -axis is the identifier.

The final stage of the calibration is to determine the relationship between the spot position along a track and the range. This can be found according to the formula:

$$z - z_0 = k / (r - r_0)$$

where z is the range along the z -axis and r is the position of the spot along the track. The position r can be measured along any convenient axis but the most convenient measure is to express r as a distance from the track origin. The constants k , z_0 and r_0 for each track can be found by fitting the formula above to the measured data. In a well-aligned system, the values for k and z_0 should be similar for all tracks.

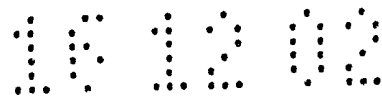

The outcome of the calibration procedure consists of the track origin and a list of six numbers for each track: i, m, c, k, r_0, z_0 .

After calibration the system is ready to determine range. The range finding algorithm consists of four basic stages. These are:

- 1 Normalise the image
- 2 Locate the spots in the image.
- 3 Identify the spots
- 4 Calculate range data

10

Normalisation

Since the camera has been filtered to select only light from the kaleidoscope, there should be a very low level of background light in the image. Therefore, any regions that are bright in comparison to the local background can be reasonably expected to be spots. However, the relative brightnesses of different spots will vary according to the range, position and reflectivity of the target. It is therefore convenient as a first step to normalise the image to remove unwanted background and highlight the spots.

The normalisation procedure consists of calculating the 'average' intensity in the neighbourhood of each pixel, dividing the signal at the pixel by its local average and then subtracting unity. If the result of this calculation is less than zero, the result is set to zero.

Spot location

Spot location consists of two parts. The first is finding the spot. The second is determining its centre. The spot-finding routine maintains two copies of the normalised image. One copy (image A) is changed as more spots are found. The other (image B) is fixed and used for locating the centre of each spot.

As it is assumed that all bright features in the normalised images are spots, the spots can be found simply by locating all the bright regions in the image. The first spot is assumed to be near the brightest point in image A. The coordinates of this point are used to determine the centre of the spot and an estimate of the size of the spot (see below). The intensity in the region around the spot centre (based on the estimated spot size) is then set to zero in image A. The brightest remaining point in image A is then used to find the next spot and so on.

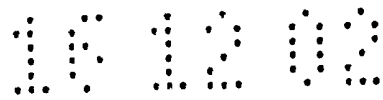

The spot-finding algorithm described above will find spots indefinitely unless extra conditions are imposed. Three conditions have been identified, which are used to terminate the routine. The routine terminates when any of the conditions is met. The first condition is that the number of spots found should not exceed a fixed value. The second condition is that the routine should not repeatedly find the same spot. This occurs occasionally under some lighting conditions. The third condition is that the intensity of the brightest point remaining in image A falls below a predetermined threshold value. This condition prevents the routine from finding false spots in the picture noise. Usually the threshold intensity is set to a fraction (typically 20%) of the intensity of the brightest spot in image B.

The centre of each spot is found from image B using the location determined by the spot-finding routine as a starting point. A sub-image is taken from image B, centred on that point. The size of the sub-image is chosen to be slightly larger than the size of a spot. The sub-image is reduced to a one-dimensional array by adding the intensity values in each column. The array is then correlated with a gaussian function and the peak of the correlation (interpolated to a fraction of a pixel) is defined as the centre of the spot in the horizontal direction. The centre of the spot in the orthogonal direction is found in a similar manner by summing rows in the sub-image instead of columns.

If the centre of the spot determined by the procedure above is more than two pixels away from the starting point, the procedure should be repeated iteratively, using the calculated centre as the new starting point. The calculation continues until the calculated position remains unchanged or a maximum number of iterations is reached. This allows for the possibility that the brightest point is not at the centre of the spot. A maximum number of iterations (typically 5) should be used to prevent the routine from hunting in a small region. The iterative approach also allows spots to be tracked as the range to an object varies, provided that the spot does not move too far between successive frames. This feature is useful during calibration.

Having found the centre of the spot, the number of pixels in the sub-image with an intensity greater than a threshold value (typically 10% of the brightest pixel in the sub-image) is counted. The spot size is defined as the square root of this number.

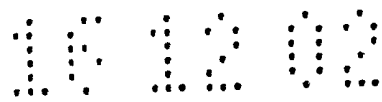

The outcome of the spot locating procedure is a list of (a,b) coordinates, each representing a different spot.

Spot Identification

- 5 The range to each spot can only be calculated if the identity of the spot can be determined. The simplest approach to spot identification is to determine the distance from the spot to each spot track in turn and eliminate those tracks that lie outside a pre-determined distance (typically less than one pixel for a well-calibrated system). This approach may be time-consuming when there are many spots and many tracks.
- 10 A more efficient approach is to calculate the identifier for the spot and compare it with the identifiers for the various tracks. Since the identifiers for the tracks can be pre-sorted, the search can be made much quicker. The identifier is calculated in the same way as in the calibration routine.
- 15 Once candidate tracks have been identified, it is necessary to consider the position of the spot along the track. If the range of possible distances is limited, (e.g. nothing can be closer than, say, 150mm or further than 2500mm) then many of the candidate tracks will be eliminated since the calculated range will be outside possible boundaries. In a well-adjusted system, at most two tracks should remain. One track
- 20 will correspond to a short range and the other to a much longer range.

A final test is to examine the shape of the spot in question. As described the projector 22 produces spots that are focussed at long ranges and blurred at short ranges. Provided that the LEDs in the projector have a recognisable shape (such as square)

25 then the spots will be round at short distances and shaped at long distances. This should remove any remaining range ambiguities.

Any spots that remain unidentified are probably not spots at all but unwanted points of light in the scene.

30

Range calculation

Once a spot has been identified, its range can be calculated. In order to produce a valid 3-dimensional representation of the scene it is also necessary to calculate x and y -coordinates. These can simply be derived from the camera properties. For

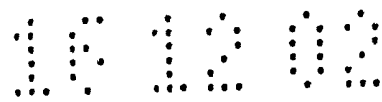

example, for a camera lens of focal length f with pixel spacing p , the x - and y -coordinates are simply given by:

$$x = z a p / f, \quad y = z b p / f$$

where a and b are measured in pixel coordinates.

5

The embodiment described above was adjusted so as to have minimal ambiguity between possible spots and use focus to resolve the ambiguity. Other means of resolving ambiguity may be employed however. In one embodiment of the invention the apparatus includes a spot projector generally as described with reference to figure 3 but in which the light source is shaped so as to allow discrimination between adjacent spots. Where the light source is symmetric about the appropriate axes of reflection the spots produced by the system are effectively identical. However where a non symmetrically shaped source is used adjacent spots will be distinguishable mirror images of each other. The principle is illustrated in figure 5.

15

The structured light generator 22 comprises a solid tube of clear optical glass 56 having a square cross section. A shaped LED 54 is located at one face. The other end of tube 56 is shaped into a projection lens 58. Kaleidoscope 56 and lens 58 are therefore integral which increases optical efficiency and eases manufacturing as a single moulding step may be used. Alternatively a separate lens could be optically cemented to the end of a solid kaleidoscope with a plane output face.

20

For the purposes of illustration LED 54 is shown as an arrow pointing to one corner of the kaleidoscope, top right in this illustration. The image formed on a screen 60 is shown. A central image 62 of the LED is formed corresponding to an unreflected spot and again has the arrow pointing to the top right. Note that in actual fact a simple projection lens will project an inverted image and so the images formed would actually be inverted. However the images are shown not inverted for the purposes of explanation. The images 64 above and below the central spot have been once reflected and therefore are a mirror image about the x -axis, i.e. the arrow points to the bottom right. The next images 66 above or below however have been twice reflected about the x -axis and so are identical to the centre image. Similarly the images 68 to the left and right of the centre image have been once reflected with regard to the y -axis and so the arrow appears to point to the top left. The images 70 diagonally

25

30



adjacent the centre spot have been reflected once about the x-axis and once about the y-axis and so the arrow appears to point to the bottom left. Thus the orientation of the arrow in the detected image gives an indication of which spot is being detected. This technique allows discrimination between adjacent spots but not subsequent spots.

5

In another embodiment more than one light source is used. The light sources could be used to give variable resolution in terms of spot density in the scene, or could be used to aid discrimination between spots, or both.

10 For example if more than one LED were used and each LED was a different colour the pattern projected towards the scene would have different coloured spots therein. The skilled person would appreciate that the term colour as used herein does not necessarily mean different wavelengths in the visible spectrum but merely that the LEDs have distinguishable wavelengths.

15

The arrangement of LEDs on the input face of the kaleidoscope effects the array of spots projected and a regular arrangement is preferred. To provide a regular array the LEDs should be regularly spaced from each other and the distance from the LED to the edge of the kaleidoscope should be half the separation between LEDs.

20

Figure 6 shows an arrangement of LEDs that can be used to give differing spot densities. Thirteen LEDs are arranged on the input face 72 of a square section kaleidoscope. Nine of the LEDs, 76 & 74a - h, are arranged in a regular 3x3 square grid pattern with the middle LED 76 centred in the middle of the input face. The remaining four LEDs, 78a - d are arranged as they would be to give a regular 2x2 grid. The structured light generator can then be operated in three different modes. Either the central LED 76 could be operated on its own, this would project a regular array of spots as described above, or multiple LEDs could be operated. For instance, the four LEDs 78a-d arranged in the 2x2 arrangement could be illuminated to give an array with four times as many spots produced than with the centre LED 76 alone.

30

The different LED arrangements could be used at different ranges. When used to illuminate scenes where the targets are at close range the single LED may generate a sufficient number of spots for discrimination. At intermediate or longer ranges

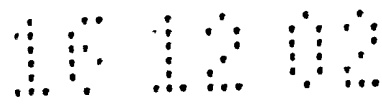

however the spot density may drop below an acceptable level, in which case either the 2x2 or 3x3 array could be used to increase the spot density. As mentioned the LEDs could be different colours to improve discrimination between different spots.

5 Where multiple sources are used appropriate choice of shape or colour of the sources can give further discrimination. This is illustrated with respect to figure 7. Here a 2x2 array of differently shaped sources, 82, 84, 86, 88 is illustrated along with a portion of the pattern produced. One can think of the resultant pattern formed as a tiled array of images of the input face 80 of the kaleidoscope with each adjacent tile
10 being a mirror image of its neighbour about the appropriate axis. Looking just in the x-axis then the array will be built up by spots corresponding to LEDs 82 and 84 and followed by spots corresponding to their mirror images. The resultant pattern means that each spot is different from its next three nearest neighbours in each direction and ambiguity over which spot is being observed by a detector would be reduced.

15

Where multiple sources are used the sources may be arranged to be switched on and off independently to further aid in discrimination. For instance several LEDs could be used, arranged as described above, with each LED being activated in turn.

Alternatively the array could generally operate with all LEDs illuminated but in
20 response to a control signal from the processor which suggests some ambiguity could be used to activate or deactivate some LEDs accordingly.

All of the above embodiments using shaped LEDs or LEDs of different colours can be combined with appropriate arrangement of the detector and spot projector such that
25 where the locus of a spot overlaps with another spot the adjacent spots on that locus have different characteristics. For example, referring back to Figure 2b it can be seen that the arrangement is such that the locus of spot 30 overlaps with spot 32, i.e. a spot detected at the position of spot 32 shown could correspond to projected spot 32 reflected from a target at a first range or projected spot 30 reflected from a target at a
30 different range. However imagine that the spot projector of figure 5 were used. It can be seen that if projected spot 30 were an arrow pointing to the upper right then projected spot 32, but virtue of its position in the array, would be an arrow pointing to the upper left. Thus there would be no ambiguity over which spot was which as the direction of the arrow would indicate which spot was being observed.

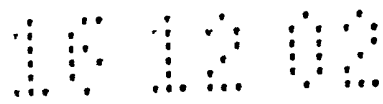

In a further embodiment lights sources are arranged at different depths within the kaleidoscope. The angular separation of adjacent beams from the kaleidoscope depends upon the ratio between the length and width of the kaleidoscope as discussed above. Figure 8 shows a square section kaleidoscope 96 and projection lens 98. The kaleidoscope tube 96 is formed from two pieces of material 96a and 96b. A first LED 98 is located at the input face of the kaleidoscope as discussed above. A second LED 100 is located at a different depth within the kaleidoscope, between the two sections 96a and 96b of the kaleidoscope. The skilled person would be well aware of how to join the two sections 96a and 96b of kaleidoscope to ensure maximum efficiency and located the second LED 100 between the two sections.

The resulting pattern contains two grids with different periods, the grid corresponding to the second LED 100 partially obscuring the grid corresponding to the first LED 98. As can be seen the degree of separation between the two spots varies with distance from the centre spot. The degree of separation or offset of the two grids could then be used to identify the spots uniquely. The LEDs 98, 100 could be different colours as described above to improve discrimination.

It should be noted that the term spot should be taken as meaning a point of light which is distinguishable. It is not intended to limit to an entirely separate area of light. Figure 10 for instance illustrates an alternative spot projector that could be used. Here a cross shaped LED 120 is used on the input face of the kaleidoscope. The LED 120 extends to the side walls of the kaleidoscope and so the projected pattern will be a grid of continuous lines 122 as illustrated. The intersection of the lines provides an identifiable area or spot which can be located and the range determined in the same manner as described above.

Once the range to the intersection has been determined the range to any point on the line passing through that intersection can be determined using the information gained from the intersection point. Thus the resolution of the system is greatly magnified. Using the same 40x30 projection system described above but with the LED arrangement shown in figure 10 there are 1200 intersection points which can be identified to a system with far more range points. The apparatus could be used



therefore with the processor arranged to identify each intersection point and determine the range thereto and then work out the range to each point on the connecting lines. Alternatively the cross LED could comprise a separate centre portion 124 which can be illuminated separately. Illumination of the central LED portion 124 would cause an array of spots to be projected as described earlier. Once the range to each spot had been determined the rest of cross LED 120 could be activated and the range to various points on the connecting lines determined. Having the central portion only illuminated first may more easily allow ambiguities to be resolved based on shaped of the projected spots.

10

Another embodiment of the invention is shown in figure 9. Here two CCD cameras 6, 106 are used to look at the scene. Spot projector 22 may be any of the spot projectors described above and projects a regular array of spots. CCD camera 6 is the same as described above with respect to figure 2. A second camera 106 is also provided which is identical to camera 6. A beamsplitter 104 is arranged so as to pass some light from the scene to camera 6 and reflect some light to camera 106. The arrangement of camera 106 relative to beamsplitter 104 is such that there is a small difference 108 in the effective positions of the two cameras. Each camera therefore sees a slightly different scene. If the camera positions were sufficiently far removed the beamsplitter 104 could be omitted and both cameras could be oriented to look directly towards the scene but the size of components and desired spacing may not allow such an arrangement.

15

20

The output from camera 6 could then be used to calculate range to the scene as described above. Camera 106 could also be used to calculate range to the scene. The output of each camera could be ambiguous in the manner described above in that a detected spot may correspond to any of one of a number of possible projected spots at different ranges. However as the two cameras are at different spacings the set of possible ranges calculated for each detected spot will vary. Thus for any detected spot only one possible range, the actual range, will be common to the sets calculated for each camera.

30

When camera 6 is located with a very small baseline, i.e. separation of line of sight, from the spot projector the corresponding loci of possible positions of spots in the

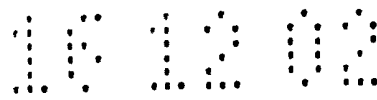

scene at different ranges are small. Referring back to figure 2a it can be seen that if the separation from the detector 6 to the spot projector 22 is small the apparent movement in the scene of a spot at different ranges will not be great. Thus the locus will be small and there may be no overlap between loci of different spots in the operating window, i.e. no ambiguity. However a limited locus of possible positions means that the system is not as accurate as one with a greater degree of movement. For a system with reasonable accuracy and range a baseline of approximately 60mm would be typical. Referring to figure 9 then if camera 6 is located close to the line of sight of the spot projector the output from camera 6 would be a non ambiguous but low accuracy measurement. Camera 106 however may be located at an appropriate baseline from the spot projector 22 to give accurate results. The low accuracy readings from the output from camera 6 could be used to resolve any ambiguity in the readings from camera 106.

Alternatively the outputs from the two camera themselves could be used to give coarse ranging. If the arrangement is such that the baseline between the cameras is small, say about 2mm, the difference in detected position of a spot in the two cameras can be used to give a coarse estimate of range. The baseline between either camera and the projector may be large however. The advantage of this configuration is that the two cameras are looking at images with very small differences between them. The camera to projector arrangement needs to determine spot location by correlation of the recovered spot with a stored gaussian intensity distribution to optimise the measurement of the position of the spot. This is reasonable but never a perfect match as the spot sizes change with range and reflectivity may vary across the spot. Surface slope of the target may also effect the apparent shape. The camera to camera system looks at the same, possibly distorted spot, from two viewpoints which means that the correlation is always nearly a perfect match.

A ranging system as described could be used in any number of applications. As the spot projection system is easy and inexpensive to manufacture and need not interfere with a visible image being acquired virtually any camera system could be integrated with a ranging system according to the present invention. Ranging systems according to the present invention could be used to improve imaging target identification systems as the range to the scene would reveal addition information about object

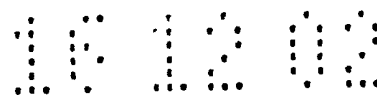

edges. This could be used in security applications for intruder alarms and the like. Alternatively range information could improve object identification, for instance facial recognition.

- 5 The system has obvious potential for use in proximity sensors, for instance such as those employed in vehicles. Also in vehicles range information could be collected about the occupant position which could be used in safer deployment of emergency safety equipment such as air bags.

- 10 Range information could be used to acquire three dimensional information useful for modelling of objects. Biometric information could be acquired to ensure correct sizing of clothing. A booth provided could be provided with a plurality of cameras and spot projectors to image a whole person, possibly from more than one viewing direction. A person could then stand momentarily within such a booth and be imaged
15 and ranged from a multiplicity of directions. This information could be captured and processed to give create a model of the person which could be used for various design or garment fitting applications.

Another useful embodiment is in document scanning. Scanning of documents, such
20 as books, generally requires the page of the book to be pressed as flat as possible against a transparent surface through which the book or document is imaged. However it is not always practical to image a document in such a manner. Were the document imaged as it just lay open however the curvature of the book would mean that a distorted image would result. Were however the imager combined with a range
25 finding apparatus as described the range to the surface of the book could reveal the curvature thereof. Image processing algorithms could then be used to correct the imaged page for the curvature thereof and present a 'flat' image.

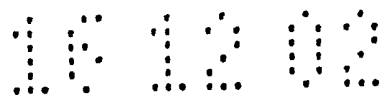

CLAIMS

1. A ranging apparatus comprising an illumination means for illuminating a scene with a projected two dimensional array of light spots, a detector for detecting the location of spots in the scene and a processor adapted to determine, from the detected location of a spot in the scene, the range to that spot.
2. A ranging apparatus as claimed in claim 1 wherein the illumination means and detector are arranged such that each spot in the projected array appears to move in the detected scene, from one range to another, in a direction parallel to a first axis and each adjacent spot in the projected array is a different perpendicular distance from the first axis.
3. A ranging apparatus as claimed in claim 1 or claim 2 wherein the illumination means is adapted to project an array of spots which is focussed at a first distance and unfocussed at a second distance, the first and second distances being within the operating range of the apparatus.
4. A ranging apparatus as claimed in claim 3 wherein the illumination means is adapted to project an array of spots which are non-circular in shape when focussed.
5. A ranging apparatus as claimed in any preceding claim wherein the illumination means is adapted to periodically alter the two dimensional array of projected spots.
6. A ranging apparatus as claimed in claim 5 wherein the illumination means is adapted to illuminate the scene cyclically with different arrays of spots.
7. A ranging apparatus as claimed in claim 5 wherein the processor is adapted to determine any areas of ambiguity in the detected array and deactivate one or more of the projected spots so as to resolve the ambiguity.

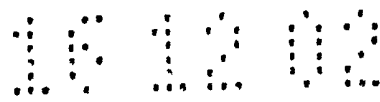

8. A ranging apparatus as claimed in any preceding claim wherein the illumination means is adapted to so as to produce an array of spots wherein each projected spot has a different characteristic to its adjacent spots.
9. A ranging apparatus as claimed in claim 8 wherein the characteristic is colour.
10. A ranging apparatus as claimed in claim 8 or claim 9 wherein the characteristic is shape.
11. A ranging apparatus as claimed in any of claims 1 to 7 wherein the spots comprise intersections between continuous lines.
12. A ranging apparatus as claimed in claim 11 wherein the illumination means projects two sets of regularly spaced lines, the two sets of lines being substantially orthogonal.
13. A ranging apparatus as claimed in claim 12 wherein the processor is adapted to determine the range to the intersections between the continuous lines and then, using the determined range information determine the range to other points on the continuous lines.
14. A ranging apparatus as claimed in any preceding claim wherein the detector comprises a two dimensional CCD or CMOS array.
15. A ranging apparatus as claimed in any preceding claim wherein the illumination means is adapted such that the two dimensional array of spots are infrared spots.
16. A ranging apparatus as claimed in claim 15 wherein the detector is adapted to capture a visible image of the scene as well as the location of the infrared spots in the scene.
17. A ranging apparatus as claimed in any preceding claim wherein the baseline between the illumination means and the detector is between 50 and 100mm.

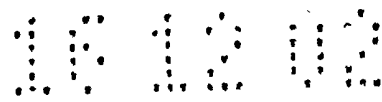

18. A ranging apparatus as claimed in any preceding claim wherein the detector is adapted to image the scene from more than one direction.
19. A ranging apparatus as claimed in claim 18 wherein the apparatus includes scanning optics in the optical path to the detector adapted to periodically redirect the viewing direction of the detector.
20. A ranging apparatus as claimed in claim 18 wherein the detector comprises two detector arrays each detector array arranged so as to image the scene from a different direction.
21. A ranging apparatus as claimed in any of claims 18 to 20 wherein the processor applies image processing algorithms to the scenes from each viewpoint to determine range information therefrom.
22. A ranging apparatus as claimed in any of claims 18 to 21 wherein the detector means is adapted to have a different baseline to the illumination means in each viewpoint.
23. A ranging apparatus as claimed in claim 22 wherein the processor is adapted to determine the possible range to the scene from each viewpoint and compare the possible ranges to resolve any ambiguity.
24. A ranging apparatus as claimed in any preceding claim wherein the apparatus further comprises a plurality of illumination means arranged to illuminate the scene from different directions, the system being adapted to periodically change the illumination means used to illuminate the scene.
25. A ranging apparatus as claimed in claim 24 wherein the processor is adapted to determine the possible range to the scene when illuminated with each illumination means and compare the possible ranges to resolve any ambiguity.

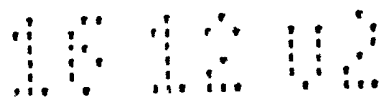

26. A ranging apparatus as claimed in claim 24 or claim 25 wherein each illumination means is arranged to have a different baseline to each detector.
27. A ranging apparatus as claimed in any preceding claim wherein the illumination means comprises a light source arranged to illuminate part of the input face of a light guide, the light guide comprising a tube having substantially reflective sides and being arranged together with projection optics so as to project an array of distinct images of the light source towards the scene.
28. A ranging apparatus as claimed in claim 27 wherein the light guide comprises a tube having a square cross section.
29. A ranging apparatus as claimed in claim 27 or claim 28 wherein the light guide comprises a tube having reflective internal surfaces.
30. A ranging apparatus as claimed in claim 27 or claim 28 wherein the light guide comprises a tube of solid material adapted such that a substantial amount of light incident at an interface between the material of the tube and surrounding material undergoes total internal reflection.
31. A ranging apparatus as claimed in any of claims 27 to 30 wherein the projection optics comprises a projection lens.
32. A ranging apparatus as claimed in any of claims 27 to 31 wherein the light source has a non-circular shape.
33. A ranging apparatus as claimed in claim 32 wherein the light source has a shape which is non symmetric about the axes of reflection of the light guide.
34. A ranging apparatus as claimed in any of claims 27 to 33 wherein the illumination means comprises more than one light source, each light source arranged to illuminate part of the input face of the light guide.

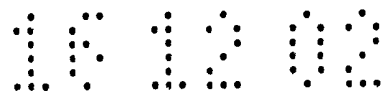

35. A ranging apparatus as claimed in claim 34 wherein the light sources are arranged in a regular pattern.
36. A ranging apparatus as claimed in any of claims 34 or 35 wherein the light sources are arranged to provide differing spot densities.
37. A ranging apparatus as claimed in any of claims 34 to 36 wherein at least one light source emits light at a different wavelength to another light source.
38. A ranging apparatus as claimed in any of claims 34 to 37 wherein at least one light source is shaped differently to another light source.
39. A ranging apparatus as claimed in any of claims 34 to 38 wherein at least one light source has a shape which is not symmetric about a reflection axis of the light guide.
40. A ranging apparatus as claimed in any of claims 34 to 39 wherein at least one light source is located within the light guide at a different depth to another light source.
41. A proximity sensor incorporating a ranging apparatus as claimed in any of claims 1 to 40.
42. A target identification apparatus incorporating a ranging apparatus as claimed in any of claims 1 to 40.
43. An intruder detection system incorporating a ranging apparatus as claimed in any of claims 1 to 40.
44. A biometric modelling apparatus incorporating a ranging apparatus as claimed in any of claims 1 to 40.
45. A document scanner comprising an imager and a ranging apparatus as claimed in any of claims 1 to 40, wherein the imager is adapted to process the range

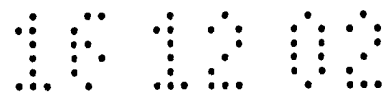

information from the document to determine the extent of curvature thereof and process the detected image to correct for any curvature.



INVESTOR IN PEOPLE

Application No: GB 0226242.6
Claims searched: all

Examiner: Matthew Perkins
Date of search: 18 August 2003

Patents Act 1977 : Search Report under Section 17

Documents considered to be relevant:

Category	Relevant to claims	Identity of document and passage or figure of particular relevance
X	1, 3, 14, 18, 20, 21, 24 & 41	GB 2372656 A (PETTY & PETTY) See whole document, particularly the abstract, page 4 line 9 to page 5 line 1 and page 17 line 24 to page 28 line 10.
X	1, 14, 17, 24, 25 & 41	US 6154279 A (THAYER) see abstract, column 1 line 64 to column 2 line 12 and column 7 lines 33 to 56.
X	1, 5, 6, 11, 12, 14, 18, 21, 27, 29, 30, 31 & 41	US 4294544 (ALTSCHULER) See abstract, column 2 lines 20 to 42, column 8 line 57 to column 9 line 38 and column 11 lines 52 to 57.

Categories:

X Document indicating lack of novelty or inventive step	A Document indicating technological background and/or state of the art
Y Document indicating lack of inventive step if combined with one or more other documents of same category	P Document published on or after the declared priority date but before the filing date of this invention
& Member of the same patent family	E Patent document published on or after, but with priority date earlier than, the filing date of this application.

Field of Search:

Search of GB, EP, WO & US patent documents classified in the following areas of the UKC^v:

G1A, H4D

Worldwide search of patent documents classified in the following areas of the IPC⁷:

G01B, G01S

The following online and other databases have been used in the preparation of this search report:

Online: WPI, EPODOC, PAJ