

AUSTRALIA

Patents Act 1990

NOTICE OF ENTITLEMENT
(To be filed before acceptance)

We, **EEV LIMITED**, of 106 Waterhouse Lane, Chelmsford, Essex CM1 2QX, England, being the applicant in respect of Application No. 43447/93 state the following:-

The Person nominated for the grant of the patent has entitlement from the actual inventor by assignment.

The person nominated for the grant of the patent is the applicant of the application listed in the declaration under Article 8 of the PCT.

The basic application listed on the request form is the first application made in a Convention country in respect of the invention.

EEV LIMITED

By our Patent Attorneys,
WATERMARK PATENT & TRADEMARK ATTORNEYS

.....
Stephen K. Plymin
Registered Patent Attorney

DATED 15 June 1995





AU9343447

(12) PATENT ABRIDGMENT (11) Document No. AU-B-43447/93
(19) AUSTRALIAN PATENT OFFICE (10) Acceptance No. 662431

- (54) Title
DISPLAYS
- International Patent Classification(s)
(51)⁵ **G09F 009/30 G09F 009/35**
- (21) Application No. : **43447/93** (22) Application Date : **09.06.93**
- (87) PCT Publication Number : **WO93/25992**
- (30) Priority Data
- (31) Number (32) Date (33) Country
9212219 09.06.92 GB UNITED KINGDOM
9302336 05.02.93 GB UNITED KINGDOM
- (43) Publication Date : **04.01.94**
- (44) Publication Date of Accepted Application : **31.08.95**
- (71) Applicant(s)
EEV LIMITED
- (72) Inventor(s)
IVAN CHAPLIN
- (74) Attorney or Agent
WATERMARK PATENT & TRADEMARK ATTORNEYS , Locked Bag 5, HAWTHORN VIC 3122
- (56) Prior Art Documents
DE 3148421
AU 64393/86 G09F 9/35
AU 68853/91 G02F 1/133 H04N 9/12 B09F 9/35
- (57) Claim

1. A display comprising a light emitter (1-4, 20) arranged to selectively project a ^{substantially collimated} beam of light (7), an electro-optical variable transmission cell (8, 25) located in front of the light emitter (1-4, 20) which is switchable between relatively more and relatively less transmissive states, characterised in that a reflective surface (8e, 29) is provided behind the cell (8, 25) which includes a hole (8f, 31) to allow the ^{substantially collimated} beam (7) to pass through the cell (8, 25), whereby ambient light is reflected from the reflective surface (8e, 29) when the cell is in a more transmissive state so as to enhance the observed contrast of the display.

(11) AU-B-43447/93
(10) 662431

-2-

2. A display according to claim 1, wherein the light emitter comprises the free end (4) of a length of optical fibre (3) the other end being located adjacent a light source, means being provided for selectively shuttering the emitted light to allow the beam to be selectively projected.



AU9343447

I.

<p>(51) International Patent Classification ⁵ : G09F 9/30, 9/35</p>	<p>A1</p>	<p>(11) International Publication Number: WO 93/25992 (43) International Publication Date: 23 December 1993 (23.12.93)</p>
<p>(21) International Application Number: PCT/GB93/01233 (22) International Filing Date: 9 June 1993 (09.06.93) (30) Priority data: 9212219.1 9 June 1992 (09.06.92) GB 9302336.4 5 February 1993 (05.02.93) GB (71) Applicant (for all designated States except US): EEV LIMITED [GB/GB]; 106 Waterhouse Lane, Chelmsford, Essex CM1 2AU (GB). (72) Inventor; and (75) Inventor/Applicant (for US only) : CHAPLIN, Ivan [GB/GB]; 33 Hulton Close, Boreham, Chelmsford, Essex CM3 3BU (GB). (74) Agent: COCKAYNE, Gillian; GEC Patent Department, Waterhouse Lane, Chelmsford, Essex CM1 2QX (GB).</p>		<p>(81) Designated States: AU, CA, JP, KR, NO, US, European patent (AT, BE, CH, DE, DK, ES, FR, GB, GR, IE, IT, LU, MC, NL, PT, SE). Published With international search report. Before the expiration of the time limit for amending the claims and to be republished in the event of the receipt of amendments.</p>

662431

(54) Title: DISPLAYS

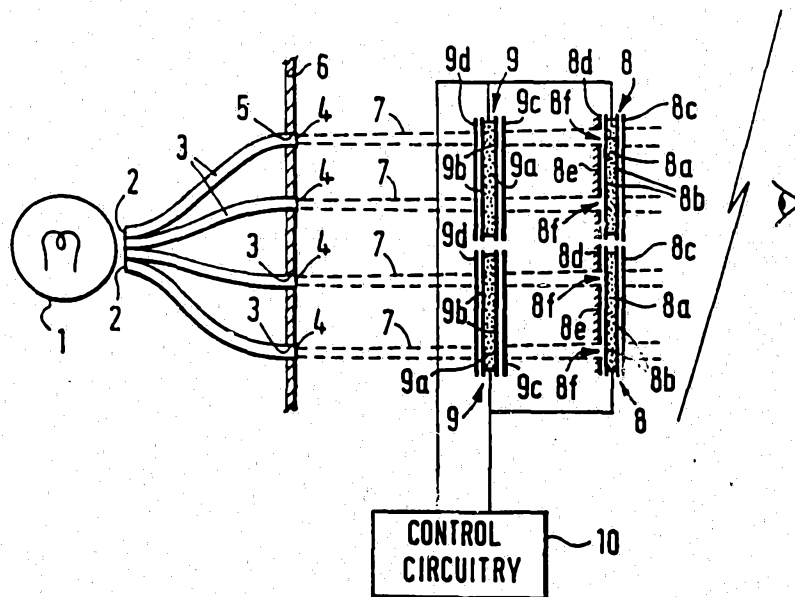

(57) Abstract

A switchable pixel of part of a display comprises a light source (1-4, 20) positioned behind a liquid crystal cell (8, 25). A reflective surface (8e, 29) is provided behind the cell (1-4, 20), a hole being present in the surface (8e, 29) which is aligned with the light beam (7) so that when the light source is emitting a beam of light, the cell can be switched to a relatively less transmissive state to allow ambient light to be reflected from the surface and enhance the contrast.

DISPLAYS

The invention relates to a display including one or more emitters which can be arranged to selectively project a beam of light to define symbols, e.g. alpha-numeric characters.

Such displays can be used as road signs for displaying information of a variable nature, for example the need for drivers to slow down, or to indicate the presence of fog, or other hazards.

GB-A-1,527,326 discloses an arrangement using a single bulb which is arranged to be maintained continually on and including a bundle of optical fibres whose remote ends are arranged in a matrix array and are each operative to project a narrow or substantially collimated beam of light. Light emitted by the optical fibres is selectively masked to define the required symbols by using a shutter arrangement comprising liquid crystal cells, positioned in front of each of the light sources.

It has also been proposed to use discrete independently switchable sources, such as light emitting diodes for each of the light emitters.

The main problem with both such types of device is that of ensuring that the contrast between light and dark is

as great as possible to enable the display to be read under high levels of ambient light, e.g. against direct sunlight.

This invention provides a display comprising a light emitter arranged to selectively project a ^{substantially collimated} beam of light, an electro-optical variable transmission cell located in front of the light emitter which is switchable between relatively more and relatively less transmissive states, characterised in that a reflective surface ^{is provided behind} ~~being provided is~~ the cell which includes a hole to allow ^{the} ~~the~~ ^{substantially collimated} beam to pass through the cell, whereby ambient light is reflected from the reflective surface when the cell is in a more transmissive state so as to enhance the observed contrast of the display.

Under low levels of ambient light the light emitter can have sufficient brightness for the display to be read, but when ambient light levels are high and when the light emitter may not have sufficient brightness, sufficient light can be reflected from the surface for the display to be clearly read.

The light emitter may comprise the free end of a length of optical fibre, the other end being located adjacent a light source, means being provided for selectively shuttering the emitted light to allow the beam to be selectively projected. Alternatively, the light emitter, such as a light emitting diode (L.E.D.), may be independently switchable.



In the case where the cell comprises a liquid crystal element, typically comprising liquid crystal material sandwiched between a pair of crossed polarisers, the rear most polariser includes a reflective coating.

Because the cell has to allow ambient light to travel both to and fro through the cell without significant attenuation, this can limit the thickness of the cell to the extent that there is insufficient contrast between the two states to adequately mask the light emitter. For this reason, when the display is of the shuttered type, a second electro-optical variable transmission cell is preferably disposed between the light emitter and the reflecting surface. Preferably the second cell is adapted such that the contrast between the relatively more and less transmissive states is greater than that of the first cell.

In order that the invention may be well understood, embodiments thereof will now be described with reference to the accompanying diagrammatic drawings, in which:-

Figure 1 is a schematic cross sectional view of part of a display according to one embodiment of the invention;

Figures 2(a) and 2(b) show schematically the display shown in Figure 1 as observed under low and high levels of ambient light respectively;

Figure 3 is a schematic cross-sectional view of part of a display according to another embodiment of the invention; and

Figure 4 is a view from the front of the display shown in Figure 3.

As shown in Figure 1, a display comprises one or more high brightness, e.g. quartz halogen, lamps 1. An end face 2 of each of a bundle of optical fibres 3 is located adjacent the lamp 1. The free ends 4 of the optical fibre 3 remote from the lamp 1 are located within apertures 5 in a support plate 6. Each of the optical fibres 3 is arranged to emit a substantially collimated beam of light 7 and for this purpose, the free ends 4 may include lenses (not shown). A shutter arrangement comprises, for each group of four optical fibres (best seen in Figure 2), a pair of liquid crystal cells 8, 9 disposed one in front of the other. Each cell comprises liquid crystal material 8a, 9a respectively sandwiched between a pair of plates 8b, 9b. Polariser 8c, 8d and 9c, 9d respectively are disposed one on either side of the pair of plates. Each plate, as is well known, carries electrodes typically of the translucent I.T.O. variety which are connected to control circuitry 10. Each cell is switchable between a relatively more transmissive state and a relatively less transmissive state so as to selectively mask and unmask each beam of light 7. The polariser 8d of each front cell 8 includes a silvered or

reflective coating 8e. Openings or holes 8f are provided in the reflective surface 8e to allow the beams of light 7 to pass unimpeded through the liquid crystal cell. Because ambient light must travel twice through the liquid crystal material 8a before returning to the observer, the material 8a is selected for maximum transmission while that used in the rear most cell 9 is selected for maximum contrast. In this way the front most cell 8 has a lower contrast between the masked and unmasked states and so is not able to attenuate as much light as the rear most cell 9. In a preferred construction, a T.N. cell is used for the front cell 8, and a Heilmair for the back cell 9. In use, when switched to the relatively more transmissive state, the cell 8 operates in both a reflective mode when allowing light to pass through the cell from where it is reflected back to the observer, and simultaneously in a transmissive mode by allowing the light beam 7 to pass through the cell.

A five by seven matrix array of such cells is shown schematically in Figures 2(a) and 2(b), each cell defining a pixel of an alpha numeric character. Under low levels of background illumination, as is shown schematically in Figure 2(a), the observer will merely see each individual light beam. However, high levels of background illumination will tend to swamp the light beams 7 and in such a case the majority of the light received by the observer will be that reflected from the reflective surface 8e.

Liquid crystal cells have an optimum viewing angle, ie. one in which the observed contrast between light and dark is maximised. In known liquid crystal elements this may be at an angle of between 40° and 50° away from and at each side of a normal extending at right angles to the plane of the element. The second cell 9 may be inclined at this angle so as to further enhance the observed contrast.

The display shown in Figures 3 and 4 is of a different type to that shown in Figure 1 in that the light emitters are independently switchable so that there is no need to provide a shuttering arrangement.

Each pixel comprises one or more, four as shown, light emitting diodes (L.E.D.'s) 20 mounted on a support plate 21. The L.E.D.'s 20 are mounted at small angles with respect to one another so that the display can be seen clearly over a range of viewing angles. In order to enhance the contrast of the display the outermost face 22 of the plate 21 surrounding the L.E.D.'s is coated with a non-reflective finish. The L.E.D.'s are each connected to control circuitry 24.

A liquid crystal element 25, also connected to the control circuitry, is disposed in front of the L.E.D.'s 20. Each element 25 comprises a liquid crystal material 26 sandwiched between a pair of translucent plates 27, 28. A reflective polariser 29 is provided on the rear most surface

of plate 28, a further polariser 30 being provided on the front. The polarisers 29, 30 have respective aligned circular openings 31 and a corresponding underlying region is provided in the element 25 which is devoid of liquid crystal material 26. The opening 31 is aligned with the L.E.D.'s and the element 25 is arranged so that when the L.E.D.'s are switched to an illuminated state the liquid crystal material is simultaneously switched to a relatively more transmissive state so that, in addition to the light from the L.E.D., light will be reflected from the reflective surface 29 back to the observer. When the L.E.D.'s are switched off, the liquid crystal element 4 is switched to a relatively less transmissive state, minimising reflection from surface 29.

The liquid crystal element 25 can be easily manufactured using well known silk screen printing techniques to define the region 31 on each of the plates 27, 28. The space between the plates 27, 28 is filled with the liquid crystal material 26 and the plates are then squeezed together. To provide for the evacuation of air from the region 31, a small passageway 32 may be provided (shown by dotted lines in Figure 4) which is then sealed.

If the L.E.D.'s are of sufficient brightness, and the liquid crystal material is of sufficient transmissivity, the void region 31 between the plates 27, 28 need not be provided.

CLAIMS

1. A display comprising a light emitter (1-4, 20) arranged to selectively project a ^{substantially collimated} beam of light (7), an electro-optical variable transmission cell (8, 25) located in front of the light emitter (1-4, 20) which is switchable between relatively more and relatively less transmissive states, characterised in that a reflective surface (8e, 29) is provided behind the cell (8, 25) which includes a hole (8f, 31) to allow the ^{substantially collimated} beam (7) to pass through the cell (8, 25), whereby ambient light is reflected from the reflective surface (8e, 29) when the cell is in a more transmissive state so as to enhance the observed contrast of the display.

2. A display according to claim 1, wherein the light emitter comprises the free end (4) of a length of optical fibre (3) the other end being located adjacent a light source, means being provided for selectively shuttering the emitted light to allow the beam to be selectively projected.

3. A display according to claim 1 or 2, wherein the cell (8) selectively shutters the beam (7) to allow the beam to be selectively projected.

4. A display according to claim 1, wherein the light emitter (20) is switchable to allow the beam to be



selectively projected.

5. A display according to claim 1 or 4, wherein the light emitter (20) comprises a light emitting diode.

6. A display according to any preceding claim, wherein the cell (8, 25) comprises a liquid crystal element.

7. A display according to claim 6, wherein the element comprises liquid crystal material (8a, 26) sandwiched between a pair of crossed polarisers (8c, 8d, 29, 30), the rear most one (8d, 29) of which includes a reflective coating.

8. A display according to claim 6 or 7, wherein the element (25) includes a region (31) aligned with the hole which is devoid of liquid crystal material.

9. A display according to claim 7 or 8 wherein the front most polariser (30) includes a further hole aligned with the hole (31) in the reflective surface (29).

10. A display according to any of claims 1-3, 6 or 7 comprising a second electro-optical variable transmission cell (9) disposed between the light emitter (1-4) and the reflective surface (8e) for selectively shuttering the emitted light.



11. A display according to claim 10, wherein the second cell (9) is adapted such that the contrast between the relatively more and less transmissive states is greater than that of the first cell.

12. A display according to any preceding claim, wherein a plurality of light emitters (1-4, 20) are provided for each cell (8, 25), the light emitters (1-4, 20) being disposed at a small angle with respect to one another so that the display may be observed over a range of viewing angles.

13. A display according to any preceding claim wherein a plurality of cells (8, 25) are arranged in an array, each cell defining a pixel of a symbol.

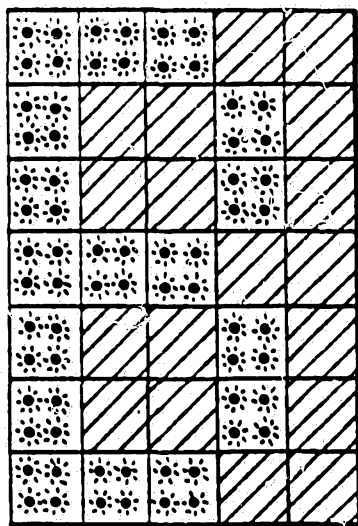
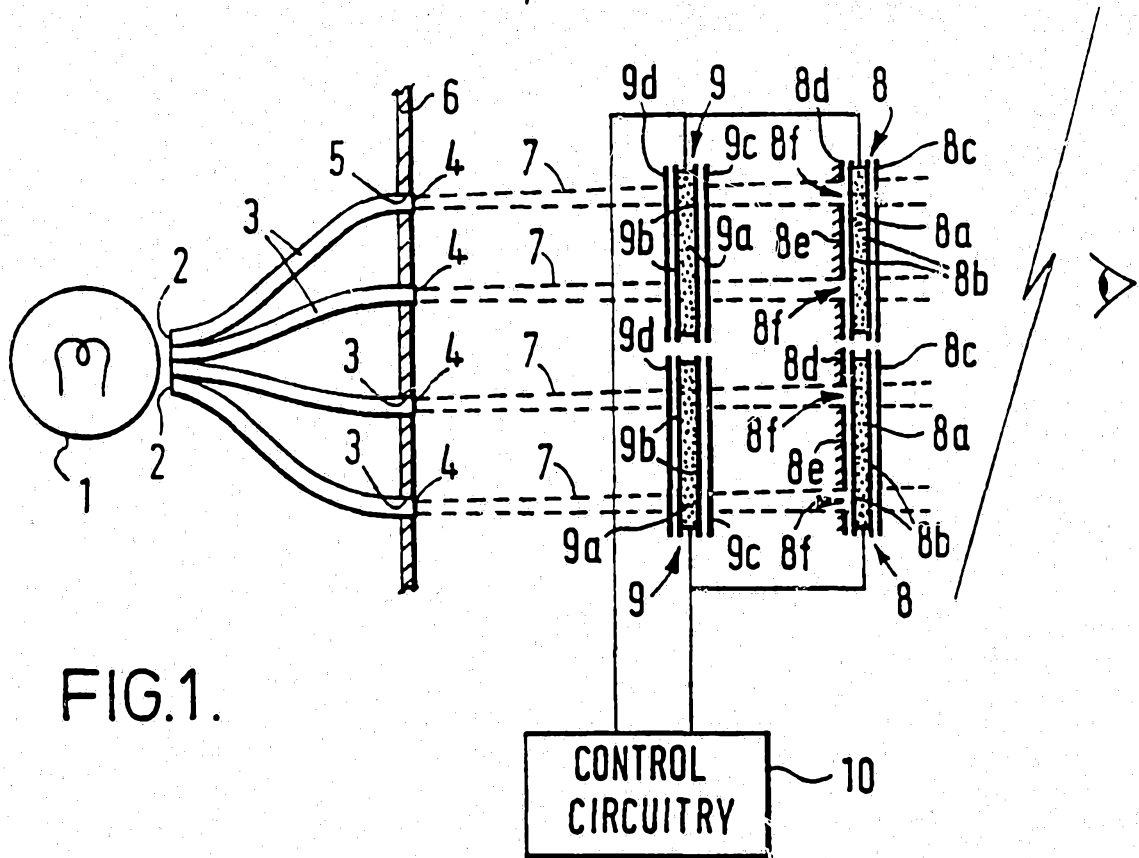

FIG. 2(a).

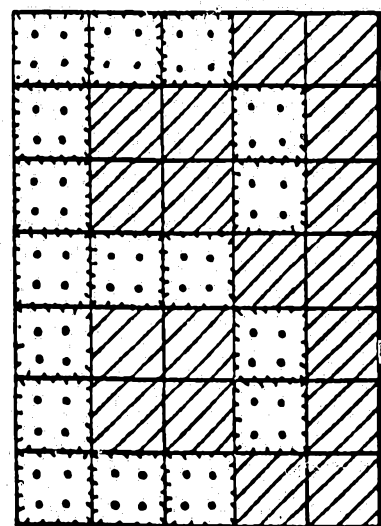

FIG. 2(b).

43447/93

2/2

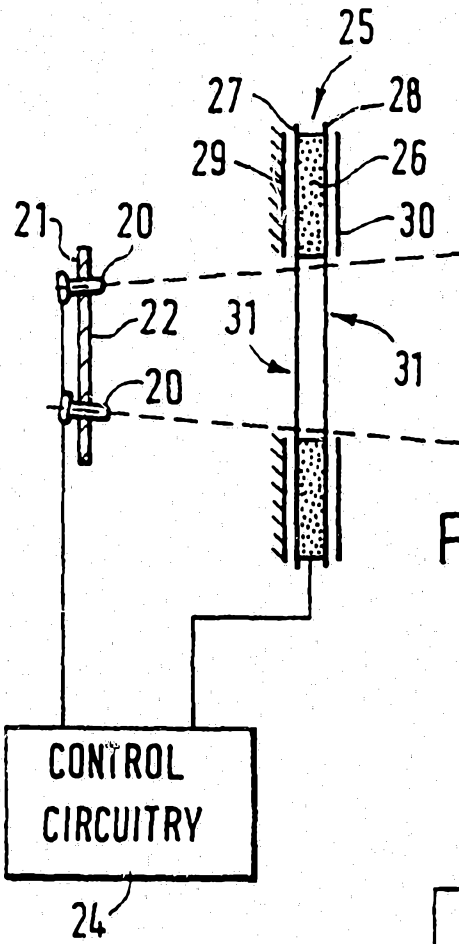

FIG. 3.

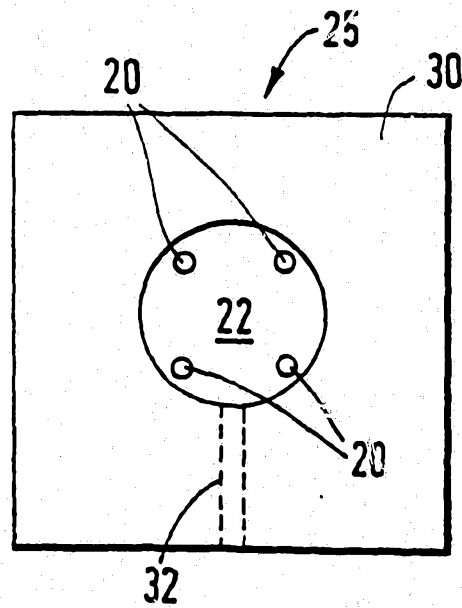

FIG. 4.

INTERNATIONAL SEARCH REPORT

PCT/GB 93/01233

International Application No

I. CLASSIFICATION OF SUBJECT MATTER (if several classification symbols apply, indicate all) ⁹		
According to International Patent Classification (IPC) or to both National Classification and IPC		
Int.Cl. 5 G09F9/30; G09F9/35		
II. FIELDS SEARCHED		
Minimum Documentation Searched ⁷		
Classification System	Classification Symbols	
Int.Cl. 5	G09F ; G02F	
Documentation Searched other than Minimum Documentation to the Extent that such Documents are Included in the Fields Searched ⁸		
III. DOCUMENTS CONSIDERED TO BE RELEVANT⁹		
Category ¹⁰	Citation of Document, ¹¹ with indication, where appropriate, of the relevant passages ¹²	Relevant to Claim No. ¹³
A	DE,A,3 148 421 (BLAUPUNKT) 21 July 1983 see page 5, line 6 - page 8, line 12; figures	1-3,6, 12,13
A	WO,A,8 607 178 (NCR CORP.) 4 December 1986 see page 3, line 14 - page 7, line 24; figures 1-3	1,3,5,6, 13
A	FR,A,2 614 717 (RAVANEL) 4 November 1988 see page 4, line 15 - page 9, line 5; figures 1-3,5,6	1,3,4,6, 13
	--- -/--	
<p>⁹ Special categories of cited documents: ¹⁰</p> <p>"A" document defining the general state of the art which is not considered to be of particular relevance</p> <p>"E" earlier document but published on or after the international filing date</p> <p>"L" document which may throw doubts on priority claim(s) or which is cited to establish the publication date of another citation or other special reason (as specified)</p> <p>"O" document referring to an oral disclosure, use, exhibition or other means</p> <p>"P" document published prior to the international filing date but later than the priority date claimed</p> <p>"T" later document published after the international filing date or priority date and not in conflict with the application but cited to understand the principle or theory underlying the invention</p> <p>"X" document of particular relevance; the claimed invention cannot be considered novel or cannot be considered to involve an inventive step</p> <p>"Y" document of particular relevance; the claimed invention cannot be considered to involve an inventive step when the document is combined with one or more other such documents, such combination being obvious to a person skilled in the art.</p> <p>"A" document member of the same patent family</p>		
IV. CERTIFICATION		
Date of the Actual Completion of the International Search	Date of Mailing of this International Search Report	
23 SEPTEMBER 1993	15. 10. 93	
International Searching Authority	Signature of Authorized Officer	
EUROPEAN PATENT OFFICE	TAYLOR P.	

III. DOCUMENTS CONSIDERED TO BE RELEVANT (CONTINUED FROM THE SECOND SHEET)		
Category °	Citation of Document, with indication, where appropriate, of the relevant passages	Relevant to Claim No.
A	GB,A,1 527 326 (STC LTD.) 4 October 1978 cited in the application see page 1, line 73 - page 2, line 15; figure 2 ---	1,2,7,13
A	ENGINEERING vol. 223, no. 6, June 1983, LONDON, GB pages 472 - 475 J. FERRARI 'Mimic diagrams are easier on the eye' see page 473, figure see page 475, left column, line 2 - page 475, middle column, line 45 -----	1,3,6,13

**ANNEX TO THE INTERNATIONAL SEARCH REPORT
ON INTERNATIONAL PATENT APPLICATION NO.**

GB 9301233
SA 75332

This annex lists the patent family members relating to the patent documents cited in the above-mentioned international search report. The members are as contained in the European Patent Office EDP file on The European Patent Office is in no way liable for these particulars which are merely given for the purpose of information. 23/09/93

Patent document cited in search report	Publication date	Patent family member(s)	Publication date
DE-A-3148421	21-07-83	None	
WO-A-8607178	04-12-86	EP-A- 0225369 JP-T- 62502917	16-06-87 19-11-87
FR-A-2614717	04-11-88	None	
GB-A-1527326	04-10-78	None	