



US00D617821S

(12) **United States Design Patent**
Kaplan et al.

(10) **Patent No.:** **US D617,821 S**

(45) **Date of Patent:** **** Jun. 15, 2010**

(54) **DIGITAL VIDEO CAMERA WITH BUILT-IN CONNECTOR**

(57) **CLAIM**

The ornamental design for a digital video camera with built-in connector, as shown and described.

(75) Inventors: **Jonathan Kaplan**, San Francisco, CA (US); **John Louis Warpakowski Furlan**, Belmont, CA (US); **Ariel Braunstein**, San Francisco, CA (US); **Simon Fleming-Wood**, Oakland, CA (US); **Maarten Dinger**, San Francisco, CA (US); **Nasahn Adam Sheppard**, Mill Valley, CA (US); **Peter Michaelian**, Tappan, NY (US)

DESCRIPTION

FIG. 1 is a top, front and left side perspective view of the first embodiment of a digital video camera with built-in connector showing our new design;

FIG. 2 is a top, rear and right side perspective view thereof;

FIG. 3 is a top, front and left side perspective view thereof, with the connector being in an extended position;

FIG. 4 is a top, rear and right side perspective view with the connector being in an extended position;

FIG. 5 is a right side elevational view thereof;

FIG. 6 is a left side elevational view thereof, with the connector being in an extended position;

FIG. 7 is a top plan view thereof, with the connector being in an extended position;

FIG. 8 is a bottom plan view thereof, with the connector being in an extended position;

FIG. 9 is a front elevational view thereof, the connector being in an extended position;

FIG. 10 is a rear elevational view thereof, the connector being in an extended position;

FIG. 11 is a top, front and left side perspective view of the second embodiment of the digital video camera with built-in connector shown in FIG. 1, the only difference being the shape of the opening in the lower end of the left side. All other surfaces are the same as those of the first embodiment;

FIG. 12 is a top, front and left side perspective view of the second embodiment of the digital video camera shown in FIG. 3, the only difference being the shape of the opening in the lower end of the left side. All other surfaces are the same as those of the first embodiment; and,

FIG. 13 is a left side elevational view of the second embodiment of the digital video camera shown in FIG. 6, the only difference being the shape of the opening in the lower end of the left side. All other surfaces are the same as those of the first embodiment.

(73) Assignee: **Cisco Technology, Inc.**, San Jose, CA (US)

(**) Term: **14 Years**

(21) Appl. No.: **29/335,303**

(22) Filed: **Apr. 13, 2009**

(51) **LOC (9) Cl.** **16-01**

(52) **U.S. Cl.** **D16/202**

(58) **Field of Classification Search** **D16/200-204, D16/208, 218; 348/373-376; 358/909.1; 396/535-541**

See application file for complete search history.

(56) **References Cited**

U.S. PATENT DOCUMENTS

3,001,461 A	9/1961	Irwin
D296,551 S	7/1988	Mizogui
D384,964 S	10/1997	Ito et al.
D401,257 S	11/1998	Iino

(Continued)

OTHER PUBLICATIONS

Office Action, U.S. Appl. No. 29/327,559. Dated Apr. 28, 2009.

Office Action, U.S. Appl. No. 29/328,155, dated Jun. 24, 2009.

(Continued)

Primary Examiner—Adir Aronovich

(74) Attorney, Agent, or Firm—Patterson & Sheridan, LLP

1 Claim, 10 Drawing Sheets

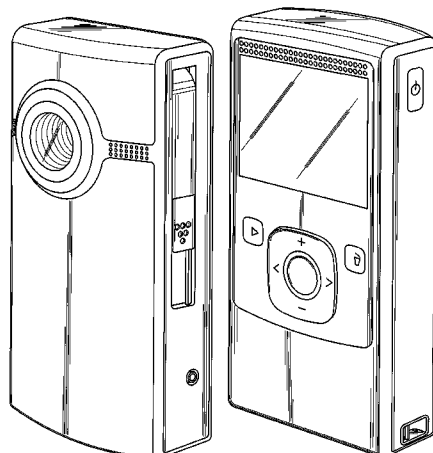

U.S. PATENT DOCUMENTS			OTHER PUBLICATIONS				
6,129,572	A	10/2000	Feldman et al.	2004/0201692	A1	10/2004	Parulski et al.
6,415,106	B2 *	7/2002	Hayashi et al. 396/85	2004/0212966	A1	10/2004	Fisher et al.
D463,426	S	9/2002	Cheng	2004/0263634	A1	12/2004	Kiuchi
6,449,438	B1	9/2002	Gennetten	2005/0037647	A1	2/2005	Le
D464,664	S	10/2002	Huang	2005/0050371	A1	3/2005	Ono
6,477,138	B1	11/2002	Cho et al.	2005/0060636	A1	3/2005	Mathe
D467,259	S	12/2002	Hung et al.	2005/0070225	A1	3/2005	Lee
6,577,337	B1	6/2003	Kang	2005/0079738	A1	4/2005	Ahn
6,587,151	B1	7/2003	Cipolla et al.	2005/0099499	A1	5/2005	Braunstein et al.
6,628,325	B1	9/2003	Steinberg et al.	2005/0114587	A1	5/2005	Chou et al.
D482,694	S	11/2003	Chen	2005/0157459	A1	7/2005	Yin et al.
6,683,653	B1 *	1/2004	Miyake et al. 348/373	2005/0162508	A1	7/2005	Basmadjian et al.
D487,458	S	3/2004	Gentil et al.	2005/0174710	A1	8/2005	Masui et al.
6,720,998	B1	4/2004	Kim	2005/0177661	A1	8/2005	Loo
6,727,952	B1	4/2004	Hirata et al.	2005/0210195	A1	9/2005	Teicher et al.
6,731,956	B2	5/2004	Hanna et al.	2005/0237356	A1	10/2005	Lee
6,743,030	B2	6/2004	Lin et al.	2005/0237398	A1	10/2005	Fujii et al.
6,750,902	B1	6/2004	Steinberg et al.	2005/0253930	A1	11/2005	Endo et al.
6,784,941	B1	8/2004	Su et al.	2005/0265099	A1	12/2005	Hosokawa
6,806,978	B1	10/2004	Tamura et al.	2005/0280732	A1	12/2005	Misawa
6,819,355	B1	11/2004	Niikawa	2005/0285963	A1	12/2005	Misawa et al.
6,829,004	B1	12/2004	Abe	2006/0015662	A1	1/2006	Dietz et al.
6,833,863	B1	12/2004	Clemens	2006/0036784	A1	2/2006	Loo
6,873,356	B1	3/2005	Kanbe et al.	2006/0064185	A1	3/2006	Yeh
6,941,021	B2	9/2005	Goldstein et al.	2006/0075411	A1	4/2006	Yeh
6,950,142	B2	9/2005	Soumi et al.	2006/0092302	A1	5/2006	Lee
6,992,721	B1	1/2006	Kambayashi et al.	2006/0103737	A1	5/2006	Okisu et al.
7,004,780	B1	2/2006	Wang	2006/0109349	A1	5/2006	Takashima
7,025,275	B2	4/2006	Huang et al.	2006/0216973	A1	9/2006	Walmsley et al.
D527,403	S *	8/2006	Byun et al. D16/202	2006/0223369	A1	10/2006	Zheng
7,126,629	B1	10/2006	Braunstein et al.	2007/0022232	A1	1/2007	Bhakta et al.
D531,581	S	11/2006	Wang et al.	2007/0066130	A1	3/2007	Mori et al.
7,142,244	B1	11/2006	Barbeau	2007/0093093	A1	4/2007	Lev et al.
D552,141	S	10/2007	Kaplan et al.	2007/0115387	A1 *	5/2007	Ho 348/375
7,286,182	B2	10/2007	Silverbrook et al.	2007/0242066	A1	10/2007	Rosenthal
7,286,256	B2	10/2007	Herbert	2008/0014829	A1	1/2008	Dyer et al.
7,349,010	B2	3/2008	Bryant et al.				
7,385,630	B2	6/2008	King et al.				
7,389,878	B1	6/2008	Torrico				
D577,019	S	9/2008	Udagawa et al.				
7,432,977	B2 *	10/2008	Chiang 348/373				
7,443,418	B2	10/2008	Bryant et al.				
D579,933	S	11/2008	Deguchi				
D591,321	S	4/2009	Sheppard et al.				
D599,833	S *	9/2009	Dohi et al. D16/202				
D607,479	S *	1/2010	Yu D16/202				
D608,813	S *	1/2010	Hong et al. D16/218				
2002/0101515	A1	8/2002	Yoshida et al.				
2003/0207611	A1	11/2003	Lin et al.				
2004/0145676	A1	7/2004	Lin				
2004/0155966	A1	8/2004	Jang et al.				

Benderoff, Eric. "This Videocam is Easy to Keep at Fingertips," Chicago Tribune, May 17, 2006.

Colker, David. "Gizmo Report: Small Device Creates Instant Video," Los Angeles Times, May 26, 2006.

Graham, Jefferson. "New breed of tiny camcorder simple to use, easy on wallet," USA Today, May 1, 2006.

Mossberg, et al. "The Video Camera Revised," Wall Street Journal, May 3, 2006.

Pure Digital "Point and Shoot" Camcorder, released May 1, 2006 (pp. 1-7).

Pure Digital Flip Video Ultra Series, released Sep. 12, 2007 (pp. 1-7).

Pure Digital Flip Video, released May 1, 2007 (1 page).

U.S. Appl. No. 11/497,039, filed Jul. 31, 2006.

* cited by examiner

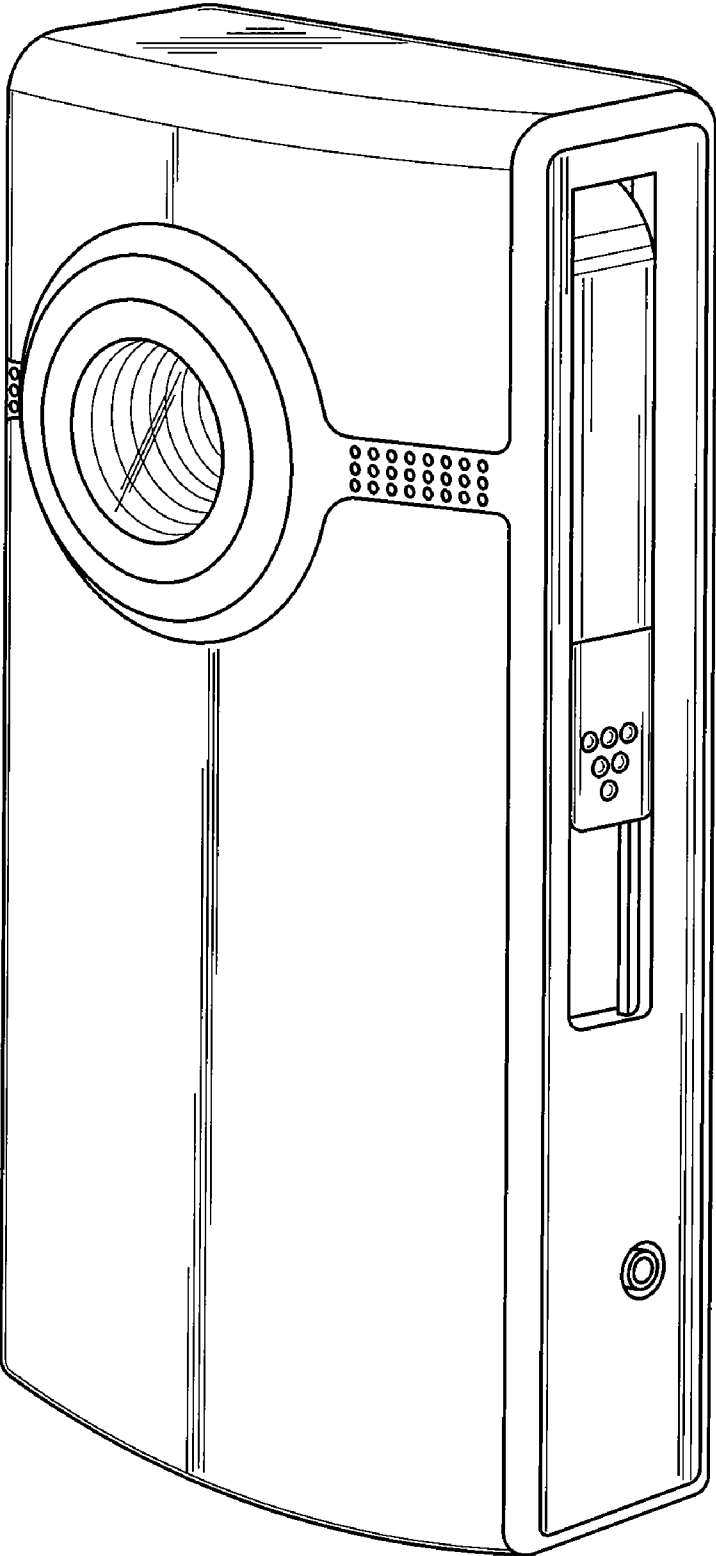

FIG. 1

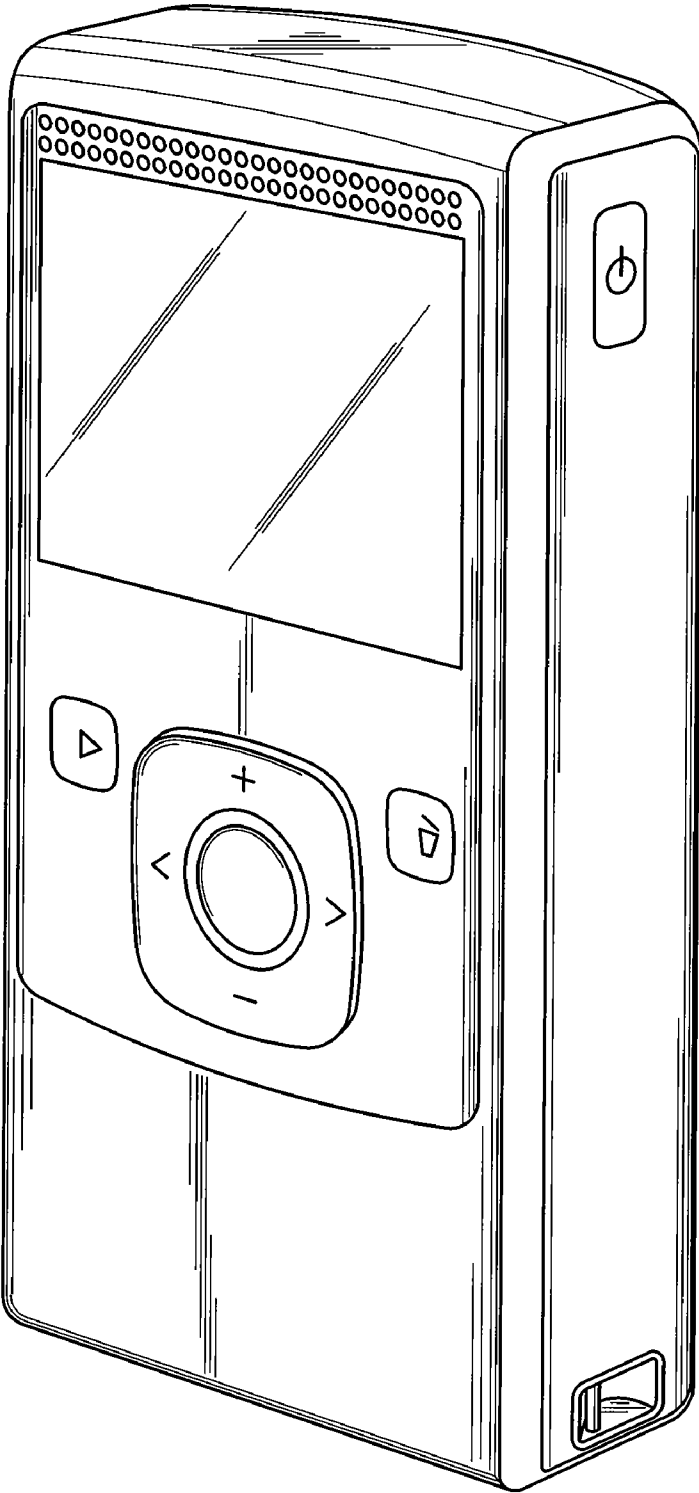

FIG.2

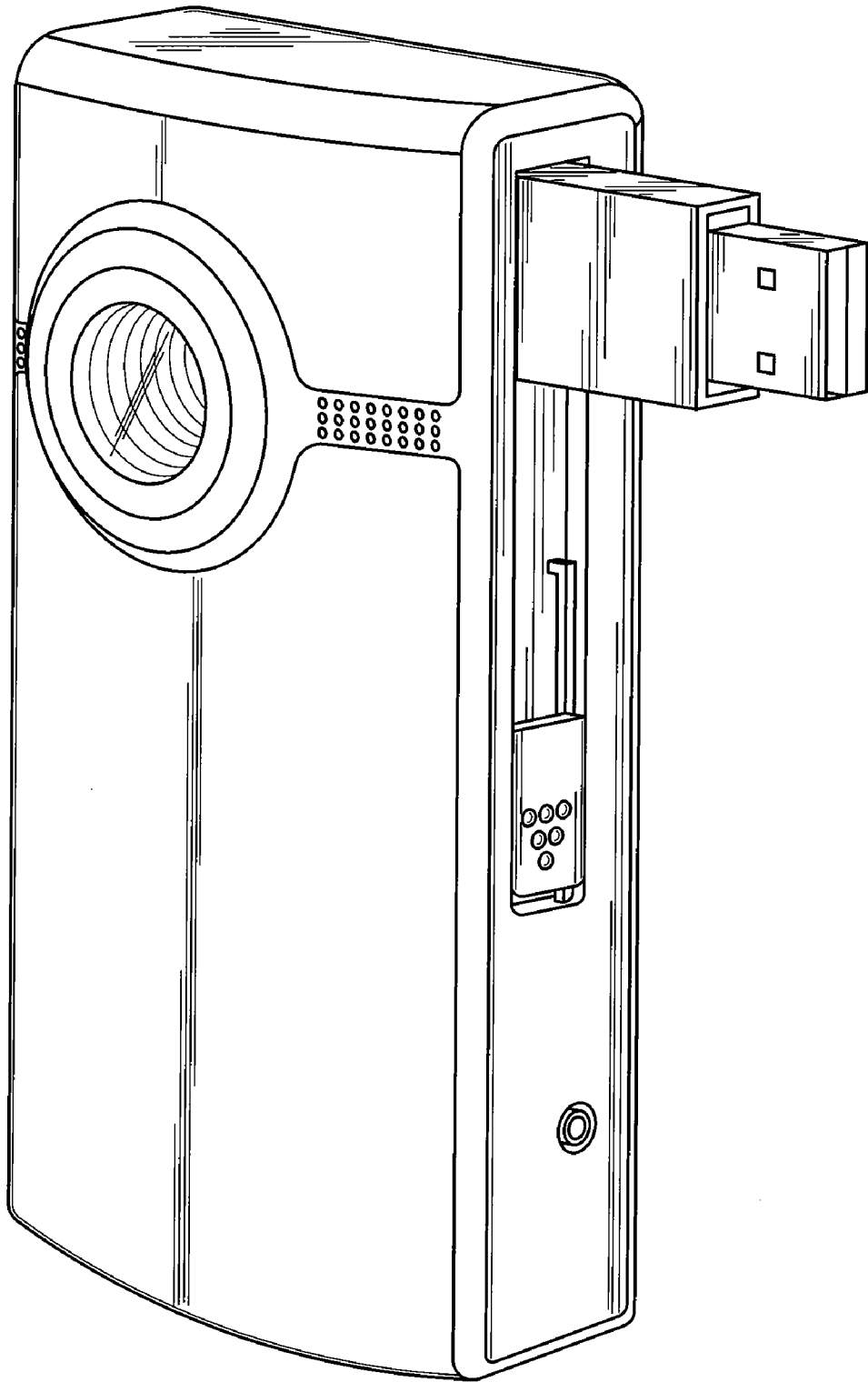

FIG.3

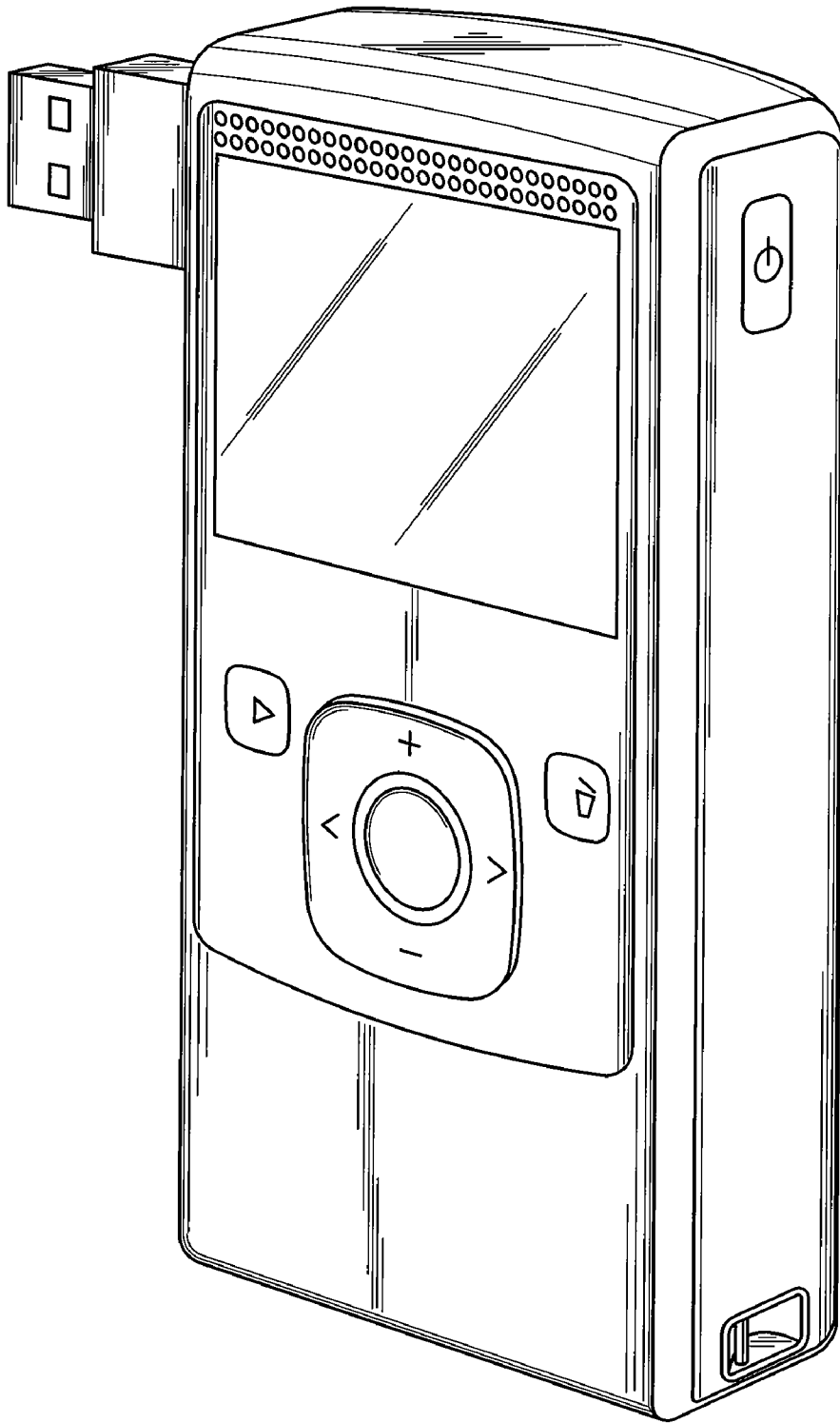

FIG. 4

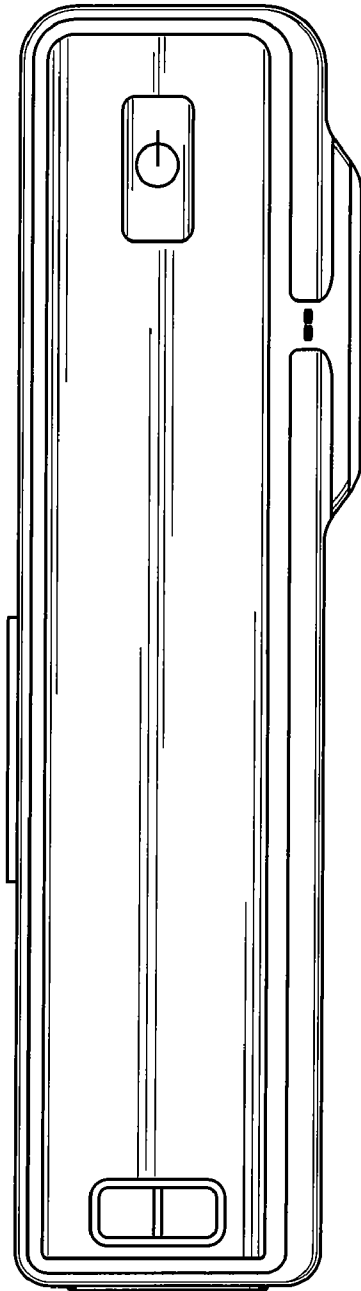

FIG. 5

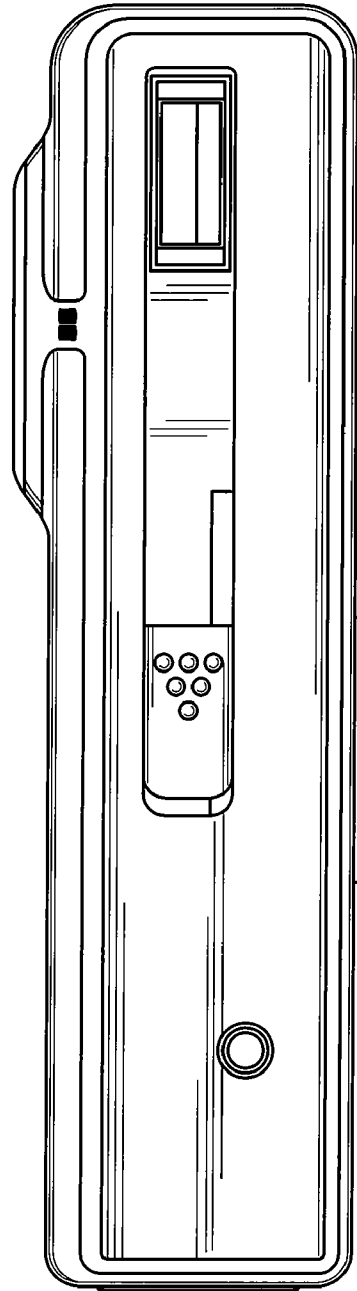

FIG. 6

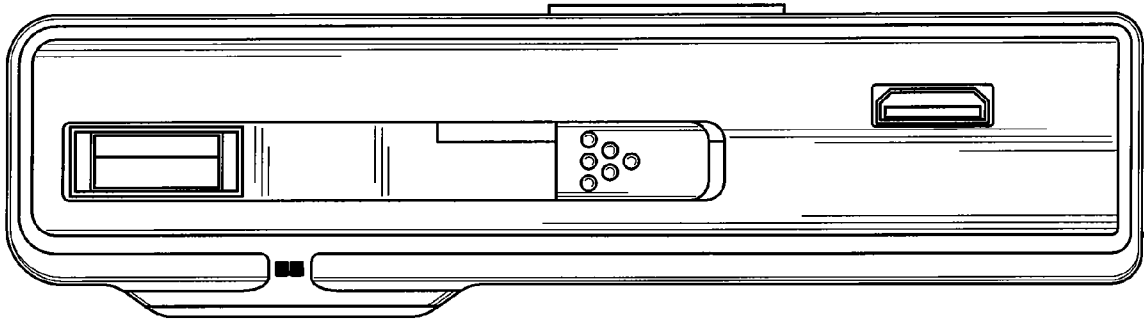

FIG. 13

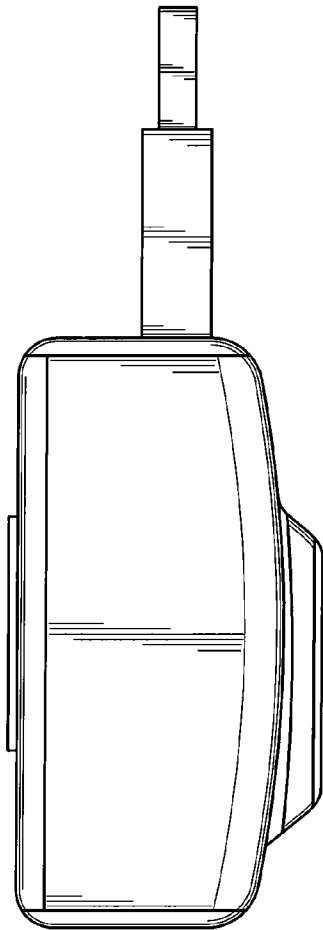

FIG. 7

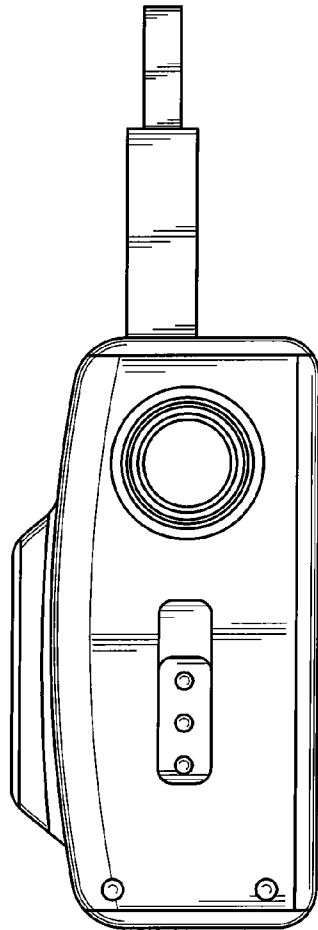

FIG. 8

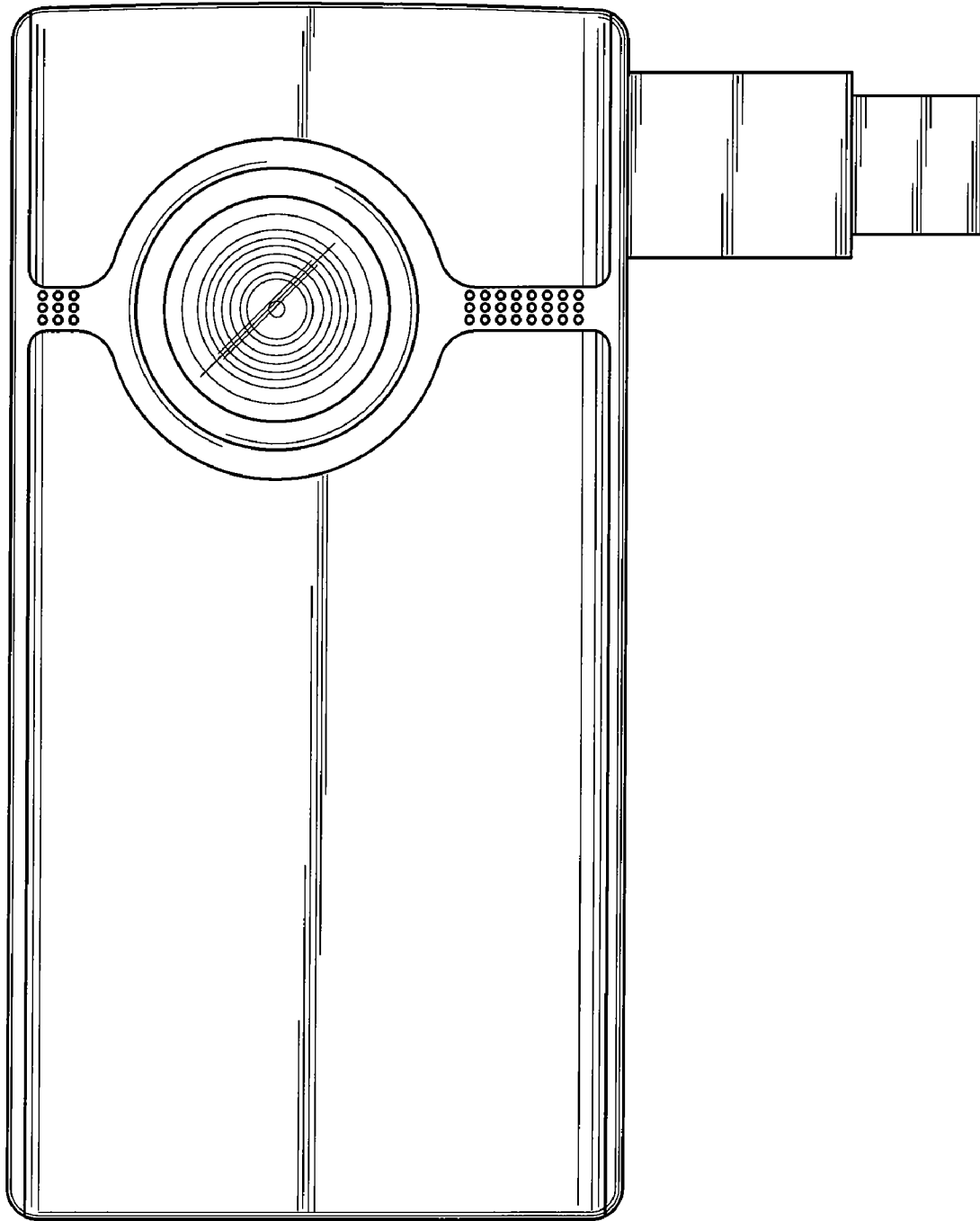

FIG.9

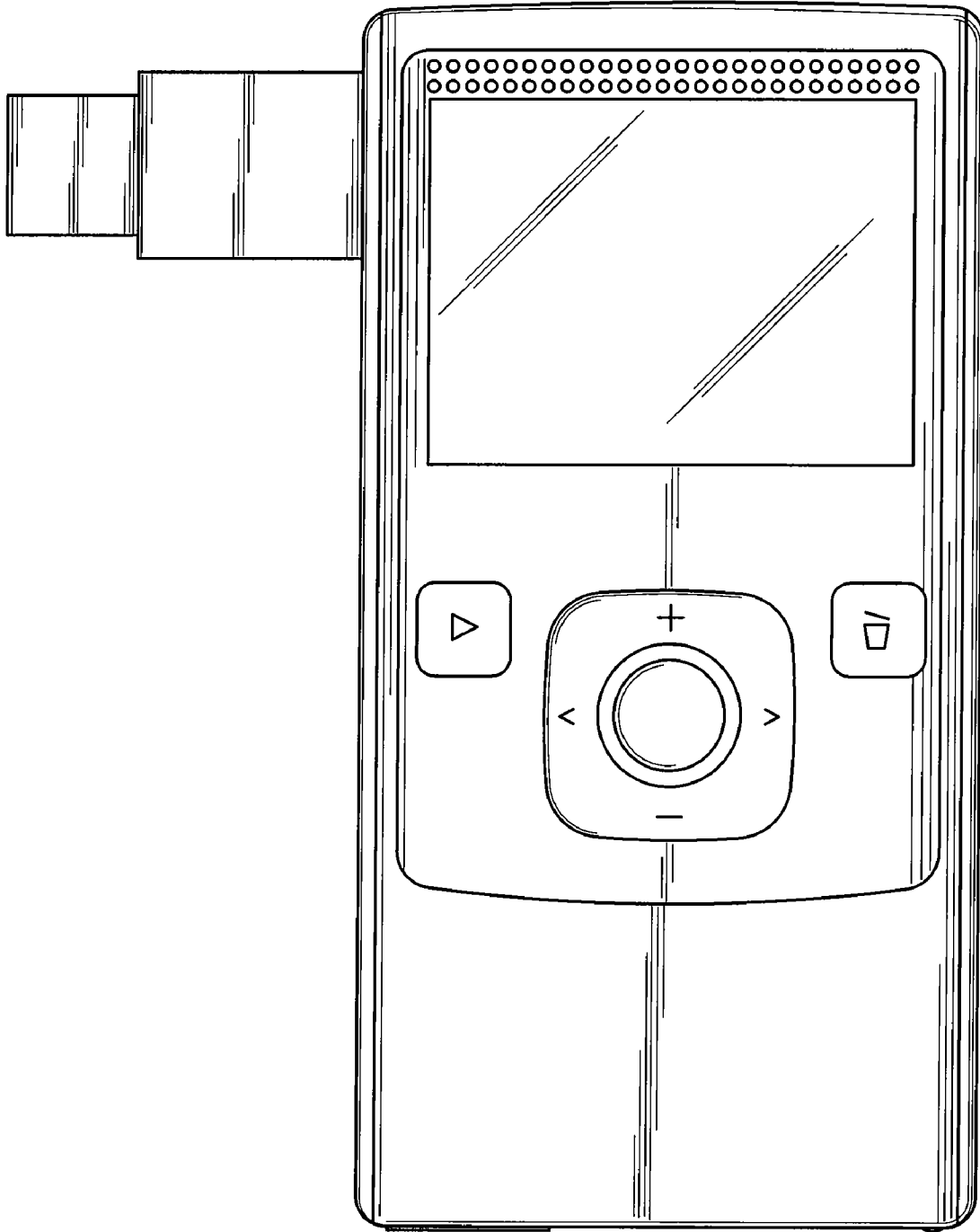

FIG. 10

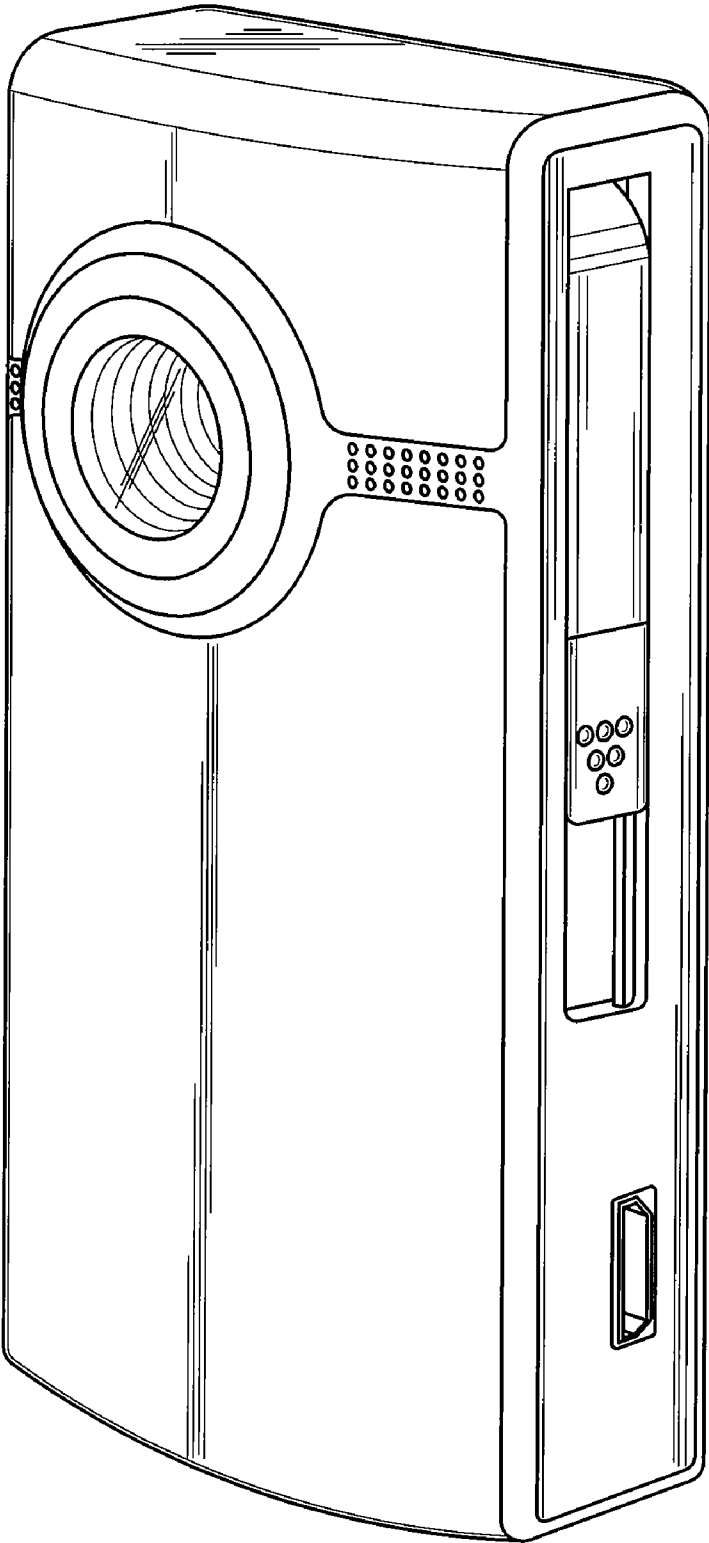

FIG. 11

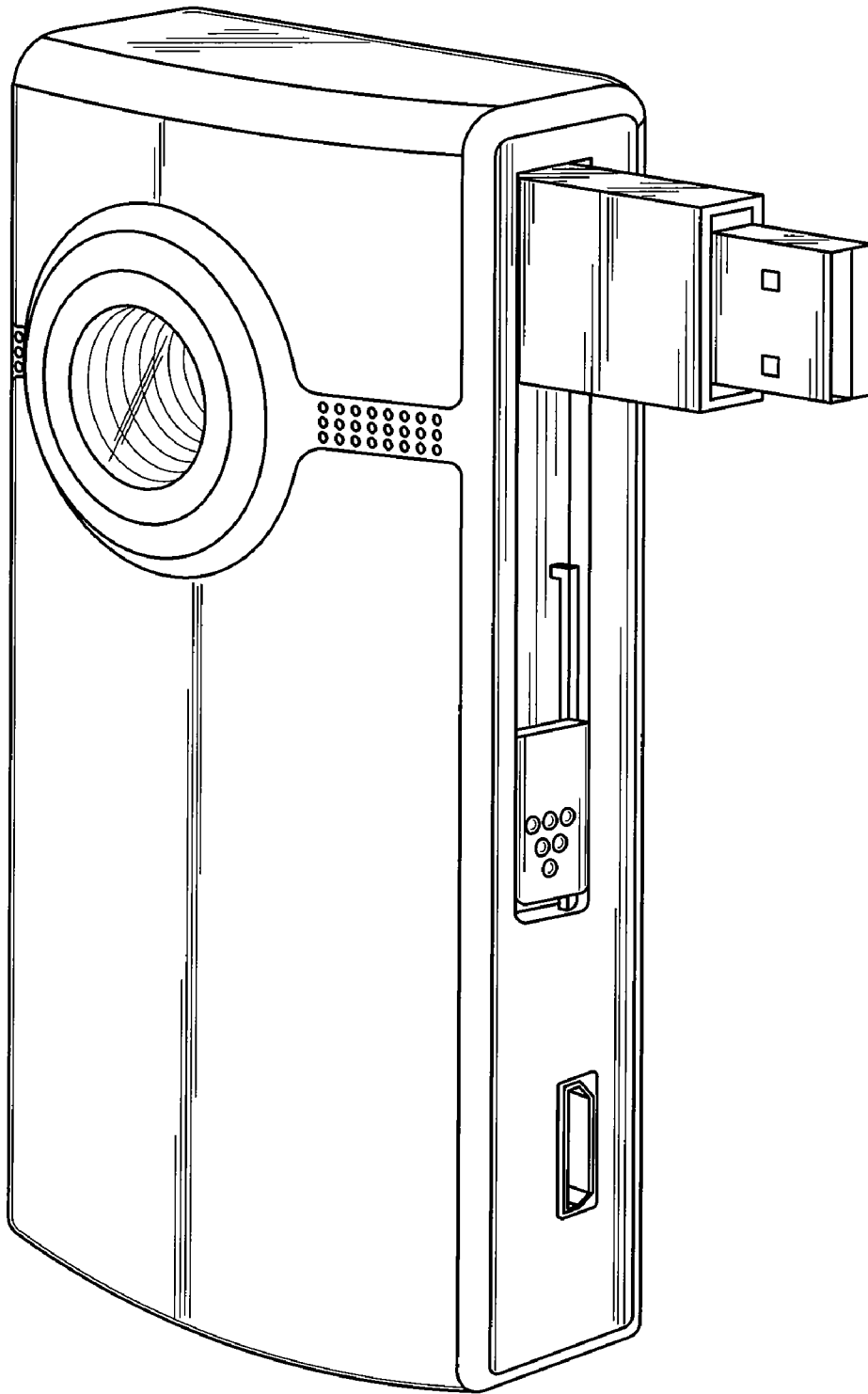

FIG.12