



- (51) **International Patent Classification:**  
*F03D 11/00* (2006.01)     *F03D 3/06* (2006.01)  
*F03D 1/06* (2006.01)
- (21) **International Application Number:**  
PCT/US2011/026372
- (22) **International Filing Date:**  
25 February 2011 (25.02.2011)
- (25) **Filing Language:** English
- (26) **Publication Language:** English
- (30) **Priority Data:**  
61/308,219     25 February 2010 (25.02.2010)     US
- (71) **Applicant (for all designated States except US):** THE REGENTS OF THE UNIVERSITY OF CALIFORNIA [US/US]; 1111 Franklin Street, Oakland, CA 94607-5200 (US).
- (72) **Inventors; and**
- (75) **Inventors/Applicants (for US only):** WIRZ, Richard, E. [US/US]; 126 W. Manor St., Altadena, CA 91001 (US). ASPE, Sebastian [US/US]; 3221 Carter Ave., #418, Marina del Rey, CA 90292 (US).
- (74) **Agent:** CISLO, Daniel, M.; Cislo & Thomas LLP, 1333 2nd Street, Suite No. 500, Santa Monica, CA 90401 (US).

- (81) **Designated States (unless otherwise indicated, for every kind of national protection available):** AE, AG, AL, AM, AO, AT, AU, AZ, BA, BB, BG, BH, BR, BW, BY, BZ, CA, CH, CL, CN, CO, CR, CU, CZ, DE, DK, DM, DO, DZ, EC, EE, EG, ES, FI, GB, GD, GE, GH, GM, GT, HN, HR, HU, ID, IL, IN, IS, JP, KE, KG, KM, KN, KP, KR, KZ, LA, LC, LK, LR, LS, LT, LU, LY, MA, MD, ME, MG, MK, MN, MW, MX, MY, MZ, NA, NG, NI, NO, NZ, OM, PE, PG, PH, PL, PT, RO, RS, RU, SC, SD, SE, SG, SK, SL, SM, ST, SV, SY, TH, TJ, TM, TN, TR, TT, TZ, UA, UG, US, UZ, VC, VN, ZA, ZM, ZW.
- (84) **Designated States (unless otherwise indicated, for every kind of regional protection available):** ARIPO (BW, GH, GM, KE, LR, LS, MW, MZ, NA, SD, SL, SZ, TZ, UG, ZM, ZW), Eurasian (AM, AZ, BY, KG, KZ, MD, RU, TJ, TM), European (AL, AT, BE, BG, CH, CY, CZ, DE, DK, EE, ES, FI, FR, GB, GR, HR, HU, IE, IS, IT, LT, LU, LV, MC, MK, MT, NL, NO, PL, PT, RO, RS, SE, SI, SK, SM, TR), OAPI (BF, BJ, CF, CG, CI, CM, GA, GN, GQ, GW, ML, MR, NE, SN, TD, TG).

**Declarations under Rule 4.17:**

— of inventorship (Rule 4.17(iv))

**Published:**

— without international search report and to be republished upon receipt of that report (Rule 48.2(g))

(54) **Title:** INTEGRATED WIND TURBINE

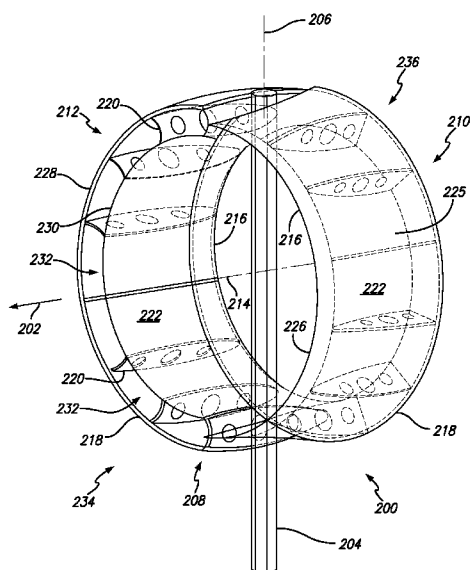

FIG. 3

(57) **Abstract:** An integrated wind turbine. Each turbine blade has a flexible skin. Openings in the leading edge lead to one or more inflation chambers for ram air inflation during operation. A pivotal connection with the support post allows the plurality of turbine blades to yaw such that the rotor plane remains substantially perpendicular to the wind direction. The wind turbine may also include self-deploying drag vanes that extend away from the flexible skin when the wind speed is greater than the speed of the airfoil.

WO 2011/106737 A2

## INTEGRATED WIND TURBINE

## CROSS-REFERENCES TO RELATED APPLICATIONS

**[0001]** This patent application claims the benefit of United States Provisional Patent Application Serial Number 61/308,219 filed February 25, 2010 for Integrated Wind Turbine. That application is incorporated here by this reference.

## TECHNICAL FIELD

**[0002]** This invention relates to designs for wind turbines.

## BACKGROUND ART

**[0003]** Currently, the integration of wind turbines into urban and suburban environments (non-traditional placement near or on buildings) is hindered by noise, structural vibrations, installation costs, low-quality (weak and variable) winds, safety, and low performance.

**[0004]** Most modern wind turbines seek an increased power production by means of larger rotor sizes. This resulted in the need for dedicated wind farms for large wind turbines. Hence, the current approach to increasing power production by making larger rotors does not satisfy the needs of building-integrated wind turbines. The weight of the blades directly affects the inertia of the rotor and the loads at the shaft. Therefore, most of the challenges faced by building-integrated wind turbines are due to the turbine weight and size.

**[0005]** Another challenge in current wind turbine design is the “starting” problem. Large turbines require energy expenditure to begin rotating in light and moderate winds, as well as yaw control in the case of Horizontal Axis Wind Turbines (HAWTs). Vertical Axis Wind Turbines (VAWTs) can make use of winds from all directions and are structurally less demanding than HAWTs. But VAWTs that are lift-driven are not self-starting even in strong winds, and must first be sped up to a certain angular velocity before the aerodynamic forces can drive the shaft’s

rotation. Drag-driven VAWTs are self-starting, but their efficiency is inferior to the lift-driven turbines.

**[0006]** In addition, the elevated costs of currently available micro-wind turbines and their installation outweigh the benefits until the investment is amortized years later.

**[0007]** Accordingly, making use of wind in areas not specifically dedicated to wind energy and empowering lift-driven devices to self-start will benefit wind turbine performance by targeting key aspects that determine their efficiency.

#### DISCLOSURE OF INVENTION

**[0008]** The present invention is directed to an integrated wind turbine. One aspect of the invention can be described as a horizontal axis wind turbine in relation to a wind direction. The wind turbine includes a support post, a shaft, and a plurality of turbine blades.

**[0009]** The shaft is pivotally connected to the support post at the upwind portion of the shaft. The shaft also defines an axis of rotation. The plurality of turbine blades extends radially from the downwind portion of the shaft, and the turbine blades are equally spaced radially about the shaft.

**[0010]** Each turbine blade has a flexible skin and an internal skeleton within the flexible skin. The flexible skin includes a leading edge, an upper surface, and a lower surface. The leading edge has one or more openings. The upper surface, the lower surface, and the internal skeleton form a plurality of inflation chambers. Each opening in the leading edge leads to one or more of the inflation chambers for ram air inflation during operation. In the inflated condition, the plurality of inflation chambers is filled with air and the flexible skin, supported by the internal skeleton, has a blade structure.

**[0011]** The pivotal connection between the shaft and the support post allows the plurality of turbine blades to yaw about the axis of rotation such that the rotor plane remains substantially perpendicular to the wind direction.

**[0012]** Another aspect of the invention can be described as a vertical axis wind turbine in relation to a wind stream having a wind speed. The wind turbine includes a support post defining an axis of rotation and an inflatable airfoil rotatably connected to the support post.

**[0013]** The right half and the left half of the airfoil are each semi-toroidal. Each also has a leading edge, a trailing edge, a plurality of ribs, and a flexible skin.

**[0014]** The leading edge has a leading edge wire. The trailing edge has an outer trailing edge wire and an inner trailing edge wire. The plurality of ribs connects the leading edge to the trailing edge.

**[0015]** The flexible skin extends from the outer trailing edge wire around the leading edge to the inner trailing edge wire and generally covers each of the plurality of ribs, thereby forming a semi-toroidal airfoil profile. In a version of the invention, the flexible skin does not extend directly from that outer trailing edge wire to the inner trailing edge wire, thereby leaving the trailing edge open and forming an inflation cavity.

**[0016]** The right half and the left half are symmetrical about and join at the support post. The right half is oriented such that the right half leading edge is on a first side of the wind turbine and the right half trailing edge is on an opposite second side of the wind turbine. The left half is oriented such that the left half leading edge is on the second side of the wind turbine and the left half trailing edge is on the first side. The right half leading edge and the left half trailing edge generally form a circular edge on the first side of the wind turbine. The left half leading edge and the right half trailing edge generally form a circular edge on the second side of the wind turbine.

**[0017]** The wind turbine may also include a plurality of self-deploying drag vanes connected to an outside surface of the flexible skin. The drag vanes extend away from the flexible skin when the wind speed is greater than the tangential speed component of the airfoil.

**[0018]** In yet another aspect, the invention can be described as a continuous response, vertical axis wind turbine in relation to a wind stream having a wind speed. The wind turbine has a support post that defines an axis of rotation. The wind turbine also has an inflatable airfoil rotatably connected to the support post and rotating about the axis of rotation at an angular velocity, which has a tangential speed component. The airfoil preferably has a pair of helical blades, although it could have three or more blades.

**[0019]** Each helical blade includes a leading edge, a first trailing edge, a second trailing edge, a flexible skin, and a plurality of ribs. The leading edge forms a helix that is closer to the support post than a helix formed by the first trailing edge and a helix formed by the second trailing edge.

**[0020]** The flexible skin extends from the first trailing edge to the leading edge to form an upper airfoil surface. The flexible skin also extends from the leading edge to the second trailing edge and forms a lower airfoil surface. In a version of the invention, the flexible skin does not extend directly from the first trailing edge to the second trailing edge, thereby leaving the trailing edge open.

**[0021]** The plurality of ribs connects the leading edge to the first trailing edge and the second trailing edge. Each rib extends radially with respect to the support post and is perpendicular to the helix formed by the first trailing edge and the helix formed by the second trailing edge. The plurality of ribs and the flexible skin form a plurality of inflation cavities.

**[0022]** In the inflated condition of the helical blade, the combination of the leading edge, first trailing edge, second trailing edge, flexible skin, and plurality of ribs gives the helical blade and airfoil profile.

**[0023]** In a version of the invention, the continuous response, vertical axis wind turbine also includes a plurality of self-deploying drag vanes connected to the upper airfoil surface and/or the lower airfoil surface. The drag vanes extend from the upper airfoil surface and the lower airfoil surface when the wind speed is greater than the tangential speed component of the airfoil. The drag vanes retract against the respective upper airfoil surface and lower airfoil surface when the tangential speed component of the airfoil is greater than the wind speed.

#### BRIEF DESCRIPTION OF DRAWINGS

**[0024]** Figure 1 is a depiction of a self-yawing, self-starting, parafoil HAWT.

**[0025]** Figure 2 is a HAWT with parafoil blades.

**[0026]** Figure 3 is a schematic of a collapsible parafoil VAWT with a skeletal structure. The hidden features are shown in broken lines.

**[0027]** Figure 4 is a depiction of a continuous response, parafoil VAWT.

**[0028]** Figure 5 is depiction of a drag-start method incorporating drag vanes.

**[0029]** Figure 6 is a depiction of drag-start airfoils incorporating drag vanes or ram air inflation.

#### BEST MODE FOR CARRYING OUT THE INVENTION

**[0030]** The detailed description set forth below in connection with the appended drawings is intended as a description of presently-preferred embodiments of the invention and is not intended to represent the only forms in which the present invention may be constructed or utilized. The description sets forth the functions and the sequence of steps for constructing and operating the

invention in connection with the illustrated embodiments. However, it is to be understood that the same or equivalent functions and sequences may be accomplished by different embodiments that are also intended to be encompassed within the spirit and scope of the invention.

**[0031]** The present invention is directed to an improved design for a wind turbine, and there are two principal aspects to the disclosed concept. One aspect reduces wind turbine rotor weight by using a parafoil-type airfoil. The other aspect uses a “drag-start” method. Each of these aspects is discussed in detail below.

**[0032]** As an initial matter, but the term “parafoil” will be used throughout this document instead of the more cumbersome term “parafoil-like.” But it should be noted that, unless evident from the context, this term does not refer specifically to the traditional parafoil used as a parachute or kite since, among other things, it does not include suspension lines. Rather, the term “parafoil” refers to that part of the traditional parafoil which is a nonrigid or semirigid airfoil inflated by the wind.

**[0033]** The first aspect involves a parafoil design to result in significant reduction in blade mass over state-of-the-art designs. Preferably, the parafoil has a flexible skin, and it is internally supported by a cage-like or skeletal structure. Also, the airfoil preferably has inflatable/collapsible characteristics and allow varying geometries along the blade’s circumferential path. The improvement benefits both HAWTs and VAWTs, such as those depicted in the example configurations shown in Figures 1–6.

**[0034]** The parafoil design addresses the challenges for wind turbines (VAWT and HAWT) by reducing the turbine’s structural weight. The reduced weight of the blades helps to ease the concerns noted above since both the inertial and dynamic loads are reduced. For the general wind turbine, this invention is advantageous because it will allow turbines to self-yaw, make use of

lower quality winds, and gracefully collapse upon impact, such as by a bird, bat, or pedestrian. Refer to Figure 1 and Figure 2 for examples of a self-yawing parafoil HAWT designs.

**[0035]** The second aspect makes use of a “drag-start” method to start the rotation of lift-driven wind turbines. The drag force required to start the rotation is obtained from the returning airfoil’s geometry (as shown by the bottom airfoil in Figure 6) by means of deployable flaps, vanes, or cavities. These drag creating devices inflate or extend when the air flows from the airfoil’s trailing edge to its leading edge, and retract when the airflow favors the “clean” configuration from the leading edge to the trailing edge. The devices may be made from flexible or rigid material. Figure 6 shows how unequal drag forces on the airfoils cause an angular acceleration on the rotor, which in turn achieves the necessary angular velocity for the lift-driven rotation to continue. Figure 7 gives examples of drag-start lift-driven VAWT airfoil profiles.

**[0036]** This “drag-start” concept is derived from the drag-driven VAWT operating principles, and if combined with lift-driven VAWT principles it will allow a self-starting combination of the two, as shown in Figure 5. As mentioned above, lift-driven turbines are more efficient than drag-driven ones. This invention will benefit lift-driven wind turbines by eliminating the need for starting mechanisms. They will perform more efficiently since no energy will be expended to start turning the rotor.

**[0037]** A combination of both aspects will yield an efficient wind turbine with very low manufacturing and operating costs which can safely be installed in urban settings.

**[0038]** This invention is very attractive to a wide variety of energy companies, especially with the current enthusiasm for energy technologies in the national and international marketplace. The functions discussed above will allow wind energy devices to be economically used in locations and applications that are currently unattractive with state-of-the-art wind



turbines, and will allow consumers to fulfill a portion of their own energy needs. The invention could be easily commercialized due to the expected low-cost manufacturing, improved efficiency, potential for smaller turbine sizes, low weight, easy installation, and overall simplicity.

**[0039]** Accordingly and with particular reference to Figure 1 and Figure 2, one aspect of the invention can be described as a horizontal axis wind turbine **100** in relation to a wind direction **102**. In keeping with the usual convention, the wind direction **102** shown in the figures points into the wind. The wind turbine **100** includes a support post **104**, a shaft **106**, and a plurality of turbine blades **108**. The support post **104** also defines a pivot axis **105**.

**[0040]** The shaft **106** has an upwind portion **110** and a downwind portion **112**. The upwind portion **110** is upwind from the downwind portion **112** relative to the wind direction **102**. Preferably, the shaft **106** is pivotally connected to the support post **104** at the upwind portion **110** of the shaft **106**. The shaft **106** also defines an axis of rotation **114**.

**[0041]** The plurality of turbine blades **108** extends radially from the downwind portion **112** of the shaft **106**. The turbine blades of the plurality of turbine blades **108** are equally spaced radially about the shaft **106**. The plurality of turbine blades **108** rotate about the axis of rotation **114**. Each turbine blade **108** has an inflated condition and a deflated condition. The plurality of turbine blades **108** defines a rotor plane **116** in the inflated condition.

**[0042]** Each turbine blade **108** has a flexible skin **118** and an internal skeleton **128**, preferably within (that is, substantially surrounded by) the flexible skin **118**. The flexible skin **118** includes a leading edge **120**, an upper surface **122**, and a lower surface **124**. The leading edge **120** has one or more openings **126**. The internal skeleton **128** supports the flexible skin **118**. The upper surface **122**, the lower surface **124**, and the internal skeleton **128** form a plurality of

inflation chambers **130**. In a version of the invention, the inflation chambers **130** are connected by cross ports **132** in the internal skeleton **128**. Each opening **126** in the leading edge **120** leads to one or more of the inflation chambers **130** for ram air inflation during operation. In the inflated condition, the plurality of inflation chambers **130** is filled with air and the flexible skin **118**, which is supported by the internal skeleton **128**, has a blade structure. In some embodiments, in the deflated condition the turbine blade **108** is collapsed and does not have a blade structure.

[0043] The pivotal connection between the shaft **106** and the support post **104** allows the plurality of turbine blades **108** to yaw about the pivot axis **105** such that the rotor plane **116** remain substantially perpendicular to the wind direction **102**.

[0044] With particular reference to Figure 3, another aspect of the invention can be described as a vertical axis wind turbine **200** in relation to a wind stream **202** having a wind speed. In keeping with the usual convention, the direction of the wind stream **202** shown in the figures points into the wind. The wind turbine **200** includes a support post **204** defining an axis of rotation **206** and an inflatable airfoil **208** rotatably connected to the support post **204**. The airfoil **208** rotates about the axis of rotation **206** at an angular velocity that has a tangential speed component. The airfoil **208** has a right half **210** and a left half **212**.

[0045] Each of the right half **210** and the left half **212** is semi-toroidal and has a toroidal axis **214**. The right half **210** and the left half **212** each has a leading edge **216**, a trailing edge **218**, a plurality of ribs **220**, and a flexible skin **222**.

[0046] The leading edge **216** has a leading edge wire **226**, which is preferably a rigid wire or a tube. The trailing edge **218** has an outer trailing edge wire **228** and an inner trailing edge wire

**230**, each of which is preferably a rigid wire or a tube. The inner trailing edge wire **230** is closer to the toroidal axis **214** than the outer trailing edge wire **228**.

[0047] The plurality of ribs **220** connects the leading edge **216** to the trailing edge **218**. Each rib **220** preferably has airfoil cross-section, meaning it has a cross-section similar to the profiles shown in Figure 5 and Figure 6, although other suitable airfoil profiles are also possible. In a version of the invention, the ribs **220** are flexible webbing.

[0048] The flexible skin **222** extends from the outer trailing edge wire **228** around the leading edge **216** to the inner trailing edge wire **230** and generally covers each of the plurality of ribs **220**, thereby forming a semi-toroidal airfoil profile. In a version of the invention, the flexible skin **222** does not extend directly from that outer trailing edge wire **228** to the inner trailing edge wire **230**, thereby leaving the trailing edge **218** open and forming an inflation cavity **232**.

[0049] The right half **210** and the left half **212** are symmetrical about and join at the support post **204**. The right half **210** is oriented such that the right half leading edge **216** is on a first side **234** of the wind turbine **200** and the right half trailing edge **218** is on an opposite second side **236** of the wind turbine **200**. The left half **212** is oriented such that the left half leading edge **216** is on the second side **236** of the wind turbine **200** and the left half trailing edge **218** is on the first side **234**. The right half leading edge **216** and the left half trailing edge **218** generally form a circular edge on the first side **234** of the wind turbine **200**, such as depicted in Figure 3. The left half leading edge **216** and the right half trailing edge **218** generally form a circular edge on the second side **236** of the wind turbine **200**, such as depicted in Figure 3.

[0050] During operation, the wind stream **202** forces air into the inflation cavity **232** thereby inflating the airfoil **208** and producing a drag force. The drag force causes the airfoil **208** to start rotating about the axis of rotation **206**.

[0051] The wind turbine **200** may also include a plurality of self-deploying drag vanes **224** connected to an outside surface **225** of the flexible skin **222**. The drag vanes **224** extend away from the flexible skin **222** when the wind speed is greater than the tangential speed component of the airfoil **208**. The drag vanes **224** retract against the flexible skin **222** when the tangential speed component of the airfoil **208** is greater than the wind speed. In a version of the invention, a trailing edge **218** is not open, and the airfoil **208** includes the drag vanes **224** as a way to drag start the airfoil's rotation.

[0052] With particular reference to Figure 4, in yet another aspect the invention can be described as a continuous response, vertical axis wind turbine **300** in relation to a wind stream **302** having a wind speed. In keeping with the usual convention, the direction of the wind stream **302** shown in the figures points into the wind. The wind turbine **300** has a support post **304** that defines an axis of rotation **306**. The wind turbine **300** also has an inflatable airfoil **308** rotatably connected to the support post **304** and rotating about the axis of rotation **306** at an angular velocity, which has a tangential speed component. The airfoil **308** preferably has helical blades **310**.

[0053] Preferably, each helical blade **310** has a helical twist of 180 degrees. Each helical blade includes a leading edge **312**, a first trailing edge **314**, a second trailing edge **316**, a flexible skin **318**, and a plurality of ribs **320**. In a version of the invention, the ribs **320**, or webbing, are flexible. The leading edge **312** forms a helix that is closer to the support post **304** than a helix formed by the first trailing edge **314** and a helix formed by the second trailing edge **316**. In a version of the invention, the helix formed by the first trailing edge **314** is equidistant from the support post **304** as the helix formed by the second trailing edge **316**.

[0054] The flexible skin **318** extends from the first trailing edge **314** to the leading edge **312** to form an upper airfoil surface **324**. The flexible skin **318** also extends from the leading edge **312** to the second trailing edge **316** and forms a lower airfoil surface **326**. Preferably, the flexible skin **318** does not extend directly from the first trailing edge **314** to the second trailing edge **316**, thereby leaving the trailing edge open.

[0055] The plurality of ribs **320** connects the leading edge **312** to the first trailing edge **314** and the second trailing edge **316**. Each rib **320** extends radially with respect to the support post **304** and is perpendicular to the helix formed by the first trailing edge **314** and this helix formed by the second trailing edge **316**. Preferably, each rib **320** has an airfoil cross-section. The plurality of ribs **320** and the flexible skin **318** define a plurality of inflation cavities **328**.

[0056] In an inflated condition of the helical blade **310**, the combination of the leading edge **312**, first trailing edge **314**, second trailing edge **316**, flexible skin **318**, and plurality of ribs **320** gives the helical blade **310** an airfoil is profile.

[0057] During operation, the wind stream **302** forces air into the plurality of inflation cavities **328**, thereby inflating the helical blade **310**, defining the inflated condition, and producing a drag force. The drag force causes the airfoil **308** to start rotating about the axis of rotation **306**.

[0058] In a version of the invention, the wind turbine **300** also includes a plurality of self deploying drag vanes **322** connected to the upper airfoil surface **324** and the lower airfoil surface **326**. The drag vanes **322** extend from the upper airfoil surface **324** and the lower airfoil surface **326** when the wind speed is greater than the tangential speed component of the airfoil **308**. The drag vanes **322** retract against the respective upper airfoil surface **324** and lower airfoil surface **326** when the tangential speed component of the airfoil **308** is greater than the wind speed.

**[0059]** While the present invention has been described with regards to particular embodiments, it is recognized that variations of the present invention may be devised without departing from the inventive concept.

#### INDUSTRIAL APPLICABILITY

**[0060]** This invention may be industrially applied to the development, manufacture, and use of wind turbines.

## CLAIMS

WHAT IS CLAIMED IS:

1. A horizontal axis wind turbine in relation to a wind direction, the wind turbine  
2 comprising:

(a) a support post further defining a pivot axis;

4 (b) a shaft having an upwind portion and a downwind portion, the upwind portion  
being upwind from the downwind portion relative to the wind direction, the shaft being  
6 pivotally connected to the support post at the upwind portion of the shaft, the shaft further  
defining an axis of rotation; and

8 (c) a plurality of turbine blades extending radially from the downwind portion of the  
shaft, the plurality of turbine blades being equally spaced radially about the shaft, the  
10 plurality of turbine blades rotating about the axis of rotation, where each turbine blade  
has an inflated condition and a deflated condition, the plurality of turbine blades defining  
12 a rotor plane in the inflated condition, and where each turbine blade comprises (i) a  
flexible skin, the flexible skin including a leading edge, an upper surface, and a lower  
14 surface, the leading edge having one or more openings, and (ii) an internal skeleton  
within the flexible skin, the internal skeleton supporting the flexible skin, where the  
16 upper surface, the lower surface, and the internal skeleton form a plurality of inflation  
chambers, the inflation chambers being connected by cross ports in the internal skeleton,  
18 each opening in the leading edge leading to one or more of the inflation chambers for ram  
air inflation during operation, where, in the inflated condition the plurality of inflation  
20 chambers are filled with air and the flexible skin, supported by the internal skeleton, has a

blade structure, where, in the deflated condition the turbine blade is collapsed and does  
22 not have the blade structure, and

where the pivotal connection between the shaft and the support post allows the plurality  
24 of turbine blades to yaw about the pivot axis such that rotor plane remains substantially  
perpendicular to the wind direction.

2. A horizontal axis wind turbine in relation to a wind direction, the wind turbine  
2 comprising:

- (a) a support post;
- 4 (b) a shaft defining an axis of rotation; and
- (c) a plurality of turbine blades extending radially from the shaft, the plurality of  
6 turbine blades being equally spaced radially about the shaft, the plurality of turbine  
blades rotating about the axis of rotation, where each turbine blade has an inflated  
8 condition and a deflated condition, the plurality of turbine blades defining a rotor plane in  
the inflated condition, and where each turbine blade comprises (i) a flexible skin, the  
10 flexible skin including a leading edge, an upper surface, and a lower surface, the upper  
surface and the lower surface forming an inflation chamber, the leading edge having one  
12 or more openings leading to the inflation chamber for ram air inflation during operation,  
and (ii) a skeleton supporting the flexible skin, where, in the inflated condition the  
14 inflation chamber is filled with air and the flexible skin, supported by the skeleton, has a  
blade structure, and where, in the deflated condition the turbine blade is collapsed and  
16 does not have the blade structure.



3. The wind turbine of claim 2, where shaft has an upwind portion and a downwind portion,  
2 the upwind portion being upwind from the downwind portion relative to the wind direction, and  
the plurality of turbine blades extend radially from the downwind portion of the shaft.

4. The wind turbine of claim 2, where the shaft is pivotally connected to the support post at  
2 the upwind portion of the shaft and the support post further defines a pivot axis, and where the  
pivotal connection between the shaft and the support post allows the plurality of turbine blades to  
4 yaw about the pivot axis such that rotor plane remains substantially perpendicular to the wind  
direction.

5. The wind turbine of claim 2, where the upper surface and the lower surface, along with  
2 the skeleton, form a plurality of inflation chambers.

6. The wind turbine of claim 2, where the skeleton is covered by the flexible skin.

7. A vertical axis wind turbine in relation to a wind stream having a wind speed, the wind  
2 turbine comprising a support post defining an axis of rotation and a inflatable airfoil rotatively  
connected to the support post and rotating about the axis of rotation at an angular velocity, the  
4 angular velocity having a tangential speed component, the airfoil comprising a right half and a  
left half, each of the right half and the left half being semi-toroidal and having a toroidal axis,  
6 each of the right half and the left half comprising:

(a) a leading edge comprising a rigid wire referred to here as the leading edge wire;

8 (b) a trailing edge comprising a pair of rigid wires referred to here as the outer  
trailing edge wire and the inner trailing edge wire, where the inner trailing edge wire is  
10 closer to the toroidal axis than the outer trailing edge wire;

(c) a plurality of ribs connecting the leading edge to the trailing edge, each rib having  
12 an airfoil cross-section; and

(d) a flexible skin extending from the outer trailing edge wire around the leading edge  
14 to the inner trailing edge wire and generally covering each of the plurality of ribs thereby  
forming a semi-toroidal airfoil profile, the flexible skin not extending directly from the  
16 outer trailing edge wire to the inner trailing edge wire, thereby leaving the trailing edge  
open and forming an inflation cavity;

18 where the right half and the left half are symmetrical about and join at the support post,  
the right half oriented such that the right half leading edge is on a first side of the wind turbine  
20 and the right half trailing edge is on an opposite second side of the wind turbine, the left half  
oriented such that the left half leading edge is on the second side of the wind turbine and the left  
22 half trailing edge is on the first side, where the right half leading edge and the left half trailing  
edge generally form a circular edge on the first side of the wind turbine, where the left half  
24 leading edge and the right half trailing edge generally form a circular edge on the second side of  
the wind turbine; and

26 where during operation the wind stream forces air into the inflation cavity thereby  
inflating the airfoil and producing a drag force, the drag force causing the airfoil to start rotating  
28 about the axis of rotation.

8. The wind turbine of claim 7, further comprising a plurality of self-deploying drag vanes  
2 connected to an outside surface of the flexible skin, the drag vanes extending away from the  
flexible skin when the wind speed is greater than the tangential speed component of the airfoil,  
4 the drag vanes retracting against the flexible skin when the tangential speed component of the  
airfoil is greater than the wind speed.

9. A vertical axis wind turbine in relation to a wind stream having a wind speed, the wind  
2 turbine comprising a support post defining an axis of rotation and a inflatable airfoil rotatively

connected to the support post and rotating about the axis of rotation at an angular velocity, the  
4 angular velocity having a tangential speed component, the airfoil comprising a right half and a  
left half, each of the right half and the left half being semi-toroidal and having a toroidal axis,  
6 each of the right half and the left half comprising:

- (a) a leading edge comprising a rigid wire referred to here as the leading edge wire;
- 8 (b) a trailing edge comprising a rigid wire referred to here as the trailing edge wire;
- (c) a plurality of ribs connecting the leading edge to the trailing edge, each rib having  
10 an airfoil cross-section;
- (d) a flexible skin extending from the trailing edge wire around the leading edge back  
12 to the trailing edge wire and generally covering each of the plurality of ribs thereby  
forming a semi-toroidal airfoil profile; and
- 14 (e) a plurality of self-deploying drag vanes connected to an outside surface of the  
flexible skin, the drag vanes extending away from the flexible skin when the wind speed  
16 is greater than the tangential speed component of the airfoil, the drag vanes retracting  
against the flexible skin when the tangential speed component of the airfoil is greater than  
18 the wind speed;

where the right half and the left half are symmetrical about and join at the support post,  
20 the right half oriented such that the right half leading edge is on a first side of the wind turbine  
and the right half trailing edge is on an opposite second side of the wind turbine, the left half  
22 oriented such that the left half leading edge is on the second side of the wind turbine and the left  
half trailing edge is on the first side, where the right half leading edge and the left half trailing  
24 edge generally form a circular edge on the first side of the wind turbine, where the left half

26 leading edge and the right half trailing edge generally form a circular edge on the second side of  
the wind turbine.

10. A continuous response, vertical axis wind turbine in relation to a wind stream having a  
2 wind speed, the wind turbine comprising a support post defining an axis of rotation; and an  
inflatable airfoil rotatively connected to the support post and rotating about the axis of rotation at  
4 an angular velocity, the angular velocity having a tangential speed component, the airfoil  
comprising a pair of helical blades symmetrical about the support post, each helical blade having  
6 a helical twist of 180 degrees, each helical blade comprising:

(a) a leading edge,

8 (b) a first trailing edge,

(c) a second trailing edge, where the leading edge forms a helix that is closer to the  
10 support post than a helix formed by the first trailing edge and a helix formed by the  
second trailing edge, and where the helix formed by the first trailing edge is equidistant  
12 from the support post as the helix formed by the second trailing edge,

(d) a flexible skin extending from the first trailing edge to the leading edge and  
14 forming an upper airfoil surface, the flexible skin also extending from the leading edge to  
the second trailing edge and forming a lower airfoil surface, the flexible skin not  
16 extending directly from the first trailing edge to the second trailing edge thereby leaving  
the trailing edge open, and

18 (e) a plurality of flexible ribs connecting the leading edge to the first trailing edge and  
the second trailing edge, each rib extending radially with respect to the support post and  
20 being perpendicular to the helix formed by the first trailing edge and the helix formed by

the second trailing edge, each rib having an airfoil cross-section, the plurality of ribs  
22 along with the flexible skin forming a plurality of inflation cavities;

where in an inflated condition of the helical blade, the combination of the leading edge,  
24 first trailing edge, second trailing edge, flexible skin, and plurality of ribs gives the helical blade  
an airfoil profile; and

26 where during operation the wind stream forces air into the plurality of inflation cavities  
thereby inflating the helical blade, defining the inflated condition, and producing a drag force,  
28 the drag force causing the airfoil to start rotating about the axis of rotation.

11. The wind turbine of claim 10, further comprising a plurality of self-deploying drag vanes  
2 connected to the upper airfoil surface and the lower airfoil surface, the drag vanes extending  
from the upper airfoil surface and the lower airfoil surface when the wind speed is greater than  
4 the tangential speed component of the airfoil, the drag vanes retracting against the respective  
upper airfoil surface and lower airfoil surface when the tangential speed component of the airfoil  
6 is greater than the wind speed.

12. A continuous response, vertical axis wind turbine in relation to a wind stream having a  
2 wind speed, the wind turbine comprising a support post defining an axis of rotation; and an  
inflatable airfoil rotatively connected to the support post and rotating about the axis of rotation at  
4 an angular velocity, the angular velocity having a tangential speed component, the airfoil  
comprising at least one helical blade about the support post, the helical blade comprising:

- 6 (a) a leading edge,  
(b) a first trailing edge,

8 (c) a second trailing edge, where the leading edge forms a helix that is closer to the  
support post than a helix formed by the first trailing edge and a helix formed by the  
10 second trailing edge,

(d) a flexible skin extending from the first trailing edge to the leading edge and  
12 forming an upper airfoil surface, the flexible skin also extending from the leading edge to  
the second trailing edge and forming a lower airfoil surface, the flexible skin not  
14 extending directly from the first trailing edge to the second trailing edge thereby leaving  
the trailing edge open, and

16 (e) a plurality of flexible ribs connecting the leading edge to the first trailing edge and  
the second trailing edge, each rib extending radially with respect to the support post and  
18 being perpendicular to the helix formed by the first trailing edge and the helix formed by  
the second trailing edge, each rib having an airfoil cross-section, the plurality of ribs  
20 along with the flexible skin forming a plurality of inflation cavities;

where in an inflated condition of the helical blade, the combination of the leading edge,  
22 first trailing edge, second trailing edge, flexible skin, and plurality of ribs gives the helical blade  
an airfoil profile; and

24 where during operation the wind stream forces air into the plurality of inflation cavities  
thereby inflating the helical blade, defining the inflated condition, and producing a drag force,  
26 the drag force causing the airfoil to start rotating about the axis of rotation.

13. The wind turbine of claim 12, further comprising a plurality of self-deploying drag vanes  
2 connected to the upper airfoil surface and the lower airfoil surface, the drag vanes extending  
from the upper airfoil surface and the lower airfoil surface when the wind speed is greater than  
4 the tangential speed component of the airfoil, the drag vanes retracting against the respective

upper airfoil surface and lower airfoil surface when the tangential speed component of the airfoil  
6 is greater than the wind speed.

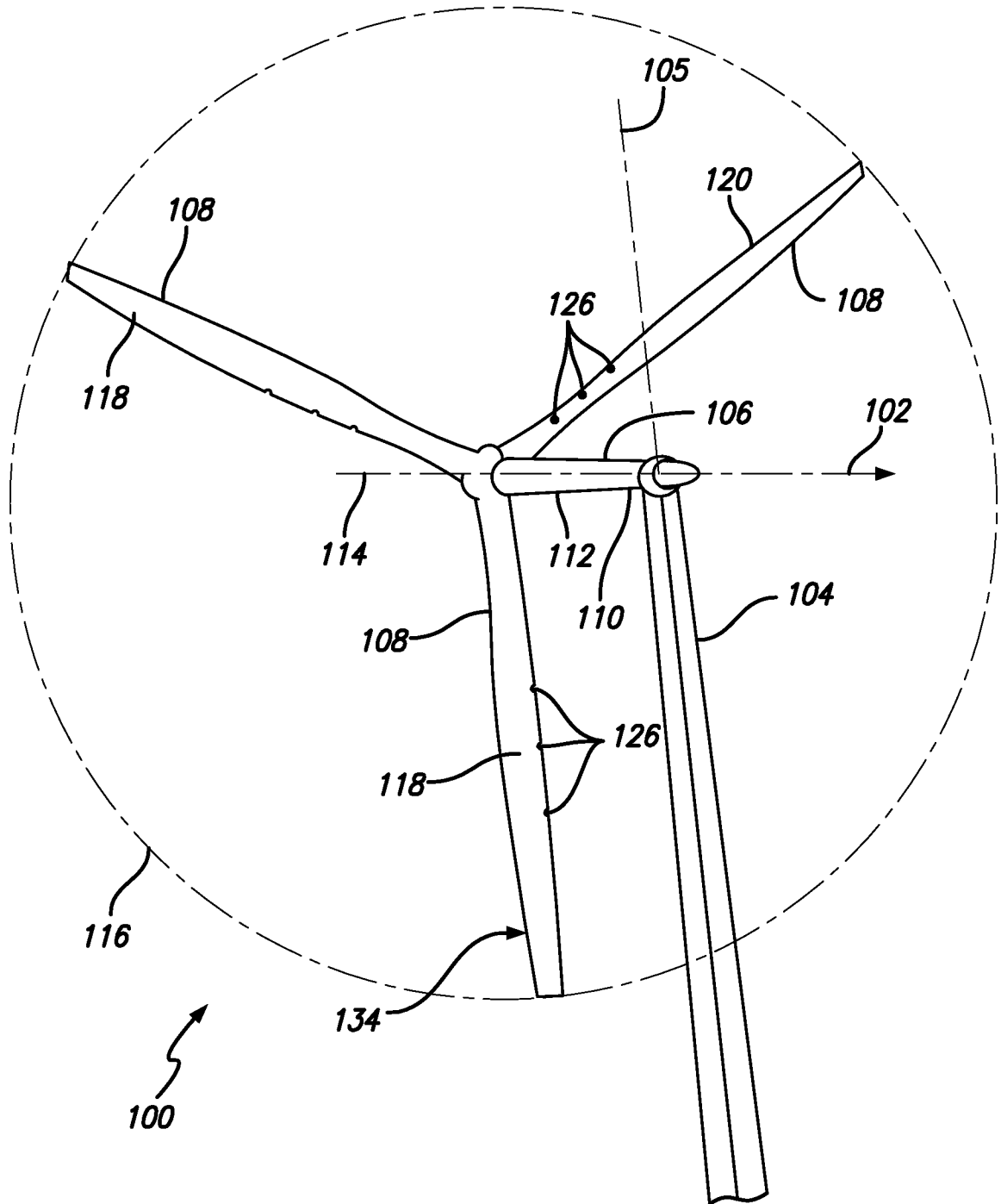

FIG. 1



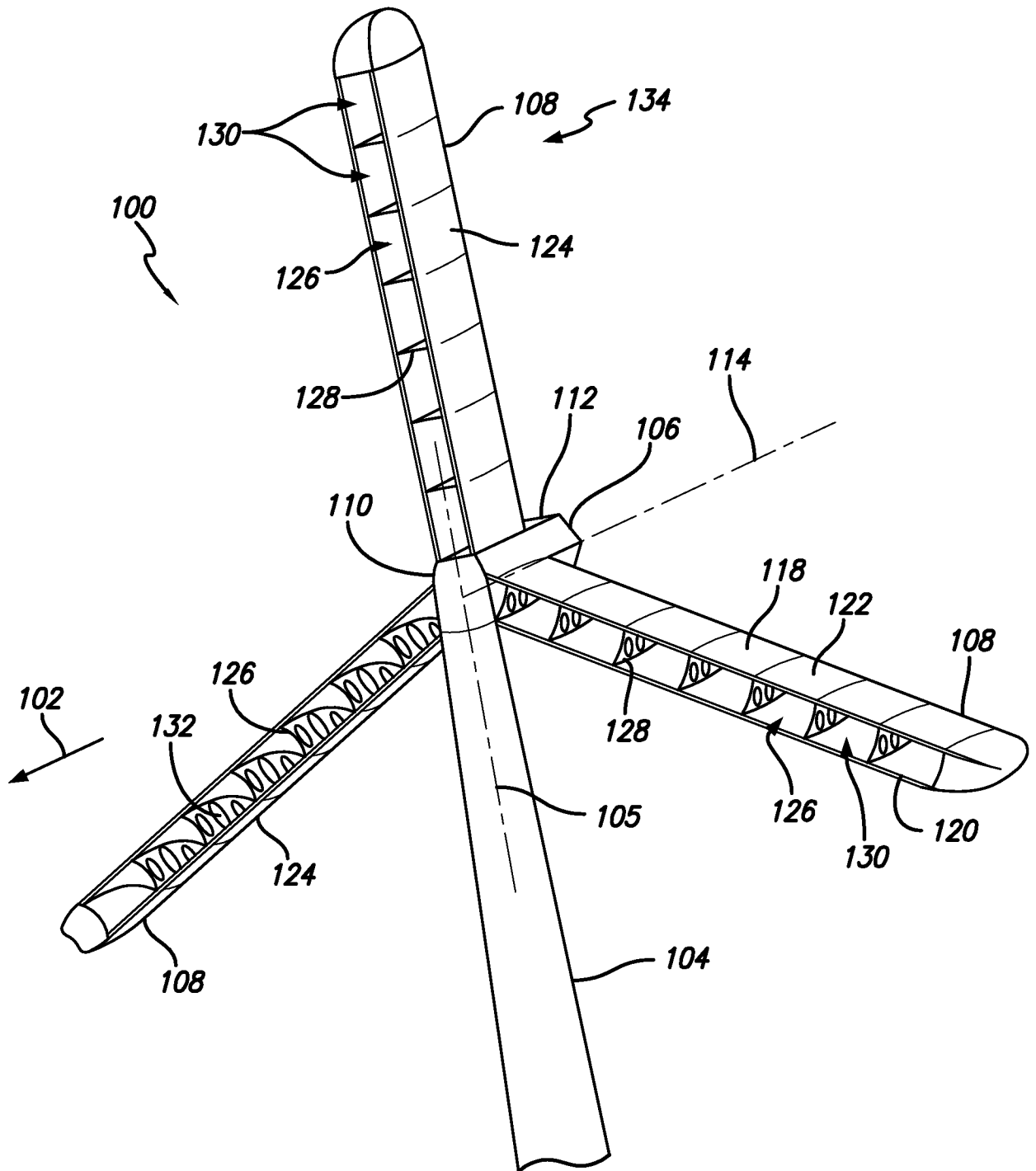

FIG. 2

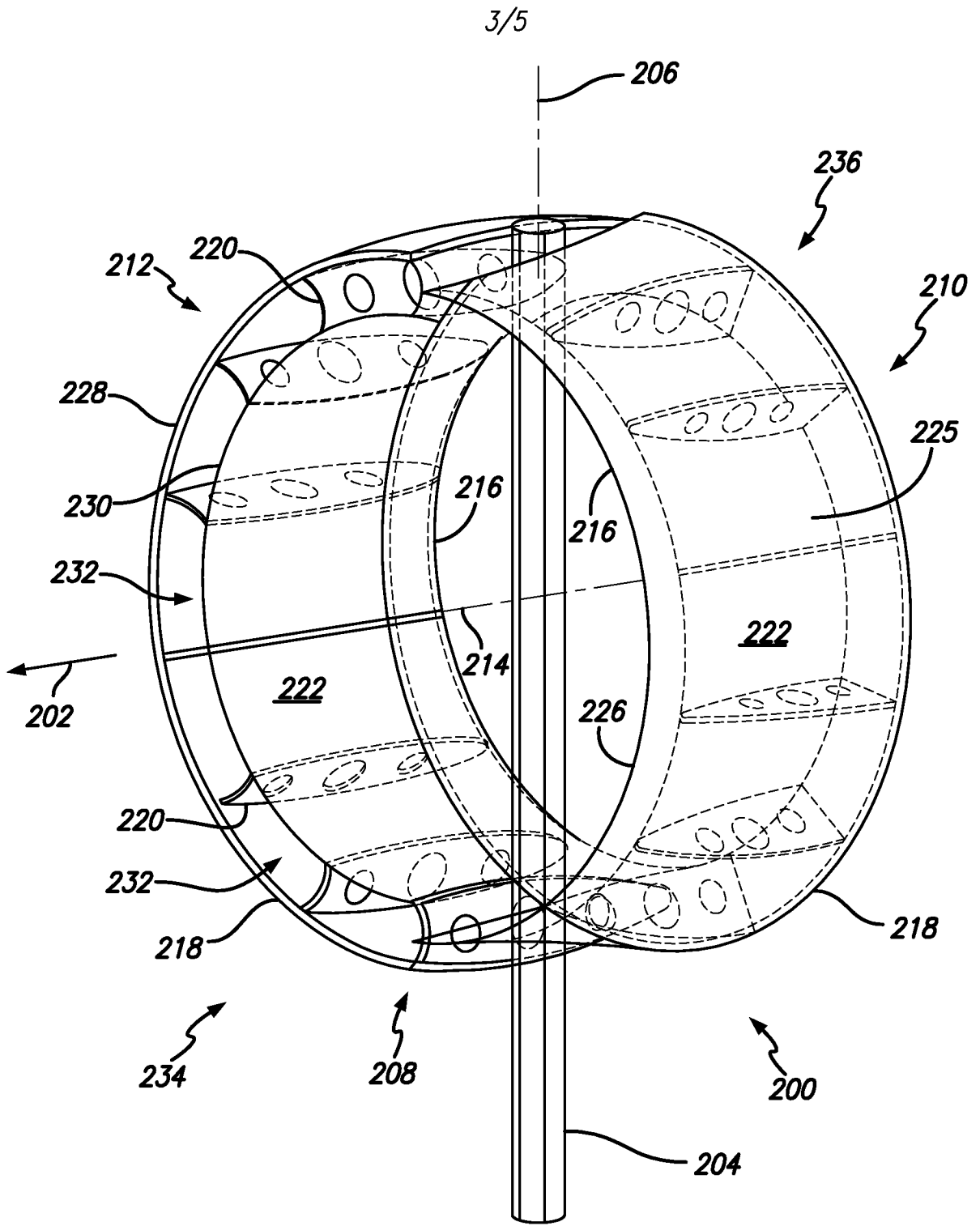

FIG. 3

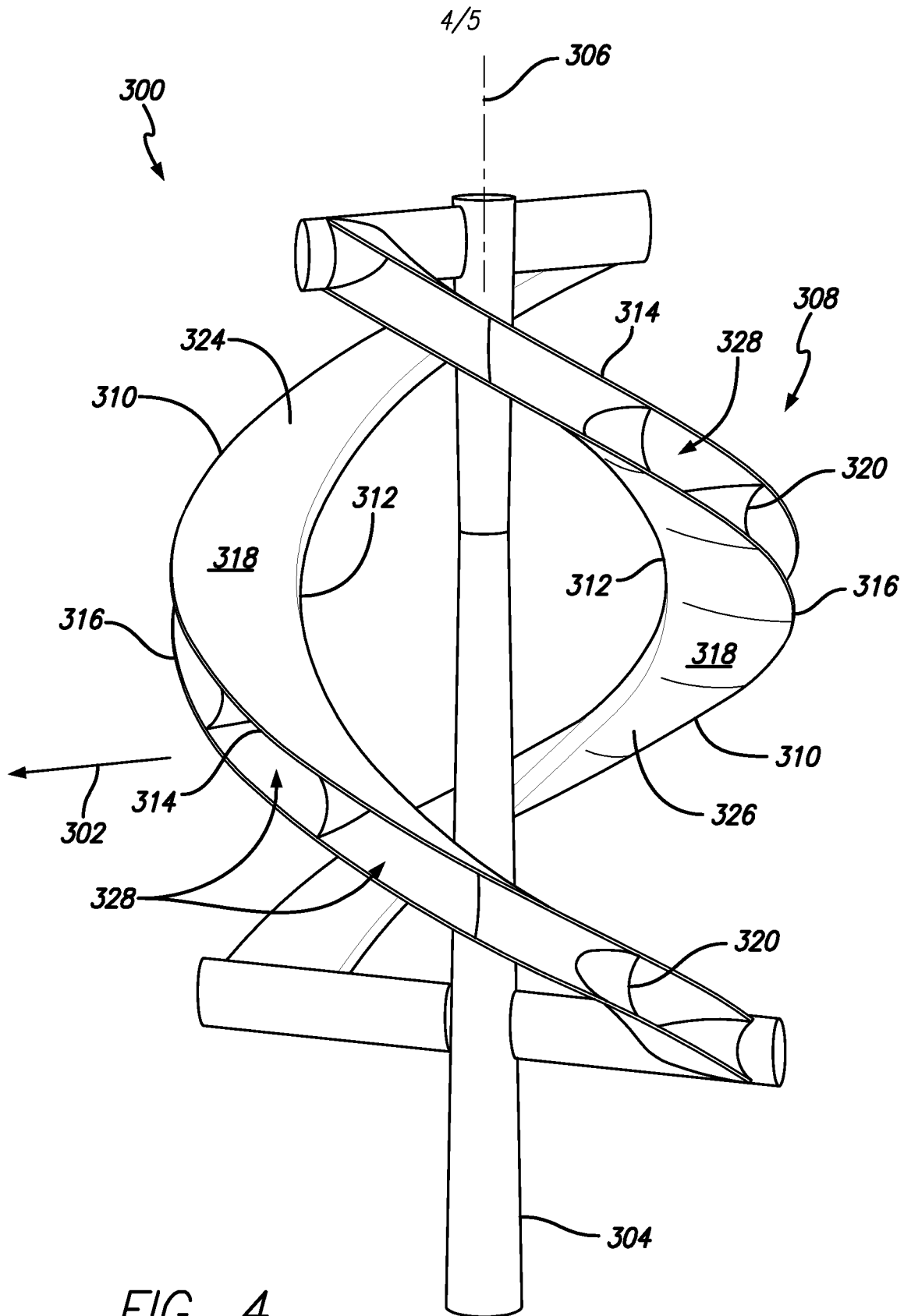

FIG. 4

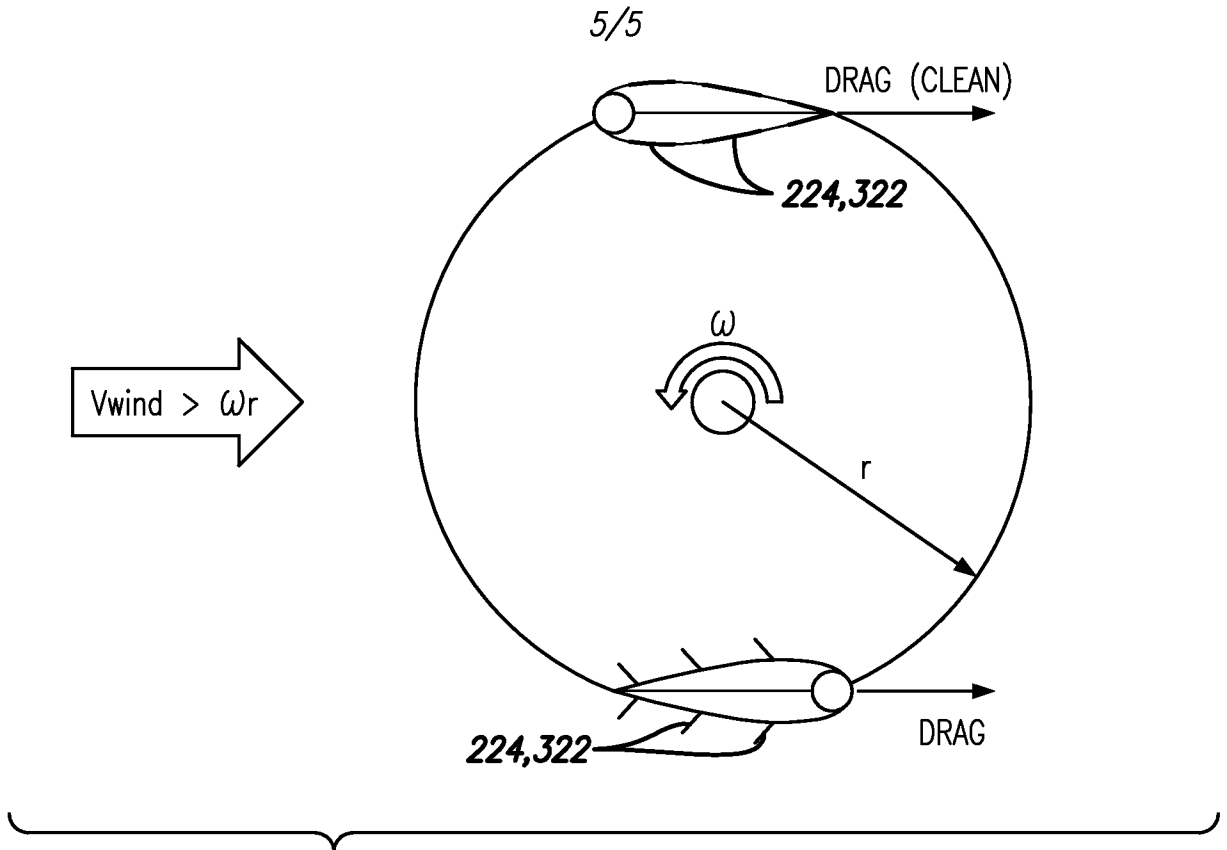

FIG. 5

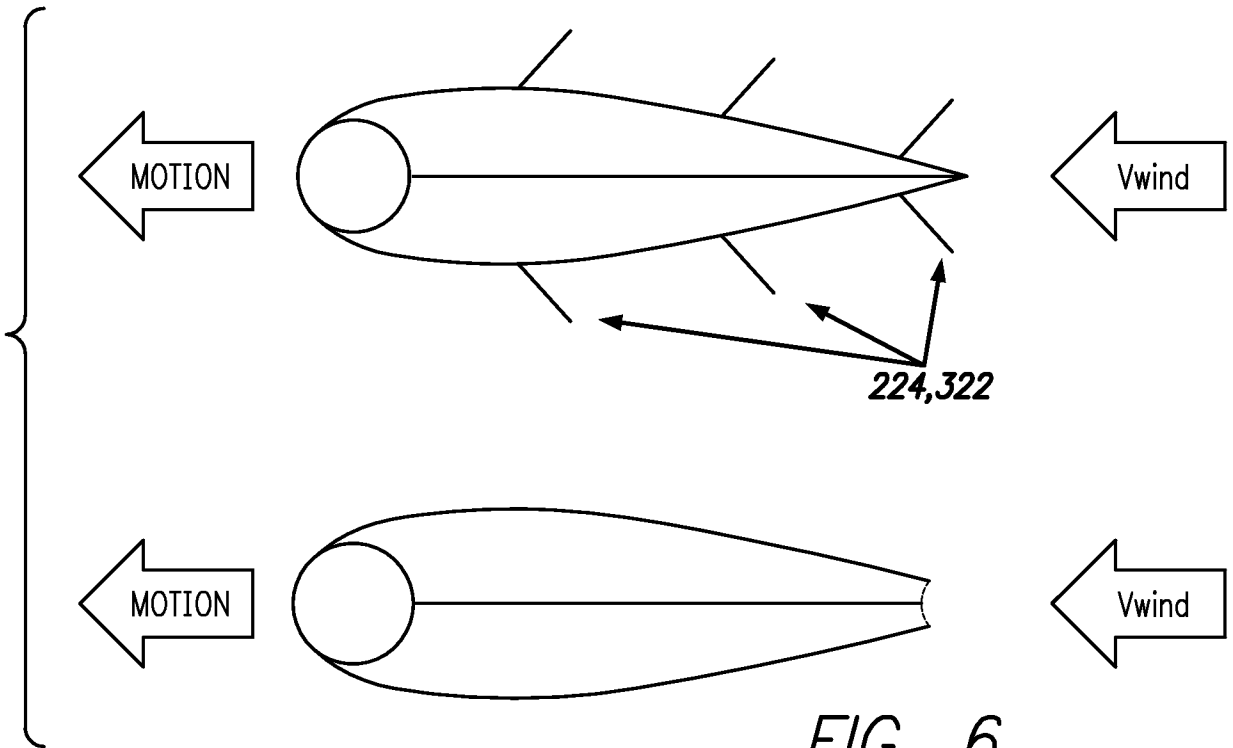

FIG. 6