

Aug. 20, 1935.

F. O. ANDEREGG

2,011,557

WINDOW STRUCTURE

Filed Dec. 7, 1933

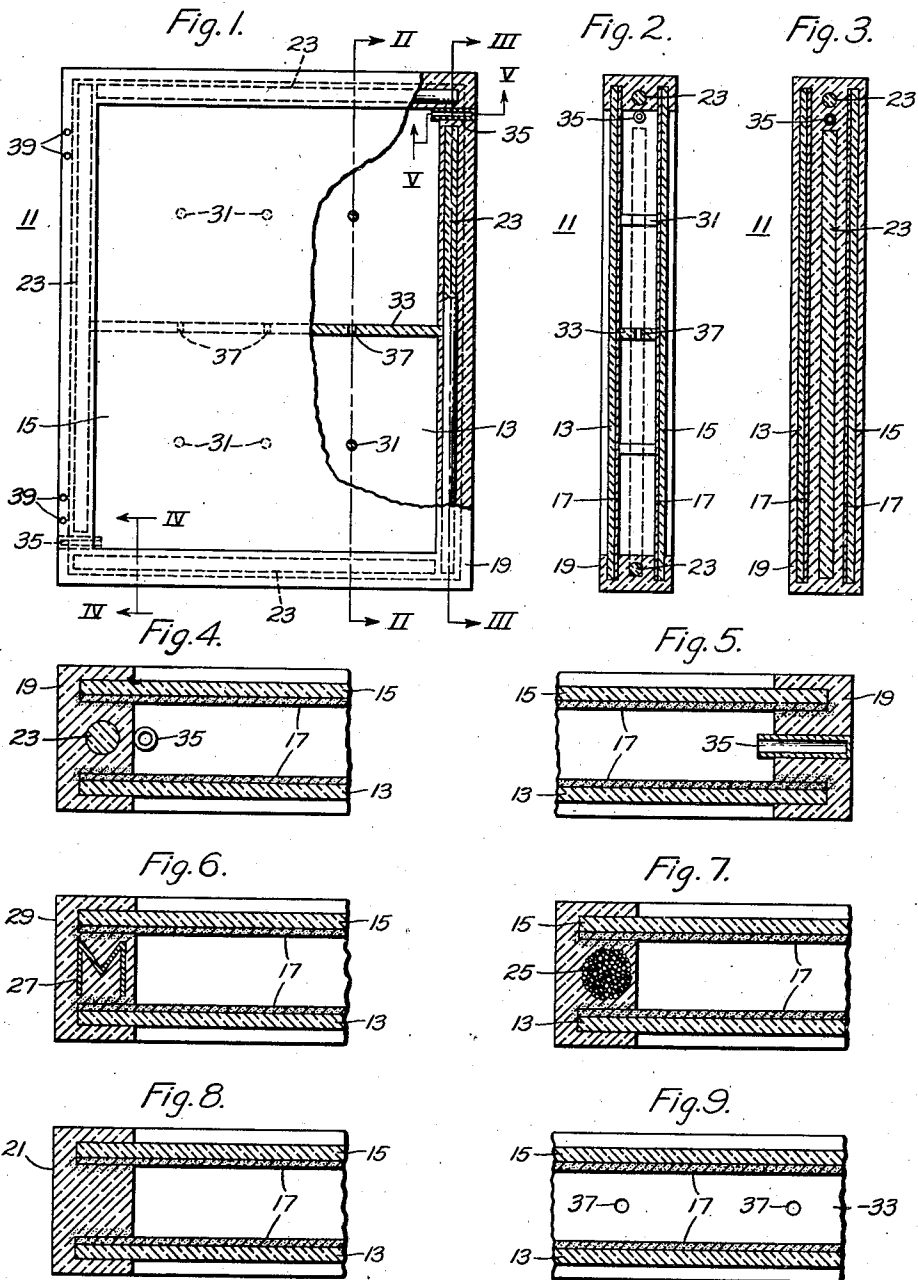

WITNESS

Wm. C. Groome

INVENTOR

Frederick O. Anderegg.

BY

H. M. Bichel

ATTORNEY

UNITED STATES PATENT OFFICE

2,011,557

WINDOW STRUCTURE

Frederick O. Anderegg, Forest Hills Borough, Pa.

Application December 7, 1933, Serial No. 701,354

17 Claims. (Cl. 20—56.5)

My invention relates to windows and particularly to double wall windows. An object of my invention is to provide a double wall anti-fogging window structure embodying a novel frame structure.

Another object of my invention is to provide a window structure that shall have a relatively high heat-insulating characteristic.

Another object of my invention is to provide a double wall window structure that shall be so constructed as to maintain its original non-condensing characteristic indefinitely and prevent crystalline growth on the inclosed surfaces.

Another object of my invention is to provide a relatively simple and inexpensive assembly for a double wall window structure that shall be easily and quickly installed.

Another object of my invention is to provide a double wall window structure that shall be substantially self-contained and be provided with means for attaching thereto the mounting or supporting fixtures.

Other objects of my invention will either be apparent from the description of a structure embodying my invention or will be pointed out during the description thereof.

In practicing my invention I provide a pair of spaced panes of glass, each pane having a relatively thin layer of a transparent resin on the inner surface and a peripheral frame and gasket including a transparent resin, around and between the edges of the panes of glass, the gasket including a stiffener of any one of a number of different materials. I may also enclose a gas having a molecular weight greater than air, between the panes of glass and also one or more spacers intermediate the edges of the panes to prevent collapse thereof under extreme changes of atmospheric pressure.

Figure 1 of the drawing illustrates, in front view, a window structure embodying my invention, a part thereof being shown in section,

Fig. 2 is a view, in section therethrough, taken on the line II—II of Fig. 1,

Fig. 3 is a view, in section therethrough, taken on the line III—III of Fig. 1,

Fig. 4 is a fragmentary sectional view, taken on the line IV—IV of Fig. 1,

Fig. 5 is a fragmentary sectional view taken on the line V—V of Fig. 1,

Fig. 6 is a fragmentary sectional view, similar to Fig. 4, showing a modified form of gasket spacer,

Fig. 7 is a fragmentary sectional view, similar

to Fig. 4, showing another modification of a gasket spacer,

Fig. 8 is a fragmentary sectional view, similar to Fig. 4, showing still another modification of a spacer gasket, and,

Fig. 9 is a fragmentary view, in central section.

Referring to Fig. 1 of the drawing, I have there illustrated a double wall structure 11, which comprises two panes of glass 13 and 15, which will usually, but not necessarily, be coextensive and which may be of any kind of glass used for windows.

One surface of each pane of glass is coated, as by dipping, spraying, or any other method effective for the purpose, with a relatively thin layer 17 of a resin solution which is transparent, which adheres tightly to the glass, and which remains so during its entire life in the device.

There are a number of resin solutions which I may use and I may mention glyptal resins, glycerol-phthalate modified by a drying oil such as tung oil, and particularly a solution of vinyl acetate or a similar vinylite, or in fact any similar resin solution which is transparent and which may or may not be thermo-plastic. The vinyl acetate or similar resin is mixed with a volatile solvent, such as any of the esters, for example ethyl acetate. I may also add thereto a plasticizer such as dibutyl phthalate, with the object of obtaining a transparent and substantially unchanging solution, which will readily adhere tightly to the surface of a pane of glass and which will prevent fogging and will not react with acids in the air to produce a bloom or efflorescence on the surface of the coating, which is not only unsightly but would also tend to reduce the transparency of the window. Before applying such coating the surface of the glass should be thoroughly cleaned, and the coating should be so applied as to be of uniform thickness and be evenly distributed.

In order to maintain this coating in its original condition it is necessary that it be sealed in and to this effect I provide a peripheral frame gasket and spacer member 19. This member may take any one of several forms, the simplest of which is shown in Fig. 8 where I have shown a frame and spacer 21 which may be made of a resin of the same kind used for making the spraying solution for the coating. This frame and spacer may be made of vinyl acetate which may be compounded with a plasticizer such as dibutyl phthalate or other resins, such as some of the glyptals. I may also use nitrocellulose in the strip to increase the stiffness of the frame and

gasket. This spacing frame may for instance be made up of a number of suitable pieces, either of straight or of L-shape and applied to the panes of glass and located in proper operative position thereon immediately after the coating on each sheet or pane of glass has been caused to adhere by being subjected to heat. It is also within the scope of my invention to assemble the two coated panes of glass with the spacer frame gasket in proper operative positions relatively to each other and subject the whole assembly to the proper degree of heat to cause the frame and coatings to harden and adhere to each other and to the surface of the pane of glass, whereby the latter is protected from etching action and crystal growth. The two coated panes of glass may be clamped together during the heating operation with sufficient pressure to cause the frame and gasket to adhere to the coatings and to form therewith a flat-box-like airtight member located between the two panes of glass and to hold them in spaced position a small distance apart, the outer edge portion of the frame extending beyond the edges of the glass and also enclosing the same, as shown in the drawing.

I may also use a glass rod 23 embedded in the gasket 19 as shown in Figs. 1 to 3 of the drawing, and as shown also on a slightly enlarged scale in Fig. 4 thereof. Fig. 3 shows a longitudinal section through one frame and gasket located adjacent one edge of the structure 11.

Referring to Fig. 7 of the drawing I have there shown a stiffener and spacer 25 which may comprise a bundle of relatively thin rods or threads of glass. I may also use a twisted cord or rope of artificial silk as a stiffener.

Referring to Fig. 6 of the drawing I have there shown a metal insert 27 in a frame gasket 29 of resin, and while I have shown a folded strip of metal, such as aluminum, I do not desire to be limited to any one form of folded metal strip or to one kind of metal. The main consideration is that the gasket shall cooperate with the layers of resin on the panes of glass to form therewith an air-tight box-like member, whose characteristics will not change with age.

A double wall structure of this kind will be subjected to relatively large variations of pressure on the outside of the panes of glass if used, for instance, in a Pullman car window, this difference of pressure being on the order of four pounds per square inch when the car in which the window is located travels from sea level to the highest altitude reached by railroad trains. It is obvious that the size of the panes of glass which can be used without an internal spacer is quite limited and to enable me to use larger panes of glass I provide, as shown in Fig. 1 of the drawing, a plurality of spacers 31 located between the coated panes of glass. These spacers may be in the form of short lengths of glass rods cut to the proper size or glass buttons, and any desired number of such posts or buttons may be used and distributed over the area of the window.

I may use one or more strips of glass or other transparent material extending laterally of the structure, such as is shown at 33 in Figs. 1, 2 and 9. Such strips of glass or equivalent material would prevent convection currents of air in the space between the panes of glass or at least reduce the vertical height of the space in which such convection currents of air can flow.

Most of the heat which flows transversely

across the structure comprising the two spaced panes of glass is by conduction and I provide suitable means to reduce such conductions. I may displace the air originally included between the panes of glass and in the air-tight box-like member by a fluid, preferably gaseous, which is transparent and which has a high molecular weight. I may use carbon dioxide for the gaseous filling, and in order to exhaust the air and introduce the gas of heavy molecular weight I may provide two small tubes 35 at opposite corners or points of the assembly, shown generally in Fig. 1 of the drawing and shown on an enlarged scale in Figs. 4 and 5 of the drawing. These tubes may, for instance, extend through the frame gasket 19 and be open initially at both ends. After the air in the space between the panes of glass has been displaced by the gas of heavy molecular weight the outer ends of the two tubes 35 may be sealed off flush with the 20 outer edge of the structure.

I may also use a fluorchloro compound of carbon or of phosphorus or mixtures of such and similar gases, having a boiling point less than -20° F., compounds which are transparent and which have a molecular weight greater than air (which has a molecular weight of 29) their molecular weight being 50 or even more. The use of a gas having a molecular weight greater than air tends to reduce the conduction of heat through the space between the spaced panes of glass, such reduction being in substantially direct proportion to the increased molecular weight.

I prefer to introduce the filler gas at an elevated temperature, say on the order of 120° F. or more, and to seal at subatmospheric pressure on the order of five to twelve pounds per square inch absolute. This may be done in any well known manner and will ensure that a positive pressure will never develop within the structure because of change in barometric pressure or rise in temperature. Small openings 37 may be provided in the strip 33 to permit the above described process to be carried out.

The gasket surrounding the edges of the pair of panes of glass extends therefrom a distance sufficient to provide a relatively strong frame which retains its mechanical strength under all ordinary conditions of operation and of service. Openings 39 may be provided in the frame to permit of securing thereto a mounting or supporting device, in the nature of a hinge structure or a lock or catch.

The window structure embodying my invention thus provides a relatively simple and easily manufactured and assembled double-pane anti-fogging window structure that embodies not only means for assuring that its original degree of transparency will continue throughout its use but includes also means for reducing the transfer of heat therethrough by means which does not impair its transparency. The structure can be handled as a unit after it has once been assembled and may be made relatively thin in its lateral dimension, that is the space between the two panes of glass may be on the order of $\frac{1}{4}$ inch or less.

While I have illustrated and described several forms of my invention now preferred by me, I do not wish to be restricted thereto but desire that all equivalents covered by the appended claims shall be included therein.

I claim as my invention:—

1. A unitary anti-fogging window structure including two spaced parallel extending panes of

glass, anti-fogging coatings adherent to and supported by the inner surfaces of the respective panes of glass and a frame extending peripherally of the panes of glass and integrally united with the coatings, said coatings and frame comprising a resin.

2. A window structure including a pair of spaced parallel-extending panes of glass, and an air-tight flat-box-like member of a transparent resin located between the panes and having its flat sides adhering tightly to the inner surfaces of the respective panes of glass.

3. A window structure comprising a pair of spaced panes of glass, relatively thin layers of a transparent resin one on each inner surface of each pane of glass and a reinforced gasket of a transparent resin at and between the edges of the panes of glass.

4. A window structure comprising a pair of panes of glass, a relatively thin layer of a transparent resin on the inner surface of each pane of glass, said layers being independent of each other and a spacing gasket at and between the edges of the panes of glass, said gasket including a core of solid material and a surrounding body of transparent resin.

5. A window structure comprising a pair of spaced parallel-extending panes of glass and an air-tight flat-box-like member of a transparent resin located between the panes of glass, having its flat sides adhering to the inner surfaces of the respective panes of glass and including a transparent spacer between the flat sides of the box-like member.

6. A device as set forth in claim 5 in which the gasket includes a stiffener extending longitudinally of the gasket.

7. A window structure comprising a pair of spaced substantially coextensive panes of glass, a relatively thin layer of transparent vinyl resin on the inner surface of the respective panes of glass and a spacing strip of vinyl resin at, between and around the edges of the panes of glass.

8. A structure as set forth in claim 7 in which the material of the spacing strip has chemically mixed therewith a stiffening material.

9. A structure as set forth in claim 7 in which the spacing strip includes a transparent refractory core.

10. A window structure comprising a pair of spaced coextensive panes of glass, an air-tight flat-box-like member of a transparent resin located between the panes of glass and having its larger sides adhering to the inner surface of the respective panes of glass and transparent gaseous means at sub-atmospheric pressure within the box-like member to reduce the speed of convection currents of air therewithin and to reduce the transfer of heat therethrough.

11. A window structure comprising a pair of

spaced parallel-extending panes of glass, relatively thin layers of a transparent resin on the inner surfaces of the respective panes of glass, said layers being spaced apart, a peripheral gasket of resin at and between the edges of the panes of glass and a heavier-than-air gas between the panes of glass to reduce the heat transfer therebetween.

12. A window structure comprising a pair of co-extensive parallel panes of glass, a relatively thin layer of a transparent resin adhering to the inner surface of the respective panes of glass, said layers being spaced apart, a peripheral gasket of a transparent resin at and between the panes of glass to space them apart and a transparent gaseous fluid having a boiling point of less than -20° F. between the panes of glass.

13. A window structure comprising a pair of spaced panes of glass, a thin layer of a transparent resin on the inner surfaces of the respective panes of glass, a transparent peripheral gasket having an air tight union with the two layers of resin, and a gaseous filling between the panes of glass having a pressure between seven and twelve pounds per square inch absolute.

14. A structure as set forth in claim 12 in which the gaseous fluid is at sub-atmospheric pressure.

15. A window structure comprising a pair of spaced parallel-extending panes of glass, a unitary air-tight flat-box-like member of a transparent vinyl resin located between the panes of glass and having its flat sides tightly adherent to the inner surfaces of the respective panes of glass and a heavier-than-air gaseous fluid within the flat-box-like member having a boiling point of less than -20° F., a molecular weight of more than 30 and a pressure of between seven and twelve pounds per square inch absolute.

16. A window structure comprising a pair of spaced co-extensive panes of glass, air-tight flat-box-like means formed of a transparent medium located between the panes of glass and having its larger sides adhering to the inner surfaces of the respective panes of glass, said medium at all conditions of the outer atmosphere being transparent, of solid status, adherent to glass, and a heavier-than-air gas confined within said air-tight flat-box-like means.

17. A window structure comprising a pair of spaced co-extensive panes of glass, air-tight flat-box-like means formed of a transparent medium located between the panes of glass and having its larger sides adhering to the inner surfaces of the respective panes of glass, said medium at all conditions of the outer atmosphere being transparent, of solid status, adherent to glass, and a heavier-than-air gas at sub-atmospheric pressure confined within said air-tight flat-box-like means.

FREDERICK O. ANDEREGG.