



US00D821441S

(12) **United States Design Patent**
Wilberding et al.

(10) **Patent No.:** **US D821,441 S**

(45) **Date of Patent:** **** Jun. 26, 2018**

(54) **DISPLAY SCREEN OR PORTION THEREOF WITH ANIMATED GRAPHICAL USER INTERFACE ELEMENTS INCORPORATING OVERLAPPING CIRCLES**

Jan. 31, 2018. Available online at URL: <http://stlandau.com/2015/01/28/stories-sell-content-strategy-adventure-brands-presentation/>.*

Baird, Ally. "CSS Loading." freefrontend.com, posted as part of "71 CSS Loaders" by Stepura, Vladimir, Sep. 14, 2017. Available May 28, 2016. Accessed Feb. 1, 2018. Available online at URL: <http://freefrontend.com/css-loaders/>.*

(71) Applicant: **Sonos, Inc.**, Santa Barbara, CA (US)

Primary Examiner — Cathron C Brooks

Assistant Examiner — Christian P. McLean

(72) Inventors: **Dayn Wilberding**, Santa Barbara, CA (US); **Sein Woo**, Santa Barbara, CA (US)

(74) *Attorney, Agent, or Firm* — KPPB LLP

(73) Assignee: **Sonos, Inc.**, Santa Barbara, CA (US)

(57) **CLAIM**

(**) Term: **15 Years**

The ornamental design for a display screen or portion thereof with animated graphical user interface elements incorporating overlapping circles, as shown and described.

(21) Appl. No.: **29/632,272**

DESCRIPTION

(22) Filed: **Jan. 5, 2018**

Related U.S. Application Data

The file of this patent contains at least one drawing executed in color. Copies of this patent with color drawings will be provided by the Office upon request and payment of the necessary fee.

(63) Continuation of application No. 29/571,976, filed on Jul. 22, 2016, now Pat. No. Des. 810,124.

FIG. 1 is a front elevational view of a first state for a first embodiment of a display screen or portion thereof with animated graphical user interface elements incorporating overlapping circles;

(51) **LOC (11) Cl.** **14-04**

(52) **U.S. Cl.** **D14/488; D14/490**

FIG. 2 is a front elevational view of a second state for the first embodiment of the display screen or portion thereof with animated graphical user interface elements incorporating overlapping circles;

(58) **Field of Classification Search**
USPC D14/485-495; 345/1.1, 1.2, 2.1-2.3, 3.1, 345/902; 715/763, 810, 836, 837, 846, 715/847, 977

(Continued)

FIG. 3 is a front elevational view of a third state for the first embodiment of the display screen or portion thereof with animated graphical user interface elements incorporating overlapping circles;

(56) **References Cited**

U.S. PATENT DOCUMENTS

FIG. 4 is a front elevational view of a fourth state for the first embodiment of the display screen or portion thereof with animated graphical user interface elements incorporating overlapping circles;

D684,190 S 6/2013 Ridl et al.
D691,629 S * 10/2013 Matas D14/488
(Continued)

FIG. 5 is a front elevational view of a fifth state for the first embodiment of the display screen or portion thereof with animated graphical user interface elements incorporating overlapping circles;

OTHER PUBLICATIONS

Landau, Stephen. "Stories that Sell: Content Strategy for Adventure Brands—The Presentation." stlandau.com. Jan. 28, 2015. Accessed

(Continued)

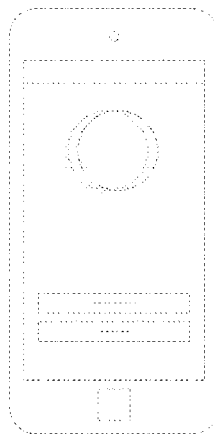
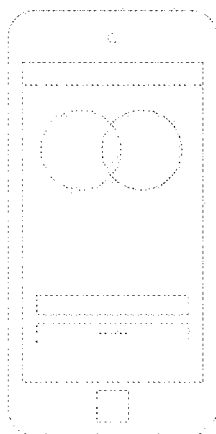

FIG. 6 is a front elevational view of a sixth state for the first embodiment of the display screen or portion thereof with animated graphical user interface elements incorporating overlapping circles;

FIG. 7 is a front elevational view of a seventh state for the first embodiment of the display screen or portion thereof with animated graphical user interface elements incorporating overlapping circles;

FIG. 8 is a front elevational view of a first state for a second embodiment of a display screen or portion thereof with animated graphical user interface elements incorporating overlapping circles;

FIG. 9 is a front elevational view of a second state for the second embodiment of the display screen or portion thereof with animated graphical user interface elements incorporating overlapping circles;

FIG. 10 is a front elevational view of a third state for the second embodiment of the display screen or portion thereof with animated graphical user interface elements incorporating overlapping circles;

FIG. 11 is a front elevational view of a fourth state for the second embodiment of the display screen or portion thereof with animated graphical user interface elements incorporating overlapping circles;

FIG. 12 is a front elevational view of a fifth state for the second embodiment of the display screen or portion thereof with animated graphical user interface elements incorporating overlapping circles;

FIG. 13 is a front elevational view of a sixth state for the second embodiment of the display screen or portion thereof with animated graphical user interface elements incorporating overlapping circles; and,

FIG. 14 is a front elevational view of a seventh state for the second embodiment of the display screen or portion thereof with animated graphical user interface elements incorporating overlapping circles.

The broken line portions of the display device and graphical user interface forms no part of the claimed design.

The subject matter in this patent includes a process or period in which an image changes into another image. The appearance of the animated image transitions sequentially between the images shown in FIGS. 1 through 7 and FIGS. 8 through 14.

The process or period in which one image transitions to another forms no part of the claimed design.

**1 Claim, 14 Drawing Sheets
(7 of 14 Drawing Sheet(s) Filed in Color)**

(58) **Field of Classification Search**

CPC G06F 3/048; G06F 3/0481; G06F 3/04812; G06F 3/04817; G06F 3/0482; G06F 3/0483; G06F 3/0484; G06F 3/04847; G06F 3/0485; G06F 3/04855; G06F 3/04886; G06Q 30/00; H03J 1/00; H03J 1/0008; H03J 1/0016; H03J 1/0025; H04N 5/00; H04N 5/08; H04N 5/14; H04N 5/222; H04N 5/225; H04N 5/232; H04N 5/445; H04N 5/44543; H04N 5/45; H04N 2005/44517; H04N 2005/44521; H04N 2005/44526; H04N 2005/4453; H04N 2005/44534; H04N 2005/44539; H04N 2005/44547; H04N 2005/44556; H04N 2005/4456; H04N 2005/44565; H04N 2005/44569; H04N 2005/44573; H04N 21/00; H04N 21/234; H04N 21/431; H04N 21/4312; H04N 21/4314; H04N 21/4316

See application file for complete search history.

(56)

References Cited

U.S. PATENT DOCUMENTS

D758,422	S	6/2016	Zhao	
D759,061	S	6/2016	Sahoo et al.	
D759,682	S *	6/2016	Myung	D14/485
D760,250	S *	6/2016	Myung	D14/485
D763,871	S *	8/2016	Yang	D14/485
D765,097	S *	8/2016	Harvell	D14/485
D766,282	S *	9/2016	Kaplan	D14/486
D767,629	S *	9/2016	Gupta	D14/492
D772,249	S	11/2016	Choi et al.	
D778,308	S *	2/2017	Wang	D14/486
D780,781	S *	3/2017	Ding	D14/486
D783,676	S *	4/2017	Kim	D14/489
D787,527	S *	5/2017	Wilberding	D14/485
2015/0355786	A1 *	12/2015	Sabatelli	G06F 3/0481 715/798
2017/0003875	A1 *	1/2017	Sheng	G06F 3/04886

* cited by examiner

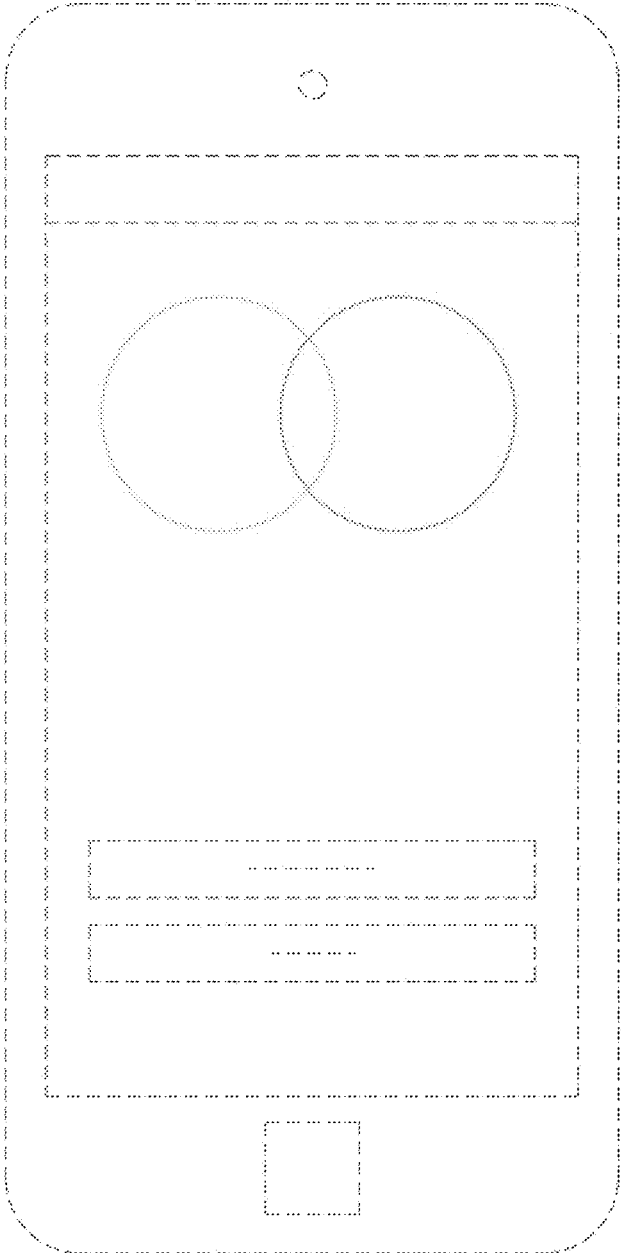

Fig. 1

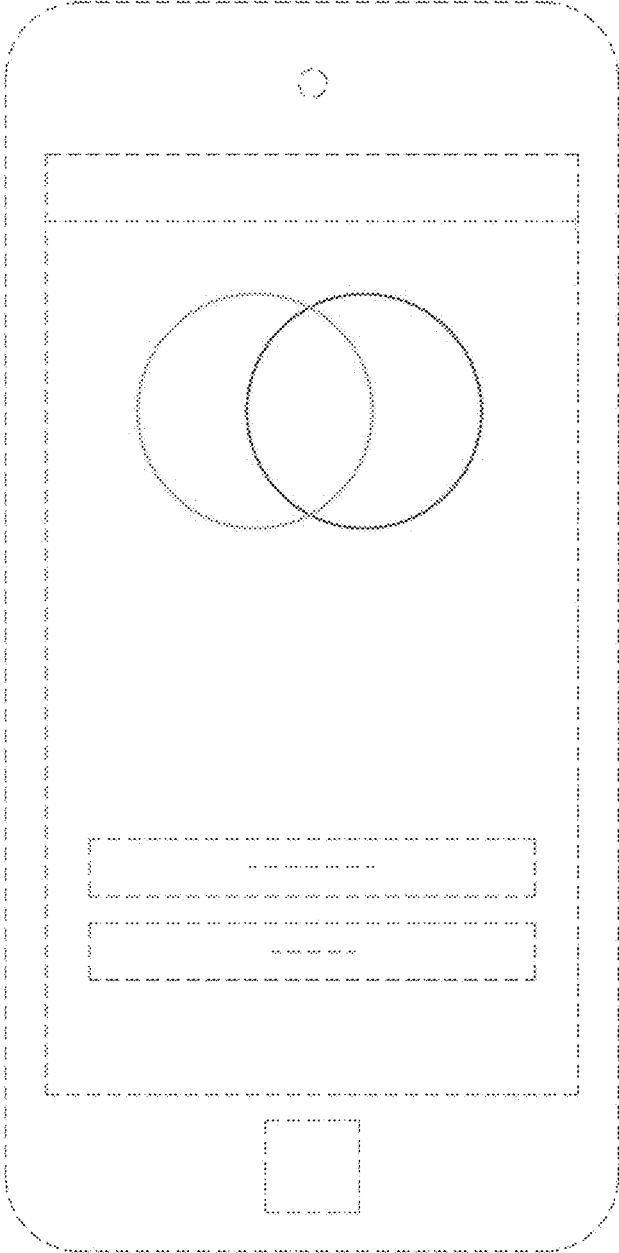

Fig. 2

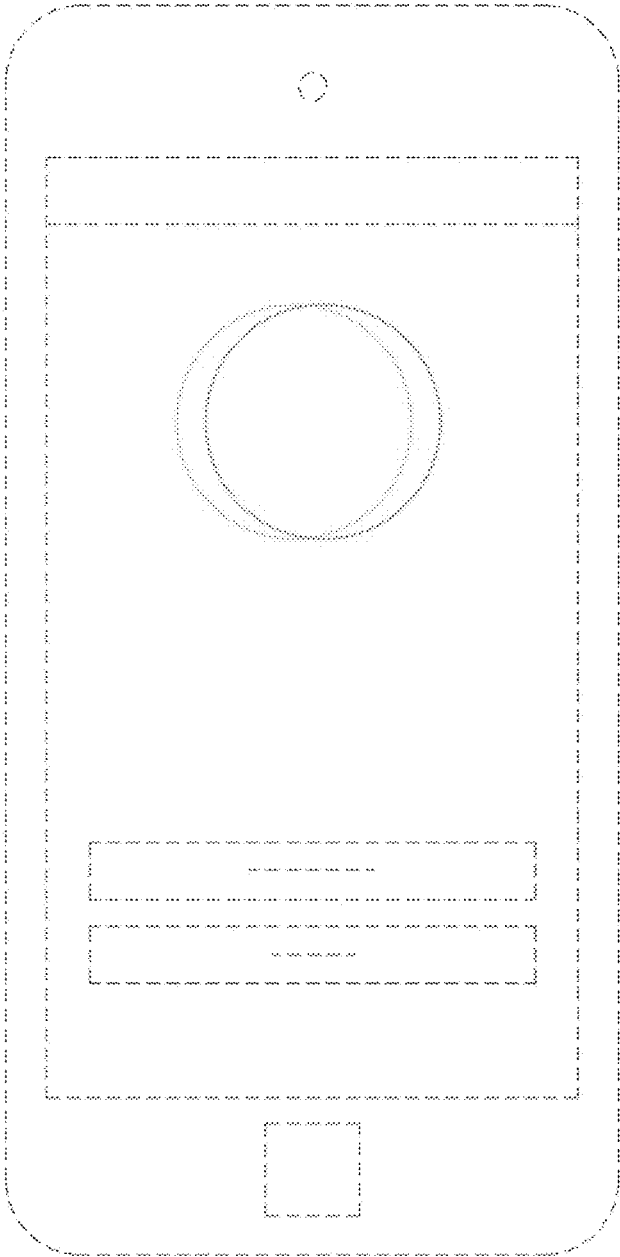

Fig. 3

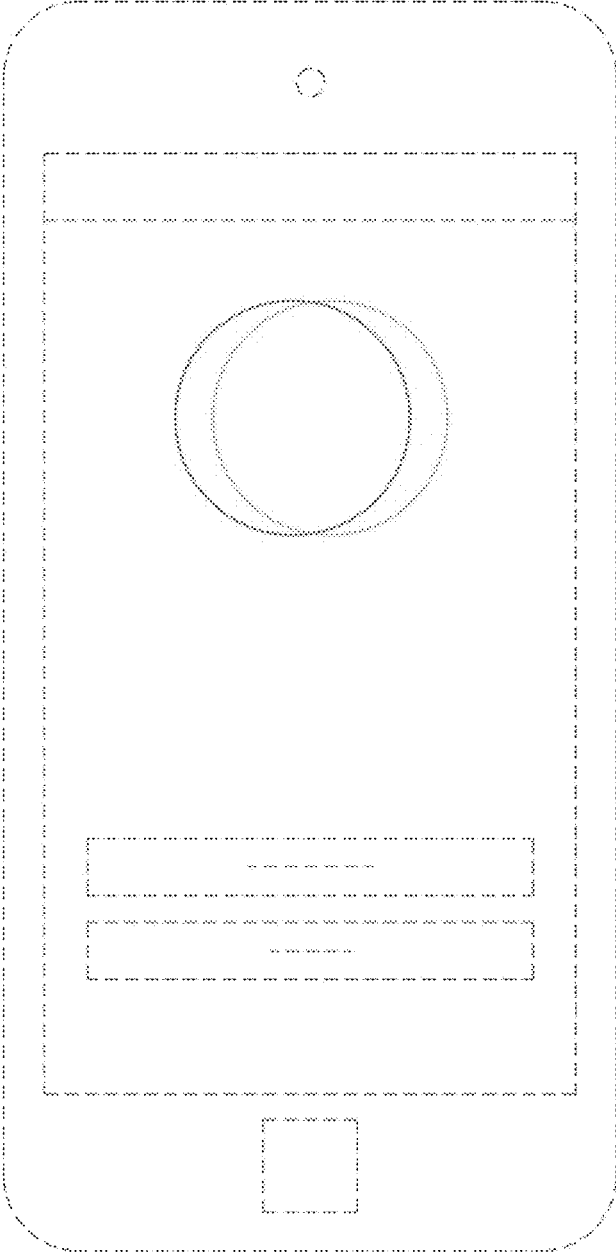

Fig. 4

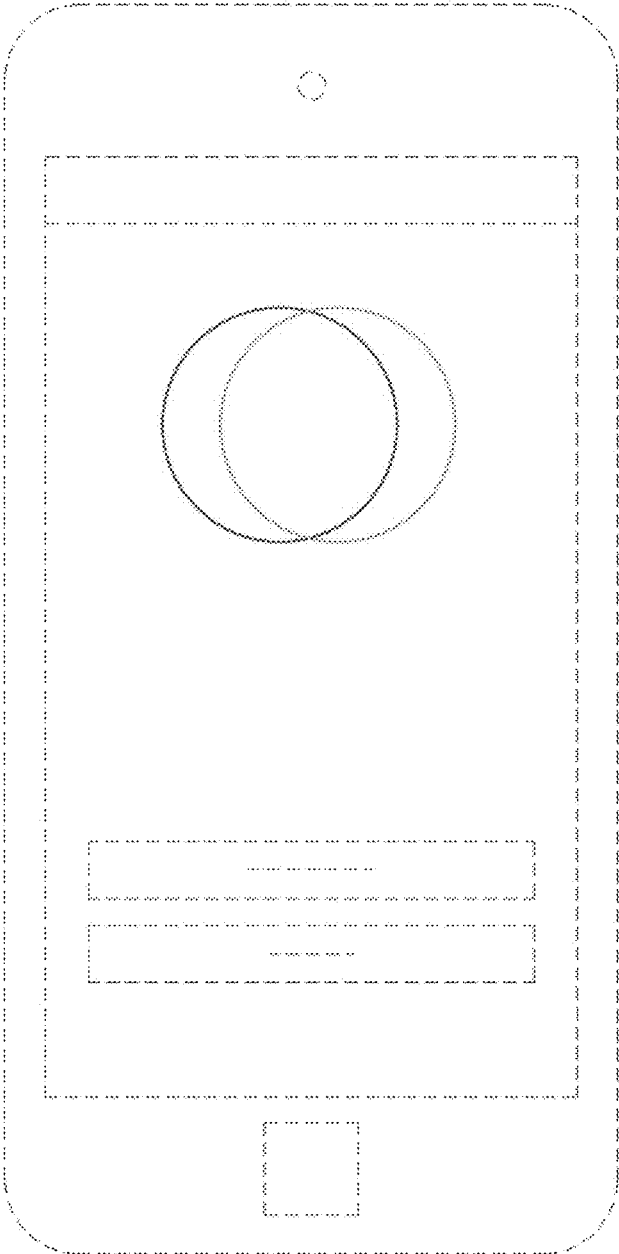

Fig. 5

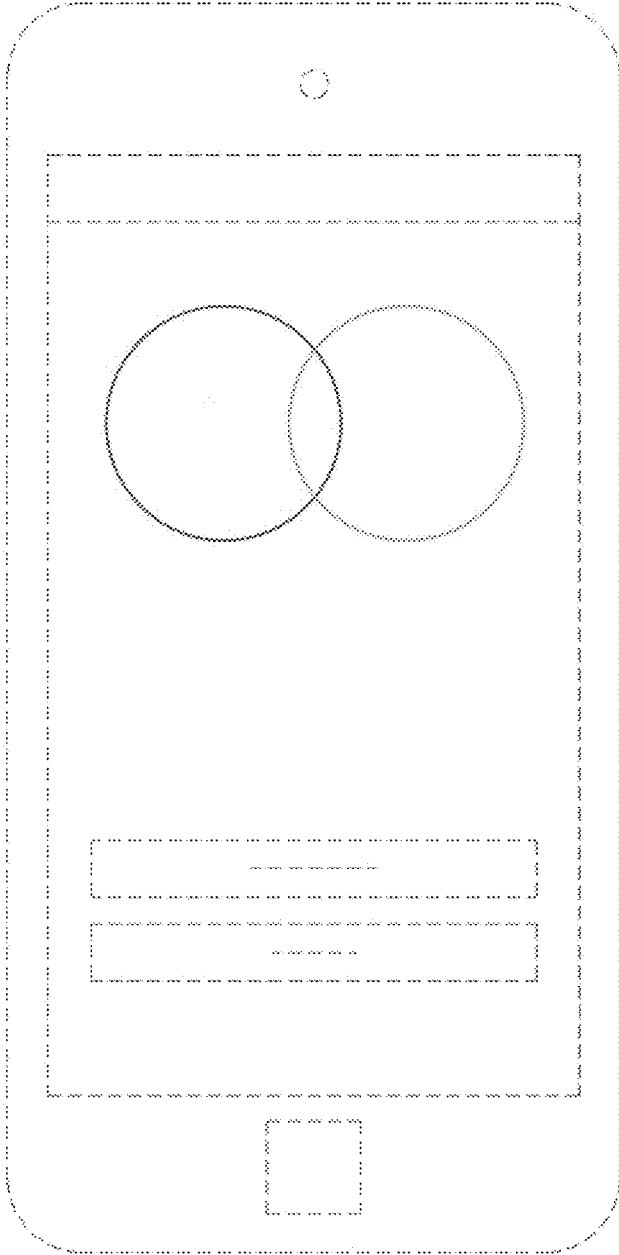

Fig. 6

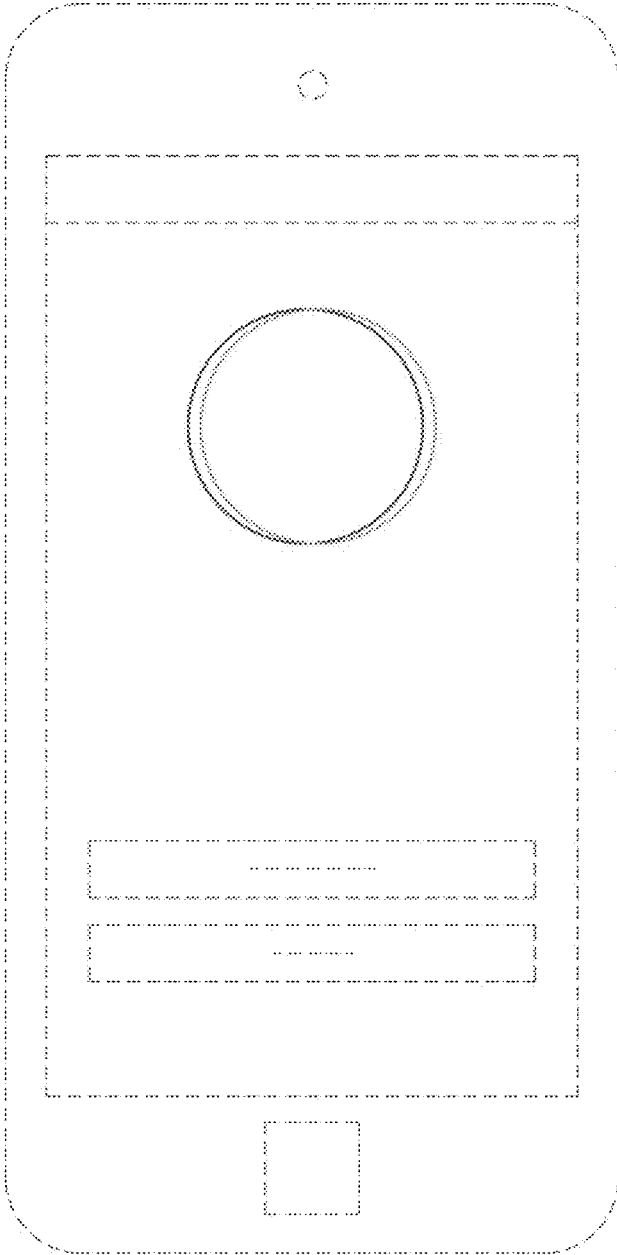

Fig. 7

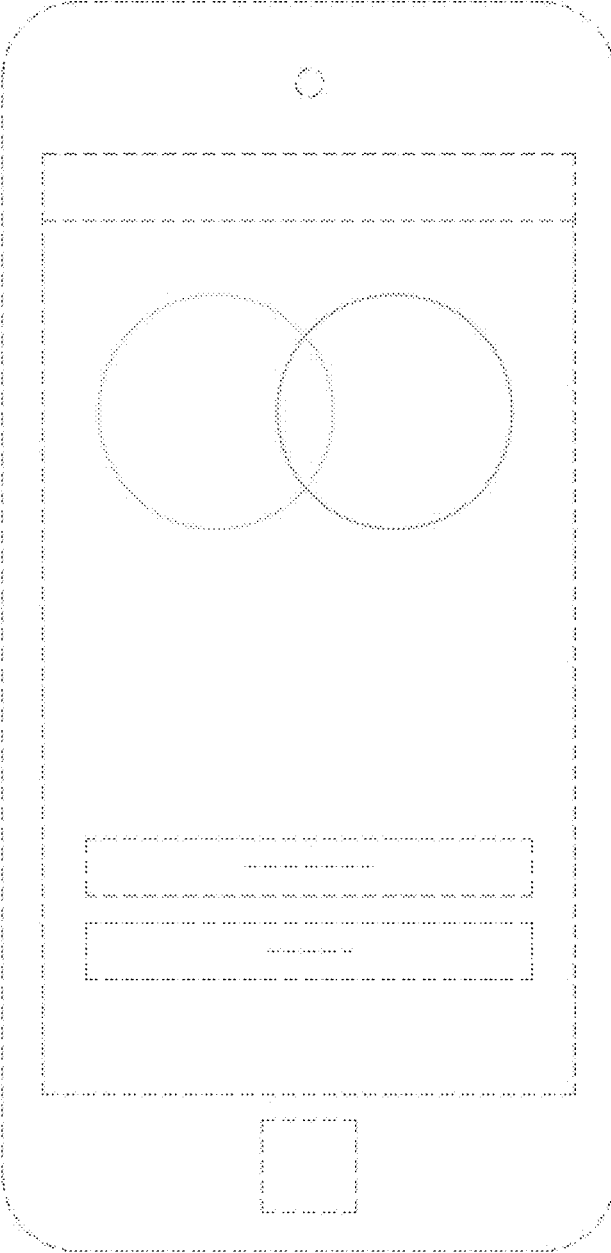

Fig. 8

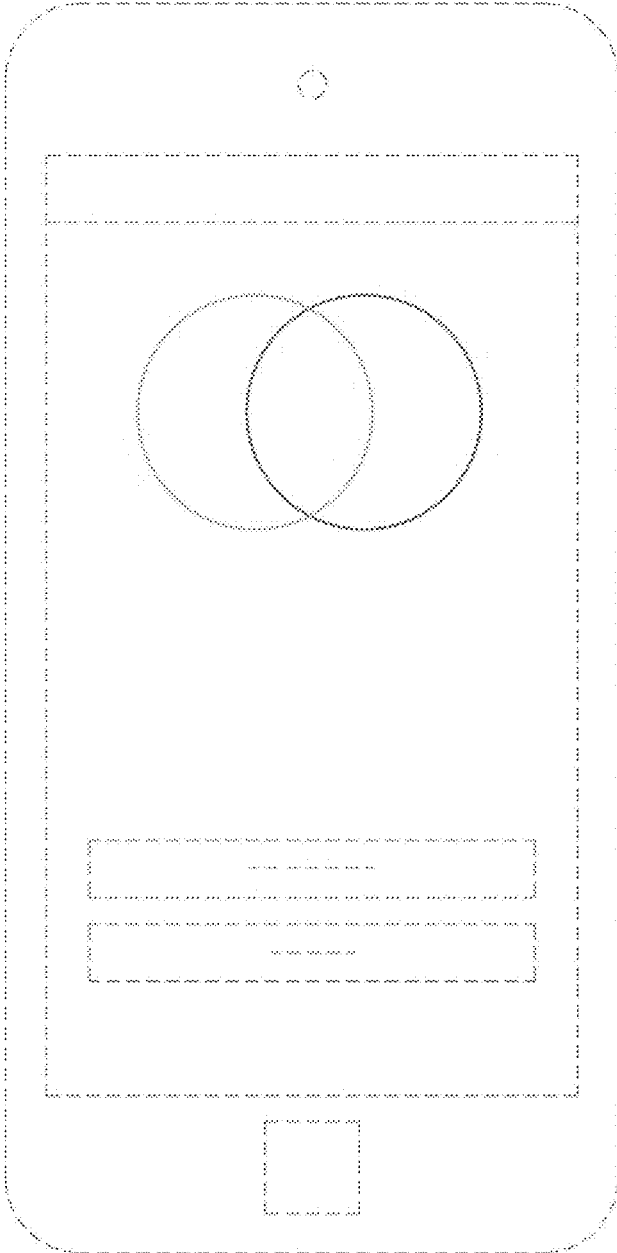

Fig. 9

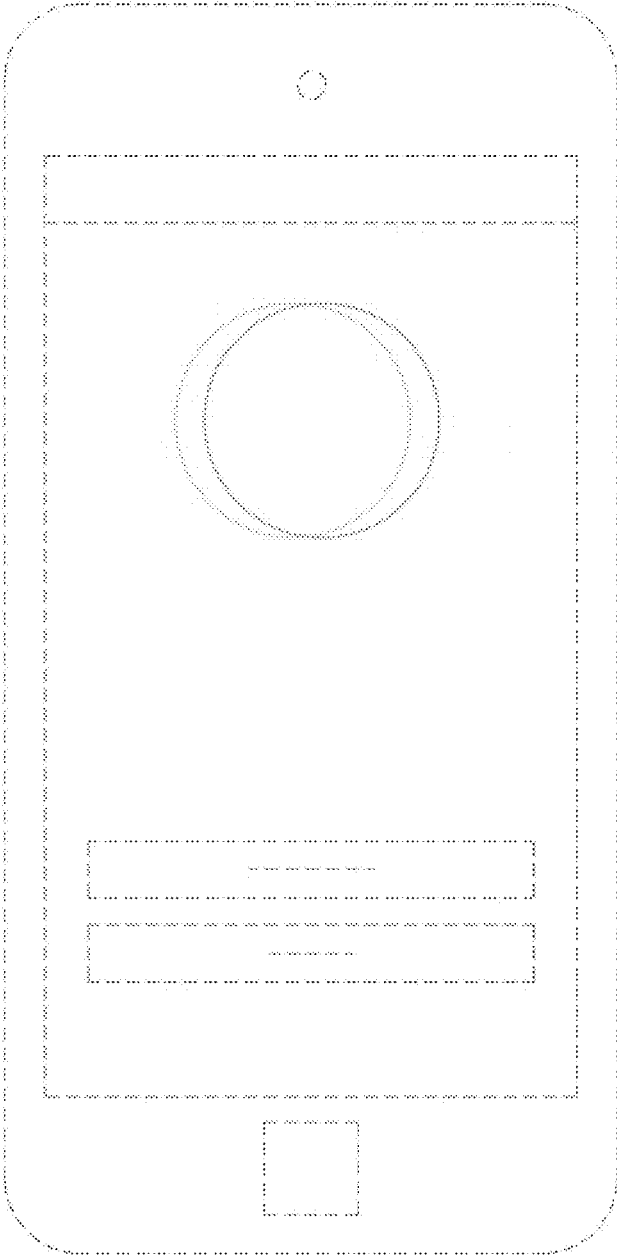

Fig. 10

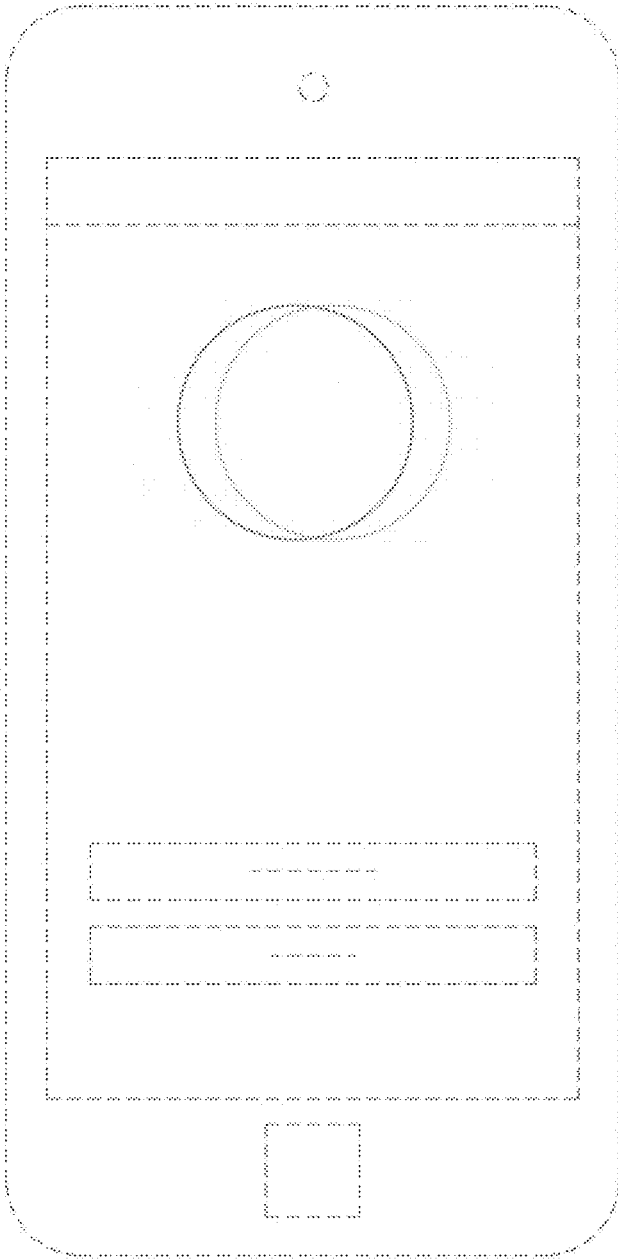

Fig. 11

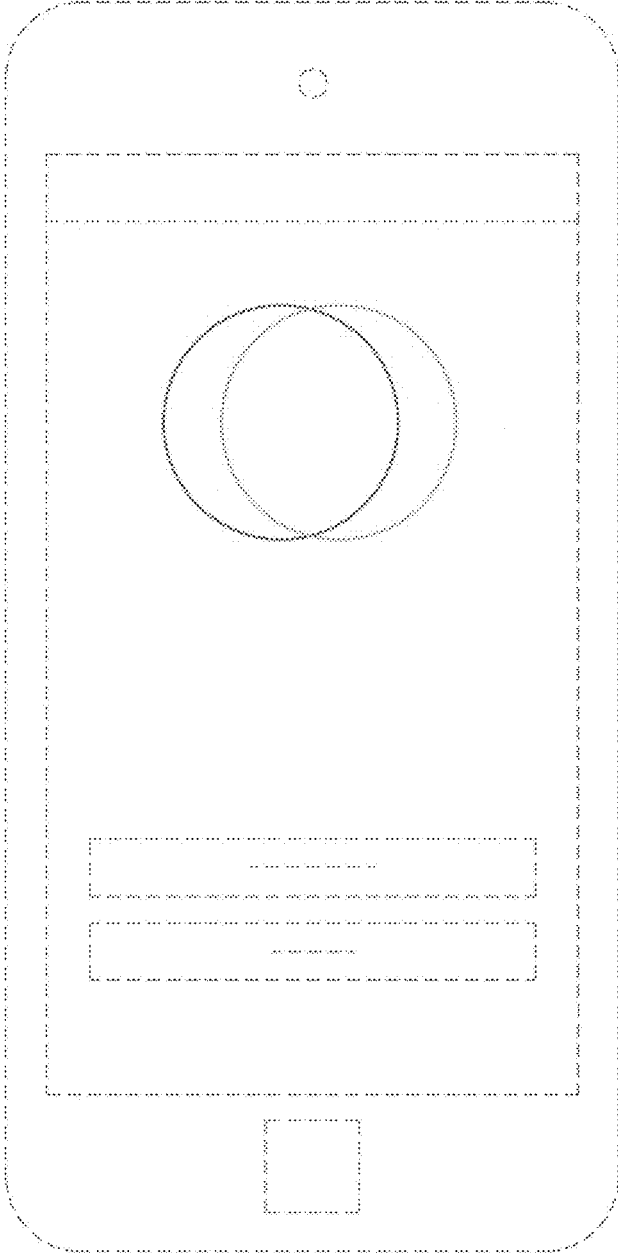

Fig. 12

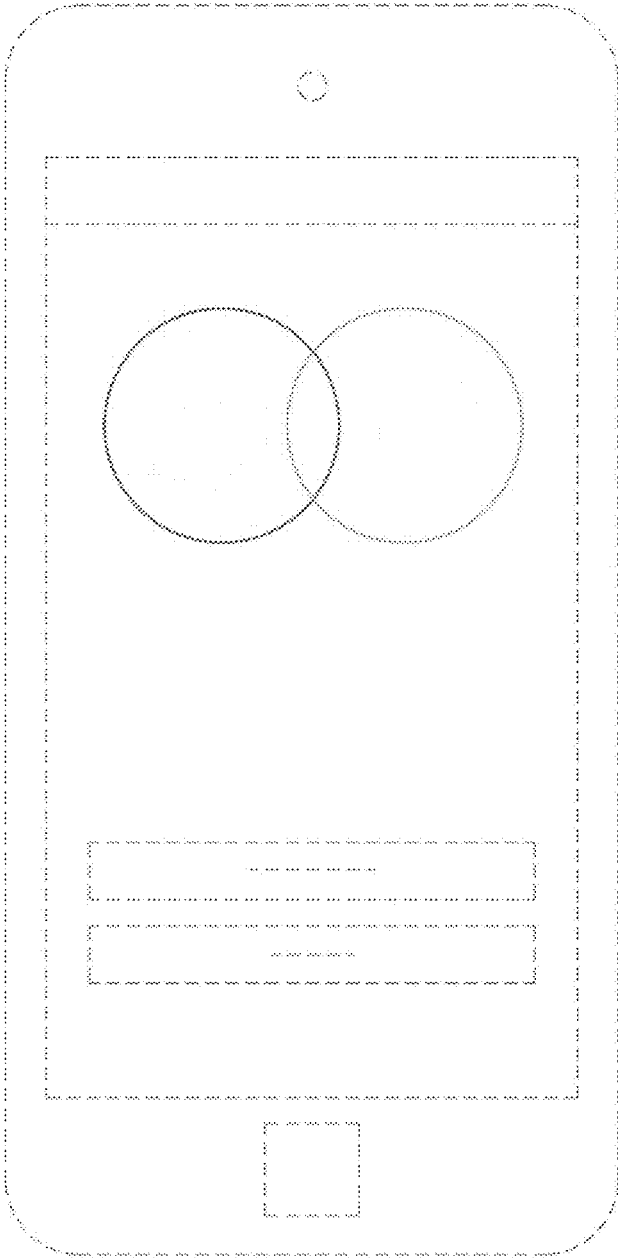

Fig. 13

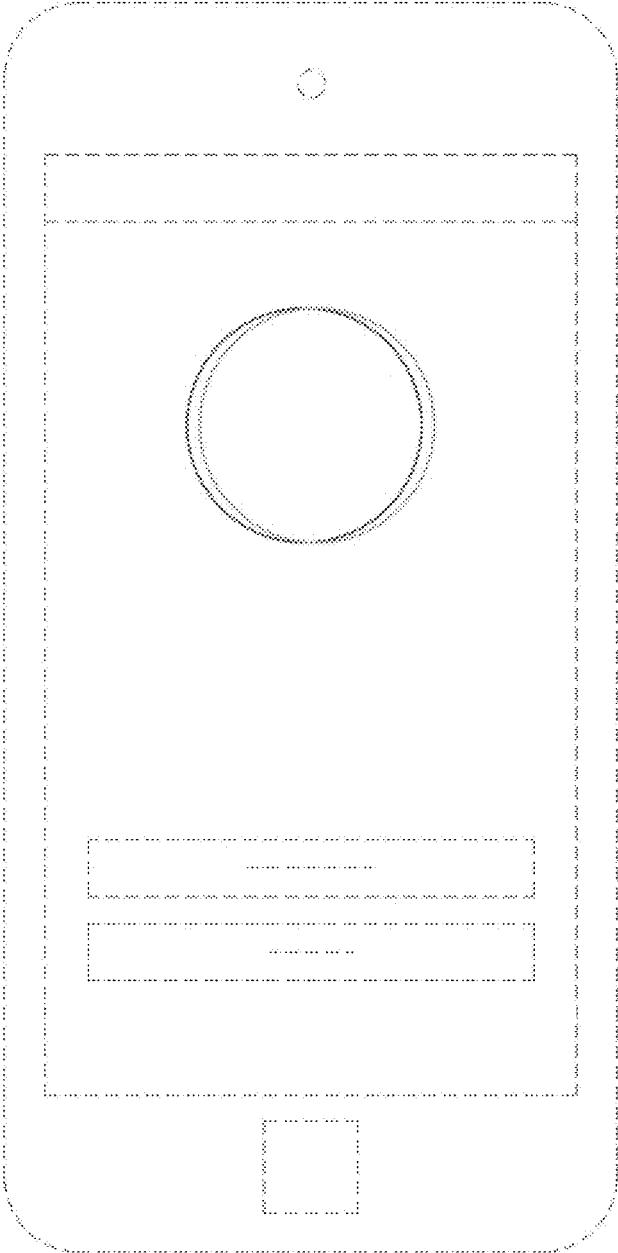

Fig. 14