

(19) World Intellectual Property  
Organization  
International Bureau



(43) International Publication Date  
17 June 2004 (17.06.2004)

PCT

(10) International Publication Number  
**WO 2004/049794 A2**

- (51) International Patent Classification<sup>7</sup>: **A01K 67/027**, C07K 16/00, C12N 5/10
- (21) International Application Number:  
PCT/GB2003/005274
- (22) International Filing Date: 3 December 2003 (03.12.2003)
- (25) Filing Language: English
- (26) Publication Language: English
- (30) Priority Data:  
0228210.1 3 December 2002 (03.12.2002) GB
- (71) Applicant (for all designated States except US): **THE BABRAHAM INSTITUTE** [GB/GB]; Babraham Hall, Babraham, Cambridge CB2 4AT (GB).
- (72) Inventor; and
- (75) Inventor/Applicant (for US only): **BRÜGGEMANN, Marianne** [DE/GB]; 2 Station Road, Foxton, Cambridge CB2 6SA (GB).
- (74) Agent: **ROBERTS, Michael, Austin**; Reddie & Grose, 16 Theobalds Road, London WC1X 8PL (GB).
- (81) Designated States (national): AE, AG, AL, AM, AT, AU, AZ, BA, BB, BG, BR, BW, BY, BZ, CA, CH, CN, CO, CR, CU, CZ, DE, DK, DM, DZ, EC, EE, EG, ES, FI, GB, GD, GE, GH, GM, HR, HU, ID, IL, IN, IS, JP, KE, KG, KP, KR, KZ, LC, LK, LR, LS, LT, LU, LV, MA, MD, MG, MK, MN, MW, MX, MZ, NI, NO, NZ, OM, PG, PH, PL, PT, RO, RU, SC, SD, SE, SG, SK, SL, SY, TJ, TM, TN, TR, TT, TZ, UA, UG, US, UZ, VC, VN, YU, ZA, ZM, ZW.
- (84) Designated States (regional): ARIPO patent (BW, GH, GM, KE, LS, MW, MZ, SD, SL, SZ, TZ, UG, ZM, ZW), Eurasian patent (AM, AZ, BY, KG, KZ, MD, RU, TJ, TM), European patent (AT, BE, BG, CH, CY, CZ, DE, DK, EE, ES, FI, FR, GB, GR, HU, IE, IT, LU, MC, NL, PT, RO, SE, SI, SK, TR), OAPI patent (BF, BJ, CF, CG, CI, CM, GA, GN, GQ, GW, ML, MR, NE, SN, TD, TG).

**Published:**

— without international search report and to be republished upon receipt of that report

For two-letter codes and other abbreviations, refer to the "Guidance Notes on Codes and Abbreviations" appearing at the beginning of each regular issue of the PCT Gazette.



**WO 2004/049794 A2**

(54) Title: SINGLE CHAIN ANTIBODIES

(57) Abstract: The present invention concerns single chain antibodies. The invention includes a transgenic mouse and single chain antibodies produced by such a transgenic mouse. The transgenic mouse may in one aspect be capable of expressing a single chain antibody, such as a heavy chain only antibody, in which expression includes either extracellular display or secretion or both.

### Single Chain Antibodies

The present invention relates to single chain antibodies. In particular, the invention includes a transgenic mouse capable of expressing single chain antibodies and single chain  
5 antibodies produced by such a transgenic mouse.

#### **Classical immunoglobulins**

Classical antibodies (Abs), and particularly immunoglobulins (Igs), are present in plasma of mammalian species as units of paired heavy (H) and light (L) chains. Each H chain  
10 consists of an N-terminal variable ( $V_H$ ) domain of ~110 amino acids linked to 3 or 4 constant (C) domains of similar size ( $C_{H1}-C_{H3}$  or  $C_{H1}-C_{H4}$ ), while light chains comprise a variable ( $V_L$ ) domain and a single C domain,  $C_L$ . The pairing of H and L chains creates the conventional antigen combining site through the association of  $V_H$  and  $V_L$ , each domain contributing 3 sets of hypervariable or complementarity determining regions (CDRs) via  
15 which contact is made to antigen. Each H-L pair is itself dimerised ( $H_2L_2$ ), being linked by disulphide bridges connecting the H chains.

There are 5 major H chain isotypes ( $\mu$ ,  $\gamma$ ,  $\alpha$ ,  $\epsilon$ ,  $\delta$ ), which characterise the 5 Ig classes (M, G, A, E and D) and vary in the number of C domains (3 for  $\gamma$ ,  $\alpha$ ,  $\delta$  or 4 for  $\mu$ ,  $\epsilon$ ). There  
20 are two L chain isotypes ( $\kappa$ ,  $\lambda$ ) which may occur in combination with any H chains. The Ig classes differ in the number of  $H_2L_2$  units they contain; thus IgG, IgD and IgE are single  $H_2L_2$  units, while IgA is a dimer (2 x  $H_2L_2$ ) and IgM a pentamer (5 x  $H_2L_2$ ). A detailed review of Ig and antibody structure can be found in Padlan, E.A., Molecular Immunology 1994, 31: 169-217.

25

The route to development of mature classical antibody producing B cells is well established. Early 'pre-B' cells first rearrange H-chain  $V_HDJ_H$  segments and proceed to express  $\mu$  heavy chains on their surface, in association with a surrogate light chain. Subsequently a  $\kappa$  or  $\lambda$  light chain is rearranged and expressed in combination with the H  
30 chain. The B cell receptor (BCR) of naïve mature B cells thus includes monomeric IgM ( $H_2L_2$ ), together with associated signalling domains. After activation and IgM secretion, the process of antibody maturation ensues, during which B cells bearing other Ig isotypes

(IgG, IgA and IgE) are produced by class switching and undergo further selection. Affinity maturation involves a process of hypermutation of the  $V_H$  and  $V_L$  regions and selection by antigen of binding sites of improved affinity and specificity.

## 5 Camelid immunoglobulins

In addition to the characteristic classical structures of mammalian Ig's described above, sera of camelids (camels, dromedaries and llamas) contain a major type of Ig composed solely of H-chains (Heavy-chain Abs or HCAs) without L chains (Hamers-Casterman *et al.*, 1993, Nature 363: 446). In such single chain antibodies, the combining site is formed  
10 by a single  $V_H$  domain, termed  $V_{HH}$ . In HCAs, the H chains occur as disulphide bridged dimers. The H chains lack the first constant domain ( $C_{H1}$ ) (Muyldermans *et al.*, 1994, Protein Engineering 7: 1129). The genes encoding the H-chain contain the CH1 exon, which is spliced out during mRNA maturation as a result of a point mutation at the canonical splicing donor site (Nguyen *et al.*, 1999, Mol.Immunol. 36: 515). Single chain  
15 HCAs are absent in other mammals except in pathological cases (i.e. heavy chain diseases), where various parts of the  $V_H$  domain and the  $C_{H1}$  are eliminated due to DNA rearrangements.

The generation of HCAs in the camelid species also relies on the use of specific  $V_{HH}$   
20 genes (Nguyen *et al.*, 2001, Adv Immunol. 79: 261), which differ from  $V_H$  genes used in the generation of conventional Abs as they carry changes in some of the codons that encode the residues normally contacting the  $V_L$  domain.

In camelids, the development of B cells producing HCAs is not well understood. Some  
25 observations indicate that the IgM-stage of HCAs is transient and that the conventional IgM pathway might be circumvented in HCAs ontogeny. Possibly a distinct lymphocyte subpopulation might initiate the immune response of the HCAs in camelids. However, the genetic requirements of the BCR and activation in such cells are unknown.

## 30 Production of single chain antibodies *in vitro*

To date, an *in vitro* molecular approach to construction of single domain combining sites has been used in which  $V_H / V_L$  interface mutations are introduced (e.g. G44E, L45R and

W47G) in order to prevent the formation of a domain pair. A repertoire of such single V<sub>H</sub> domains was expressed on phage and selected against haptens and proteins, which led successfully to single V<sub>H</sub> binding domains of moderate affinity (Riechmann and Muyldermans, 1999, J. Immunol. Methods 231: 25; Davies and Riechmann, 1995, 5 Biotechnology 13: 475). However, there will be several advantages in utilising *in vivo* methods for selection of human HCAbs, particularly in the use of transgenic mice.

### Human immunoglobulins in transgenic mice

Because of their clinical therapeutic advantages for treatment of diseases including 10 cancers and infections, several procedures have been explored for production of human antibodies, avoiding immunisation of humans. They include molecular techniques of 'humanisation', in which CDRs from mouse antibodies replace the human CDRs in human V region frameworks, selection of binders from genetic libraries of human antibody combining sites by phage display *in vitro*, and expression of human Ig genes in 15 transgenic mice. In the last of these, elements of the human H and L genetic loci, including V<sub>HS</sub>, D<sub>S</sub>, J<sub>HS</sub> and V<sub>LS</sub> and J<sub>L</sub> segments with C region genes all in germline configuration, are cloned into yeast artificial chromosomes and introduced into mouse embryonic stem cells. In the transgenic animals thus obtained, B cells rearrange the human V genes in normal fashion (i.e. V<sub>H</sub>DJ<sub>H</sub> and V<sub>L</sub>J<sub>L</sub>) and express fully human Ig's, 20 responding to immunisation by production of fully human antibodies. Optimally, the expression of endogenous mouse Ig is suppressed by knockout of the mouse H and L chain loci. A number of different knockout strategies have been employed, such as silencing of H chain expression by deletion of the  $\mu$  chain membrane domain (Kitamura *et al.*, 1991, Nature 350: 423) and inactivation of the L chain locus by deletion of J<sub>L</sub> 25 segments. After immunisation of such multifeature transgenic knockout mice, human monoclonal antibodies can be obtained by the hybridoma method, and such mice are now used for the production of therapeutic human antibodies (for review see Brüggemann and Taussig, 1997, Curr Opin Biotechnol 8: 455).

### 30 Present invention

Significant advantages may be achieved by the use of single domain or single chain antibodies rather than conventional antibodies, for example for human therapeutic or

diagnostic reagents, such advantages deriving from their unique reactivity against active sites of target molecules and rapid tissue penetration. However, it is evident that appropriate new methods are required for their production. The *in vitro* display library approach requires considerable time-consuming and labour-intensive genetic  
5 manipulations and know-how to produce desired binders and in the literature has resulted in selection of human single chain antibodies of relatively low affinity. However, no means currently exists for the production of single chain antibodies in mammals other than those naturally occurring in camelids.

10 According to the present invention, there is provided a transgenic mouse capable of expressing a single chain antibody, in which expression includes either extracellular display or secretion or both.

Transgenic mice of the invention have the capacity to express, on their B cells and/or in  
15 plasma, single chain antibodies. An advantage in the use of animals for the production of classical antibodies lies in the natural process of selection and affinity maturation which occurs in B cells of the immunised animal *in vivo*, resulting in a potentially quicker and easier derivation of desired antibodies.

20 As noted above, the formation of HCABs in camelids appears to require both the involvement of a  $V_{HH}$  germline gene in which the interface residues are modified and the availability of the HCAB-specific  $C_H$  ( $C\gamma$ ) gene. However, the details of transcript processing and the extent of the  $C_{H1}$  removal from the  $V_{H}HDJ-C\gamma$  primary transcript remains presently obscure. Furthermore, because HCABs were observed exclusively in  
25 camelids and not in other mammalian species it was thought that HCAB production may involve camelid-specific accompanying specific factors to process, assemble and express HCAB genes into functional antigen-binding entities. For these reasons, the ability to utilise a noncamelid species to produce *bona fide* HCABs, as demonstrated here for the first time, is an unexpected result.

30

Herein the term 'single chain antibody' designates in a first embodiment an Ig H chain, unpartnered by L chain. The H chain may carry a V region linked to  $C_H$  domains and

capable of binding to antigen ligand via a single V domain. Alternatively, a single chain antibody may designate a combination of the domains of an Ig H and Ig L chain to form a chimeric single chain antibody. A 'single domain antibody', also covered by the present invention, is defined as an unpaired V region capable of binding to an antigen ligand.

5

The single chain antibody of the transgenic mouse may thus be a heavy chain antibody. The single chain antibody may in a further embodiment comprise a heavy chain domain linked to a light chain domain.

10 The transgenic mouse may carry immunoglobulin heavy and/or chain locus genes of a heterologous species for single chain antibody expression. The heterologous heavy and/or light chain locus genes may include  $V_L$  and/or  $V_H$ , and/or D and/or  $J_H$  and/or C genes. A heterologous heavy chain locus gene may be modified (for example by mutation and/or deletion) to allow expression and/or antigen binding of the single chain antibody. For  
15 example, a C region exon (for example, the  $C_{H1}$  exon) of the heterologous heavy chain locus gene may be modified. Alternatively or additionally, the  $V_H$  and/or complementary determining regions (CDRs, i.e. hydrophobic residues located in the conventional  $V_H/V_L$  interface and which take part in domain-domain interaction) may be modified.

20 We have demonstrated previously (see International Patent Application No. PCT/GB02/02867 published as WO03/000737) that deletion of the L chain loci by knockout does not lead to production of single chain antibodies capable of being expressed, indicating that further modification may be required.

25 In one embodiment, the heterologous heavy and/or light chain locus genes in the transgenic mouse are not rearranged and comprise a repertoire of  $V_H$ , D and  $J_H$  segments, or  $V_L$  and  $J_L$  segments, and a constant region gene.

In a further aspect of the invention, the transgenic mouse comprises a repertoire of genes  
30 encoding rearranged or germline variable  $V_H$  or  $V_L$  domains of a heterologous species, modified for single chain antibody expression and optionally antigen binding by modification of variable-region framework and/or CDR residues and/or constant-region

genes.

In the transgenic mouse of the invention, any or all of the endogenous mouse heavy chain genes and/or light chain genes may be modified, functionally silenced and/or deleted. This  
5 can, for example, allow for expression of specific heterologous antibodies only.

The single chain antibody may be in monomeric or multimeric (for example, dimeric) configuration.

10 The transgenic mouse may express a repertoire of single chain antibodies. The heterologous heavy and/or light chain locus genes or the repertoire of genes may undergo rearrangement and expression in mouse B cells. Immunoglobulin gene segments can be rearranged in B cells *in vivo* and the mouse may thus respond to immunisation by production of a variety of single chain Abs, for example, of the heterologous species. For  
15 example, different V<sub>H</sub> genes may be rearranged with different D and J segments.

Mixed loci may be used for the creation of single (e.g. heavy) chain antibody repertoires. It may be advantageous to mix genes or segments of intervening sequences from different species to improve single chain antibody expression.

20

The heterologous species may be mammalian, for example a noncamelid such as a human.

For clinical applications in man, single domain combining sites (as in HCAbs), currently only known naturally in camelids and sharks, would advantageously be of human origin  
25 and potentially combined with human constant regions in order to avoid problems of immunogenicity.

In another aspect of the invention there is provided a method for the production of a transgenic mouse capable of expressing a single chain antibody having a heavy chain or a  
30 heavy chain linked to a light chain, comprising the steps of inserting immunoglobulin heavy or light chain locus genes of a heterologous species into the mouse, allowing expression of the genes to form the single chain antibody which is expressed either by

extracellular display or by secretion or both.

In a further aspect of the invention there is provided a single chain antibody produced by the transgenic mouse as defined above. The single chain antibody may be in the form of a  
5 monomer or multimers in which identical chains are associated. Alternatively, the single chain antibody may be in dimeric or multimeric form such that variable domains of the antibody bind antigen independently.

Also provided according to the invention is a monoclonal or polyclonal heavy chain only  
10 antibody, or a heavy-light chain chimeric antibody, which has a structure including a single domain antigen-combining  $V_H$  or  $V_L$  region and which is made upon immunisation of a mouse as defined above.

Yet further provided is a method for producing a single chain antibody of the invention,  
15 comprising the step of immunising the mouse as defined above with an antigen to elicit an immune response, the immune response comprising antigen-specific antibody production.

Another aspect of the invention is an antibody display library derived from the transgenic mouse as defined above, in which the display library comprises immunoglobulin heavy  
20 and/or light chain genes which are transcribed and translated *in vitro* to encode a population of single chain antibodies. The library may comprise lymphocyte DNA isolated from a mouse as defined above.

Also provided according to the invention is a method for the production of the display  
25 library as defined above, comprising the step of introducing the immunoglobulin heavy and/or light chain genes into a bacterial, yeast, phage or ribosome display system.

A further aspect of the invention is an isolated non-camelid immunoglobulin locus comprising heavy chain genes modified to encode a single chain antibody capable of  
30 being expressed *in vivo*. The locus may further comprise light chain genes. The heavy and light chain genes may comprise variable genes which are modified at their  $V_H/V_L$  interface.



The invention also provides a hybridoma obtainable from a transgenic mouse as defined herein by fusion of a splenocyte from the transgenic mouse with a B-cell tumour line cell (for example an NSO myeloma cell), and subsequent selection of single clones. Also  
5 provided is a single chain antibody, preferably human, obtainable from this hybridoma.

As well as generation of hybridomas, human genes encoding single chain antibodies may be recovered from the immune B cells of transgenic mice by PCR for further genetic manipulation.

10

Whereas the antigen-combining site of a conventional antibody is provided by the association of  $V_H$  and  $V_L$  domains, that of single chain antibodies may include a  $V_{HH}$  domain only and consequently be much smaller in size than that of classical antibodies. This provides single chain antibodies certain advantageous properties, such as the ability  
15 to recognise smaller antigens, for example the binding site clefts on the surfaces of enzymes where active sites are located or canyons on the surfaces of viruses, both regions which may be inaccessible to the combining sites of conventional Abs. In camelids, this may be assisted by the CDR3 region of the HCAb, which may be particularly long and include a disulphide bridge. In addition to their special specificity properties, single  
20 domain combining sites may have advantages as therapeutic and diagnostic agents in their easier penetration into target tissues such as tumours and more rapid clearance from the human body. A further aspect of the invention therefore covers use of single chain antibodies according to the invention as a therapeutic and/or diagnostic agent. Single chain antibodies of the invention may be used in the manufacture of a medicament for the  
25 treatment of a disease, for example cancer.

In another aspect of the invention there is provided a method for producing a repertoire of single chain antibodies in a mouse. The method may use the mouse as defined above. The method may encompass the method for producing the antibody as defined above. The  
30 repertoire may comprise single chain antibodies of the invention as defined above. Also provided according to the invention is a repertoire of single chain antibodies produced by the method.

Various embodiments of the invention will be described below with reference to the accompanying figures, of which:

5 Figure 1: depicts constructs of  $V_{\text{HH}}\text{-}\gamma\text{2a}$  with (" $V_{\text{HH}}\text{-C}\gamma\text{2aTM}$ "; top figure) or without (" $V_{\text{HH}}\text{-C}\gamma\text{2a}$ "; bottom figure) transmembrane (TM) exons;

Figure 2: shows ELISA results detecting hen egg-white lysosyme (HEL)-specific dromedary Ig produced by transfected NSO mouse myeloma cells carrying the  $V_{\text{HH}}\text{-C}\gamma\text{2aTM}$ ,  $V_{\text{HH}}\text{-C}\gamma\text{2a}$  or parental pSV2 vector transcripts. OD = optical density (values at  
10 405 nm);

Figure 3: shows an SDS-PAGE of camel HCAbs from transfected NSO mouse myeloma cells carrying the  $V_{\text{HH}}\text{-C}\gamma\text{2aTM}$ ,  $V_{\text{HH}}\text{-C}\gamma\text{2a}$  or parental pSV2 vector transcripts,  
15 stained with Coomassie brilliant blue (panels A and B) or revealed by Western blotting (panels C and D);

Figure 4: illustrates the predicted structure of two mRNA products, with (panel A, top) and without (panel A, bottom)  $C_{\text{H1}}$ , that could be obtained from a rearranged camel  
20 Ig H-gene. Panels B to D show PCR identification of transcription products from transfected NSO mouse myeloma cells carrying the  $V_{\text{HH}}\text{-C}\gamma\text{2aTM}$ ,  $V_{\text{HH}}\text{-C}\gamma\text{2a}$  or parental pSV2 vector transcripts;

Figure 5: shows flow cytometry of NSO mouse myeloma cells transfected with  $V_{\text{HH}}\text{-C}\gamma\text{2aTM}$  (A, D),  $V_{\text{HH}}\text{-C}\gamma\text{2a}$  (B) or parental pSV2 vector only (C). Panel (D) shows cells  
25 stained with biotinylated rabbit anti-dromedary Ig and with FITC labeled streptavidine prior to (shaded histogram) or after (open profile) incubation with phosphatidyl-inositol-specific phospholipase C (PI-PLC) to reveal BCR configuration;

30 Figure 6: shows PCR analysis of transgenic mice containing the camel  $V_{\text{HH}}\text{-C}\gamma\text{2a}$  transgene;

Figure 7: shows ELISA results detecting camel single chain antibodies detection in transgenic mice containing the  $V_{\text{H}}\text{H-C}\gamma 2\text{a}$  transgene. The left panel shows HEL-specific camel Ig in serum from transgenic mice while the right panel shows HEL-specific camel Ig in serum from normal mouse;

5

Figure 8: shows FACS analysis of B cells in normal mice (left), transgenic mice carrying the  $V_{\text{H}}\text{H-C}\gamma 2\text{a}$  construct in a  $\mu\text{MT}^{-/-}$  heavy chain knockout background (centre), and control  $\mu\text{MT}^{-/-}$  mice (right);

10 Figure 9: shows flow cytometry analysis of B cells from bone marrow (left three rows) and spleen (right three rows) from normal F1 mice,  $\mu\text{MT}$  mice and two separately generated camel heavy chain mice bred to homozygosity with  $\mu\text{MT}$  animals, viz.  $\text{camIgH}(1) \mu\text{MT}$  and  $\text{camIgH}(2) \mu\text{MT}$ ;

15 Figure 10: depicts a IgH YAC construct (prior art) from Nicholson, I.C. *et al.* (1999) *J. Immunol.* 163: 6898-6906; and

Figure 11: depicts a IgH  $\gamma^{\text{A}}$  YAC construct which is modified from the IgH YAC construct of Figure 10 by truncation and removal of the C gene.

20

### Experimental

In the examples provided below, we have demonstrated herein the expression of a rearranged camelid single chain antibody in transfected mouse myeloma cells (Example 1). The expression of the camel  $V_{\text{H}}\text{H-}\gamma 2\text{a}$  gene followed by the proper mRNA processing, translation, folding and secretion of functional HCAb by the mouse myeloma cell line proves that the HCAb features are all imprinted into the germline genes, and that additional camel-specific infrastructures are not essential or can be by-passed by the mouse transcription, translation and secretion mechanisms. Moreover, in Example 2 we demonstrate the presence of camelid HCAb in the plasma of transgenic mice carrying the HCAb  $V_{\text{H}}\text{H-}\gamma 2\text{a}$  gene. In Examples 3 and 4, we demonstrate and analyse the rescue of B cell development in heavy chain knockout mice by the HCAb transgene. Examples 5 to 7 relate to expression of appropriately modified human  $V_{\text{H}}$  or  $V_{\text{L}}$  genes as single chain antibodies in transgenic mice.

15

#### **Example 1: A camel heavy-chain antibody secreted and displayed by mouse myeloma cells**

This work is focused on the first step in construction of transgenic mice expressing HCAb, i.e. whether mouse B cells can express heterologous HCAs derived from Camelidae species. Rearranged camel H-genes encoding HCAb ( $V_{\text{H}}\text{H-}\gamma 2\text{a}$ ) with and without the transmembrane ("TM") bound region were constructed and their expression, processing and assembly in mouse NSO myeloma cells were examined. A camel H chain gene encoding a HCAb IgG2a isotype with specificity for hen egg-white lysozyme (HEL) was reconstituted and electroporated into the NSO mouse myeloma cell line, which has no endogenous Ig H or L chain expression. The  $C_{\text{H}}1$  domain exon was present in the recombinant gene, but was removed efficiently from the heterologous H-chain transcripts within the cell. HEL-specific HCAs were secreted as disulfide linked homodimers with MW (2 x 50 kDa) as found for the HCAs naturally occurring in camel serum. Antigen-binding HCAs were displayed on the surface of the mouse cell as GPI-linked B cell receptors (BCR) when the transmembrane exons were present in the recombinant gene. The possibility of obtaining expression of a BCR in a HCAb format suggests that

30

maturation of HCAs could occur in complete absence of L-chains. The findings demonstrate the feasibility of the expression and maturation of HCAs in mouse B cells.

*Construction of a dromedary V<sub>H</sub>H- $\gamma$ 2a H-chain gene*

- 5 The rearranged H-chain genes, constructed from V<sub>H</sub>H and C $\gamma$ 2a genes used in the dromedary to form HCAs, are shown in Figure 1. The two constructs differ in the presence or absence of the transmembrane TM region and represent a camel rearranged gene in a genomic configuration with appropriate 5' and 3' regions to allow expression.
- 10 DNA manipulations were carried out using standard PCR and DNA subcloning techniques (Sambrook J, *et al.* 1989, In: A laboratory manual. Cold Spring Harbor Laboratory Press, especially pp. 2.64-2.68; 6.3-6.15; 6.16-6.22; 9.14-9.23). In intermediate cloning steps, recombinant plasmids (pBluescript) were propagated in *E.coli* DH5 $\alpha$  cells, and DNA was prepared using a Qiagen-mini® prep kit (Qiagen, Westburg, Leusden, The Netherlands).
- 15 The cloning strategy was as follows: the Ig promoter region derived from the germline V<sub>H</sub>H clone cvhhp11 (Nguyen *et al.*, 2000, EMBO J. 19: 921-930) was spliced by overlap PCR with the FR1 region of the V<sub>H</sub>HDJ gene encoding the lysozyme-specific cAb-Lys3 (Desmyter A. *et al.*, 1996, Nat. Struct. Biol. 3: 803-811). The region from J<sub>H</sub>5 to the C<sub>H</sub>1 exon of the C $\gamma$ 2a gene rearranged to a V<sub>H</sub>HDJ part with unknown specificity (clone rg122
- 20 obtained by PCR; see Fig. 1) was added as a BstEII-EcoRI fragment, and the remaining exons of the C $\gamma$ 2a gene in germline configuration (clone ch51666; Nguyen *et al.*, 1999, Mol. Immunol. 36: 515, including both transmembrane (TM) exons, were added on an EcoRI-SalI fragment (Fig. 1). The 11.7 kb H-chain construct, including the TM segments on a NotI-SalI fragment, and the 7.4 kb H-chain construct, without the TM region on a
- 25 NotI-KpnI fragment, were subcloned into pSV2-Neo#459 (LMB, Cambridge, UK) at pre-introduced NotI-SalI and NotI-KpnI cloning sites, respectively. The constructs were named V<sub>H</sub>H- $\gamma$ 2aTM and V<sub>H</sub>H- $\gamma$ 2a (see Fig. 1).

- The cAb-Lys3 is a V<sub>H</sub>H coding for a HEL-specific single domain antibody fragment. The
- 30 arrow at the left in Fig. 1 denotes the Ig promoter starting with the conserved Ig octamer sequence. The other gene components are boxed: the rearranged V<sub>H</sub>HDJ region encoding the cAb-Lys3 sequence, the J<sub>H</sub>6 (not used in the D-J recombination), the enhancer (E),

matrix attachment region (MAR) and switch region and the different exons (C for constant domains and M for transmembrane regions) of the dromedary C $\gamma$ 2a are indicated. The position of the NotI, BstEII, EcoRI, Sall and KpnI restriction enzyme sites used during cloning and screening are indicated as well as the position of the stopcodons (\$). The star denotes the non-canonical splicing site at the 3' end of the C<sub>H1</sub> of the camel C $\gamma$ 2a gene. The V<sub>H</sub>H-C $\gamma$ 2aTM construct (Fig. 1, top) of 11.7 kb is the part comprised between the unique NotI and Sall sites, and the V<sub>H</sub>H-C $\gamma$ 2a construct (Fig. 1, bottom) of 7.4 kb, comprised between the NotI and KpnI sites, lacks the membrane bound exons. (The space between E-MAR and switch region is not to scale.)

10

#### *Transfected NSO cells secrete HEL-specific Abs*

The V<sub>H</sub>H- $\gamma$ 2aTM or the V<sub>H</sub>H- $\gamma$ 2a gene constructs or the parental pSV2-Neo cloning vector used as control were electroporated separately into NSO myeloma cells (Desmyter A. *et al.*, 1996, *supra*) by 2 pulses using a BIORAD Gene Pulser set at 230 V and 500  $\mu$ F. The transfected NSO cells were maintained at 37°C and 5% CO<sub>2</sub> in RPMI 1640 medium containing 10% FCS. After 24 hrs of growth, G418 (Invitrogen, Paisley, UK) was added to a final concentration of 400  $\mu$ g/ml. At least 5 antibiotic resistant clones were chosen for each construct and grown to a density of 2-3x10<sup>5</sup> cells/ml for further studies.

HEL (10  $\mu$ g/ml in PBS) was coated overnight at 4°C onto 96-well-plates (Nunc-Maxisorb<sup>TM</sup>, Life Technologies, Invitrogen, Merelbeke, Belgium). Residual protein binding sites were blocked with PBS-1% casein for 2 hrs at room temperature. Serial five-fold dilutions (100  $\mu$ l) of cell-free supernatants from different clones of the transfected NSO cells were added to the wells and incubated at room temperature for 1 hr. The retention of recombinant HEL binding Abs (anti-HEL-IgG2a) was detected with rabbit anti-camel IgG (1/1000 anti-dromedary rabbit serum R17, provided by T. Serrao, VUB, Brussels) and alkaline phosphatase-conjugated goat IgG directed against rabbit IgG (Sigma-Aldrich, Gillingham, UK) and p-Nitrophenyl Phosphate (pNPP) as substrate. Substrate hydrolysis was blocked after 15 min reaction with 1/10 volume of 0.5M EDTA and the plates were read at OD 405 nm in a microtiter plate reader (Elx808, Bio-Tek Instruments, Winooski, Vermont).

Figure 2 shows the HEL specific recombinant molecules of three individual clones (clones 1, 2 and 3) identified using the above ELISA. The positive control (Ctrl+) contains camel anti HEL antiserum diluted 1/5000. Clones 1 and 3 for constructs  $V_{\text{H}}\text{H-}\gamma 2\text{aTM}$  and  $V_{\text{H}}\text{H-}\gamma 2\text{a}$  respectively gave ELISA signals similar to those of the positive control and were inhibited by free HEL (not shown). These results demonstrate that murine NSO cells transfected with the  $V_{\text{H}}\text{H-}\gamma 2\text{aTM}$  or  $V_{\text{H}}\text{H-}\gamma 2\text{a}$  constructs can express a camel H-chain gene and secrete antigen-specific products as a result of correct splicing, translation and intracellular folding.

#### 10 *Dromedary HCAs produced in mouse cells*

The camel HCAs secreted by the NSO cells were characterized by SDS-PAGE and Western blotting, after absorption and elution from HEL-coupled Sepharose, or visualized by Western blot using rabbit anti-camel IgG (Figure 3). Recombinant HCAb was enriched on immuno-adsorbent obtained by coupling HEL to CNBr-activated Sepharose (Amersham Pharmacia, Little Chalfont, UK) (3 mg HEL per ml resin) in 0.5 M NaCl and 0.1 M  $\text{NaHCO}_3$  pH 8.3 following the instructions provided by the manufacturer. HEL-coupled Sepharose (50  $\mu\text{l}$  wet gel) was incubated with 0.5 ml culture supernatant of the different NSO transfectants for 1 hr at room temperature and washed repeatedly with PBS. The captured proteins were solubilized by adding 100  $\mu\text{l}$  SDS-sample buffer, boiled and 4  $\mu\text{l}$  applied to a 10% polyacrylamide gel. SDS-PAGE was carried out under reducing (0.5% DTT in the loading buffer) and non-reducing conditions. Fractionated IgG1 Abs and IgG2 HCAs isolated from dromedary serum were applied in adjacent lanes as references. To visualize the proteins after electrophoresis, gels were stained using Coomassie Brilliant Blue. For Western blot analysis, proteins separated on SDS-PAGE were transferred onto nitrocellulose membranes (Amersham Pharmacia), using a Mini Trans-Blot Cell (BioRad, Nazareth EKE, Belgium) and following standard protocols (Galfre *et al.*, 1982, *Immunology* 45: 125-128). The recombinant IgG2a enriched by adsorption was detected with rabbit anti-dromedary serum as first Ab, alkaline phosphatase-conjugated goat anti-rabbit IgG as second Ab (the same reagents as in ELISA), and 5-bromo-4-chloro-3-indolyl-phosphate and nitroblue tetrazolium (BCIP/NBT, Sigma-Aldrich) as substrate.

Culture supernatant was applied from NSO cells transfected with V<sub>H</sub>H-C $\gamma$ 2a-TM (Fig. 3, lanes 1), V<sub>H</sub>H- C $\gamma$ 2a (Fig. 3, lanes 2) and parental pSV2 vector only (Fig. 3, lanes 3). As controls, the isotypes fractionated from dromedary serum were loaded in adjacent lanes: IgG1, the conventional H-L containing Abs (Fig. 3, lanes 5) and the HCAb IgG2 (Fig. 3, lanes 6). All proteins were separated under non-reducing (Fig. 3, panels A and C) or under reducing conditions (Fig. 3, panel B and D). The molecular weight marker is a prestained protein ladder, and the sizes (in kDa) are given along the bands. The amount of material applied in the Coomassie blue stained gels was ten times higher than in gels revealed by Western blotting.

10

Western blotting revealed a specific protein in the culture supernatants of the NSO transfectants of the V<sub>H</sub>H- $\gamma$ 2aTM or V<sub>H</sub>H- $\gamma$ 2a constructs, the molecular weight of which was below the 114 kDa protein marker under non-reducing conditions, and shifted to ~50 kDa under reducing conditions (Fig. 3, lanes 1 and 2). This result is consistent with disulphide-linked H chain homodimers secreted by the NSO cells as found for HCABs produced by camelids (Fig. 3, lanes 6). The finding (Fig. 3B, D) that the molecular weight of the H chains of the recombinant HCAb (lanes 1 & 2) is lower than that of conventional camel H chains (lane 5) is consistent with the expected absence of the C<sub>H</sub>1 domain. We conclude that the HEL-specific single chain camel Abs are secreted by the transfected NSO cells in a homogeneous form with the MW expected of the IgG2a single chain Abs occurring naturally in camel. The secretion level of the most productive clone (10mg/ml) was similar to the levels obtained from endogenous Abs expressed in myeloma cells.

#### 25 *H chain splicing in transgenic NSO cells*

In order to confirm that the mouse cells do in fact remove the C<sub>H</sub>1 exon from the V<sub>H</sub>H- $\gamma$ 2a(TM) transcript, RT-PCR analysis was performed, with primers to amplify the sequence from the V<sub>H</sub>H FR1 to the hinge region (Figure 4).

30 The QuickPrep micro mRNA purification kit (Amersham Pharmacia) was used for the preparation of mRNA from 10<sup>7</sup> transfected NSO cells and first strand cDNA was synthesized using the 'Ready-to-Go' kit (Amersham Pharmacia). PCR conditions using



0.5  $\mu$ l cDNA were: 30 cycles of 45 s at 94°C, 30 s at 52°C and 45 s at 72°C. Three combinations of specific oligonucleotides allowed the analysis of the C<sub>H</sub>1 splicing junctions: (1) V3FR1B (5' GAGGTGCAGCTGGTGGCGTCTGGAGGAGG 3'; SEQ ID NO: 1), derived from the sequence of the V<sub>H</sub>H/V<sub>H</sub>-FR1 region and G2AHIF (5' GGGACACGTGCATTCTGGTTCA 3'; SEQ ID NO: 2), a sequence annealing at the long hinge region of dromedary C $\gamma$ 2a; (2) V3FR1B and CH1290F (5' CTCTTGTCGACCTTGGTGCTGCTG 3'; SEQ ID NO: 3), representing a conserved sequence of the first constant exon of all camelid C $\gamma$  genes; and (3) CH1242B (5' GCATCTAGACCGMAAGACCTTCACT 3'; SEQ ID NO: 4), a consensus sequence of the first constant exon of all camelid C $\gamma$ , and the long hinge-specific G2AHIF primer. A lack of the C<sub>H</sub>1 exon sequence from the mRNA will result in a ~0.5 kb PCR fragment employing oligonucleotides (1) whilst no amplification products are expected in PCR reactions using oligonucleotide combinations (2) and (3).

Fig. 4(A) illustrates the predicted structure of two mRNA products, with and without C<sub>H</sub>1, that could possibly be obtained from the rearranged camel Ig H-gene. The theoretically possible PCR amplification fragments of these mRNAs are indicated with the expected sizes in kb.

RT-PCR product amplified from the V<sub>H</sub>H-FR1 to the hinge (Fig. 4, panel B), from the V<sub>H</sub>H-FR1 to the C<sub>H</sub>1 (Fig. 4, panel C), and from the 5' C<sub>H</sub>H1 end to the 3' hinge (h) end (Fig. 4, panel D), in which mRNA templates are derived from either, the NSO cells harbouring the dromedary V<sub>H</sub>H-C $\gamma$ 2a-TM gene (lanes 1), V<sub>H</sub>H- C $\gamma$ 2a (lanes 2), parental pSV2 vector (lanes 3) are shown. The fourth lane shows the 123 bp size ladder (position of 123 bp monomer is indicated in panel B). In lane 5, the PCR products of the cloned dromedary Ig- $\gamma$ 1 cDNA possessing the C<sub>H</sub>1 exon. This gives the expected C<sub>H</sub>1 containing fragments of 695 bp (0.7 kb), 646 bp (0.65 kb) and 334 bp (0.3 kb) with primers used to perform experiments shown in B, C and D, respectively.

With oligonucleotides V3FR1B and G2AHIF, the mRNA from the transfected NSO cells as template resulted in a single fragment of 0.5 kb, identifying the transgenic mRNA product without C<sub>H</sub>1 (Fig. 4B, lanes 1 and 2). No band was discerned with a size of 0.8 kb

that would result from the mRNA in which the C<sub>H</sub>1 exon sequences would have been retained. The absence of the C<sub>H</sub>1 exon in the V<sub>H</sub>H- $\gamma$ 2a spliced products was further shown by RT-PCR using C<sub>H</sub>1-specific oligonucleotides which failed to amplify any products (Fig. 4C & 4D, lanes 1 and 2).

5

*Display of HEL-specific HCAs on the mouse cell surface*

Flow cytometry of the NSO transfectants is shown in Figure 5. HEL and affinity-purified rabbit anti-camel IgG were biotinylated using biotin-X-sulfo-NHS (Calbiochem, Nottingham, UK). Clones from the NSO transfectants (10<sup>6</sup> cells) were resuspended in 200  $\mu$ l RPMI medium and incubated with 1 mg biotinylated HEL at 4°C for 45 min. Unbound antigen was removed by two washings with PBS containing 0.002% TritonX-100 and 0.01% sodium azide, and FITC-labeled streptavidin (PharMingen, San Diego, CA) was added to detect cells that captured HEL. After 30 min incubation the cells were washed and resuspended in 2 ml PBS. The cells were analyzed with a FACSvantage flow  
10  $\mu$ l RPMI medium and incubated with 1 mg biotinylated HEL at 4°C for 45 min. Unbound antigen was removed by two washings with PBS containing 0.002% TritonX-100 and 0.01% sodium azide, and FITC-labeled streptavidin (PharMingen, San Diego, CA) was added to detect cells that captured HEL. After 30 min incubation the cells were washed and resuspended in 2 ml PBS. The cells were analyzed with a FACSvantage flow  
15 cytometer (Becton Dickinson, Mountain View, CA). To analyze the H-chain anchorage in the membrane, the cells were incubated with 10U/ml phosphatidyl-inositol-specific phospholipase C (PI-PLC) (ICN, Cedarwood, Basingstoke, UK) prior to staining with biotinylated rabbit anti-camel IgG and FITC-labeled streptavidin. Untreated cells were used as control.

20

Figure 5 shows cells transfected with V<sub>H</sub>H-C $\gamma$ 2a<sup>TM</sup> (A, D), V<sub>H</sub>H-C $\gamma$ 2a (B) and vector only (C) that were incubated with biotinylated HEL and stained with FITC-labeled streptavidin. The background signal obtained when the biotinylated HEL was omitted is superimposed (shaded histograms). In panel D, cells transfected with V<sub>H</sub>H-C $\gamma$ 2a<sup>TM</sup> were  
25 stained with biotinylated rabbit anti-dromedary Ig and with FITC labeled streptavidine prior to (shaded histogram) or after (open profile) incubation with PI-PLC. Each histogram shows the analysis of approximately 10<sup>4</sup> cells.

Labelling of the NSO transfectants carrying the V<sub>H</sub>H-C $\gamma$ 2a<sup>TM</sup> construct, with either  
30 biotinylated HEL, or biotinylated rabbit anti-camel IgG, followed by FITC-labeled streptavidin, led to the identification of surface Ig<sup>+</sup> cells (Fig. 5A and 5D). The surface signal intensity was surprising and implied that heterologous HCAs are efficiently

transported and anchored in the mouse cell membrane. To identify the cell surface anchoring type of the HCABs, transfectants were incubated with phosphatidyl-inositol-specific phospholipase C (PI-PLC) which specifically releases GPI-linked proteins from the cell surface. The results (Fig. 5D) show a net reduction in fluorescence intensity upon  
5 PI-PLC treatment of the cells, reflecting the removal of GPI-linked surface Ig. Therefore, the data demonstrate that camel HCABs devoid of L-chain can be transported to and expressed on the cell surface of NSO mouse cells as a GPI-linked protein.

#### *Summary*

10 The results of Example 1 confirm removal of the CH1 domain by mouse B cells, which allows expression of camel HCAB. In the presence of a transmembrane domain, the HCABs are also found on the B cell surface. This has major implications for the formation of antibody repertoires because the B cell receptor is essential to allow cell survival and progression of B-cell development. The successful expression of HCABs by mouse cells  
15 suggests that developmental regulation of HCABs in a transgenic mouse and in vivo HCAB expression and maturation is feasible.

#### **Example 2: Antigen-specific single chain camel antibodies in transgenic mouse**

20 Mice, and all other healthy non-camelidae mammals studied, do not express single chain antibodies and there are no reports that B-cell development can progress without expression of Ig H and L (light) association on the cell surface. In order to determine whether camel-type H chains could be expressed in a transgenic mouse, retaining their specificity and the effect on B-cell development and B-cell receptor (BCR) configuration,  
25 transgenic mice were constructed.

The  $V_{HH}$ -C $\gamma$ 2a TM construct (see Example 1) was introduced into the germline of F1 CBA x C57BL/6 mice by conventional DNA injection into fertilised mouse eggs (Hogan, B. *et al.* 1994, Production of transgenic mice, In: Manipulating the mouse mouse embryo,  
30 a laboratory manual, Cold Spring Harbour Laboratory Press, pp 217-251).

Following reimplantation into pseudopregnant F1 females, several mice were obtained

carrying the camel heavy chain gene in multiple copies in their genome. Integration of the camel H chain gene was verified by PCR using mouse tail DNA prepared according to Matisse *et al.* (2000, Gene Targeting: A practical approach, Joyner, Ed., Oxford University Press, p.122). PCR was performed using CamIgH Primer 1 (5'-  
5 GCATCTAGACCGGAAAGACCTTCATCT-3'; SEQ ID NO: 5) and CamIgH Primer 2  
(5'-GGGACACGTGCATTCTGGTTCA-3'; SEQ ID NO: 2). PCR conditions were: 94°C  
for 3 min and then 94°C, 55 s; 52°C, 40 s and 72°C, 55 s for 30 cycles with a final  
extension of 10 min. The expected product size is 486 bp.

10 Figure 6 shows the PCR results for the following lanes: 1) control no DNA; 2) normal  
mouse DNA; and 3-6) transgenic camel antibody mice. A  $\lambda$ -based ladder flanks the PCR  
lanes. In lanes 3-6 containing amplification products from transgenic camel antibody  
mice, but not the control and normal mouse DNA lanes, a band of about 486 bp was  
generated (compare with strong 600 bp band of  $\lambda$ -based ladder). The results in Figure 6  
15 confirm that camel-type H chains can be expressed in transgenic mice.

In the camel this  $V_H$  chain is expressed as a single chain antibody in dimeric H2 form with  
specificity for HEL. We could not determine how or whether the antibody produced in the  
transgenic mice are surface-expressed because of the low affinity of the anti-HEL antigen  
20 in the construct. Analysis of expression using anti-camel antibodies was not feasible  
because of their reactivity with other mouse antigens.

In order to confirm expression of the single chain antibody in the transgenic mouse,  
ELISA assays for camel Ig HEL binding activity were carried out using serum obtained  
25 from the tail vein blood from each of the 3 separately derived transgenic founder mice.  
HEL-specific single chain antibodies in serum of transgenic mice carrying the  $V_H$ H-C $\gamma$ 2a  
transgene were detected using 96-well Dynatech microtiter plates coated with 50  $\mu$ l of 10  
 $\mu$ g/ml hen egg lysozyme and blocked with 3% BSA overnight. Serum (50 $\mu$ l) at various  
dilutions (1:10, 1:100, 1:1000 or 1:10000) was added and incubated for 2 hours at room  
30 temperature. Normal mouse serum was used as control. Binding was detected with  
biotinylated antibodies against camel H chain or mouse H and L chain and developed with  
streptavidin horse radish peroxidase and visualised with o-phenyldiamine substrate.

Results shown in Figure 7 demonstrate the presence of camel HCAb against HEL in transgenic, but not normal mouse control, serum, confirming the expression of the HCAb transgene. A detailed serum analysis showed that camel Ig levels were similar to normal  
5 mouse Ig levels and that the camel H chain was not associated with mouse H or L chain.

These experiments demonstrate that it is possible to create transgenic mice producing single chain antibodies and that mouse B cells are therefore able to process the genetic information for such antibodies effectively.

10

**Example 3: Rescue of B cell development by introduction of single heavy chain antibody gene in transgenic mice**

In order to show that the camel HCAb transgenic antibodies can be expressed  
15 independently of B-cells producing mouse antibodies, the transgenic camel HCAb mice of Example 2 above carrying the  $V_HH-C\gamma 2a$  construct were crossed with mice in which the endogenous H chain locus was silenced by gene targeting ( $\mu MT$  mice, Kitamura *et al.*, 1991, *supra*).

20 Flow cytometry analysis (see Example 1 for general method) was carried out using spleen cells. Mice were sacrificed, spleens removed and cell suspensions prepared. Cells were stained using anti-mouse B220 antibodies (01125A, 01129A, PharMingen, San Diego, CA) and for FACS analysis lymphocytes were gated according to their expected size.

25 Results are shown in Figure 8 for normal mice (left), transgenic mice carrying the  $V_HH-C\gamma 2a$  construct in the  $\mu MT^{-/-}$  heavy chain knockout background (centre), and control  $\mu MT^{-/-}$  mice (right). The percentage of B cells in each spleen preparation are indicated. FACS analysis revealed that B cells were rescued in the transgenic mice in the  $\mu MT^{-/-}$  background, with good recovery of B-cell development. Indeed from the results it is clear  
30 that a substantial number of B-cells leave the bone marrow and settle in the spleen. Since the  $\mu MT^{-/-}$  mouse is normally devoid of B cells (see controls in Figure 8), it is clear that the camel HCAb transgene rescues B cell development.

We conclude from these experiments that a single chain antibody of camel origin is successfully processed and expressed in mouse B cells, both when transfected in cell culture and when incorporated into the mouse germline as a transgene.

5

#### **Example 4: B-cell development in mice expressing camel heavy chain antibodies**

Transgenic mice carrying the camel heavy chain gene (were bred to homozygosity with  $\mu$ MT mice in which the endogenous heavy chain locus had been silenced by gene targeting (Kitamura *et al.*, 1991, *supra*). Bone marrow (left three rows) and spleen cells (right three rows) from normal F1 mice,  $\mu$ MT mice and 2 separately generated camel heavy chain mice bred to homozygosity with  $\mu$ MT animals, camIgH(1)  $\mu$ MT and camIgH(2)  $\mu$ MT were stained with labelled antibodies against B220 (universal B-cell marker), c-kit (pro/pre B-cell marker), CD43 (pre B-cell marker), IgM (identifying surface  $\mu$  expression), CD21/35 (identifying mature B-cells that express antibodies) and Ig $\kappa$  (identifying surface  $\kappa$  light chain expression). Analysis was carried out by flow cytometry as described (Zou *et al.*, 2003, J. Immunol. 170, 1354-1361).

The analysis shows (see Figure 9) that introduction of a camel heavy chain gene reconstitutes B-cell development in the  $\mu$ MT background. In bone marrow B220<sup>+</sup> cells (14%) are present in camIgH(2)  $\mu$ MT mice which suggests induced B-cell recovery by expression of the camel heavy chain gene. In the spleen the effect is more dramatic as 25% of mature B-cells, CD21/35<sup>+</sup>, are present in camIgH(2)  $\mu$ MT mice. There is some recovery, 1.1%, in camIgH(1)  $\mu$ MT mice and this low level is likely to be due to the site of integration of the transgene, e.g. in a silencer region. As expected there is no recovery of mouse Ig expression.

The results show that expression of a camel heavy chain allows B-cell recovery in a heavy chain knockout (KO) mouse. This suggests that camel-type heavy chain antibody repertoires can be expressed in the mouse background.

**Example 5: Breeding with heavy (H) and light (L) chain knock-out (KO) mice**

In this example, the feasibility of B-cell development in H chain only mice is tested. The experiments make use of our  $\mu$  truncation mice (see Zou, X. *et al.*, 2001, *Int. Immunol.* 5 13: 1489-1499) which are bred with animals not expressing endogenous mouse L chain genes.

Mice carrying the rearranged camel heavy chain gene (see Example 3 above), were set up for breeding with mice in which the heavy chain locus and, separately, the kappa and 10 lambda light chain locus had been silenced by gene targeting (see Kitamura, D. *et al.*, 1991, *supra*, and International patent application No: PCT/GB02/002867 published as WO03/000737). Homozygous animals were obtained.

Homozygous animals are analysed by flow cytometry to establish the state of B-cell 15 development and IgH expression.

**Example 6: Design of a human heavy chain locus that allows expression of camel-type single chain antibodies in mice**

20 A human IgH YAC with V, D, J and C genes has been described (Nicholson *et al.*, 1999, *supra*; see Figure 10). The human IgH YAC is modified by truncation and removal of the C gene ( $C\mu$  and  $C\delta$  regions). For this a human C gamma ( $\gamma$ ) gene (Flanagan and Rabbitts, 1982, *Nature* 300: 709-713; Brüggemann *et al.*, 1987, *J. Exp. Med.* 166: 1351-1361) without the CH1 exon, obtained by restriction digest or PCR, is subcloned into a YAC 25 arm vector (Burke *et al.*, 1987, *Science* 236: 806-812). To allow homologous integration and C gene truncation, a region 5' of  $C\mu$  ( $C\mu$ ) is added to the human IgH YAC construct. This allows in yeast transfection the replacement of the region comprising the  $\mu$  ( $\mu$ ) and delta ( $\delta$ ) C genes to form a IgH  $\gamma^A$  YAC construct (Figure 11). A loxP sequence can be added to permit future modification of the IgH  $\gamma^A$  YAC construct. Yeast 30 methodologies are described in Guthrie and Fink, 1991, *Methods in Enzymology*, Vol 194, Academic Press). Suitable techniques for YAC modification are described in Popov *et al.*, 1996, *Gene* 177: 195-205 and in International patent application publication No:

WO00/26373.

**Example 7: Introduction of a repertoire of unrearranged genes into mice**

- 5 Protoplast fusion is used for YAC integration of the IgH  $\gamma^A$  YAC construct (see Example 6 and Figure 11) into ES cells. Chimeric mice are produced by blastocyst transfer and breeding established germline transmission. Further breeding with H and L KO mice allows analysis of B-cell development and expression of (diversified) single chain Ig from this modified IgH YAC.
- 10 For methods of YAC introduction and derivation of transgenic mice, see WO 93/05165; Davies, N.P. *et al.* (1996) Human antibody repertoires in transgenic mice: Manipulation and transfer of YACs. In: *Antibody Engineering: A Practical Approach*, J. McCafferty *et al.* (eds), IRL, Oxford, pp. 59-76; Hogan, B. *et al.* (1994a) Isolation, culture, and
- 15 manipulation of embryonic stem cells. In: *Manipulating the mouse embryo, a laboratory manual*, Cold Spring Laboratory Press, pp. 253-289; and Hogan, B. *et al.* (1994b). Production of transgenic mice. In *Manipulating the mouse embryo, a laboratory manual*, Cold Spring Laboratory Press, pp. 217-251.
- 20 If necessary expression of the IgH  $\gamma^A$  YAC can be enforced. For this transgenic mice carrying this YAC are bred with animals not expressing any immunoglobulin genes (see knockout mice in Example 4 above). This establishes a human heavy chain-only antibody repertoire and after immunisation specific single chain antibodies are obtainable.
- 25 It may also be desirable to introduce specific human single chain antibody gene configurations into mice or mice cells so that no rearrangement takes place and "monoclonal" antibodies are produced. *In situ* somatic mutation of these configurations may allow for some optimisation of binding to antigen.



### Claims

1. A transgenic mouse capable of expressing a single chain antibody, in which expression includes either extracellular display or secretion or both.  
5
2. The transgenic mouse according to claim 1, in which the single chain antibody is a heavy chain antibody.
3. The transgenic mouse according to claim 1, in which the single chain antibody  
10 comprises a heavy chain domain linked to a light chain domain.
4. The transgenic mouse according to any of claims 1 to 3, in which the mouse carries immunoglobulin heavy and/or chain locus genes of a heterologous species for single chain antibody expression.  
15
5. The transgenic mouse according to claim 4, in which the heterologous heavy and/or light chain locus genes include  $V_L$  and/or  $V_H$ , and/or D and/or  $J_H$  and/or C genes.
6. The transgenic mouse according to either of claim 4 or claim 5, in which a  
20 heterologous heavy chain locus gene is modified (for example by mutation and/or deletion) to allow expression and/or antigen binding of the single chain antibody.
7. The transgenic mouse according to claim 6, in which a C region exon (for example, the  $C_{H1}$  exon) of the heterologous heavy chain locus gene is modified.  
25
8. The transgenic mouse according to either of claim 6 or claim 7, in which the  $V_H$  and/or complementary determining residues are modified.
9. The transgenic mouse according to any of claims 4 to 8, in which the heterologous  
30 heavy and/or light chain locus genes are not rearranged and comprise a repertoire of  $V_H$ , D and  $J_H$  segments, or  $V_L$  and  $J_L$  segments, and a constant region gene.

10. The transgenic mouse according to claim 1, comprising a repertoire of genes encoding rearranged or germline variable  $V_H$  or  $V_L$  domains of a heterologous species, modified for single chain antibody expression and optionally antigen binding by modification of variable-region framework and/or CDR residues and/or constant-region genes.
- 5
11. The transgenic mouse according to any preceding claim, in which any or all of the endogenous mouse heavy chain genes and/or light chain genes have been modified, functionally silenced and/or deleted.
- 10
12. The transgenic mouse according to any preceding claim, in which the single chain antibody is in monomeric or multimeric configuration.
13. The transgenic mouse according to any preceding claim, in which a repertoire of single chain antibodies are expressed.
- 15
14. The transgenic mouse according to any of claims 4 to 13, in which the heterologous heavy and/or light chain locus genes or the repertoire of genes undergo rearrangement and expression in mouse B cells.
- 20
15. The transgenic mouse according to any of claims 4 to 14, in which the heterologous species is mammalian.
16. The transgenic mouse according to claim 15, in which the heterologous species is noncamelid, for example human.
- 25
17. A method for the production of a transgenic mouse capable of expressing a single chain antibody having a heavy chain or a heavy chain linked to a light chain, comprising the steps of inserting immunoglobulin heavy or light chain locus genes of a heterologous species into the mouse, allowing expression of the genes to form the single chain antibody which is expressed either by extracellular display or by secretion or both.
- 30

18. A single chain antibody produced by the transgenic mouse as defined in any of claims 1 to 16.
19. The single chain antibody of claim 18, in which the single chain antibody is in the  
5 form of a monomer or multimers in which identical chains are associated.
20. The single chain antibody of claim 18, in which the antibody is in dimeric or multimeric form such that variable domains of the antibody bind antigen independently.
- 10 21. A monoclonal or polyclonal heavy chain only antibody, or a heavy-light chain chimeric antibody, which has a structure including a single domain antigen-combining V<sub>H</sub> or V<sub>L</sub> region and which is made upon immunisation of a mouse as defined in any of claims 1 to 16.
- 15 22. A method for producing the antibody of any of claims 18 to 21, comprising the step of immunising the mouse as defined in any of claims 1 to 16 with an antigen to elicit an immune response, the immune response comprising antigen-specific antibody production.
- 20 23. An antibody display library derived from the transgenic mouse as defined in any of claims 1 to 16, in which the display library comprises immunoglobulin heavy and/or light chain genes which are transcribed and translated *in vitro* to encode a population of single chain antibodies.
- 25 24. The display library of claim 23, wherein the library comprises lymphocyte DNA isolated from a mouse as defined in any of claims 1 to 16.
25. A method for the production of the display library as defined in either of claim 23 or claim 24, comprising the step of introducing the immunoglobulin heavy and/or light  
30 chain genes into a bacterial, yeast, phage or ribosome display system.
26. An isolated non-camelid immunoglobulin locus comprising heavy chain genes

modified to encode a single chain antibody capable of being expressed *in vivo*.

27. The locus of claim 26, further comprising light chain genes.

5 28. The locus of claim 27, in which the heavy and light chain genes comprise variable genes which are modified at their  $V_H/V_L$  interface.

29. A hybridoma obtainable from a transgenic mouse according to any of claims 1 to 16 by fusion of a splenocyte from the transgenic mouse with a B-cell tumour line cell, and  
10 subsequent selection of single clones.

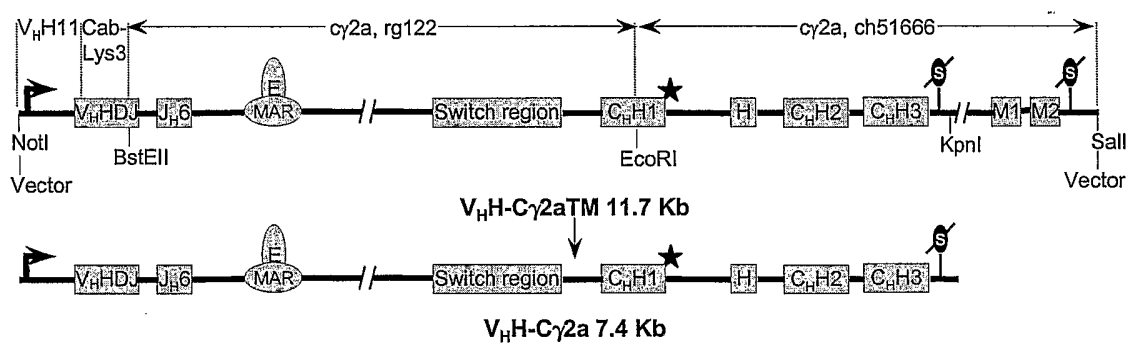
30. A single chain antibody obtainable from a hybridoma according to claim 29.

31. The single chain antibody according to claim 30, in which the single chain  
15 antibody is human.

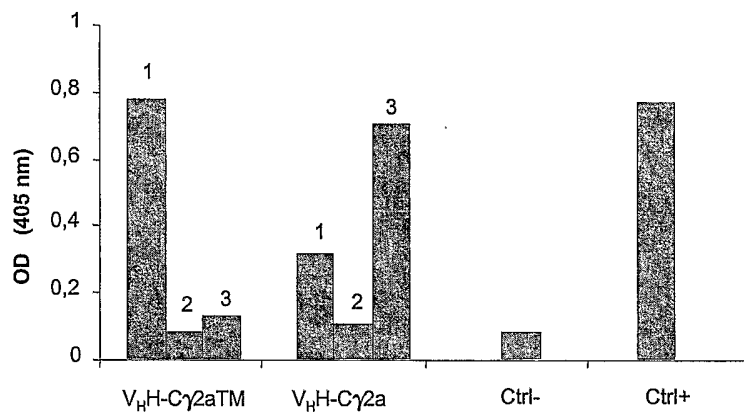
32. A method for producing a repertoire of single chain antibodies in a mouse.

33. The method of claim 32, in which the mouse is as defined in any of claims 1 to 16.  
20

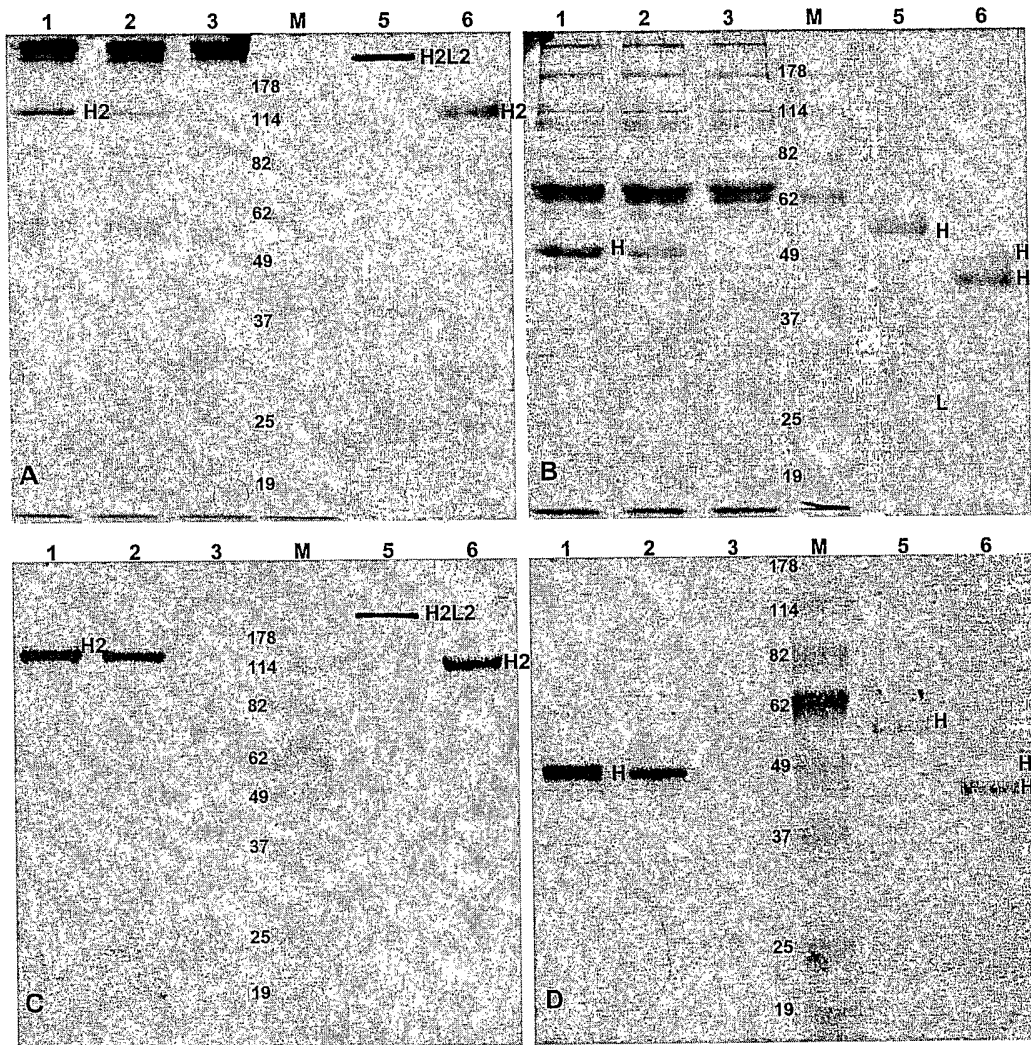
34. A repertoire of single chain antibodies produced according to either of claim 32 or claim 33.



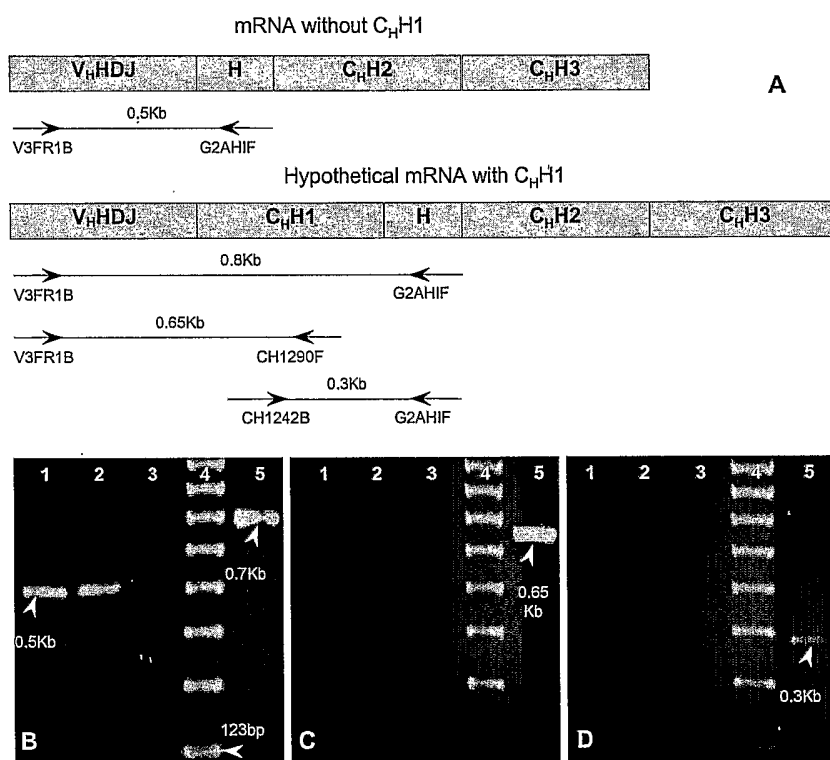
**Fig. 1**



**Fig. 2**

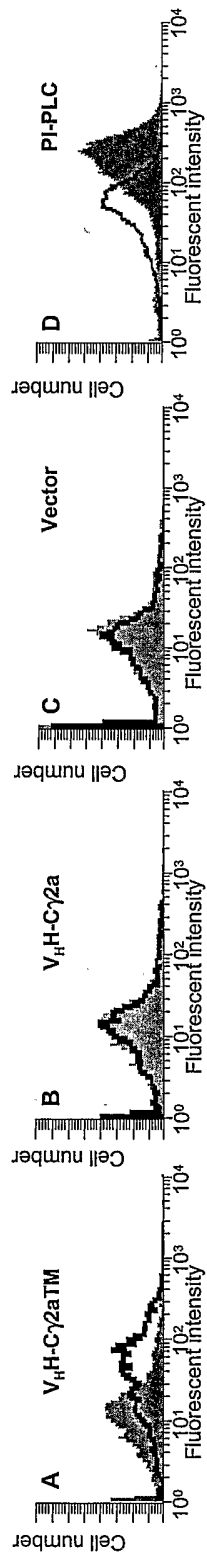


**Fig. 3**

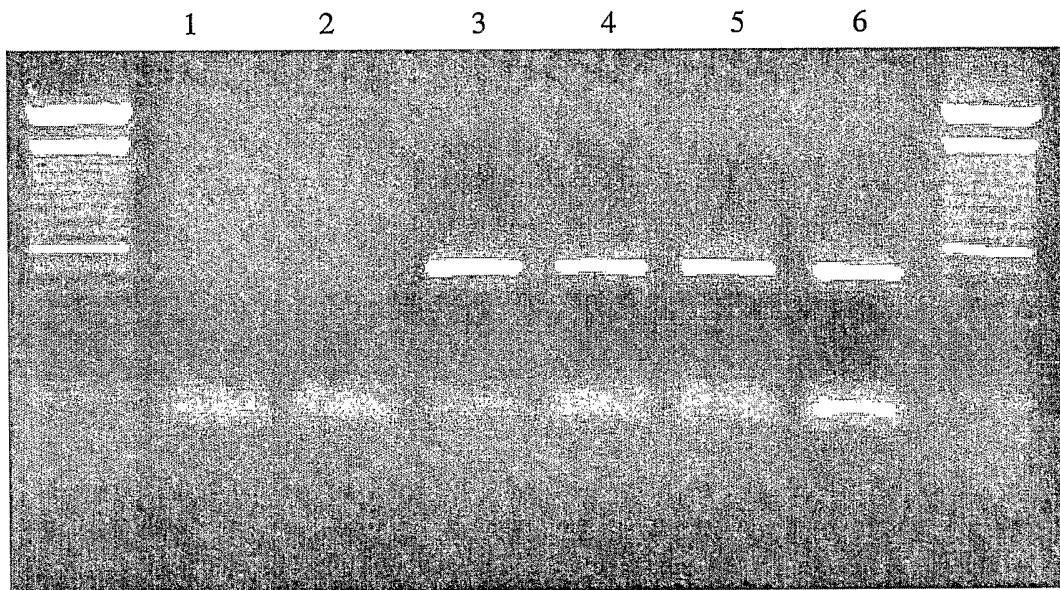


**Fig. 4**





**Fig. 5**



**Fig. 6**

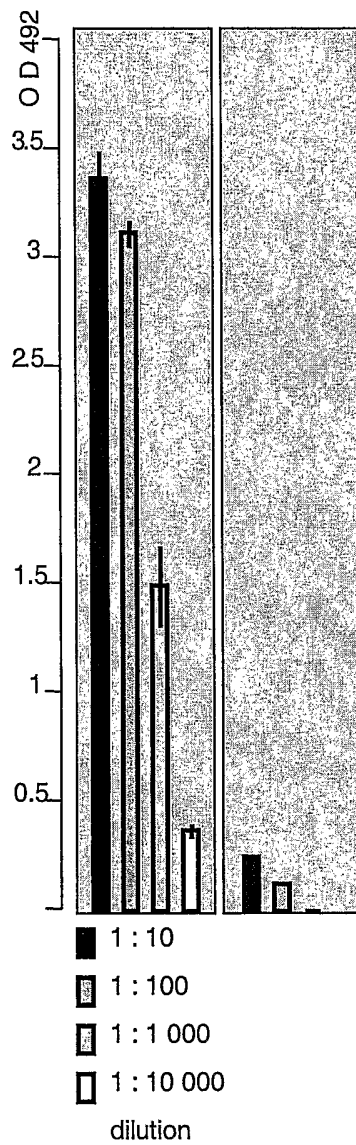


Fig. 7

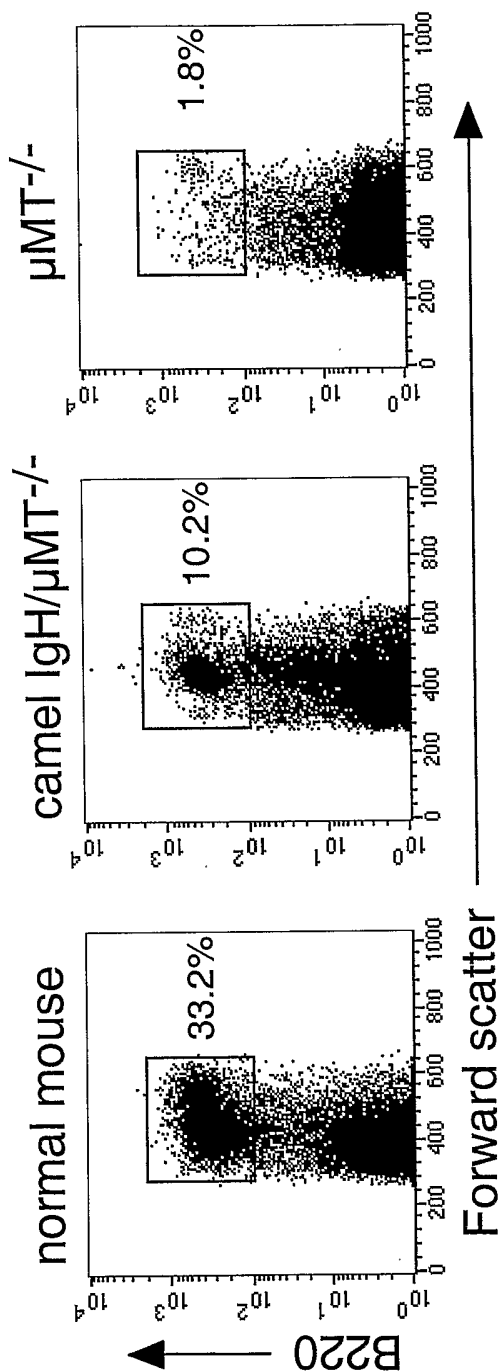


Fig. 8

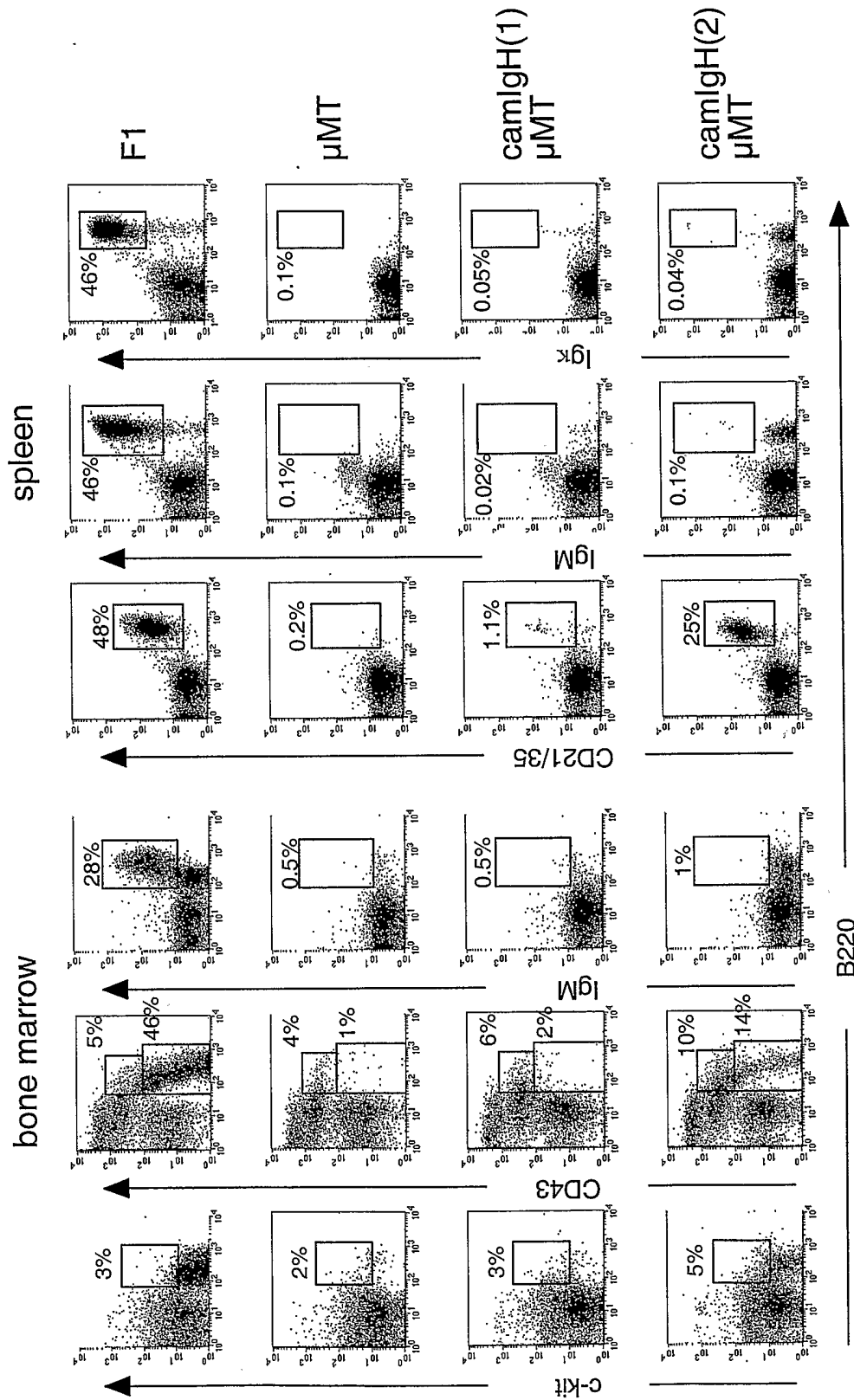
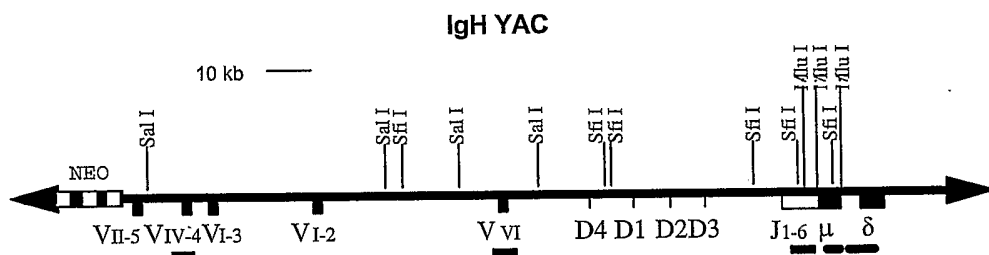
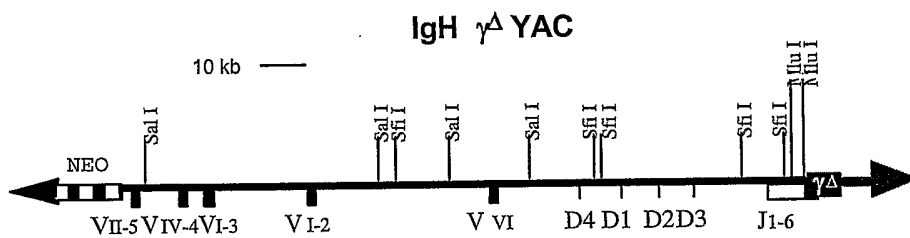


Fig. 9



**Fig. 10**



**Fig. 11**