

(19) World Intellectual Property Organization
International Bureau



(43) International Publication Date
26 January 2006 (26.01.2006)

PCT

(10) International Publication Number
WO 2006/009690 A1

- (51) International Patent Classification⁷: A61F 2/24
- (21) International Application Number: PCT/US2005/020947
- (22) International Filing Date: 15 June 2005 (15.06.2005)
- (25) Filing Language: English
- (26) Publication Language: English
- (30) Priority Data: 10/870,340 16 June 2004 (16.06.2004) US
- (71) Applicant (for all designated States except US): SADRA MEDICAL, INC. [US/US]; 1717 Dell Avenue, Campbell, CA 95008 (US).
- (72) Inventors; and
- (75) Inventors/Applicants (for US only): HAUG, Ulrich, R. [DE/US]; 2479 Twyla Court, Campbell, CA 95008 (US). VALENCIA, Hans, R. [PE/US]; 1609 La Vereda Road, Berkeley, CA 94709 (US). GESHLIDER, Robert, A. [US/US]; 233-27th Street, San Francisco, CA 94131 (US). SAUL, Tom [US/US]; 151 Madrid Avenue, El Granada,

CA 94018 (US). SALAHIEH, Amr [US/US]; 18729 Metler Court, Saratoga, CA 95070 (US). MOREJOHN, Dwight, P. [US/US]; 731 North Campus Way, Davis, CA 95616 (US). MICHLITSCH, Kenneth, J. [US/US]; 822 South M Street, Livermore, CA 94550 (US).

(74) Agents: SHAY, James, R. et al.; Wilson Sonsini Goodrich & Rosati, 650 Page Mill Road, Palo Alto, CA 94304-1050 (US).

(81) Designated States (unless otherwise indicated, for every kind of national protection available): AE, AG, AL, AM, AT, AU, AZ, BA, BB, BG, BR, BW, BY, BZ, CA, CH, CN, CO, CR, CU, CZ, DE, DK, DM, DZ, EC, EE, EG, ES, FI, GB, GD, GE, GH, GM, HR, HU, ID, IL, IN, IS, JP, KE, KG, KM, KP, KR, KZ, LC, LK, LR, LS, LT, LU, LV, MA, MD, MG, MK, MN, MW, MX, MZ, NA, NG, NI, NO, NZ, OM, PG, PH, PL, PT, RO, RU, SC, SD, SE, SG, SK, SL, SM, SY, TJ, TM, TN, TR, TT, TZ, UA, UG, US, UZ, VC, VN, YU, ZA, ZM, ZW.

(84) Designated States (unless otherwise indicated, for every kind of regional protection available): ARIPO (BW, GH,

[Continued on next page]

(54) Title: EVERTING HEART VALVE

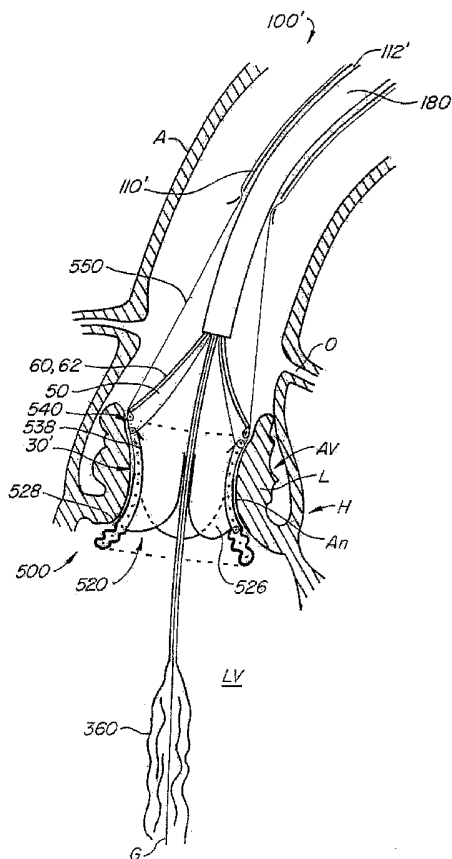

(57) Abstract: The present invention provides methods and apparatus for endovascularly replacing a patient's heart valve. The apparatus includes a replacement valve and an expandable anchor configured for endovascular delivery to a vicinity of the patient's heart valve. In some embodiments, the replacement valve is adapted to wrap about the anchor, for example, by everting during endovascular deployment. In some embodiments, the replacement valve is not connected to expandable portions of the anchor. In some embodiments, the anchor is configured for active foreshortening during endovascular deployment. In some embodiments, the anchor includes expandable lip and skirt regions for engaging the patient's heart valve during deployment. In some embodiments, the anchor comprises a braid fabricated from a single strand of wire. In some embodiments, the apparatus includes a lock configured to maintain anchor expansion. The invention also includes methods for endovascularly replacing a patient's heart valve. In some embodiments, the method includes the steps of endovascularly delivering a replacement valve and an expandable anchor to a vicinity of the heart valve, wrapping at least a portion of the replacement valve about the anchor, and expanding the anchor to a deployed configuration.

WO 2006/009690 A1



GM, KE, LS, MW, MZ, NA, SD, SL, SZ, TZ, UG, ZM, ZW), Eurasian (AM, AZ, BY, KG, KZ, MD, RU, TJ, TM), European (AT, BE, BG, CH, CY, CZ, DE, DK, EE, ES, FI, FR, GB, GR, HU, IE, IS, IT, LT, LU, MC, NL, PL, PT, RO, SE, SI, SK, TR), OAPI (BF, BJ, CF, CG, CI, CM, GA, GN, GQ, GW, ML, MR, NE, SN, TD, TG).

Published:

— with international search report

For two-letter codes and other abbreviations, refer to the "Guidance Notes on Codes and Abbreviations" appearing at the beginning of each regular issue of the PCT Gazette.

EVERTING HEART VALVE
BACKGROUND OF THE INVENTION

The present invention relates to methods and apparatus for endovascularly replacing a heart valve. More particularly, the present invention relates to methods and apparatus for endovascularly replacing a heart valve with a replacement valve and an expandable and retrievable anchor. The replacement valve preferably is not connected to the expandable anchor and may be wrapped about an end of the anchor, for example, by everting during endovascular deployment.

Heart valve surgery is used to repair or replace diseased heart valves. Valve surgery is an open-heart procedure conducted under general anesthesia. An incision is made through the patient's sternum (sternotomy), and the patient's heart is stopped while blood flow is rerouted through a heart-lung bypass machine.

Valve replacement may be indicated when there is a narrowing of the native heart valve, commonly referred to as stenosis, or when the native valve leaks or regurgitates. When replacing the valve, the native valve is excised and replaced with either a biologic or a mechanical valve. Mechanical valves require lifelong anticoagulant medication to prevent blood clot formation, and clicking of the valve often may be heard through the chest. Biologic tissue valves typically do not require such medication. Tissue valves may be obtained from cadavers or may be porcine or bovine, and are commonly attached to synthetic rings that are secured to the patient's heart.

Valve replacement surgery is a highly invasive operation with significant concomitant risk. Risks include bleeding, infection, stroke, heart attack, arrhythmia, renal failure, adverse reactions to the anesthesia medications, as well as sudden death. 2-5% of patients die during surgery.

Post-surgery, patients temporarily may be confused due to emboli and other factors associated with the heart-lung machine. The first 2-3 days following surgery are spent in an intensive care unit where heart functions can be closely monitored. The average hospital stay is between 1 to 2 weeks, with several more weeks to months required for complete recovery.

In recent years, advancements in minimally invasive surgery and interventional cardiology have encouraged some investigators to pursue percutaneous replacement of the aortic heart valve. See, e.g., U.S. Pat. No. 6,168,614. In many of these procedures, the replacement valve is deployed across the native diseased valve to permanently hold the valve open, thereby alleviating a need to excise the native valve and to position the replacement valve in place of the native valve.

In the endovascular aortic valve replacement procedure, accurate placement of aortic valves relative to coronary ostia and the mitral valve is critical. Standard self-expanding systems have very poor accuracy in deployment, however. Often the proximal end of the stent is not released from the delivery system until accurate placement is verified by fluoroscopy, and the stent typically jumps once released. It is therefore often impossible to know where the ends of the stent will be with respect to the native valve, the coronary ostia and the mitral valve.

Also, visualization of the way the new valve is functioning prior to final deployment is very desirable. Visualization prior to final and irreversible deployment cannot be done with standard self-expanding systems, however, and the replacement valve is often not fully functional before final deployment.

Another drawback of prior art self-expanding replacement heart valve systems is their lack of radial strength. In order for self-expanding systems to be easily delivered through a delivery sheath, the metal needs to

flex and bend inside the delivery catheter without being plastically deformed. In arterial stents, this is not a challenge, and there are many commercial arterial stent systems that apply adequate radial force against the vessel wall and yet can collapse to a small enough of a diameter to fit inside a delivery catheter without plastic deformation. However when the stent has a valve fastened inside it, as is the case in aortic valve replacement, the anchoring of the stent to vessel walls is significantly challenged during diastole. The force to hold back arterial pressure and prevent blood from going back inside the ventricle during diastole will be directly transferred to the stent/vessel wall interface. Therefore, the amount of radial force required to keep the self-expanding stent/valve in contact with the vessel wall and not sliding will be much higher than in stents that do not have valves inside of them. Moreover, a self-expanding stent without sufficient radial force will end up dilating and contracting with each heartbeat, thereby distorting the valve, affecting its function and possibly migrating and dislodging completely. Simply increasing strut thickness of the self-expanding stent is not a practical solution as it runs the risk of larger profile and/or plastic deformation of the self-expanding stent.

In view of drawbacks associated with previously known techniques for endovascularly replacing a heart valve, it would be desirable to provide methods and apparatus that overcome those drawbacks.

15

SUMMARY OF THE INVENTION

One aspect of the present invention provides apparatus for endovascularly replacing a patient's heart valve, the apparatus including: a replacement valve; and an expandable anchor, wherein the replacement valve and expandable anchor are configured for endovascular delivery to the vicinity of the heart valve, and wherein at least a portion of the replacement valve is configured to evert about the anchor during endovascular deployment.

20

Another aspect of the invention provides a method for endovascularly replacing a patient's heart valve. In some embodiments the method includes the steps of: endovascularly delivering a replacement valve and an expandable anchor to a vicinity of the heart valve; everting at least a portion of the replacement valve about the anchor; and expanding the anchor to a deployed configuration.

25

Yet another aspect of the invention provides apparatus for endovascularly replacing a patient's heart valve including: an anchor comprising a lip region and a skirt region; and a replacement valve, wherein at least a portion of the replacement valve is configured to evert about the anchor during endovascular deployment, and wherein the lip region and skirt region are configured for percutaneous expansion to engage the patient's heart valve.

30

Still another aspect of the present invention provides a method for endovascularly replacing a patient's heart valve, the method including: endovascularly delivering a replacement valve and an expandable anchor to a vicinity of the heart valve, endovascularly wrapping at least a portion of the replacement valve about the anchor, and expanding the anchor to a deployed configuration.

35

Another aspect of the present invention provides apparatus for endovascularly replacing a patient's heart valve, the apparatus including: a replacement valve, and an expandable anchor, wherein the replacement valve and the anchor are configured for endovascular delivery to a vicinity of the patient's heart valve, and wherein at least a portion of the replacement valve is wrapped about an end of the anchor in a deployed configuration.

INCORPORATION BY REFERENCE

All publications and patent applications mentioned in this specification are herein incorporated by reference to the same extent as if each individual publication or patent application was specifically and individually indicated to be incorporated by reference.

5

BRIEF DESCRIPTION OF THE DRAWINGS

The novel features of the invention are set forth with particularity in the appended claims. A better understanding of the features and advantages of the present invention will be obtained by reference to the following detailed description that sets forth illustrative embodiments, in which the principles of the invention are utilized, and the accompanying drawings of which:

10

Figures 1A-B are elevational views of a replacement heart valve and anchor according to one embodiment of the invention.

Figures 2A-B are sectional views of the anchor and valve of Figures 1.

Figures 3A-B show delivery and deployment of a replacement heart valve and anchor, such as the anchor and valve of Figures 1 and 2.

15

Figures 4A-F also show delivery and deployment of a replacement heart valve and anchor, such as the anchor and valve of Figures 1 and 2.

Figures 5A-F show the use of a replacement heart valve and anchor to replace an aortic valve.

Figures 6A-F show the use of a replacement heart valve and anchor with a positive registration feature to replace an aortic valve.

20

Figure 7 shows the use of a replacement heart valve and anchor with an alternative positive registration feature to replace an aortic valve.

Figures 8A-C show another embodiment of a replacement heart valve and anchor according to the invention.

Figures 9A-H show delivery and deployment of the replacement heart valve and anchor of Figures 8.

25

Figure 10 is a cross-sectional drawing of the delivery system used with the method and apparatus of Figures 8 and 9.

Figures 11A-C show alternative locks for use with replacement heart valves and anchors of this invention.

30

Figures 12A-C show a vessel wall engaging lock for use with replacement heart valves and anchors of this invention.

Figure 13 demonstrates paravalvular leaking around a replacement heart valve and anchor.

Figure 14 shows a seal for use with a replacement heart valve and anchor of this invention.

Figures 15A-E show alternative arrangements of seals on a replacement heart valve and anchor.

Figures 16A-C show alternative seal designs for use with replacement heart valves and anchors.

35

Figures 17 show an alternative anchor lock embodiment in an unlocked configuration.

Figures 18A-B show the anchor lock of Figure 17 in a locked configuration.

Figure 19 shows an alternative anchor deployment tool attachment and release mechanism for use with the invention.

Figure 20 shows the attachment and release mechanism of Figure 19 in the process of being released.

40

Figure 21 shows the attachment and release mechanism of Figures 19 and 20 in a released condition.

Figure 22 shows an alternative embodiment of a replacement heart valve and anchor and a deployment tool according to the invention in an undeployed configuration.

Figure 23 shows the replacement heart valve and anchor of Figure 22 in a partially deployed configuration.

5 Figure 24 shows the replacement heart valve and anchor of Figures 22 and 23 in a more fully deployed configuration but with the deployment tool still attached.

Figure 25 shows yet another embodiment of the delivery and deployment apparatus of the invention in use with a replacement heart valve and anchor.

10 Figure 26 shows the delivery and deployment apparatus of Figure 25 in the process of deploying a replacement heart valve and anchor.

Figure 27 shows an embodiment of the invention employing seals at the interface of the replacement heart valve and anchor and the patient's tissue.

Figure 28 is a longitudinal cross-sectional view of the seal shown in Figure 27 in compressed form.

Figure 29 is a transverse cross-sectional view of the seal shown in Figure 28.

15 Figure 30 is a longitudinal cross-sectional view of the seal shown in Figure 27 in expanded form.

Figure 31 is a transverse cross-sectional view of the seal shown in Figure 30.

Figure 32 shows yet another embodiment of the replacement heart valve and anchor of this invention in an undeployed configuration.

Figure 33 shows the replacement heart valve and anchor of Figure 32 in a deployed configuration.

20 Figure 34 shows the replacement heart valve and anchor of Figures 32 and 33 deployed in a patient's heart valve.

Figures 35A-H show yet another embodiment of a replacement heart valve, anchor and deployment system according to this invention.

Figures 36A-E show more detail of the anchor of the embodiment shown in Figures 35A-H.

25 Figures 37A-B show other embodiments of the replacement heart valve and anchor of the invention.

Figures 38A-C illustrate a method for endovascularly replacing a patient's diseased heart valve.

30 Figures 39A-G are side views, partially in section, as well as an isometric view, illustrating a method for endovascularly replacing a patient's diseased heart valve with an embodiment of the present invention comprising a replacement valve that is not connected to the expandable anchor, the replacement valve wrapped about the anchor, illustratively by everting during deployment.

Figures 40A-D are side views, partially in section, illustrating a method for endovascularly replacing a patient's diseased heart valve with another everting embodiment of the present invention.

35 Figures 41A-E are side views, partially in section, illustrating a method for endovascularly replacing a patient's diseased heart valve with yet another everting embodiment of the present invention, wherein the replacement valve and the anchor are telescoped relative to one another during endovascular delivery.

Figures 42A-B are side-sectional views of alternative everting apparatus comprising everting valve leaflets.

Figures 43A-B, are side-sectional views of further alternative everting apparatus comprising a locking mechanism coupled to the everting segment.

Figures 44A-B are side-sectional views of telescoping embodiments of the present invention comprising U-shaped valve frames.

DETAILED DESCRIPTION OF THE INVENTION

While preferred embodiments of the present invention have been shown and described herein, it will be obvious to those skilled in the art that such embodiments are provided by way of example only. Numerous variations, changes, and substitutions will now occur to those skilled in the art without departing from the invention. It should be understood that various alternatives to the embodiments of the invention described herein may be employed in practicing the invention. For example, for the two-part locking mechanisms described hereinafter, it will be apparent that the locations of the male and female elements may be reversed. It is intended that the following claims define the scope of the invention and that methods and structures within the scope of these claims and their equivalents be covered thereby.

With reference now to Figures 1-4, a first embodiment of replacement heart valve apparatus in accordance with the present invention is described, including a method of actively foreshortening and expanding the apparatus from a delivery configuration and to a deployed configuration. Apparatus 10 comprises replacement valve 20 disposed within and coupled to anchor 30. Figures 1 schematically illustrate individual cells of anchor 30 of apparatus 10, and should be viewed as if the cylindrical anchor has been cut open and laid flat. Figures 2 schematically illustrate a detail portion of apparatus 10 in side-section.

Anchor 30 has a lip region 32, a skirt region 34 and a body region 36. First, second and third posts 38a, 38b and 38c, respectively, are coupled to skirt region 34 and extend within lumen 31 of anchor 30. Posts 38 preferably are spaced 120° apart from one another about the circumference of anchor 30.

Anchor 30 preferably is fabricated by using self-expanding patterns (laser cut or chemically milled), braids and materials, such as a stainless steel, nickel-titanium ("Nitinol") or cobalt chromium, but alternatively may be fabricated using balloon-expandable patterns where the anchor is designed to plastically deform to its final shape by means of balloon expansion. Replacement valve 20 is preferably made from biologic tissues, e.g. porcine valve leaflets or bovine or equine pericardium tissues or human cadaver tissue. Alternatively, it can be made from tissue engineered materials (such as extracellular matrix material from Small Intestinal Submucosa (SIS)) or may be prosthetic and made from an elastomeric polymer or silicone, Nitinol or stainless steel mesh or pattern (sputtered, chemically milled or laser cut). The leaflet may also be made of a composite of the elastomeric or silicone materials and metal alloys or other fibers such Kevlar or carbon. Annular base 22 of replacement valve 20 preferably is coupled to skirt region 34 of anchor 30, while commissures 24 of replacement valve leaflets 26 are coupled to and supported by posts 38.

Anchor 30 may be actuated using external non-hydraulic or non-pneumatic force to actively foreshorten in order to increase its radial strength. As shown below, the proximal and distal end regions of anchor 30 may be actuated independently. The anchor and valve may be placed and expanded in order to visualize their location with respect to the native valve and other anatomical features and to visualize operation of the valve. The anchor and valve may thereafter be repositioned and even retrieved into the delivery sheath or catheter. The apparatus may be delivered to the vicinity of the patient's aortic valve in a retrograde approach in a catheter having a diameter no more than 23 french, preferably no more than 21 french, more preferably no more than 19 french, or more preferably no more than 17 french. Upon deployment the anchor and replacement valve capture the native valve leaflets and positively lock to maintain configuration and position.

A deployment tool is used to actuate, reposition, lock and/or retrieve anchor 30. In order to avoid delivery of anchor 30 on a balloon for balloon expansion, a non-hydraulic or non-pneumatic anchor actuator is used. In this embodiment, the actuator is a deployment tool that includes distal region control wires 50, control rods or tubes 60 and proximal region control wires 62. Locks 40 include posts or arms 38 preferably with male interlocking elements 44 extending from skirt region 34 and mating female interlocking elements 42 in lip region 32. Male interlocking elements 44 have eyelets 45. Control wires 50 pass from a delivery system for apparatus 10 through female interlocking elements 42, through eyelets 45 of male interlocking elements 44, and back through female interlocking elements 42, such that a double strand of wire 50 passes through each female interlocking element 42 for manipulation by a medical practitioner external to the patient to actuate and control the anchor by changing the anchor's shape. Control wires 50 may comprise, for example, strands of suture.

Tubes 60 are reversibly coupled to apparatus 10 and may be used in conjunction with wires 50 to actuate anchor 30, e.g., to foreshorten and lock apparatus 10 in the fully deployed configuration. Tubes 60 also facilitate repositioning and retrieval of apparatus 10, as described hereinafter. For example, anchor 30 may be foreshortened and radially expanded by applying a distally directed force on tubes 60 while proximally retracting wires 50. As seen in Figures 3, control wires 62 pass through interior lumens 61 of tubes 60. This ensures that tubes 60 are aligned properly with apparatus 10 during deployment and foreshortening. Control wires 62 can also actuate anchor 30; proximally directed forces on control wires 62 contacts the proximal lip region 32 of anchor 30. Wires 62 also act to couple and decouple tubes 60 from apparatus 10. Wires 62 may comprise, for example, strands of suture.

Figures 1A and 2A illustrate anchor 30 in a delivery configuration or in a partially deployed configuration (e.g., after dynamic self-expansion from a constrained delivery configuration within a delivery sheath). Anchor 30 has a relatively long length and a relatively small width in the delivery or partially deployed configuration, as compared to the foreshortened and fully deployed configuration of Figures 1B and 2B.

In Figures 1A and 2A, replacement valve 20 is collapsed within lumen 31 of anchor 30. Retraction of wires 50 relative to tubes 60 foreshortens anchor 30, which increases the anchor's width while decreasing its length. Such foreshortening also properly seats replacement valve 20 within lumen 31 of anchor 30. Imposed foreshortening will enhance radial force applied by apparatus 10 to surrounding tissue over at least a portion of anchor 30. In some embodiments, the anchor is capable of exerting an outward radial force on surrounding tissue to engage the tissue in such way to prevent migration of anchor. This outward radial force is preferably greater than 2 psi, more preferably greater than 4 psi, more preferably greater than 6 psi, more preferably greater than 8 psi, more preferably greater than 10 psi, more preferably greater than 20 psi, or more preferably greater than 30 psi. Enhanced radial force of the anchor is also important for enhanced crush resistance of the anchor against the surrounding tissue due to the healing response (fibrosis and contraction of annulus over a longer period of time) or to dynamic changes of pressure and flow at each heart beat. In an alternative embodiment, the anchor pattern or braid is designed to have gaps or areas where the native tissue is allowed to protrude through the anchor slightly (not shown) and, as the foreshortening is applied, the tissue and anchor become intertwined and immobilized. This feature would provide additional means to prevent anchor migration and enhance long-term stability of the device.

Deployment of apparatus 10 is fully reversible until lock 40 has been locked via mating of male interlocking elements 44 with female interlocking elements 42. Deployment is then completed by decoupling

tubes 60 from lip section 32 of anchor 30 by retracting one end of each wire 62 relative to the other end of the wire, and by retracting one end of each wire 50 relative to the other end of the wire until each wire has been removed from eyelet 45 of its corresponding male interlocking element 44.

As best seen in Figure 2B, body region 36 of anchor 30 optionally may comprise barb elements 37 that protrude from anchor 30 in the fully deployed configuration, for example, for engagement of a patient's native valve leaflets and to preclude migration of the apparatus.

With reference now to Figures 3, a delivery and deployment system for a self-expanding embodiment of apparatus 10 including a sheath 110 having a lumen 112. Self-expanding anchor 30 is collapsible to a delivery configuration within lumen 112 of sheath 110, such that apparatus 10 may be delivered via delivery system 100. As seen in Figure 3A, apparatus 10 may be deployed from lumen 112 by retracting sheath 110 relative to apparatus 10, control wires 50 and tubes 60, which causes anchor 30 to dynamically self-expand to a partially deployed configuration. Control wires 50 then are retracted relative to apparatus 10 and tubes 60 to impose foreshortening upon anchor 30, as seen in Figure 3B.

During foreshortening, tubes 60 push against lip region 32 of anchor 30, while wires 50 pull on posts 38 of the anchor. Wires 62 may be retracted along with wires 50 to enhance the distally directed pushing force applied by tubes 60 to lip region 32. Continued retraction of wires 50 relative to tubes 60 would lock locks 40 and fully deploy apparatus 10 with replacement valve 20 properly seated within anchor 30, as in Figures 1B and 2B. Apparatus 10 comprises enhanced radial strength in the fully deployed configuration as compared to the partially deployed configuration of Figure 3A. Once apparatus 10 has been fully deployed, wires 50 and 62 may be removed from apparatus 10, thereby separating delivery system 100 and tubes 60 from the apparatus.

Deployment of apparatus 10 is fully reversible until locks 40 have been actuated. For example, just prior to locking the position of the anchor and valve and the operation of the valve may be observed under fluoroscopy. If the position needs to be changed, by alternately relaxing and reapplying the proximally directed forces exerted by control wires 50 and/or control wires 62 and the distally directed forces exerted by tubes 60, expansion and contraction of the lip and skirt regions of anchor 30 may be independently controlled so that the anchor and valve can be moved to, e.g., avoid blocking the coronary ostia or impinging on the mitral valve. Apparatus 10 may also be completely retrieved within lumen 112 of sheath 110 by simultaneously proximally retracting wires 50 and tubes 60/wires 62 relative to sheath 110. Apparatus 10 then may be removed from the patient or repositioned for subsequent redeployment.

Referring now to Figures 4, step-by-step deployment of apparatus 10 via delivery system 100 is described. In Figure 4A, sheath 110 is retracted relative to apparatus 10, wires 50 and tubes 60, thereby causing self-expandable anchor 30 to dynamically self-expand apparatus 10 from the collapsed delivery configuration within lumen 112 of sheath 110 to the partially deployed configuration. Apparatus 10 may then be dynamically repositioned via tubes 60 to properly orient the apparatus, e.g. relative to a patient's native valve leaflets.

In Figure 4B, control wires 50 are retracted while tubes 60 are advanced, thereby urging lip region 32 of anchor 30 in a distal direction while urging posts 38 of the anchor in a proximal direction. This foreshortens apparatus 10, as seen in Figure 4C. Deployment of apparatus 10 is fully reversible even after foreshortening has been initiated and has advanced to the point illustrated in Figure 4C.

In Figure 4D, continued foreshortening causes male interlocking elements 44 of locks 40 to engage female interlocking elements 42. The male elements mate with the female elements, thereby locking apparatus

10 in the foreshortened configuration, as seen in Figure 4E. Wires 50 are then pulled through eyelets 45 of male elements 44 to remove the wires from apparatus 10, and wires 62 are pulled through the proximal end of anchor 30 to uncouple tubes 60 from the apparatus, thereby separating delivery system 100 from apparatus 10. Fully deployed apparatus 10 is shown in Figure 4F.

5 Referring to Figures 5, a method of endovascularly replacing a patient's diseased aortic valve with apparatus 10 and delivery system 100 is described. As seen in Figure 5A, sheath 110 of delivery system 100, having apparatus 10 disposed therein, is endovascularly advanced over guide wire G, preferably in a retrograde fashion (although an antegrade or hybrid approach alternatively may be used), through a patient's aorta A to the patient's diseased aortic valve AV. A nosecone 102 precedes sheath 110 in a known manner. In Figure 5B,
10 sheath 110 is positioned such that its distal region is disposed within left ventricle LV of the patient's heart H.

Apparatus 10 is deployed from lumen 112 of sheath 110, for example, under fluoroscopic guidance, such that anchor 30 of apparatus 10 dynamically self-expands to a partially deployed configuration, as in Figure 5C. Advantageously, apparatus 10 may be retracted within lumen 112 of sheath 110 via wires 50 - even after
15 anchor 30 has dynamically expanded to the partially deployed configuration, for example, to abort the procedure or to reposition apparatus 10 or delivery system 100. As yet another advantage, apparatus 10 may be dynamically repositioned, e.g. via sheath 110 and/or tubes 60, in order to properly align the apparatus relative to anatomical landmarks, such as the patient's coronary ostia or the patient's native valve leaflets L. When properly aligned, skirt region 34 of anchor 30 preferably is disposed distal of the leaflets, while body region 36 is disposed across the leaflets and lip region 32 is disposed proximal of the leaflets.

20 Once properly aligned, wires 50 are retracted relative to tubes 60 to impose foreshortening upon anchor 30 and expand apparatus 10 to the fully deployed configuration, as in Figure 5D. Foreshortening increases the radial strength of anchor 30 to ensure prolonged patency of valve annulus An, as well as to provide a better seal for apparatus 10 that reduces paravalvular regurgitation. As seen in Figure 5E, locks 40 maintain imposed foreshortening. Replacement valve 20 is properly seated within anchor 30, and normal blood flow between left
25 ventricle LV and aorta A is thereafter regulated by apparatus 10. Deployment of apparatus 10 advantageously is fully reversible until locks 40 have been actuated.

As seen in Figure 5F, wires 50 are pulled from eyelets 45 of male elements 44 of locks 40, tubes 60 are decoupled from anchor 30, e.g. via wires 62, and delivery system 100 is removed from the patient, thereby completing deployment of apparatus 10. Optional barb elements 37 engage the patient's native valve leaflets,
30 e.g. to preclude migration of the apparatus and/or reduce paravalvular regurgitation.

With reference now to Figures 6, a method of endovascularly replacing a patient's diseased aortic valve with apparatus 10 is provided, wherein proper positioning of the apparatus is ensured via positive registration of a modified delivery system to the patient's native valve leaflets. In Figure 6A, modified delivery system 100' delivers apparatus 10 to diseased aortic valve AV within sheath 110. As seen in Figures 6B and 6C, apparatus
35 10 is deployed from lumen 112 of sheath 110, for example, under fluoroscopic guidance, such that anchor 30 of apparatus 10 dynamically self-expands to a partially deployed configuration. As when deployed via delivery system 100, deployment of apparatus 10 via delivery system 100' is fully reversible until locks 40 have been actuated.

40 Delivery system 100' comprises leaflet engagement element 120, which preferably self-expands along with anchor 30. Engagement element 120 is disposed between tubes 60 of delivery system 100' and lip region

32 of anchor 30. Element 120 releasably engages the anchor. As seen in Figure 6C, the element is initially deployed proximal of the patient's native valve leaflets L. Apparatus 10 and element 120 then may be advanced/dynamically repositioned until the engagement element positively registers against the leaflets, thereby ensuring proper positioning of apparatus 10. Also, delivery system 100' includes filter structure 61A (e.g., filter membrane or braid) as part of push tubes 60 to act as an embolic protection element. Emboli can be generated during manipulation and placement of anchor, from either diseased native leaflet or surrounding aortic tissue, and can cause blockage. Arrows 61B in Figure 6E show blood flow through filter structure 61A where blood is allowed to flow but emboli is trapped in the delivery system and removed with it at the end of the procedure.

Alternatively, foreshortening may be imposed upon anchor 30 while element 120 is disposed proximal of the leaflets, as in Figure 6D. Upon positive registration of element 120 against leaflets L, element 120 precludes further distal migration of apparatus 10 during additional foreshortening, thereby reducing a risk of improperly positioning the apparatus. Figure 6E details engagement of element 120 against the native leaflets. As seen in Figure 6F, once apparatus 10 is fully deployed, element 120, wires 50 and tubes 60 are decoupled from the apparatus, and delivery system 100' is removed from the patient, thereby completing the procedure.

With reference to Figure 7, an alternative embodiment of the apparatus of Figures 6 is described, wherein leaflet engagement element 120 is coupled to anchor 30 of apparatus 10', rather than to delivery system 100. Engagement element 120 remains implanted in the patient post-deployment of apparatus 10'. Leaflets L are sandwiched between lip region 32 of anchor 30 and element 120 in the fully deployed configuration. In this manner, element 120 positively registers apparatus 10' relative to the leaflets and precludes distal migration of the apparatus over time.

Referring now to Figures 8, an alternative delivery system adapted for use with a balloon expandable embodiment of the present invention is described. In Figure 8A, apparatus 10'' comprises anchor 30' that may be fabricated from balloon-expandable materials. Delivery system 100'' comprises inflatable member 130 disposed in a deflated configuration within lumen 31 of anchor 30'. In Figure 8B, optional outer sheath 110 is retracted, and inflatable member 130 is inflated to expand anchor 30' to the fully deployed configuration. As inflatable member 130 is being deflated, as in earlier embodiments, wires 50 and 62 and tubes 60 may be used to assist deployment of anchor 30' and actuation of locks 40, as well as to provide reversibility and retrievability of apparatus 10'' prior to actuation of locks 40. Next, wires 50 and 62 and tubes 60 are removed from apparatus 10'', and delivery system 100'' is removed, as seen in Figure 8C.

As an alternative delivery method, anchor 30' may be partially deployed via partial expansion of inflatable member 130. The inflatable member would then be advanced within replacement valve 20 prior to inflation of inflatable member 130 and full deployment of apparatus 10''. Inflation pressures used will range from about 3 to 6 atm, or more preferably from about 4 to 5 atm, though higher and lower atm pressures may also be used (e.g., greater than 3 atm, more preferably greater than 4 atm, more preferably greater than 5 atm, or more preferably greater than 6 atm). Advantageously, separation of inflatable member 130 from replacement valve 20, until partial deployment of apparatus 10'' at a treatment site, is expected to reduce a delivery profile of the apparatus, as compared to previously known apparatus. This profile reduction may facilitate retrograde delivery and deployment of apparatus 10'', even when anchor 30' is balloon-expandable.

Although anchor 30' has illustratively been described as fabricated from balloon-expandable materials, it should be understood that anchor 30' alternatively may be fabricated from self-expanding materials whose expansion optionally may be balloon-assisted. In such a configuration, anchor 30' would expand to a partially deployed configuration upon removal of outer sheath 110. If required, inflatable member 130 then would be advanced within replacement valve 20 prior to inflation. Inflatable member 130 would assist full deployment of apparatus 10'', for example, when the radial force required to overcome resistance from impinging tissue were too great to be overcome simply by manipulation of wires 50 and tubes 60. Advantageously, optional placement of inflatable member 130 within replacement valve 20, only after dynamic self-expansion of apparatus 10'' to the partially deployed configuration at a treatment site, is expected to reduce a delivery profile of the apparatus, as compared to previously known apparatus. This reduction may facilitate retrograde delivery and deployment of apparatus 10''.

With reference to Figures 9 and 10, methods and apparatus for a balloon-assisted embodiment of the present invention are described in greater detail. Figures 9 and 10 illustratively show apparatus 10' of Figures 7 used in combination with delivery system 100'' of Figures 8. Figure 10 illustrates a sectional view of delivery system 100''. Inner shaft 132 of inflatable member 130 preferably is about 4 Fr in diameter, and comprises lumen 133 configured for passage of guidewire G, having a diameter of about 0.035'', therethrough. Push tubes 60 and pull wires 50 pass through guidetube 140, which preferably has a diameter of about 15 Fr or smaller. Guide tube 140 is disposed within lumen 112 of outer sheath 110, which preferably has a diameter of about 17 Fr or smaller.

In Figure 9A, apparatus 10' is delivered to diseased aortic valve AV within lumen 112 of sheath 110. In Figure 9B, sheath 110 is retracted relative to apparatus 10' to dynamically self-expand the apparatus to the partially deployed configuration. Also retracted and removed is nosecone 102, which is attached to a pre-slit lumen (not shown) that facilitates its removal prior to loading and advancing of a regular angioplasty balloon catheter over guidewire and inside delivery system 110.

In Figure 9C, pull wires 50 and push tubes 60 are manipulated from external to the patient to foreshorten anchor 30 and sufficiently expand lumen 31 of the anchor to facilitate advancement of inflatable member 130 within replacement valve 20. Also shown is the tip of an angioplasty catheter 130 being advanced through delivery system 110.

The angioplasty balloon catheter or inflatable member 130 then is advanced within the replacement valve, as in Figure 9D, and additional foreshortening is imposed upon anchor 30 to actuate locks 40, as in Figure 9E. The inflatable member is inflated to further displace the patient's native valve leaflets L and ensure adequate blood flow through, and long-term patency of, replacement valve 20, as in Figure 9F. Inflatable member 130 then is deflated and removed from the patient, as in Figure 9G. A different size angioplasty balloon catheter could be used repeat the same step if deemed necessary by the user. Push tubes 60 optionally may be used to further set leaflet engagement element 120, or optional barbs B along posts 38, more deeply within leaflets L, as in Figure 9H. Then, delivery system 100'' is removed from the patient, thereby completing percutaneous heart valve replacement.

As will be apparent to those of skill in the art, the order of imposed foreshortening and balloon expansion described in Figures 9 and 10 is only provided for the sake of illustration. The actual order may vary according to the needs of a given patient and/or the preferences of a given medical practitioner. Furthermore,

balloon-assist may not be required in all instances, and the inflatable member may act merely as a safety precaution employed selectively in challenging clinical cases.

Referring now to Figures 11, alternative locks for use with apparatus of the present invention are described. In Figure 11A, lock 40' comprises male interlocking element 44 as described previously. However, female interlocking element 42' illustratively comprises a triangular shape, as compared to the round shape of interlocking element 42 described previously. The triangular shape of female interlocking element 42' may facilitate mating of male interlocking element 44 with the female interlocking element without necessitating deformation of the male interlocking element.

In Figure 11B, lock 40'' comprises alternative male interlocking element 44' having multiple in-line arrowheads 46 along posts 38. Each arrowhead comprises resiliently deformable appendages 48 to facilitate passage through female interlocking element 42. Appendages 48 optionally comprise eyelets 49, such that control wire 50 or a secondary wire may pass therethrough to constrain the appendages in the deformed configuration. To actuate lock 40'', one or more arrowheads 46 of male interlocking element 44' are drawn through female interlocking element 42, and the wire is removed from eyelets 49, thereby causing appendages 48 to resiliently expand and actuate lock 40''.

Advantageously, providing multiple arrowheads 46 along posts 38 yields a ratchet that facilitates *in-vivo* determination of a degree of foreshortening imposed upon apparatus of the present invention. Furthermore, optionally constraining appendages 48 of arrowheads 46 via eyelets 49 prevents actuation of lock 40'' (and thus deployment of apparatus of the present invention) even after male element 44' has been advanced through female element 42. Only after a medical practitioner has removed the wire constraining appendages 48 is lock 40'' fully engaged and deployment no longer reversible.

Lock 40''' of Figure 11C is similar to lock 40'' of Figure 11B, except that optional eyelets 49 on appendages 48 have been replaced by optional overtube 47. Overtube 47 serves a similar function to eyelets 49 by constraining appendages 48 to prevent locking until a medical practitioner has determined that apparatus of the present invention has been foreshortened and positioned adequately at a treatment site. Overtube 47 is then removed, which causes the appendages to resiliently expand, thereby fully actuating lock 40'''.

With reference to Figures 12, an alternative locking mechanism is described that is configured to engage the patient's aorta. Male interlocking elements 44''' of locks 40'''' comprise arrowheads 46' having sharpened appendages 48'. Upon expansion from the delivery configuration of Figure 12A to the foreshortened configuration of Figure 12B, apparatus 10 positions sharpened appendages 48' adjacent the patient's aorta A. Appendages 48' engage the aortic wall and reduce a risk of device migration over time.

With reference now to Figure 13, a risk of paravalvular leakage or regurgitation around apparatus of the present invention is described. In Figure 13, apparatus 10 has been implanted at the site of diseased aortic valve AV, for example, using techniques described hereinabove. The surface of native valve leaflets L is irregular, and interface I between leaflets L and anchor 30 may comprise gaps where blood B may seep through. Such leakage poses a risk of blood clot formation or insufficient blood flow.

Referring to Figure 14, optional elements for reducing regurgitation or leakage are described. Compliant sacs 200 may be disposed about the exterior of anchor 30 to provide a more efficient seal along irregular interface I. Sacs 200 may be filled with an appropriate material, for example, water, blood, foam or a hydrogel. Alternative fill materials will be apparent.

With reference to Figures 15, illustrative arrangements for sacs 200 are provided. In Figure 15A, sacs 200 are provided as discrete sacs at different positions along the height of anchor 30. In Figure 15B, the sacs are provided as continuous cylinders at various heights. In Figure 15C, a single sac is provided with a cylindrical shape that spans multiple heights. The sacs of Figure 15D are discrete, smaller and provided in larger quantities. Figure 15E provides a spiral sac. Alternative sac configurations will be apparent to those of skill in the art.

With reference to Figures 16, exemplary techniques for fabricating sacs 200 are provided. In Figure 16A, sacs 200 comprise 'fish-scale' slots 202 that may be back-filled, for example, with ambient blood passing through replacement valve 20. In Figure 16B, the sacs comprise pores 204 that may be used to fill the sacs. In Figure 16C, the sacs open to lumen 31 of anchor 30 and are filled by blood washing past the sacs as the blood moves through apparatus 10.

Figures 17 and 18 show yet another alternative embodiment of the anchor lock. Anchor 300 has a plurality of male interlocking elements 302 having eyelets 304 formed therein. Male interlocking elements are connected to braided structure 300 by inter-weaving elements 302 (and 308) or alternatively suturing, soldering, welding, or connecting with adhesive. Valve commissures 24 are connected to male interlocking elements 302 along their length. Replacement valve 20 annular base 22 is connected to the distal end 34 of anchor 300 (or 30) as is illustrated in figures 1A and 1B. Male interlocking elements 302 also include holes 306 that mate with tabs 310 extending into holes 312 in female interlocking elements 308. To lock, control wires 314 passing through eyelets 304 and holes 312 are pulled proximally with respect to the proximal end of braided anchor 300 to draw the male interlocking elements through holes 312 so that tabs 310 engage holes 306 in male interlocking elements 302. Also shown is release wires 314B that pass through eyelet 304B in female interlocking element 308. If needed, during the procedure, the user may pull on release wires 314B, thereby reversing orientation of tabs 310, releasing the anchor and allowing for repositioning of the device or its removal from the patient. Only when finally positioned as desired by the operating physician, would release wire 314B and control wire 314 be cut and removed from the patient with the delivery system.

Figures 19-21 show an alternative way of releasing the connection between the anchor and its actuating tubes and control wires. Control wires 62 extend through tubes 60 from outside the patient, loop through the proximal region of anchor 30 and extend partially back into tube 60. The doubled up portion of control wire 62 creates a force fit within tube 60 that maintains the control wire's position with respect to tube 60 when all control wires 62 are pulled proximally to place a proximally directed force on anchor 30. When a single control wire 62 is pulled proximally, however, the frictional fit between that control wire and the tube in which it is disposed is overcome, enabling the end 63 of control wire 62 to pull free of the tube, as shown in Figure 21, thereby releasing anchor 30.

Figures 22-24 show an alternative embodiment of the anchor. Anchor 350 is made of a metal braid, such as Nitinol or stainless steel. A replacement valve 354 is disposed within anchor 350 and supported by a replacement valve support, such as the posts described in earlier embodiments. Anchor 350 preferably is fabricated from a single strand of metal wire wound into the braid. It is expected that fabricating anchor 350 from a single strand of wire will facilitate deployment of the anchor, as well as retrieval of the anchor, by more evenly distributing forces applied to the anchor. Fabrication from a single strand is also expected to facilitate coupling of replacement valve 354 to the anchor, as well as coupling and decoupling of control wires (not shown) and tubes 352 thereto. Anchor 350 is actuated in substantially the same way as anchor 30 of Figures 1-4

through the application of proximally and distally directed forces from control wires and tubes 352 and may be locked in its expanded deployed configuration, as described above. The employed configuration of anchor 354 may have the shape and anchoring characteristics described with respect to other embodiments as well.

The braid forming anchor 350 (as well as that forming previously described anchor 30) optionally may be locally increased in diameter, e.g. via dipping in silicone or a hydrogel, in order to provide a better or complete seal against the patient's anatomy. An improved seal is expected to reduce paravalvular leakage, as well as migration of the anchor over time. The local increase in diameter of the braid may, for example, be provided over a full radial segment of anchor 350.

Figures 25 and 26 show yet another embodiment of the delivery and deployment apparatus of the invention. As an alternative to the balloon expansion method described with respect to Figures 8, in this embodiment the nosecone (e.g., element 102 of Figures 5) is replaced by an angioplasty balloon catheter 360. Thus, angioplasty balloon catheter 360 precedes sheath 110 on guidewire G. When anchor 30 and valve 20 are expanded through the operation of tubes 60 and the control wires (not shown) as described above, balloon catheter 360 is retracted proximally within the expanded anchor and valve and expanded further as described above with respect to Figures 8.

As an alternative, or in addition, to further expansion of balloon catheter 360 within valve 20 and expanded anchor 30 to further expand the anchor, the balloon may be deflated prior to proximal retraction within and past the valve and anchor. In this manner, balloon catheter 360 may act as an atraumatic nosecone during delivery of valve 20 and anchor 30, but then may be deflated to provide a reduced profile, as compared to a standard nosecone, during retrieval of the balloon catheter through the deployed valve. It is expected that a smaller balloon catheter 360 may be provided when the catheter is utilized merely in place of a nosecone than when the catheter is also utilized to complete expansion of anchor 30.

Figures 27-31 show seals 370 that expand over time to seal the interface between the anchor and valve and the patient's tissue. Seals 370 are preferably formed from Nitinol wire surrounded by an expandable foam. As shown in cross-section in Figures 28 and 29, at the time of deployment, the foam 372 is compressed about the wire 374 and held in the compressed form by a time-released coating 376. After deployment, coating 376 dissolves in vivo to allow foam 372 to expand, as shown in Figures 30 and 31.

Figures 32-34 show another way to seal the replacement valve against leakage. A fabric seal 380 extends from the distal end of valve 20 and back proximally over anchor 30 during delivery. When deployed, as shown in Figures 33 and 34, fabric seal 380 bunches up to create fabric flaps and pockets that extend into spaces formed by the native valve leaflets 382, particularly when the pockets are filled with blood in response to backflow blood pressure. This arrangement creates a seal around the replacement valve.

Figures 35A-H show another embodiment of a replacement heart valve apparatus in accordance with the present invention. Apparatus 450 comprises replacement valve 460 (see Figures 37B and 38C) disposed within and coupled to anchor 470. Replacement valve 460 is preferably biologic, e.g. porcine, but alternatively may be synthetic. Anchor 470 preferably is fabricated from self-expanding materials, such as a stainless steel wire mesh or a nickel-titanium alloy ("Nitinol"), and comprises lip region 472, skirt region 474, and body regions 476a, 476b and 476c. Replacement valve 460 preferably is coupled to skirt region 474, but alternatively may be coupled to other regions of the anchor. As described hereinbelow, lip region 472 and skirt region 474

are configured to expand and engage/capture a patient's native valve leaflets, thereby providing positive registration, reducing paravalvular regurgitation, reducing device migration, etc.

As seen in Figure 35A, apparatus 450 is collapsible to a delivery configuration, wherein the apparatus may be delivered via delivery system 410. Delivery system 410 comprises sheath 420 having lumen 422, as well as wires 424a and 424b seen in Figures 35D-35G. Wires 424a are configured to expand skirt region 474 of anchor 470, as well as replacement valve 460 coupled thereto, while wires 424b are configured to expand lip region 472.

As seen in Figure 35B, apparatus 450 may be delivered and deployed from lumen 422 of catheter 420 while the apparatus is disposed in the collapsed delivery configuration. As seen in Figures 35B-35D, catheter 420 is retracted relative to apparatus 450, which causes anchor 470 to dynamically self-expand to a partially deployed configuration. Wires 424a are then retracted to expand skirt region 474, as seen in Figures 35E and 35F. Preferably, such expansion may be maintained via locking features described hereinafter.

In Figure 35G, wires 424b are retracted to expand lip region 472 and fully deploy apparatus 450. As with skirt region 474, expansion of lip region 472 preferably may be maintained via locking features. After both lip region 472 and skirt region 474 have been expanded, wires 424 may be removed from apparatus 450, thereby separating delivery system 410 from the apparatus. Delivery system 410 then may be removed, as seen in Figure 35H.

As will be apparent to those of skill in the art, lip region 472 optionally may be expanded prior to expansion of skirt region 474. As yet another alternative, lip region 472 and skirt region 474 optionally may be expanded simultaneously, in parallel, in a step-wise fashion or sequentially. Advantageously, delivery of apparatus 450 is fully reversible until lip region 472 or skirt region 474 has been locked in the expanded configuration.

With reference now to Figures 36A-E, individual cells of anchor 470 of apparatus 450 are described to detail deployment and expansion of the apparatus. In Figure 36A, individual cells of lip region 472, skirt region 474 and body regions 476a, 476b and 476c are shown in the collapsed delivery configuration, as they would appear while disposed within lumen 422 of sheath 420 of delivery system 410 of Figures 35. A portion of the cells forming body regions 476, for example, every 'nth' row of cells, comprises locking features.

Body region 476a comprises male interlocking element 482 of lip lock 480, while body region 476b comprises female interlocking element 484 of lip lock 480. Male element 482 comprises eyelet 483. Wire 424b passes from female interlocking element 484 through eyelet 483 and back through female interlocking element 484, such that there is a double strand of wire 424b that passes through lumen 422 of catheter 420 for manipulation by a medical practitioner external to the patient. Body region 476b further comprises male interlocking element 492 of skirt lock 490, while body region 476c comprises female interlocking element 494 of the skirt lock. Wire 424a passes from female interlocking element 494 through eyelet 493 of male interlocking element 492, and back through female interlocking element 494. Lip lock 480 is configured to maintain expansion of lip region 472, while skirt lock 490 is configured to maintain expansion of skirt region 474.

In Figure 36B, anchor 470 is shown in the partially deployed configuration, e.g., after deployment from lumen 422 of sheath 420. Body regions 476, as well as lip region 472 and skirt region 474, self-expand to the partially deployed configuration. Full deployment is then achieved by retracting wires 424 relative to anchor

470, and expanding lip region 472 and skirt region 474 outward, as seen in Figures 36C and 36D. As seen in Figure 36E, expansion continues until the male elements engage the female interlocking elements of lip lock 480 and skirt lock 490, thereby maintaining such expansion (lip lock 480 shown in Figure 36E).

Advantageously, deployment of apparatus 450 is fully reversible until lip lock 480 and/or skirt lock 490 has been actuated.

With reference to Figures 37A-B, isometric views, partially in section, further illustrate apparatus 450 in the fully deployed and expanded configuration. Figure 37A illustrates the wireframe structure of anchor 470, while Figure 37B illustrates an embodiment of anchor 470 covered in a biocompatible material **B**. Placement of replacement valve 460 within apparatus 450 may be seen in Figure 37B. The patient's native valve is captured between lip region 472 and skirt region 474 of anchor 470 in the fully deployed configuration (see Figure 38B).

Referring to Figures 38A-C, in conjunction with Figures 35 and 36, a method for endovascularly replacing a patient's diseased aortic valve with apparatus 450 is described. Delivery system 410, having apparatus 450 disposed therein, is endovascularly advanced, preferably in a retrograde fashion, through a patient's aorta **A** to the patient's diseased aortic valve **AV**. Sheath 420 is positioned such that its distal end is disposed within left ventricle **LV** of the patient's heart **H**. As described with respect to Figures 35, apparatus 450 is deployed from lumen 422 of sheath 420, for example, under fluoroscopic guidance, such that skirt section 474 is disposed within left ventricle **LV**, body section 476b is disposed across the patient's native valve leaflets **L**, and lip section 472 is disposed within the patient's aorta **A**. Advantageously, apparatus 450 may be dynamically repositioned to obtain proper alignment with the anatomical landmarks. Furthermore, apparatus 450 may be retracted within lumen 422 of sheath 420 via wires 424, even after anchor 470 has dynamically expanded to the partially deployed configuration, for example, to abort the procedure or to reposition sheath 420.

Once properly positioned, wires 424a are retracted to expand skirt region 474 of anchor 470 within left ventricle **LV**. Skirt region 474 is locked in the expanded configuration via skirt lock 490, as previously described with respect to Figures 36. In Figure 38A, skirt region 474 is maneuvered such that it engages the patient's valve annulus **An** and/or native valve leaflets **L**, thereby providing positive registration of apparatus 450 relative to the anatomical landmarks.

Wires 424b are then actuated external to the patient in order to expand lip region 472, as previously described in Figures 35. Lip region 472 is locked in the expanded configuration via lip lock 480.

Advantageously, deployment of apparatus 450 is fully reversible until lip lock 480 and/or skirt lock 490 has been actuated. Wires 424 are pulled from eyelets 483 and 493, and delivery system 410 is removed from the patient. As will be apparent, the order of expansion of lip region 472 and skirt region 474 may be reversed, concurrent, etc.

As seen in Figure 38B, lip region 472 engages the patient's native valve leaflets **L**, thereby providing additional positive registration and reducing a risk of lip region 472 blocking the patient's coronary ostia **O**. Figure 38C illustrates the same in cross-sectional view, while also showing the position of replacement valve 460. The patient's native leaflets are engaged and/or captured between lip region 472 and skirt region 474. Advantageously, lip region 472 precludes distal migration of apparatus 450, while skirt region 474 precludes proximal migration. It is expected that lip region 472 and skirt region 474 also will reduce paravalvular regurgitation.

Referring now to Figures 39, an embodiment of apparatus in accordance with the present invention is described, wherein the replacement valve is not connected to the expandable portion of the anchor. Rather, the replacement valve is wrapped about an end of the anchor. Such wrapping may be achieved, for example, by everting the valve during endovascular deployment.

5 In Figures 39, apparatus 500 comprises expandable anchor 30' and everting replacement valve 520, as well as delivery system 100' for endoluminally delivering and deploying the expandable anchor and everting valve. Expandable anchor 30' illustratively is described as substantially the same as previously described anchor 30 of Figures 1-4; however, it should be understood that anchor 30' alternatively may be substantially the same as anchor 300 of Figures 17 and 18, anchor 350 of Figures 24-26, or anchor 470 of Figures 35. As
10 with anchor 30, anchor 30' comprises posts 38 and locks (comprised of elements 523 and 532). Alternative locks may be provided, such as locks 40', 40'', 40''' or 40'''' of Figures 11 and 12, or the reversible lock of anchor 300 described with respect to Figures 17 and 18.

Everting valve 520 is similar to previously described valve 20, in that commissures 524 of replacement valve leaflets 526 are coupled to and supported by posts 38 of anchor 30'. However, annular base 522 of
15 replacement valve 520 is not coupled to anchor 30'. Rather, annular base 522 is coupled to everting segment 528 of everting replacement valve 520. Everting segment 528 is disposed distal of anchor 30' in the delivery configuration and is configured to wrap about the distal end of the anchor during deployment, such as by everting, thereby holding (such as by friction locking) replacement valve 520 between the anchor and the patient's tissue, thereby creating a seal between the anchor and the patient's tissue. In this manner, replacement
20 valve 520 is entirely disconnected from the expandable/collapsible portion of anchor 30', and a delivery profile of apparatus 500 is reduced, as compared to previously described apparatus 10.

Everting segment 528 of valve 520 may be fabricated from the same material as valve leaflets 526, e.g., a biologic tissue or a polymeric material. Alternatively, the segment may comprise a fabric, such as a permeable or impermeable fabric, a fabric that promotes or retards tissue ingrowth, a sealing foam, etc. Additional
25 materials will be apparent.

Delivery system 100' for use with anchor 30' and replacement valve 520, is similar to previously described delivery system 100. The delivery system comprises sheath 110' having lumen 112', in which anchor 30' may be collapsed for delivery. Control wires 50, tubes 60 and control wires 62 have been provided to deploy, foreshorten, retrieve, etc., anchor 30', as discussed previously, and optional balloon catheter 360 has
30 been provided as a collapsible nosecone (see Figure 25). In delivery system 100', the posts are connected to the distal end of the anchor and the everting valve is connected to the posts. Delivery system 100' differs from system 100 in that it further comprises eversion control wires 550, which may, for example, be fabricated from suture.

Control wires 550 are coupled to a distal region of everting segment 528 of valve 520, and then pass
35 proximally out of the patient external to anchor 30' for manipulation by a medical practitioner. Control wires 550 preferably are kept taut to keep everting segment 528 in tension. Upon retraction of sheath 110' relative to anchor 30' and valve 520 (or advancement of the anchor and valve relative to the sheath), the tension applied to segment 528 by wires 550 causes the segment to evert and wrap about the distal end of anchor 30'. Anchor 30' then may be expanded and deployed as described previously, thereby friction locking everting segment 528
40 between the anchor and the patient's anatomy.

Figures 39 illustrate a device and method for endovascularly replacing a patient's diseased aortic valve utilizing apparatus 500. In Figure 39A, sheath 110' of delivery system 100', having expandable anchor 30' and evert ing valve 520 disposed therein within lumen 112', is endovascularly advanced over guide wire **G**, preferably in a retrograde fashion (although an antegrade or hybrid approach alternatively may be used), through a patient's aorta **A** to the patient's diseased aortic valve **AV**. Balloon catheter nosecone 360 precedes sheath 110'. Sheath 110' is positioned such that its distal region is disposed within left ventricle **LV** of the patient's heart **H**. In Figure 39A, wires 550 pass from segment 528 and lumen 112' to the exterior of sheath 110' via through-holes 111a', and then more proximally pass back into the interior of sheath 110' via through-holes 111b', which are disposed proximal of anchor 30'.

Figure 39B is a blow-up of the intersection of tubes 60, wires 62 and anchor 30'.

Figure 39C illustrates the beginning of the evert ing process wherein evert ing segment 528 is being pulled proximally over the exterior of anchor 30'. As seen in Figure 39C, which provides an isometric view of the device, the inflatable element of balloon catheter 360 is deflated and further distally advanced within left ventricle **LV** along guide wire **G** relative to sheath 110'. Anchor 30' and replacement valve 520 then are advanced relative to the sheath via tubes 60 and control wires 62, thereby deploying evert ing segment 528 of valve 520, as well as a distal region of anchor 30', from the distal end of lumen 112'. Tension applied to evert ing segment 528 via control wires 550 connected through eyelets 529 causes the segment to wrap about the distal region of anchor 30' by evert ing.

In Figure 39C, wires 550 may pass distally from evert ing segment 528 out the distal end of lumen 112' of sheath 110', then proximally along the interior surface of the sheath all the way out of the patient. Optional through-holes 111b' allow wires 550 to be disposed within lumen 112' along a majority of their length. Wires 550 may also pass back into multi-lumen sheath 180.

Figure 39D provides a cross sectional view of apparatus 500 after replacement valve 520 has everted about anchor 30'. This and other cross sectional figures portray a 120° view of the apparatus herein. Sheath 110' is then retracted relative to anchor 30' and valve 520, which deploys a remainder of the anchor and the replacement valve from lumen 112' of the sheath. Such deployment may be conducted, for example, under fluoroscopic guidance. Anchor 30' dynamically self-expands to a partially deployed configuration.

Advantageously, anchor 30' and replacement valve 520 may be retrieved and retracted within the lumen of sheath 110' via retraction of multi-lumen catheter 180 to which tubes 60 are attached and release of wires 50. Such retrieval of apparatus 500 may be achieved even after segment 528 has been wrapped about anchor 30', and even after anchor 30' has dynamically expanded to the partially deployed configuration. Retrieval of apparatus 500 may be utilized, for example, to abort the procedure or to reposition the apparatus. As yet another advantage, anchor 30' and valve 520 may be dynamically repositioned, e.g. via proximal retraction of multi-lumen catheter 180 and/or release of wires 50, in order to properly align the apparatus relative to anatomical landmarks, such as the patient's coronary ostia **O** or the patient's native valve leaflets **L**.

Once properly aligned sheath 110', tubes 60 and wires 62 are advanced relative to wires 50 and 550 to impose foreshortening upon anchor 30', thereby expanding the anchor to the fully deployed configuration, as in Figure 39G. Foreshortening friction locks evert ing segment 528 of valve 520 between anchor 30' and annulus **An**/leaflets **L** of the patient's diseased valve, thus properly seating the valve within the anchor while providing an improved seal between the replacement and native valves that is expected to reduce paravalvular

regurgitation. Foreshortening also increases a radial strength of anchor 30', which is expected to prolong patency of valve annulus **An**. Furthermore, foreshortening actuates the anchor's locks, which maintain such imposed foreshortening.

5 Deployment of anchor 30' and replacement valve 520 advantageously is fully reversible until the anchor locks have been actuated. Furthermore, if the anchor's locks are reversible locks or buckles, such as those described in conjunction with anchor 300 of Figures 17 and 18, deployment of the anchor and valve may be fully reversible even after actuation of the locks/buckles, right up until delivery system 100' is decoupled from the replacement apparatus.

10 As seen in Figure 39G, in order to complete deployment of anchor 30' and replacement valve 520, wires 50 of delivery system 100' are decoupled from posts 38 of anchor 30', tubes 60 are decoupled from anchor 30', e.g. via wires 62, and wires 550 are decoupled from friction-locked everting segment 528 of replacement valve 520. Figure 39E illustrates how wires 50 are associated with posts 38. In one example, wires 50 are decoupled from posts 38 by pulling on one of the wires. Decoupling of the wires and tubes may also be achieved, for example, via eyelets (see Figures 4E, 19-21 and 39E) or via cutting of the wires. Delivery system
15 100' then is removed from the patient, as are deflated balloon catheter 360 and guide wire **G**, both of which are retracted proximally across the replacement valve and anchor. Normal blood flow between left ventricle **LV** and aorta **A** thereafter is regulated by replacement valve 520. Figure 39F is a blow up illustration of replacement valves 526 which are connected to everting segment 528, wherein everting segment 528 has been everted around anchor 30'.

20 Referring now to Figures 40, an alternative embodiment of everting apparatus in accordance with the present invention is described, wherein the posts are connected and the everting valve is disposed within the anchor to the proximal end of the anchor in the delivery configuration. In Figures 40, apparatus 600 comprises everting replacement valve 620 and anchor 630, as well as previously described delivery system 100'. Replacement valve 620 and anchor 630 are substantially the same as valve 520 and anchor 30' of Figures 39,
25 except that valve 620 is initially seated more proximally within anchor 630, such that everting segment 628 of valve 620 is initially disposed within the anchor. Locking mechanisms as described previously may be implemented at the distal end of the post and anchor or proximal end of everted segment and anchor.

30 As with replacement valve 520, everting segment 628 of valve 620 is configured to wrap about the distal end of anchor 630 by everting during deployment, thereby friction locking the replacement valve between the anchor and the patient's anatomy. Furthermore, replacement valve 620 is entirely disconnected from the expandable/collapsible portion of anchor 630. In the delivery configuration, since only a single circumferential layer of valve 620 is present along any cross section of apparatus 600, a delivery profile of the apparatus is reduced, as compared to previously described apparatus 10. With apparatus 10, two circumferential layers of valve 20 are present in the cross section where annular base 22 of the valve is coupled to the expandable anchor
35 30.

40 Figures 40 illustrate a method of endovascularly replacing a patient's diseased aortic valve utilizing apparatus 600. In Figure 40A, apparatus 600 is endovascularly advanced into position with valve 620 and anchor 630 disposed within lumen 112' of sheath 110' of delivery system 100'. As seen in Figure 40B, the valve and anchor are advanced relative to the sheath and/or the sheath is retracted relative to the valve and anchor, which deploys everting segment 628 of the valve, as well as a distal region of the anchor. Tension

applied to the everting segment via control wires 550 causes the segment to evert and wrap about the distal region of anchor 630. Control wires 550 may enter the multi-lumen catheter at the distal end of the catheter or more proximally as is illustrated in 40C. Further retraction of sheath 110' deploys a remainder of replacement valve 620 and anchor 630 from lumen 112' of the sheath. Such deployment may be conducted, for example, under fluoroscopic guidance. Anchor 630 dynamically self-expands to a partially deployed configuration.

Once the anchor and valve have been properly aligned in relation to anatomical landmarks, foreshortening is imposed upon anchor 630 to expand the anchor to the fully deployed configuration, as in Figure 40C. At this point, Locks may be actuated as previously described. Foreshortening friction locks everting segment 628 of valve 620 between anchor 630 and annulus **An**/leaflets **L** of the patient's diseased valve, thus properly seating the valve within the anchor while providing an improved seal between the replacement and native valves. Foreshortening also increases a radial strength of anchor 630, which is expected to prolong patency of valve annulus **An**. Deployed valve 620 and anchor 630 then are decoupled from delivery system 100', as in Figure 40D, thereby completing deployment of apparatus 600. Thereafter, normal blood flow between left ventricle **LV** and aorta **A** is regulated by replacement valve 620.

As with apparatus 500, apparatus 600 may be dynamically repositioned during deployment, for example, in order to properly align the apparatus relative to anatomical landmarks. Furthermore, apparatus 600 advantageously may be retrieved at any point at least up until actuation of optimal locks maintaining foreshortening. When the optional locks are reversible, retrieval may be achieved until valve 620 and anchor 630 are separated from delivery system 100'.

Figures 41 illustrate an alternative embodiment of the present invention wherein the everting valve is distal to the anchor and the posts are not connected to the braid in the delivery configuration. As is illustrated in Figure 41A, apparatus 700 comprises everting valve 720 and expandable anchor 730, as well as delivery system 750. Delivery system 750 includes multi-lumen catheter 180. Anchor 730 is fabricated from an expandable braid and comprises female/male element 732 of a locking mechanism, which is preferably reversible. Everting valve 720 comprises valve leaflets 726 and everting segment 728. Everting valve 720 further comprises posts 722 to which valve leaflets 726 are attached to provide commissure support. Posts 722, which are non-expandable and non-collapsible, comprise opposite male/female elements 723 of locking mechanism comprising eyelets. In the delivery configuration of Figure 41A, anchor 730 may extend distally far enough to just overlap the proximal-most section of valve 720.

Delivery system 750 is similar to previously described delivery system 100' and includes multi-lumen catheter 180. As with previous embodiments, delivery system 750 facilitates dynamic repositioning and/or retrieval of apparatus 700 after partial or full deployment of the apparatus, e.g., right up until the apparatus is separated from the delivery system.

As seen in Figure 41A, wires 50 pass from the multi-lumen catheter 180 through the female/male locking mechanism 732, which is associated with anchor 730. Wires 50 then further pass through female/male locking mechanism 723, which is at the proximal end of posts 722. Preferably, a double strand of each wire 50 is provided to facilitate decoupling of wires 50 from valve 720 and anchor 730 in the manner described previously. When wires 50 are pulled proximally into the multi lumen catheter 180, posts 722 move proximally within anchor 730, and the female/male element 723 interacts with female/male element 732 of anchor 730. In this embodiment, when element 723 is male, then element 732 is female, and vice versa.

Thus, valve 720 and anchor 730 are entirely decoupled from one another in the delivery configuration. Wires 50 are configured to approximate the telescoped valve and anchor, as well as to actuate locking mechanism 740 and contribute to foreshortening of anchor 730. By separating valve 720 and anchor 730 within lumen 112' of sheath 110', a delivery profile of apparatus 700 may be reduced.

5 In Figure 41A, apparatus 700 is endovascularly advanced into position with valve 720 and anchor 730 spaced from one another within lumen 112' of sheath 110' of delivery system 750. Substantially all of valve 720 and its supporting posts 722 are disposed distal to the anchor during delivery. As seen in Figure 41B, to evert valve 720, sheath 110' is pulled proximally around anchor 730.

10 Next, in Figure 41C, to approximate anchor 730 and valve 720, the elongated braid of anchor 730 is pushed distally to the base of posts 722 using tubes 60 maintained in association with anchor 730 by wire 62. Anchor 730 will engage with the distal end of posts 722 - an anchor engagement feature 729. In some embodiments, as illustrated in Figure 41C, wires 550 re-enter sheath 110' proximal to the distal end of the multi-lumen catheter 180.

15 In Figure 41D, the multi-lumen catheter 180 is held steady, while wires 50 are pulled proximally. This allows the foreshortening of anchor 730 and the engagement of the male and female elements of locking mechanism of 740. Foreshortening friction locks segment 728 of valve 720 against valve annulus **An**/leaflets **L**, thereby properly seating the valve within anchor 730. Foreshortening also completes expansion of anchor 730 and actuates locking mechanism 740, which maintains such expansion of the anchor. Delivery system 750 then may be decoupled from valve 720 and anchor 730, thereby completing deployment of apparatus 700. Normal
20 blood flow between left ventricle **LV** and aorta **A** thereafter is regulated by replacement valve 720.

With reference now to Figures 42, yet another alternative embodiment of everting apparatus in accordance with the present invention is described, wherein the replacement valve leaflets evert and wrap about the distal region of the anchor. Apparatus 800 comprises everting replacement valve 820 and expandable anchor 830. Valve 820 comprises posts 822, to which valve leaflets 826 are attached. The valve further
25 comprises everting segment 828. Proximal regions 823 of posts 822 are rotatably coupled to a distal region of anchor 830, while distal regions 824 of the posts are coupled to control wires 50.

In the delivery configuration of Figure 42A, posts 822 (and, thus, valve leaflets 826) and everting segment 828 of replacement valve 820 are disposed distal of anchor 830. Figure 42B illustrates deployment of apparatus 800, whereby tubes 60/wires 62 (see, e.g., Figures 41) are actuated in conjunction with control wires
30 50 to actively foreshorten anchor 830 and rotate posts 822 into position within the lumen of anchor 830, thereby everting valve leaflets 826 into position within the anchor. Furthermore, eversion wires 550 are actuated to evert segment 828 and wrap the segment about the exterior of anchor 830. Locks 840 maintain expansion and foreshortening of anchor 830.

Referring to Figures 43, an everting embodiment of the present invention is described wherein a
35 portion of the locking mechanism configured to maintain expansion of the anchor is coupled to the everting segment of the replacement valve instead of, or in addition to, the anchor posts and anchor posts **P** are only loosely associated with the anchor 930. Apparatus 900 comprises replacement valve 920 and anchor 930. Everting segment 928 of the replacement valve comprises male elements 942 of locks 940, while anchor 930 comprises female elements 944 of locks 940. Upon deployment of apparatus 900 from the delivery
40 configuration of Figure 43A to the deployed configuration of Figure 43B, segment 928 of replacement valve

920 everts to wrap about the exterior of anchor 930, which is actively foreshortened during expansion. Locks 940 maintain anchor expansion.

With reference to Figures 44, another telescoping embodiment of the present invention is described wherein the replacement valve comprises a U-shaped frame configured to receive the anchor. Optionally, the valve may comprise an everting segment that everts about the frame and/or the anchor during deployment. Apparatus 1000 comprises replacement valve 1020 and expandable anchor 1030. Replacement valve 1020 comprises frame 1022, leaflets 1026 and optional everting segment 1028.

Valve 1020 and anchor 1030 are configured for relative movement, such that the valve and anchor may be telescoped and spaced apart during delivery, thereby reducing a delivery profile of apparatus 1000, but may be approximated during deployment. Everting segment 1028 of valve 1020 optionally may be disposed distal of valve frame 1022 during delivery, thereby further reducing a delivery profile of apparatus 1000, then everted during deployment.

As seen in Figure 44A, the U-shape of valve frame 1022 preferably tilts leaflets 1026 of replacement valve 1020 slightly inward relative to blood flow through apparatus 1000. As seen in Figure 44B, valve frame 1022 optionally may comprise a symmetric U-shape, which captures anchor 1030 on both sides in the deployed configuration. Frame 1022 may comprise lock 1040 that closes the frame's U-shape into an elliptical shape in the deployed configuration, thereby maintaining expansion of anchor 1030.

Prior to implantation of one of the replacement valves described above, it may be desirable to perform a valvuloplasty on the diseased valve by inserting a balloon into the valve and expanding it using saline mixed with a contrast agent. In addition to preparing the valve site for implant, fluoroscopic viewing of the valvuloplasty will help determine the appropriate size of replacement valve implant to use.

WHAT IS CLAIMED IS:

1. Apparatus for endovascularly replacing a patient's heart valve, the apparatus comprising:
a replacement valve; and
an expandable anchor,
5 wherein the replacement valve and the expandable anchor are configured for endovascular delivery to a vicinity of the patient's heart valve, and
wherein at least an everting portion of the replacement valve is configured to evert about the anchor during endovascular deployment.
2. The apparatus of claim 1, wherein the everting portion of the replacement valve is configured
10 to create a seal between the anchor and patient tissue.
3. The apparatus of claim 1, wherein the replacement valve is adapted to be held between the anchor and patient tissue upon eversion of the everting portion of the replacement valve about the anchor and expansion of the anchor.
4. The apparatus of claim 1 wherein at least a portion of the replacement valve is configured to
15 be endovascularly delivered distal to the anchor.
5. The apparatus of claim 4 wherein substantially the entire replacement valve is configured to be endovascularly delivered distal to the anchor.
6. The apparatus of claim 1 further comprising a delivery system configured to endovascularly deliver the replacement valve and the anchor.
- 20 7. The apparatus of claim 6, wherein the delivery system is configured to evert the replacement valve.
8. The apparatus of claim 6, wherein the delivery system is configured to change the anchor's shape.
9. The apparatus of claim 8, wherein the delivery system is configured to actively foreshorten the
25 anchor.
10. The apparatus of claim 1, wherein the anchor and the replacement valve are telescoped relative to one another during endovascular delivery.
11. The apparatus of claim 1 further comprising a lock configured to maintain anchor expansion.
12. The apparatus of claim 1, wherein the anchor further comprises lip and skirt regions
30 configured to expand and engage the patient's heart valve.
13. The apparatus of claim 1, wherein the anchor further comprises a braid fabricated from a single strand of wire.
14. The apparatus of claim 1, wherein the replacement valve further comprises valve leaflets.
15. The apparatus of claim 14, wherein the everting segment comprises a material chosen from
35 the group consisting of biologic materials, polymeric materials, fabric materials, permeable materials, impermeable materials, materials that promote tissue ingrowth, materials that retard tissue ingrowth, foam materials, sealing materials, and combinations thereof.
16. The apparatus of claim 1, further comprising a replacement valve support adapted to support the replacement valve in a deployed configuration.

17. The apparatus of claim 16, further comprising a supporting connection between the replacement valve and the replacement valve support.

18. The apparatus of claim 17, wherein the supporting connection is adapted to support replacement valve commissures.

5 19. The apparatus of claim 16, wherein the replacement valve support and at least a portion of the anchor are adapted to move with respect to each other during endovascular deployment of the anchor and replacement valve.

20. The apparatus of claim 16, wherein the replacement valve support comprises a lock adapted to lock configured to maintain anchor expansion.

10 21. Apparatus for endovascularly replacing a patient's heart valve, the apparatus comprising:
an anchor having a lip region and a skirt region; and
a replacement valve,
wherein at least an everting portion of the replacement valve is configured to evert about the skirt region of the anchor during endovascular deployment, and
15 wherein the lip and skirt regions of the anchor are configured for percutaneous expansion to engage the patient's heart valve.

22. The apparatus of claim 21, wherein percutaneous expansion of the skirt region is configured to hold the everting portion of the replacement valve between the skirt region and the patient's heart valve.

20 23. The apparatus of claim 21, wherein the everting portion of the replacement valve is configured to create a seal between the anchor and patient tissue.

24. The apparatus of claim 21, wherein the anchor further comprises a braid fabricated from a single strand of wire.

25 25. Apparatus for endovascularly replacing a patient's heart valve, the apparatus comprising:
a replacement valve; and
an expandable anchor,
wherein the replacement valve and the anchor are configured for endovascular delivery to a vicinity of the patient's heart valve with no portion of the replacement valve being wrapped about the anchor,
and

30 wherein at least a wrapping portion of the replacement valve is configured to be wrapped about an end of the anchor in a deployed configuration.

26. The apparatus of claim 25, wherein the wrapping portion of the replacement valve is configured to create a seal between the anchor and patient tissue.

27. The apparatus of claim 25 wherein at least a portion of the replacement valve is configured to be endovascularly delivered distal to the anchor.

35 28. The apparatus of claim 27 wherein substantially the entire replacement valve is configured to be endovascularly delivered distal to the anchor.

29. The apparatus of claim 25, wherein the replacement valve is not connected to the expandable anchor.

40 30. The apparatus of claim 25, wherein at least a portion of the replacement valve is configured to evert about the anchor during endovascular deployment.

31. The apparatus of claim 25, wherein the wrapped portion of the replacement valve is configured to be held between the anchor and the patient tissue upon endovascular deployment.

32. The apparatus of claim 25, wherein the expandable anchor is configured for active foreshortening during endovascular deployment.

5 33. The apparatus of claim 25 further comprising a lock configured to maintain expansion of the anchor.

34. The apparatus of claim 25, wherein the lock is reversible.

35. The apparatus of claim 25, further comprising a replacement valve support adapted to support the replacement valve in a deployed configuration.

10 36. The apparatus of claim 35, further comprising a supporting connection between the replacement valve and the replacement valve support.

37. The apparatus of claim 36, wherein the supporting connection is adapted to support replacement valve commissures.

15 38. The apparatus of claim 35, wherein the replacement valve support is adapted to move with respect to the anchor during endovascular deployment of the anchor and replacement valve.

39. The apparatus of claim 35, wherein the replacement valve support comprises a lock adapted to lock configured to maintain anchor expansion.

40. The apparatus of claim 35, wherein the anchor comprises a braid fabricated from a single strand of wire.

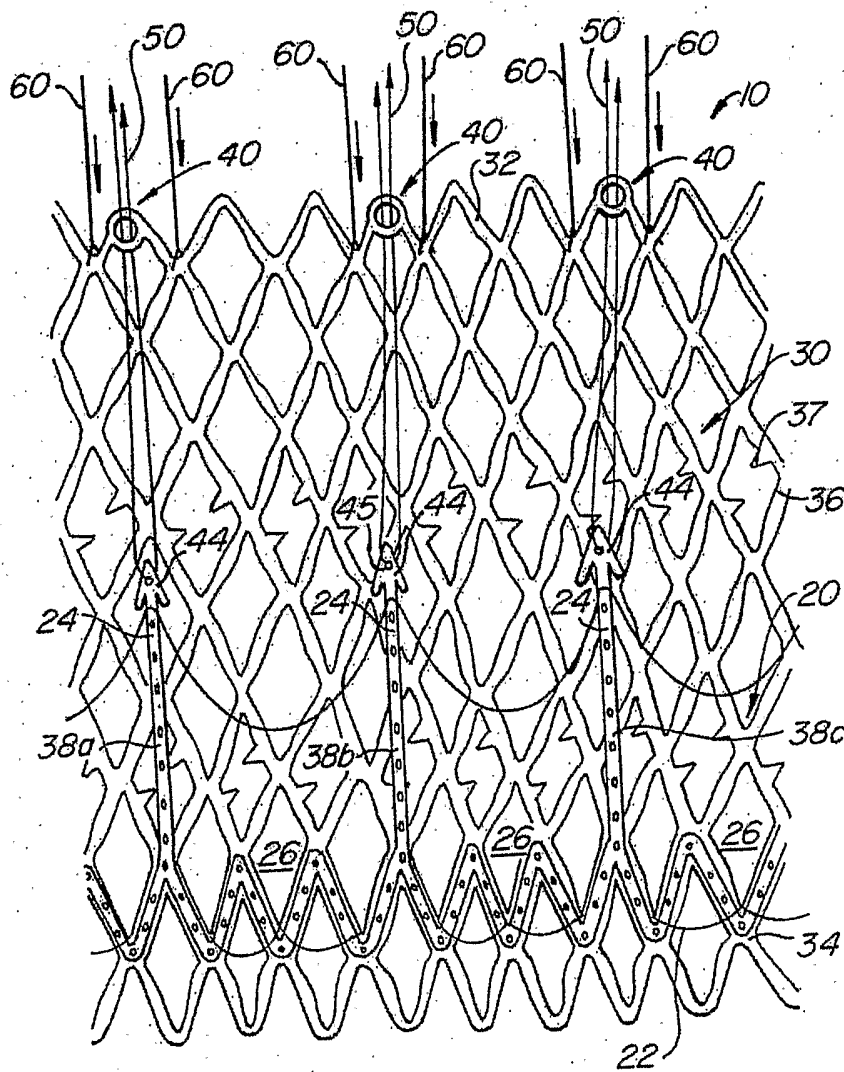

FIG. 1A

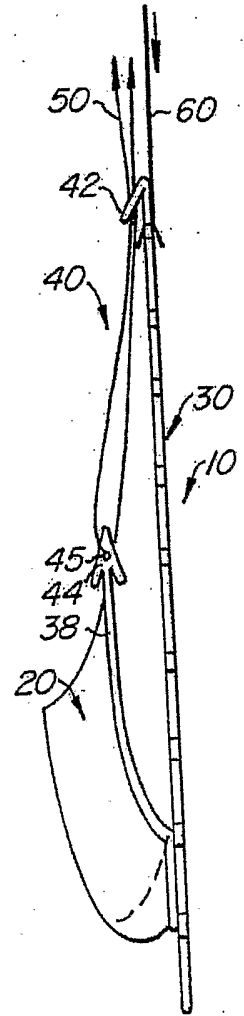

FIG. 2A

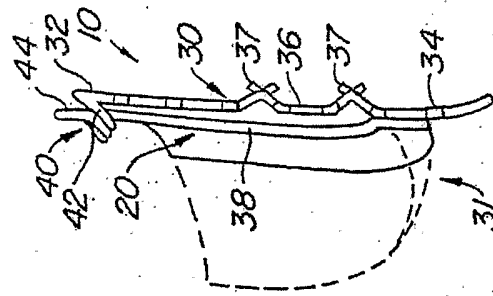

FIG. 2B

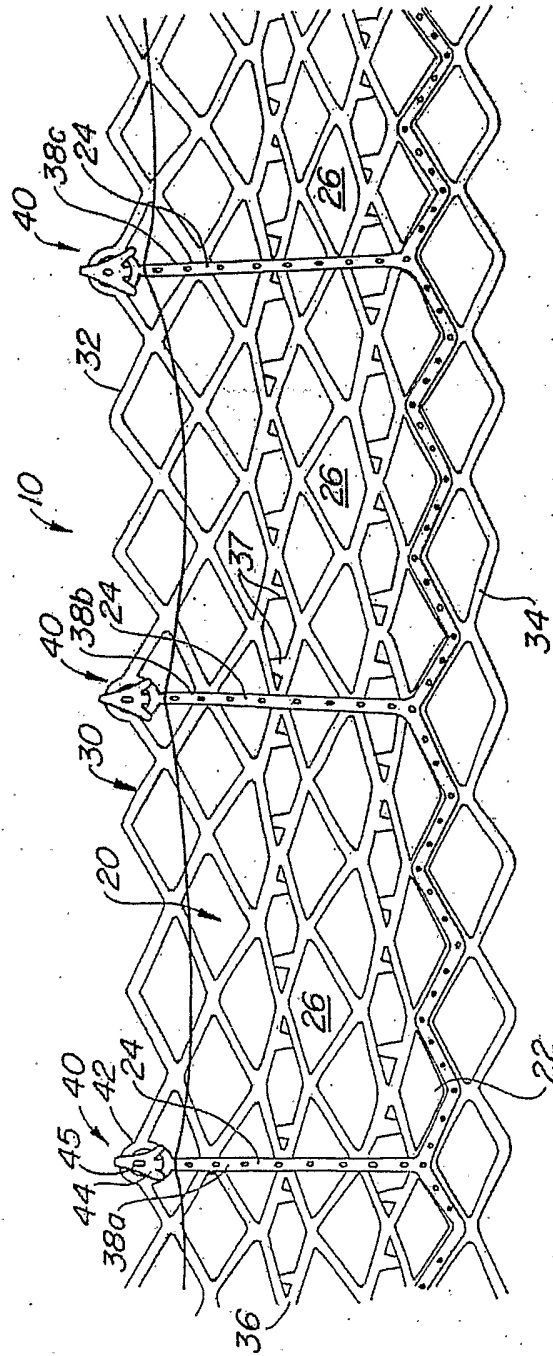

FIG. 1B

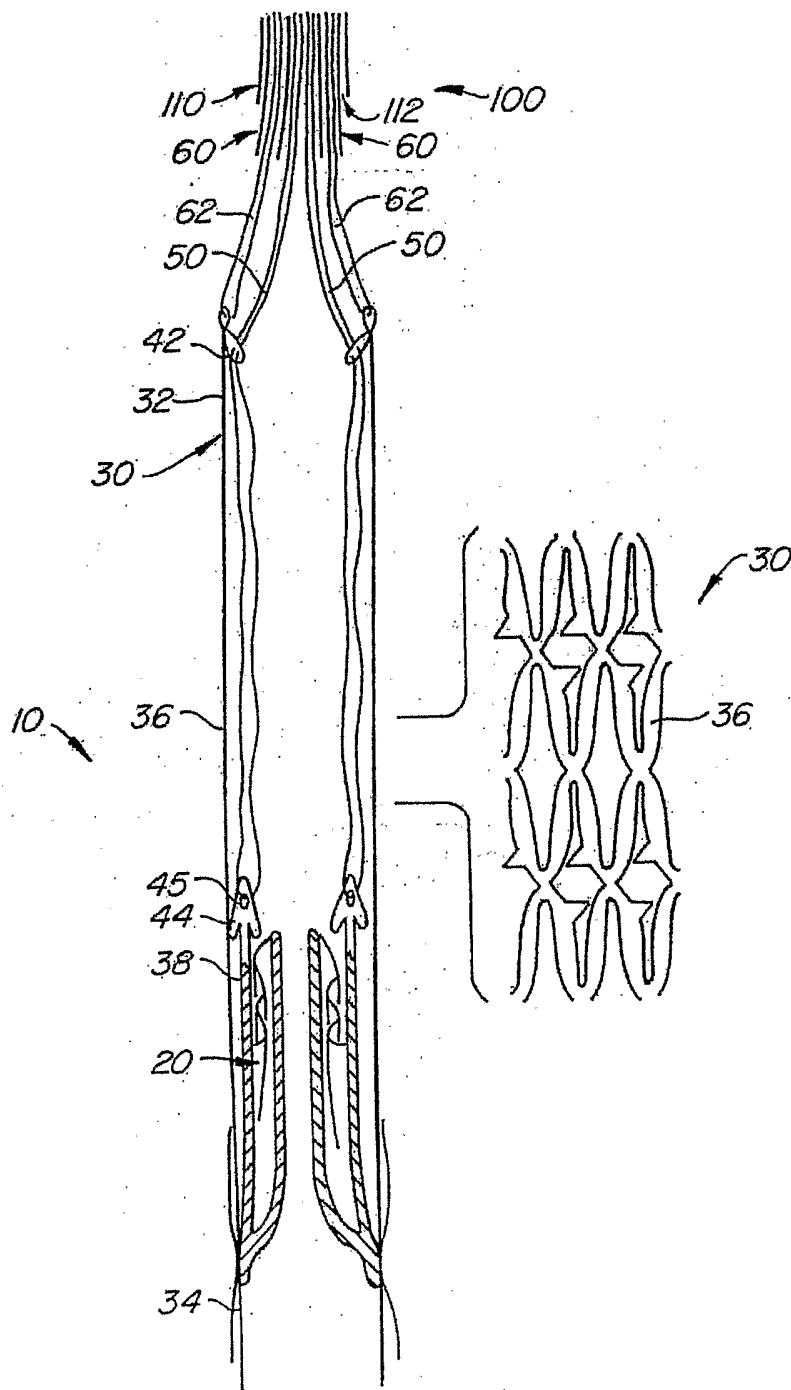

FIG. 3A

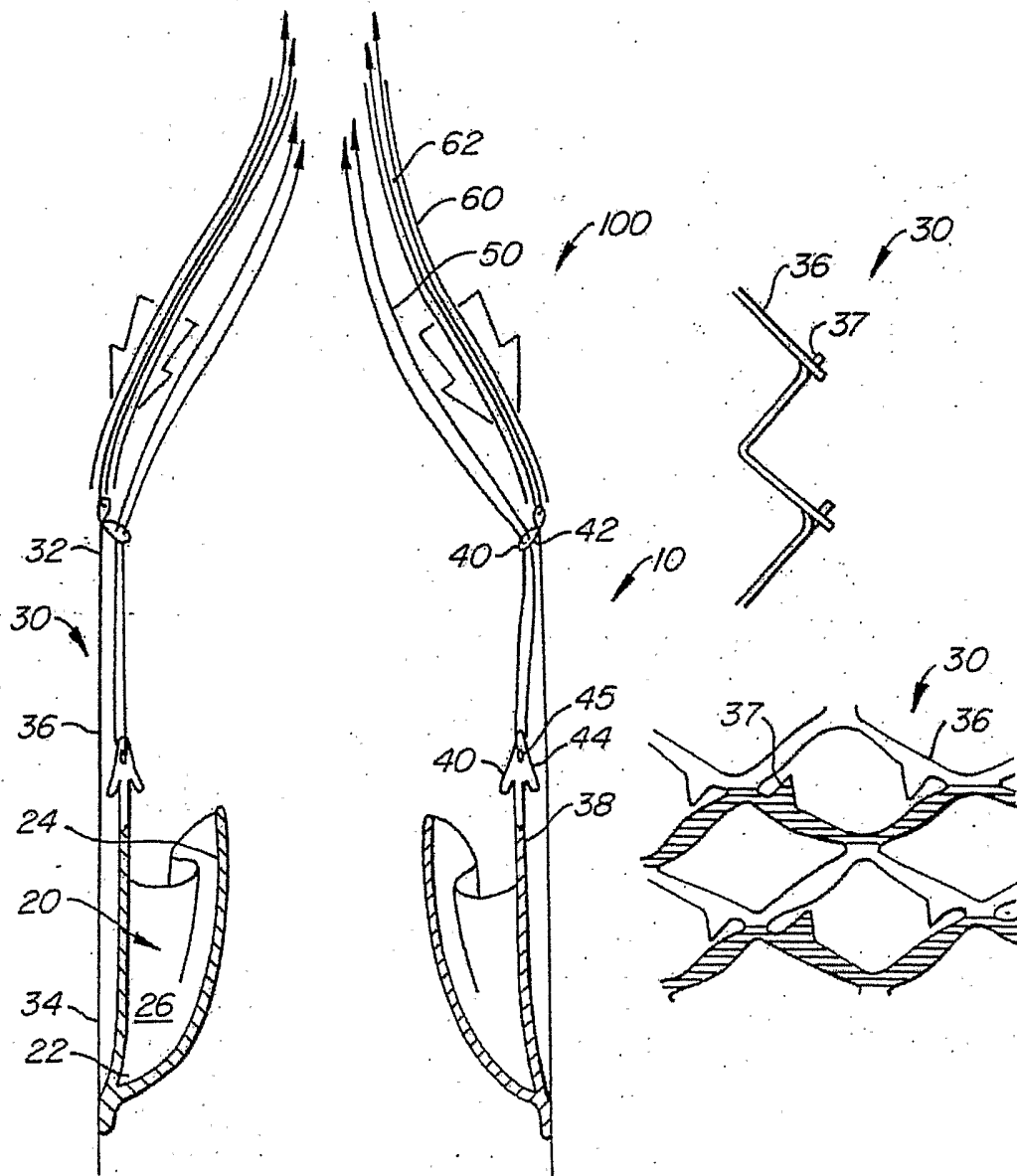

FIG. 3B

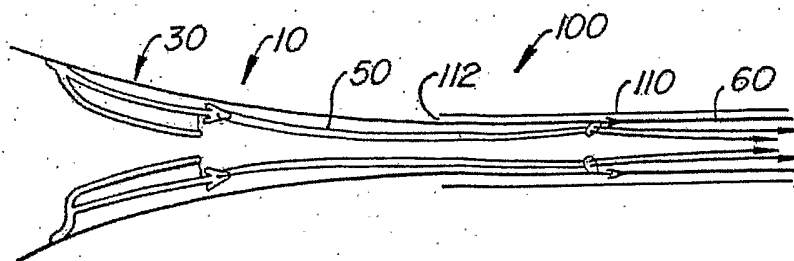

FIG. 4A

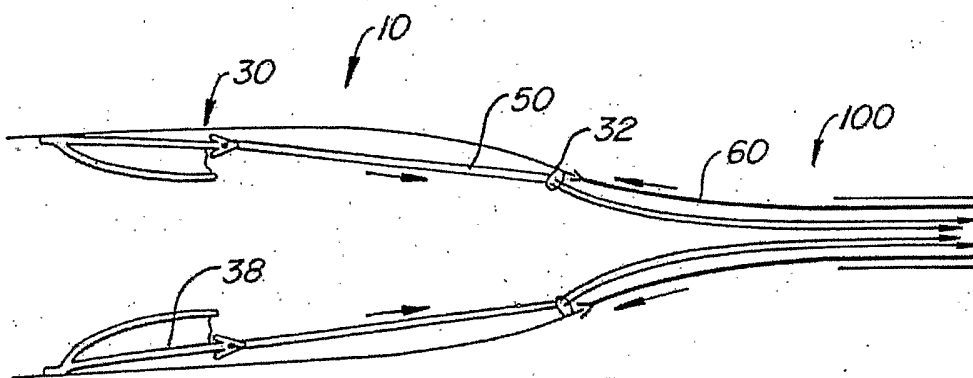

FIG. 4B

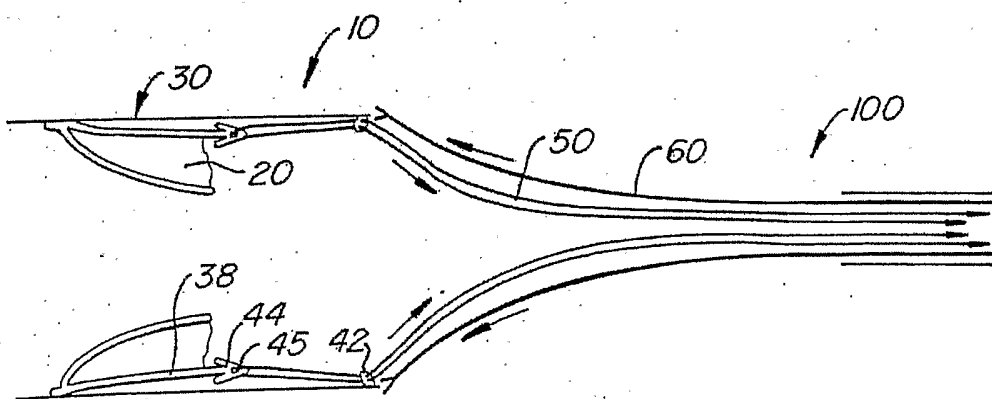

FIG. 4C

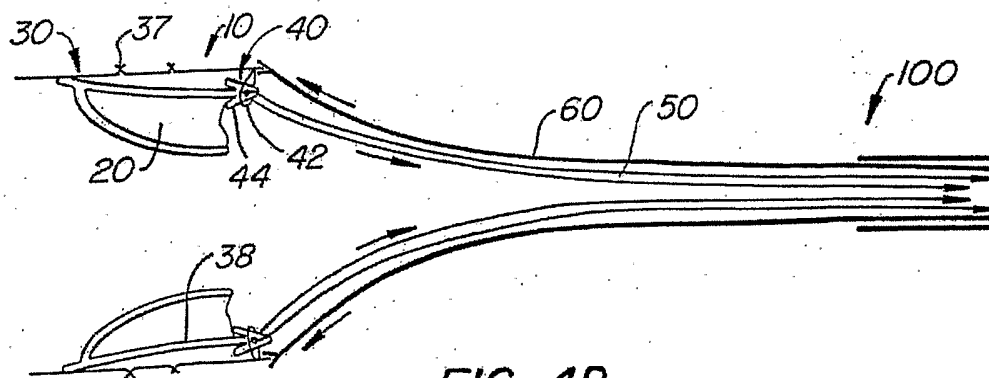

FIG. 4D

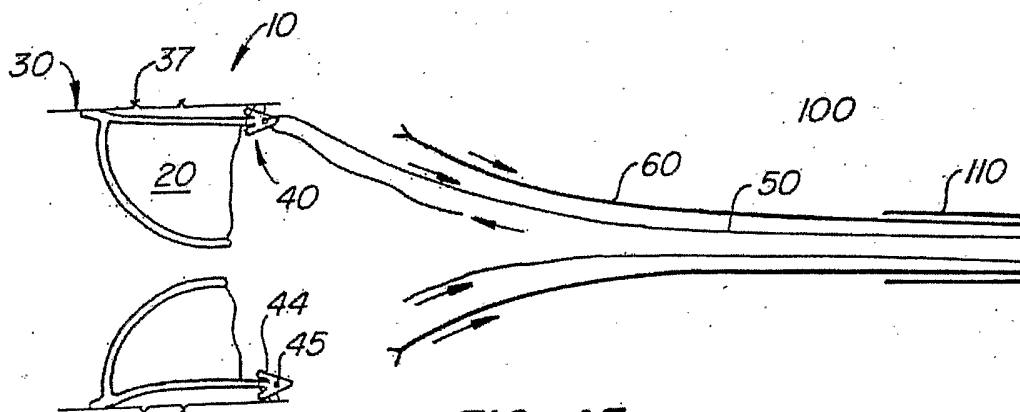

FIG. 4E

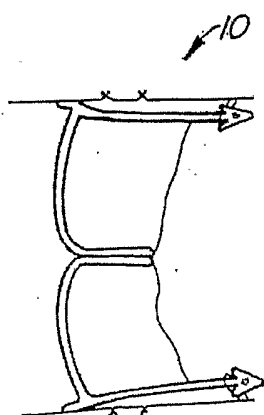

FIG. 4F

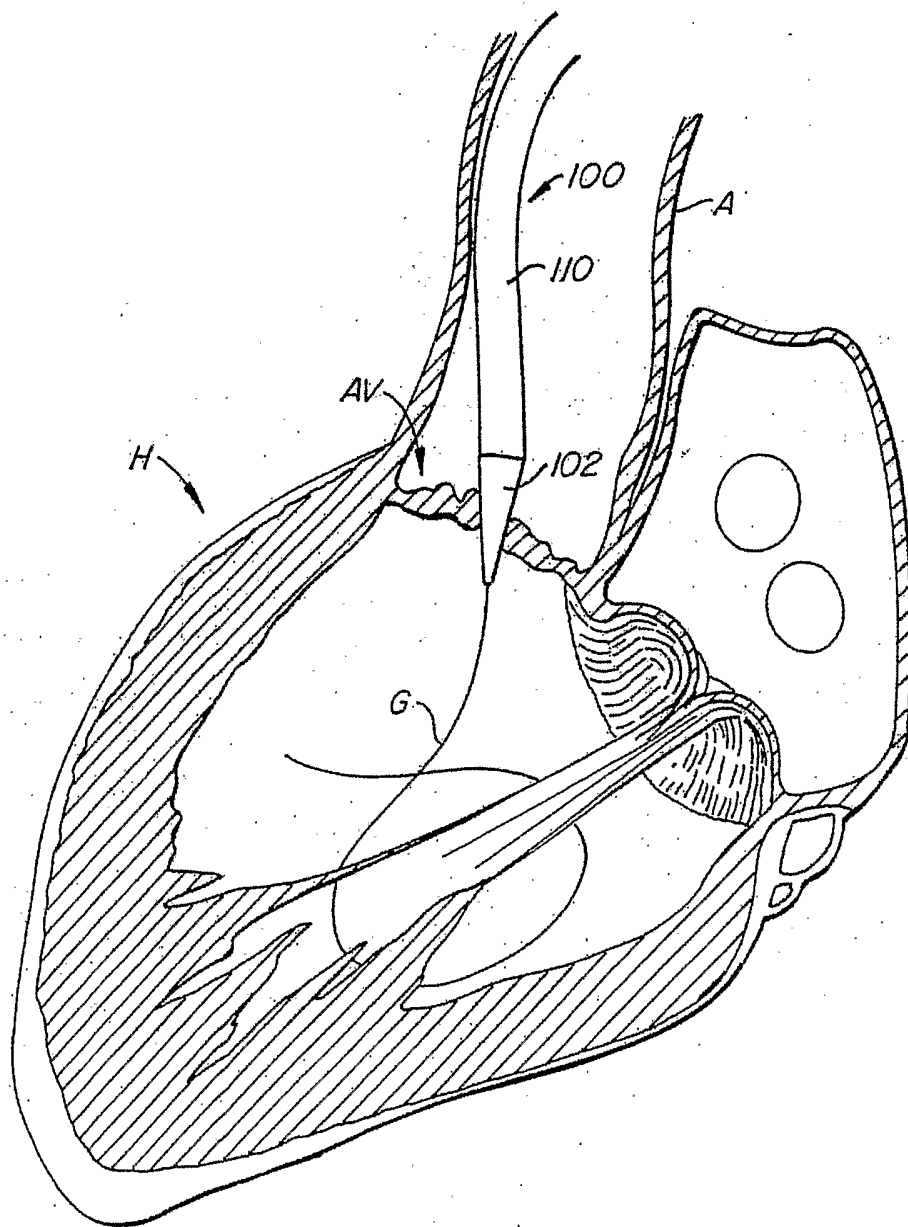

FIG. 5A

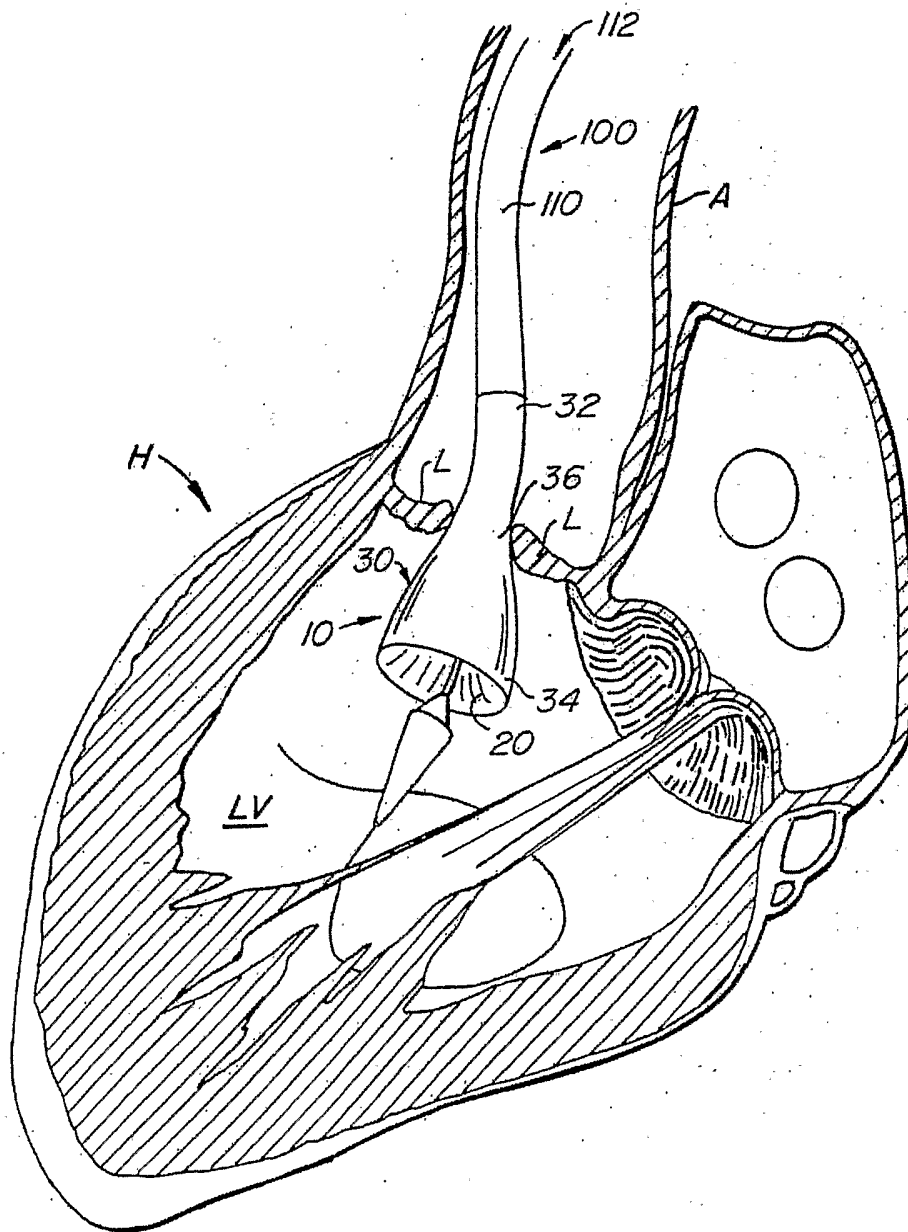

FIG. 5B

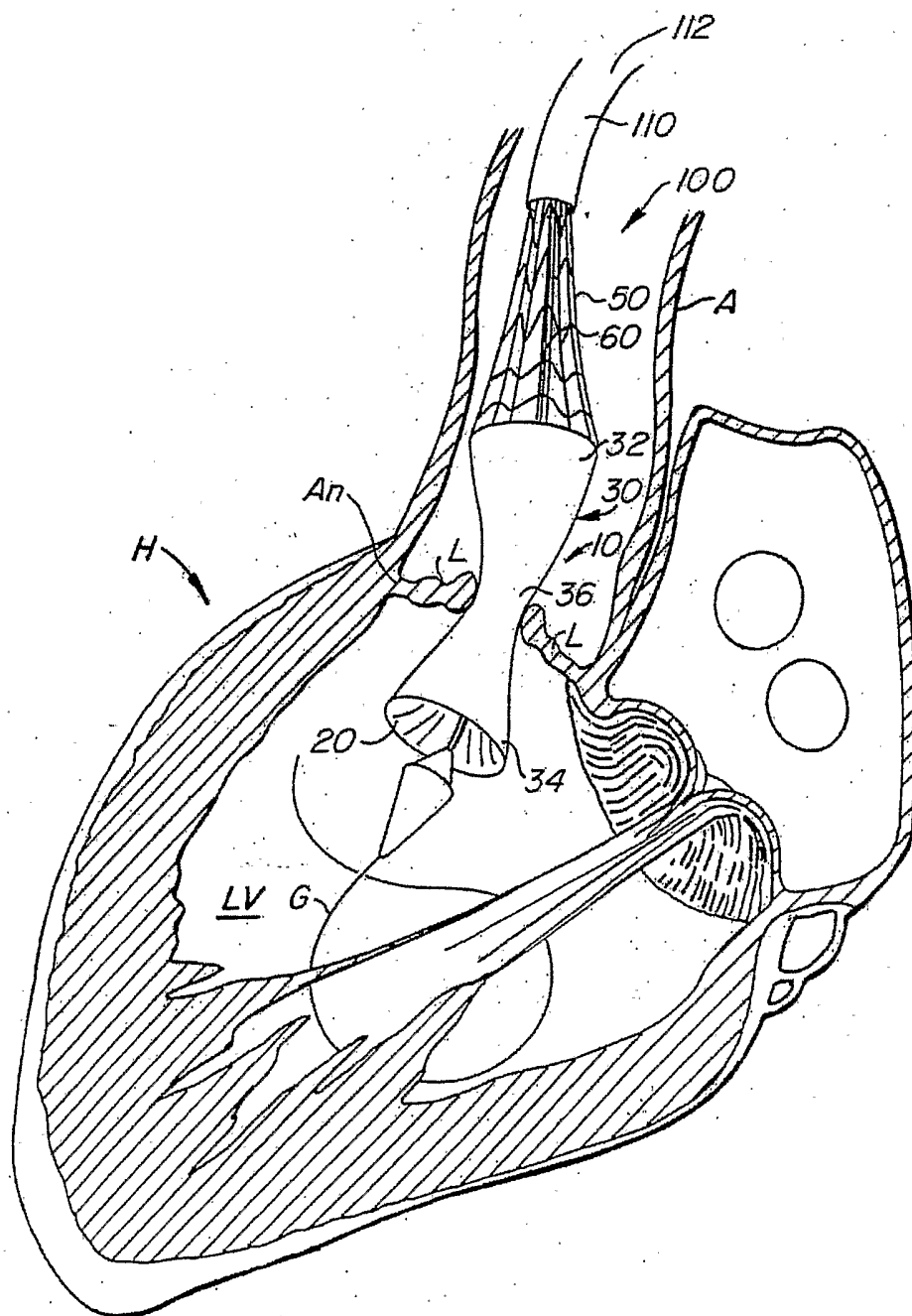

FIG. 5C

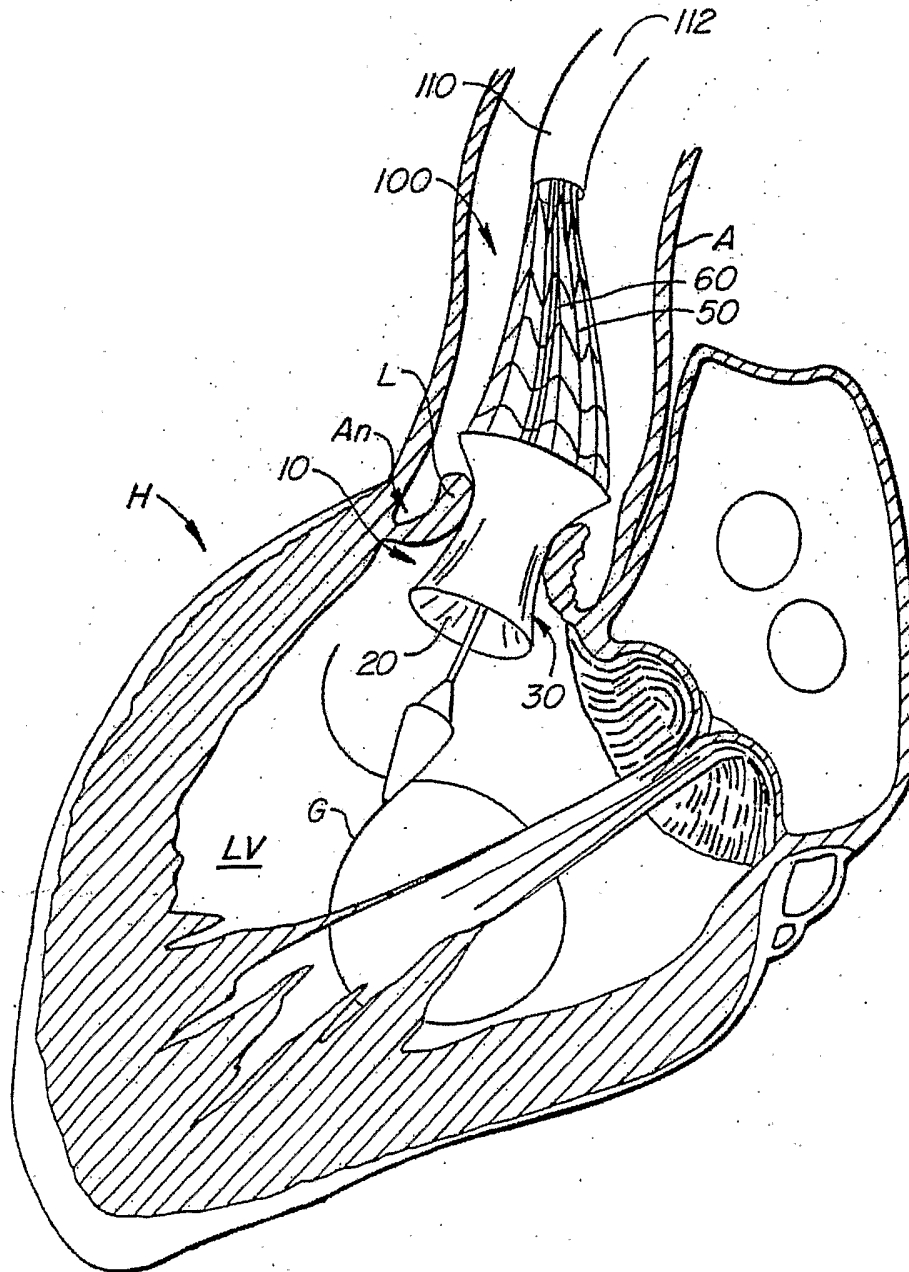

FIG. 5D

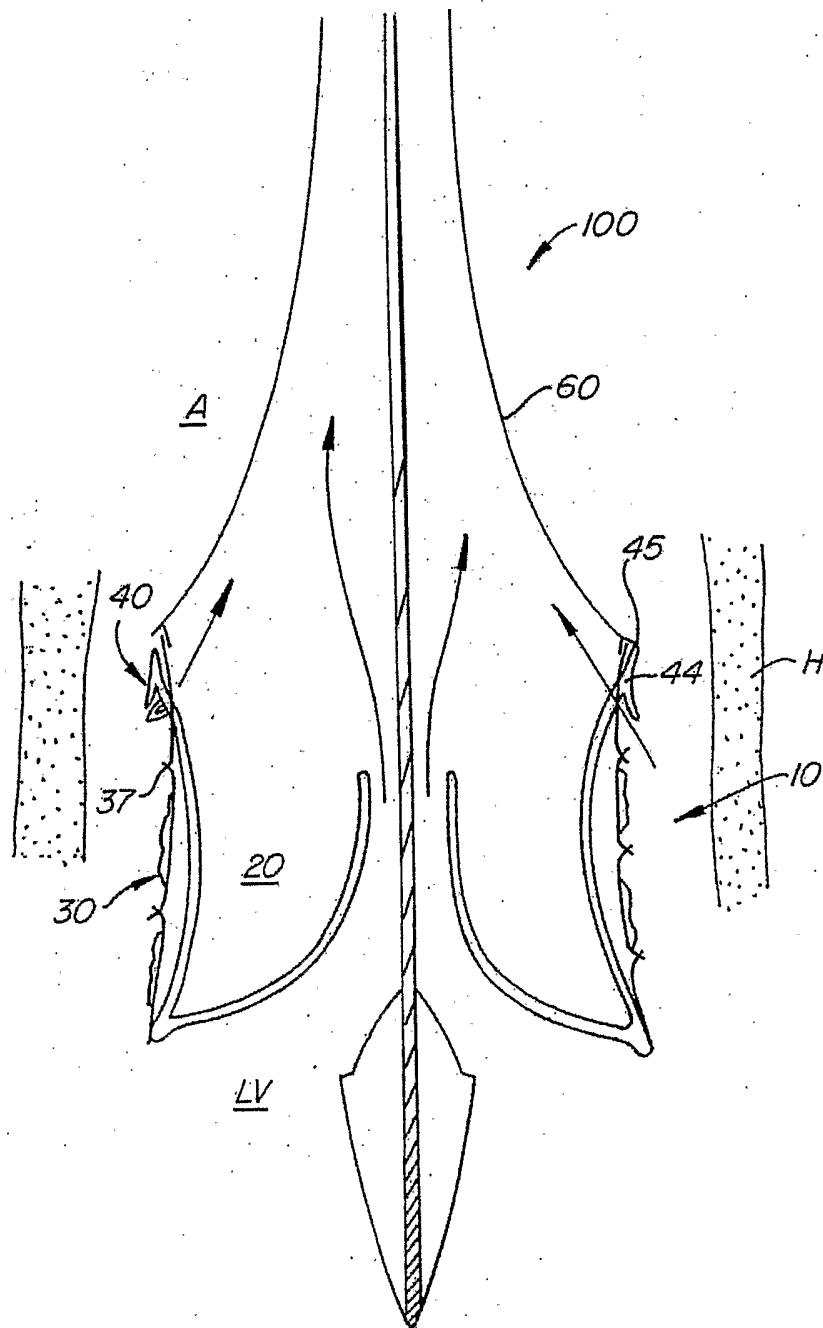

FIG. 5E

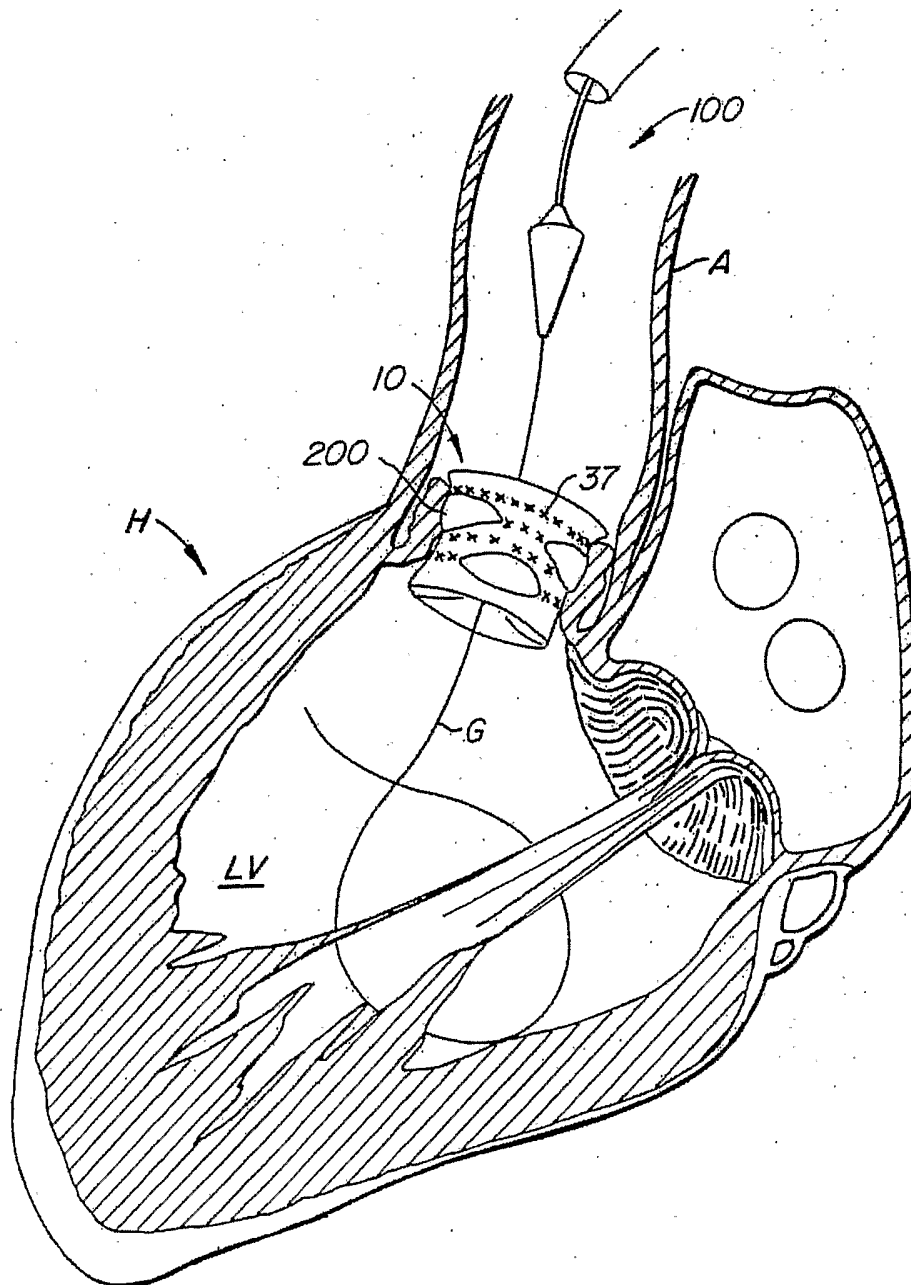

FIG. 5F

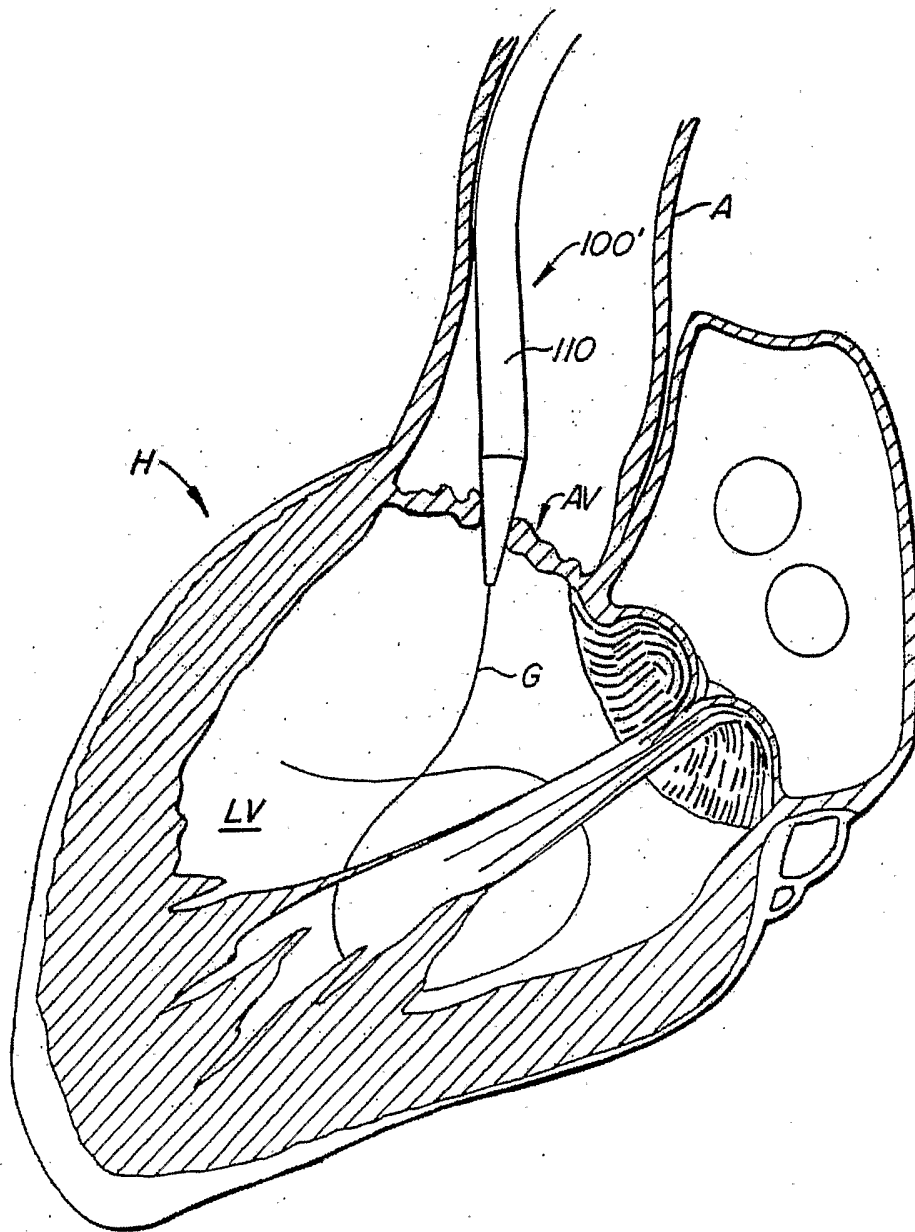

FIG. 6A

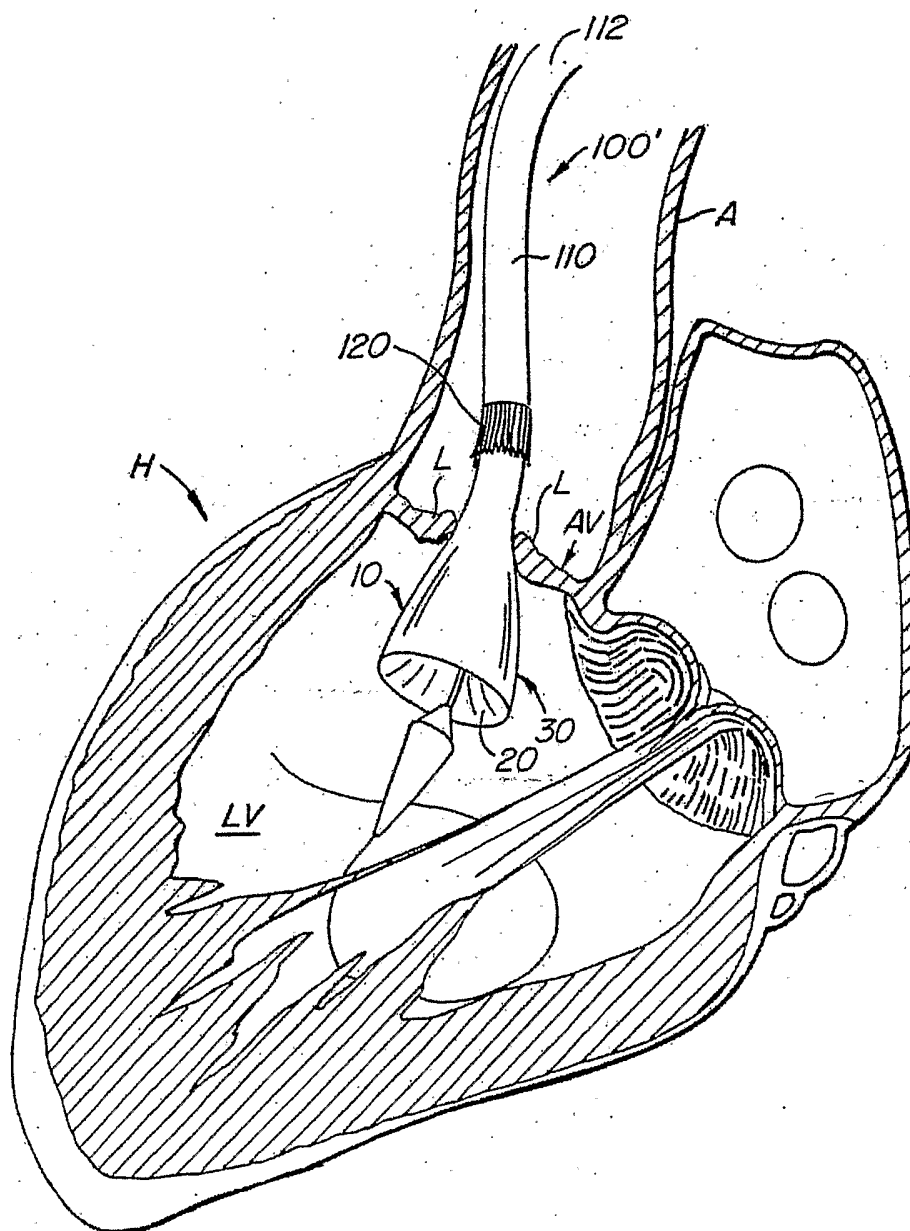

FIG. 6B

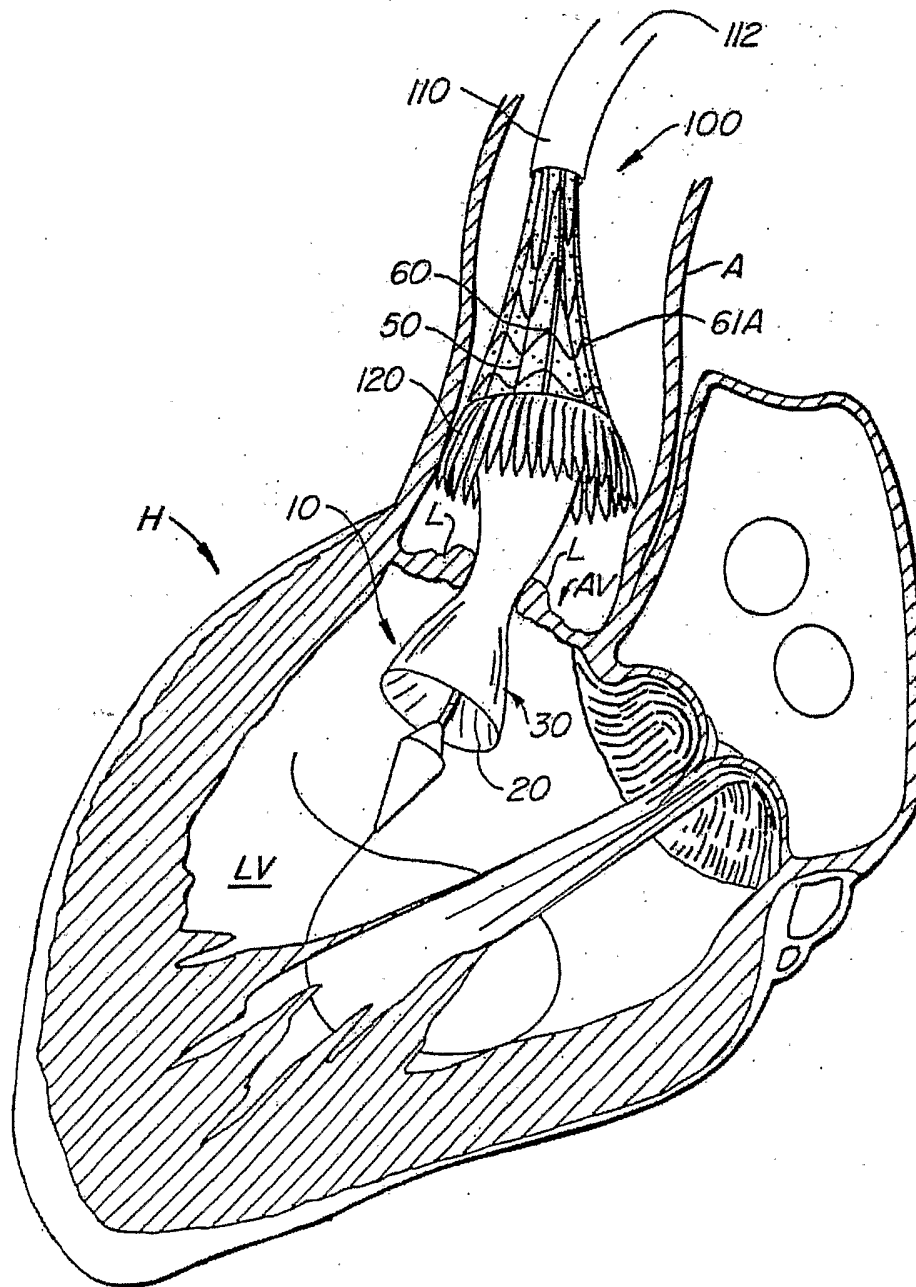

FIG. 6C

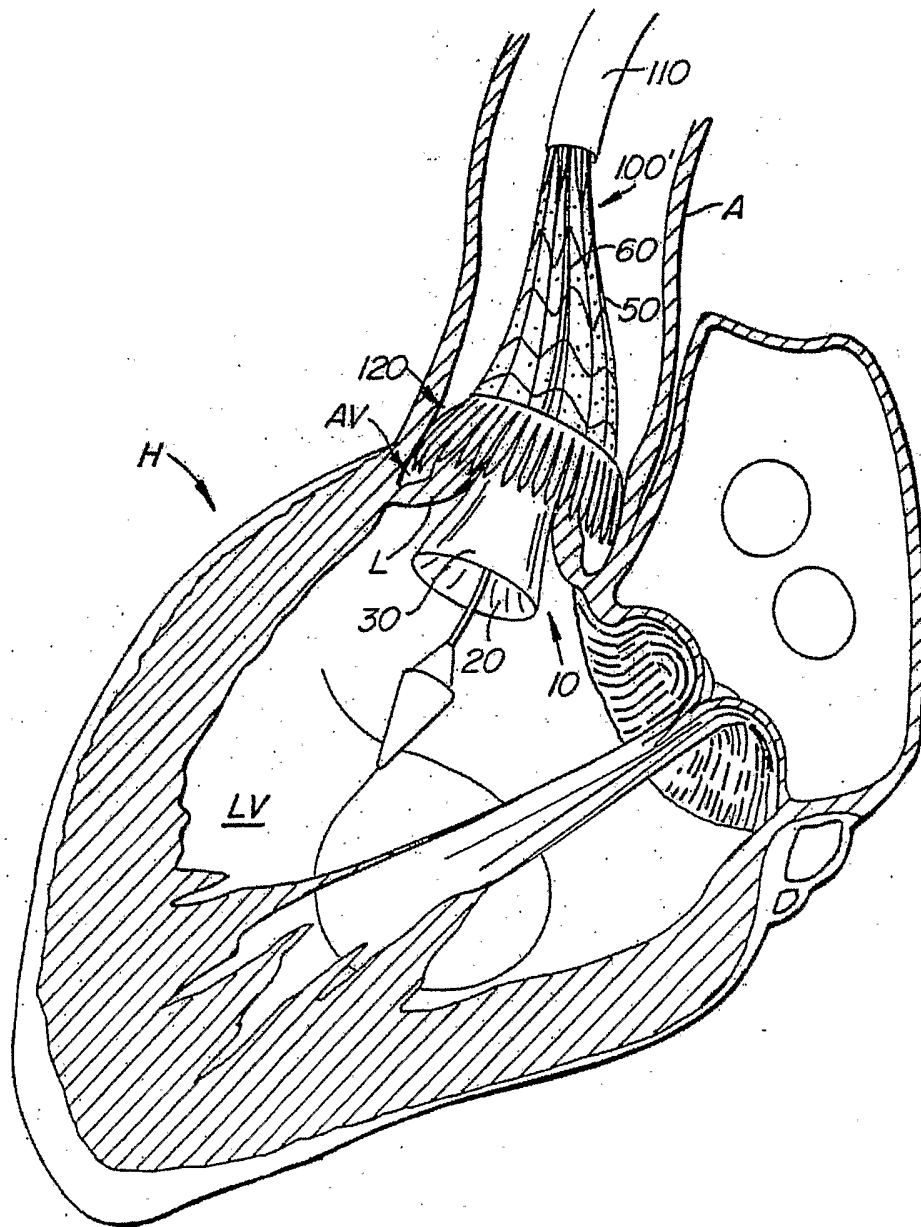

FIG. 6D

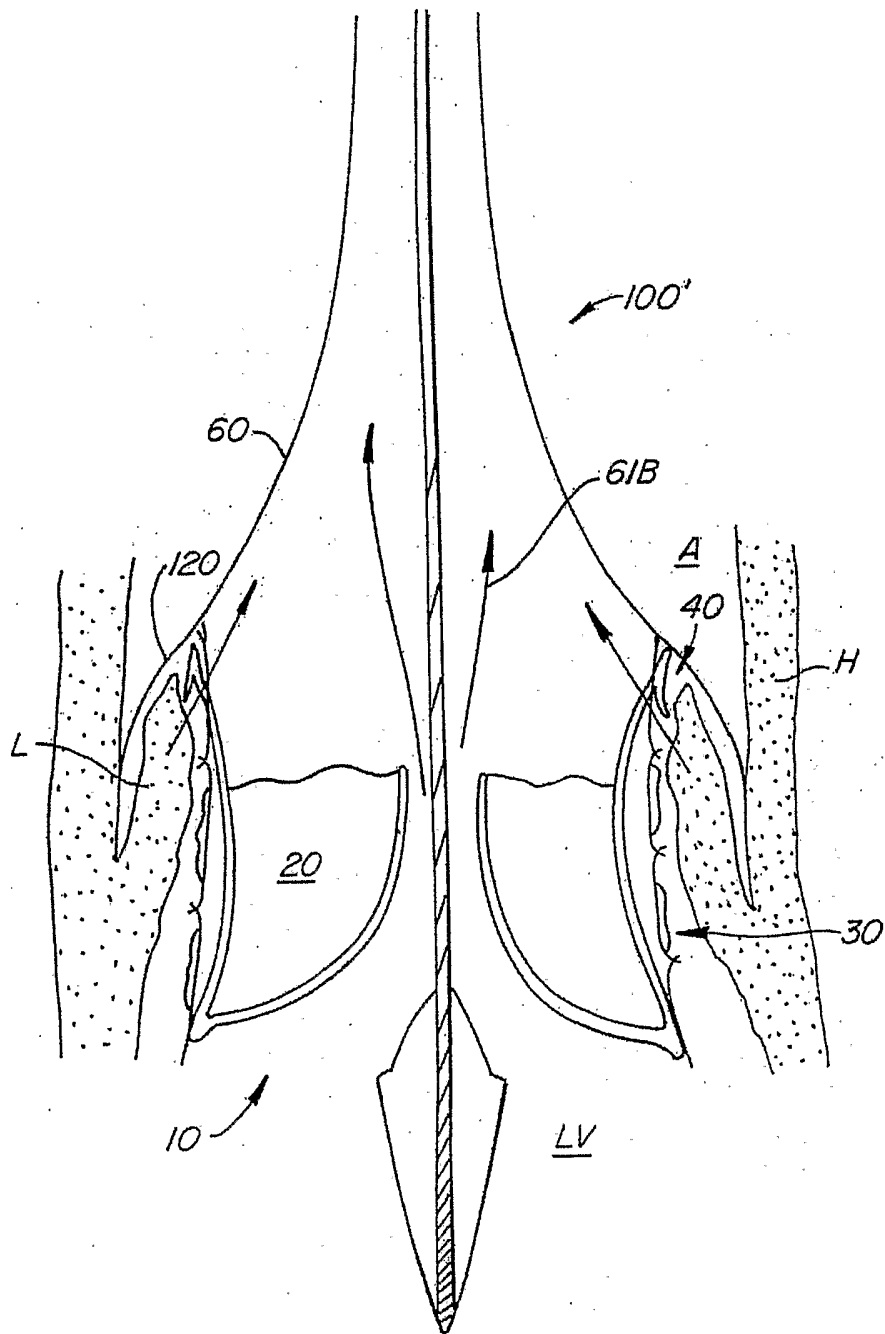

FIG. 6E

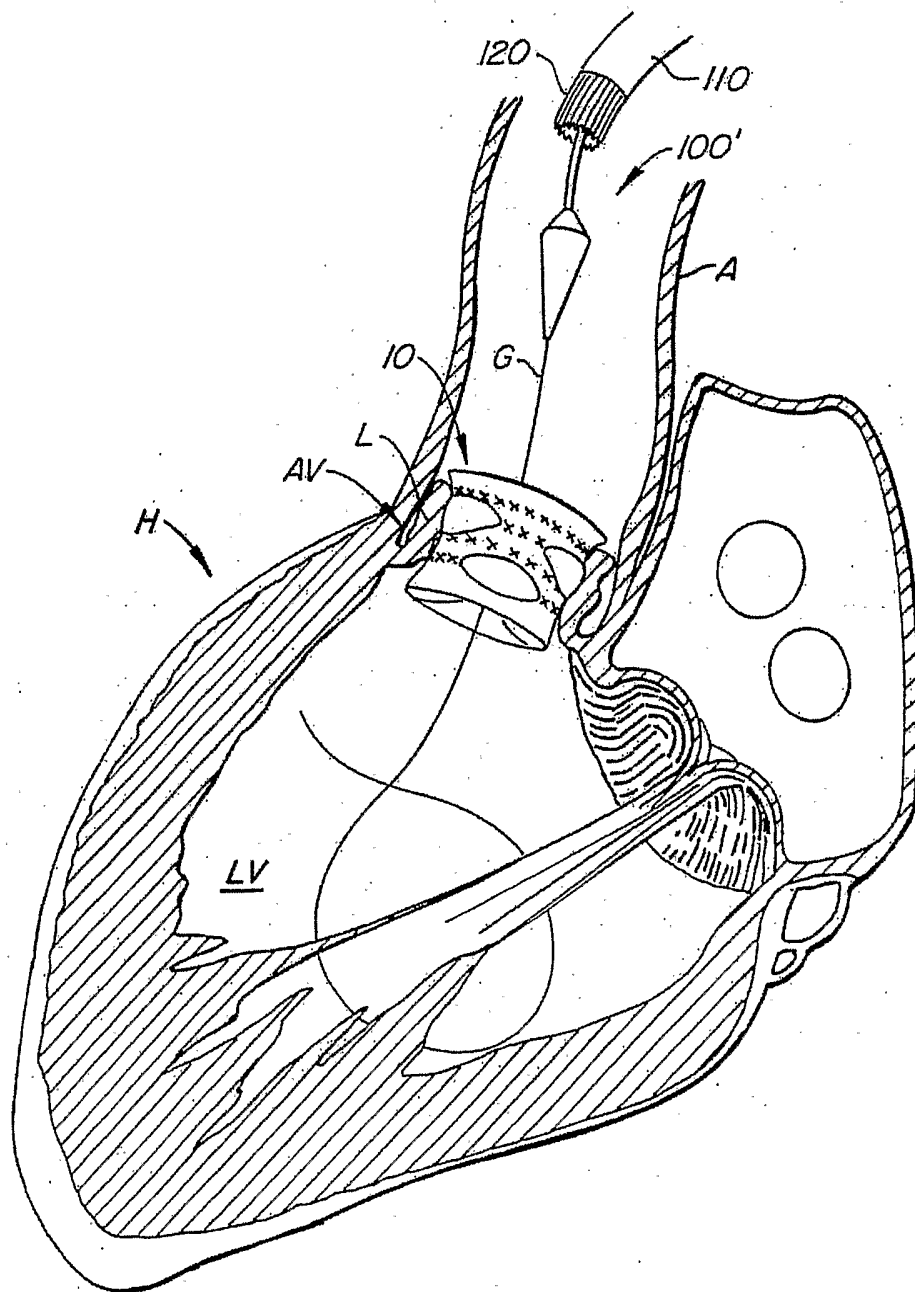

FIG. 6F

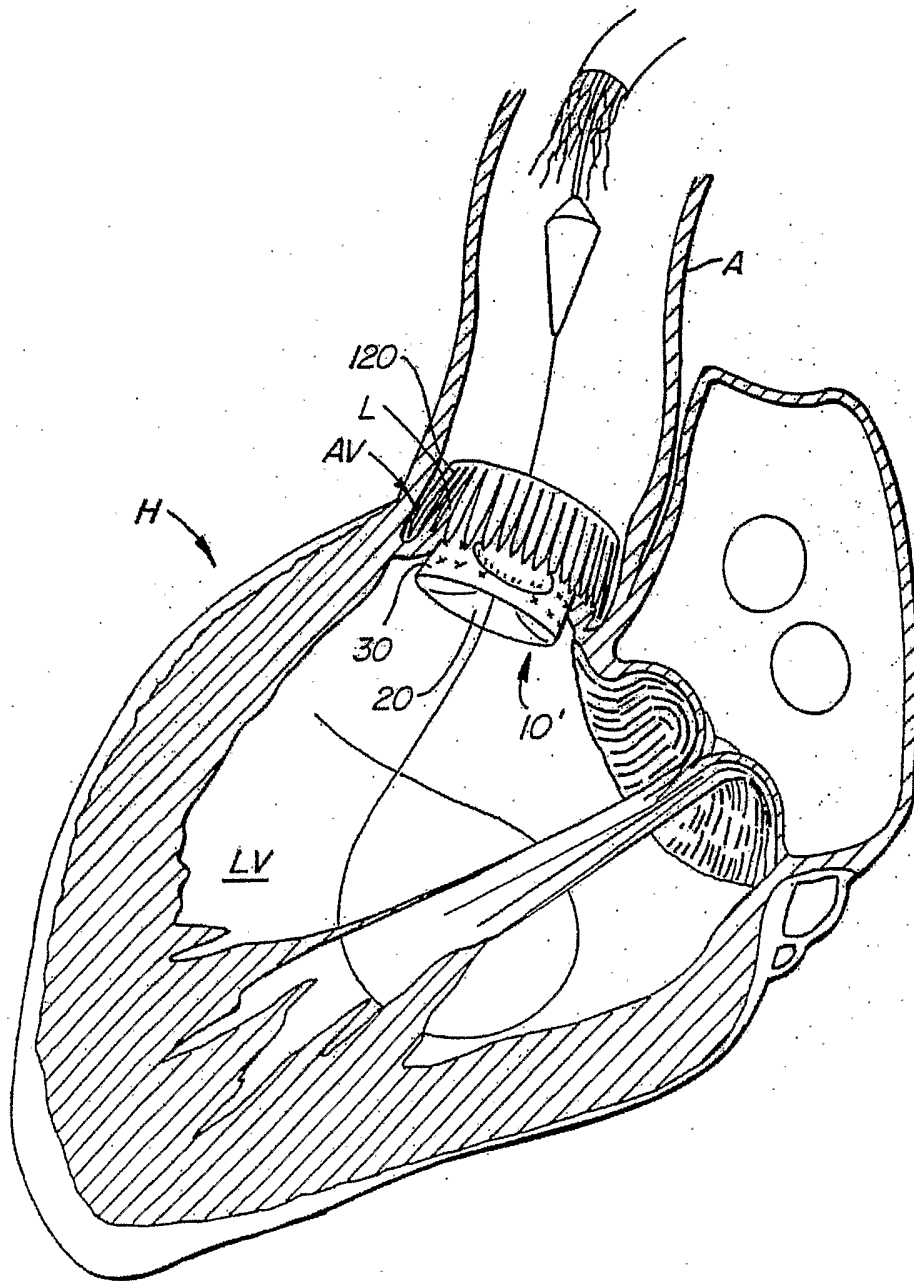
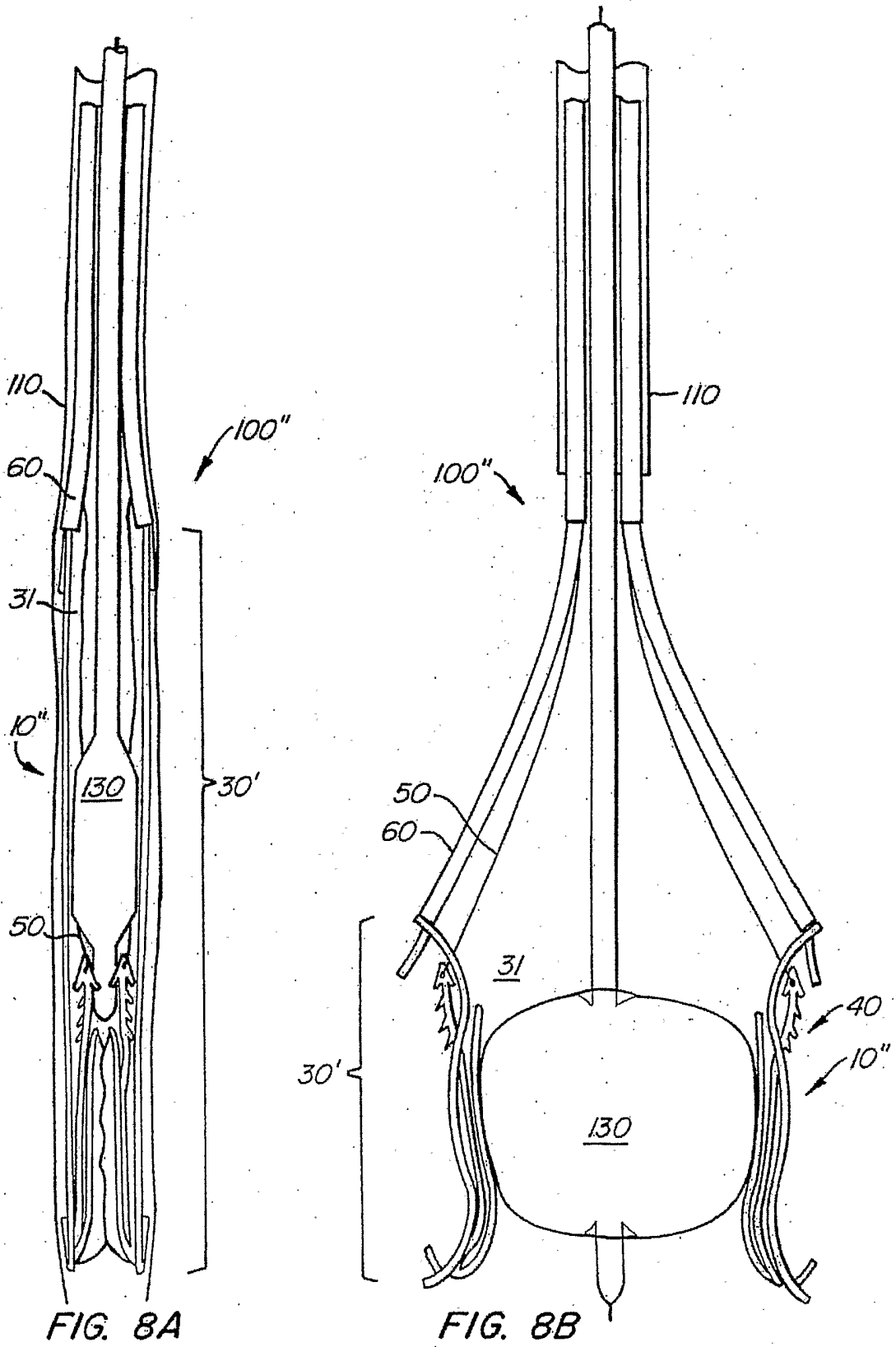

FIG. 7



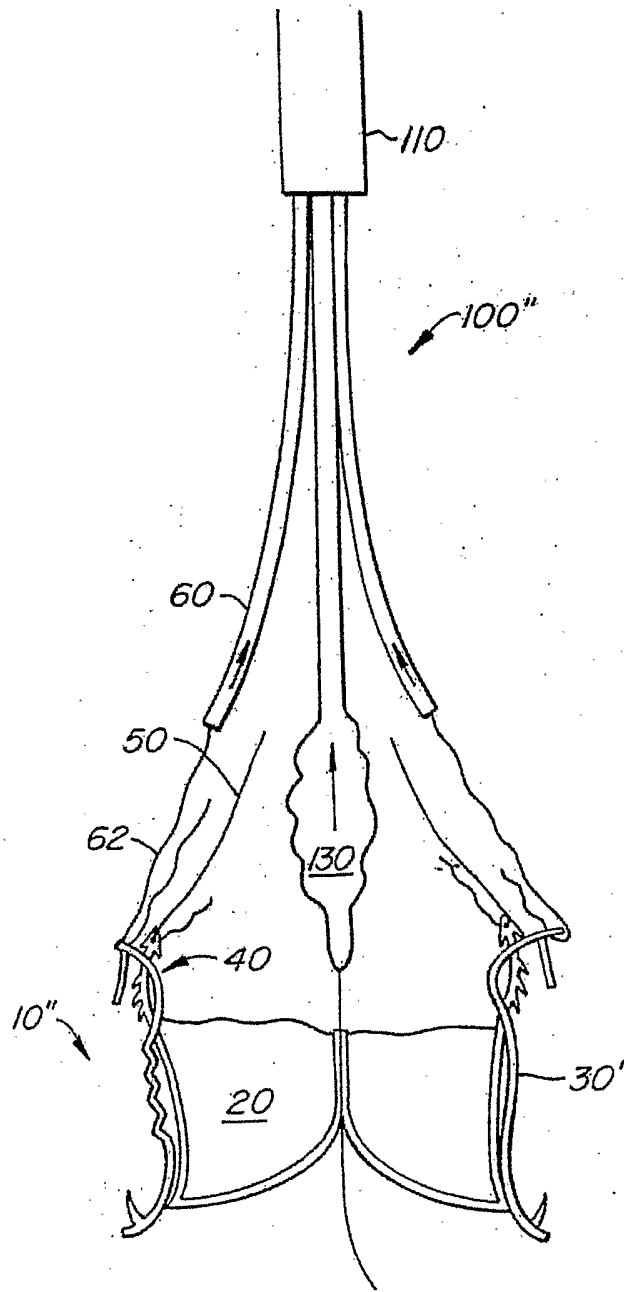

FIG. 8C

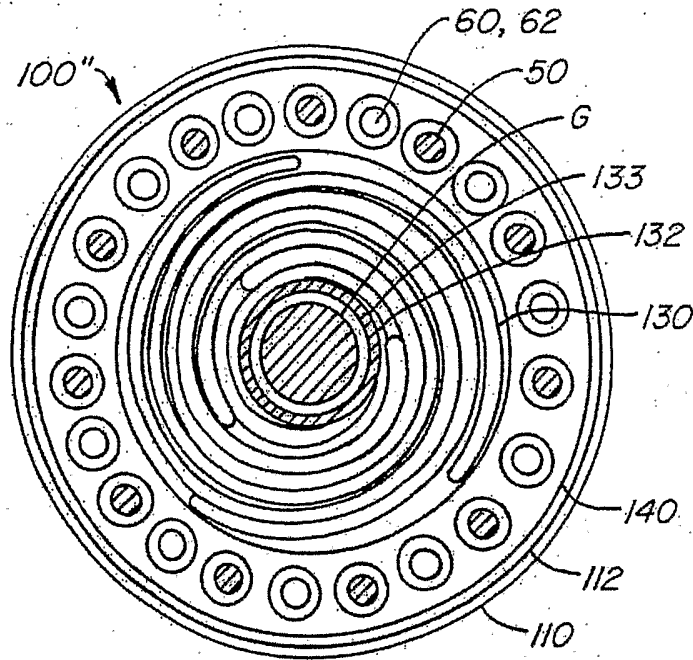

FIG. 10

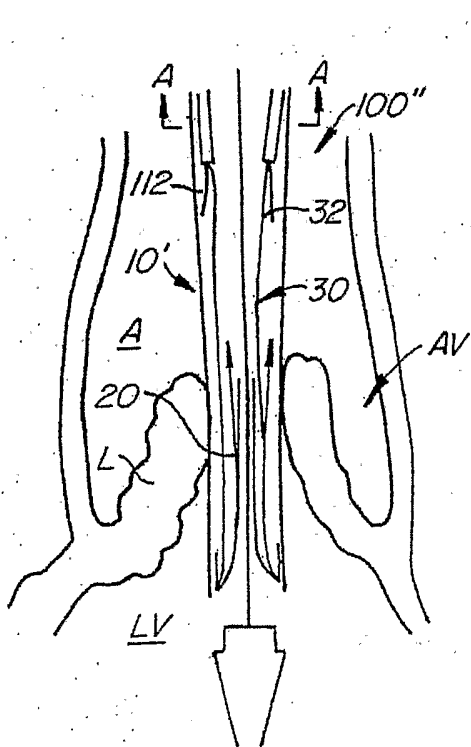

FIG. 9A

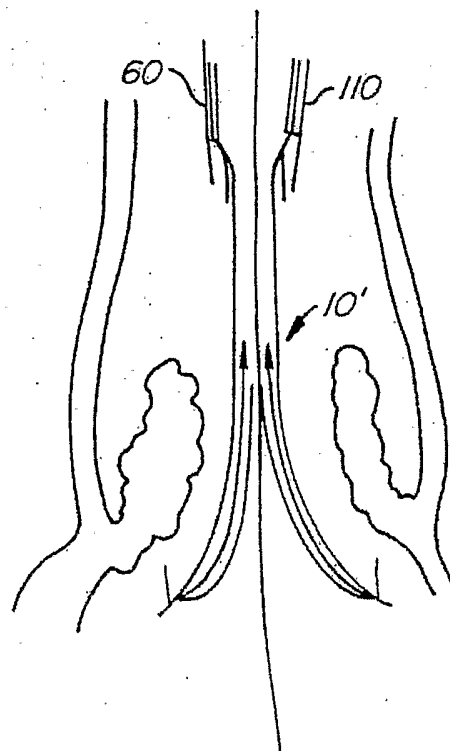

FIG. 9B

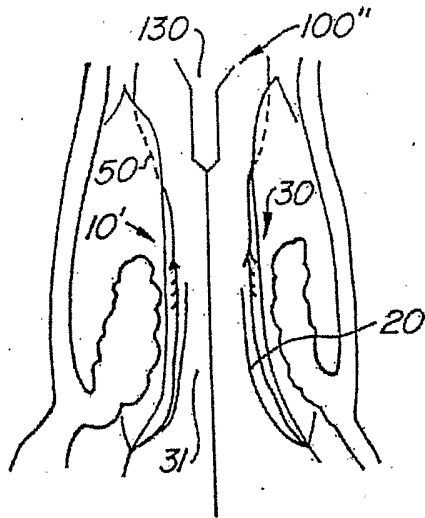

FIG. 9C

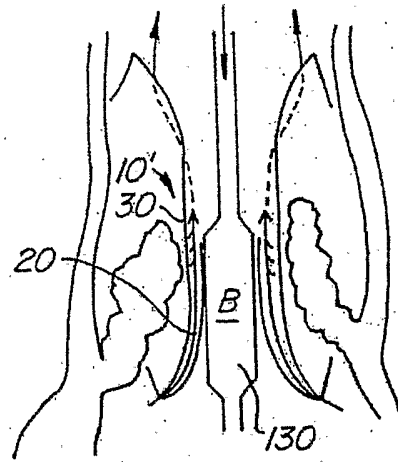

FIG. 9D

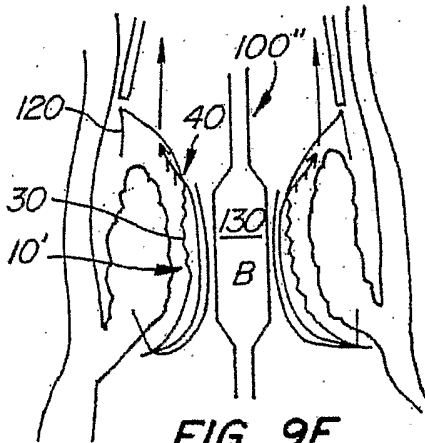

FIG. 9E

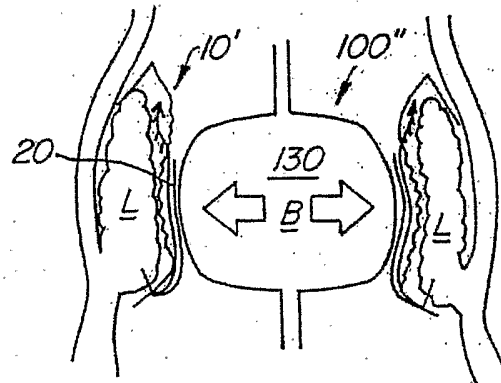

FIG. 9F

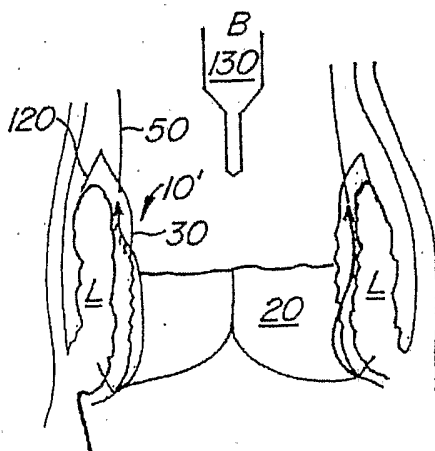

FIG. 9G

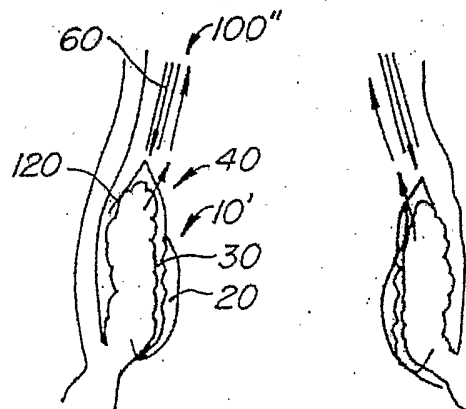

FIG. 9H

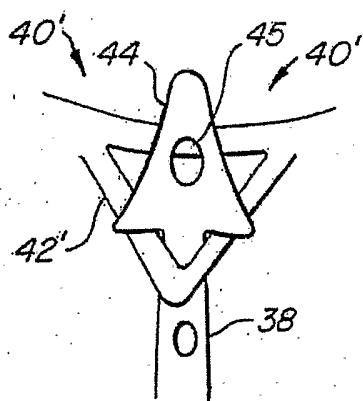

FIG. IIA

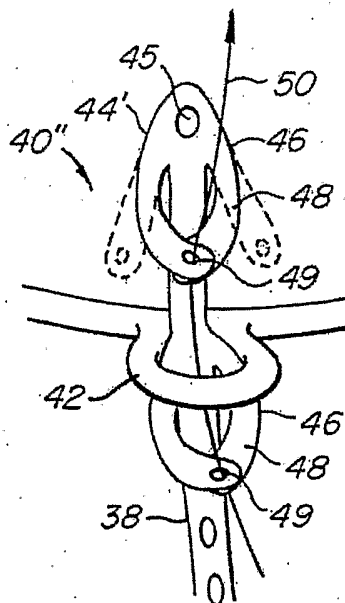

FIG. IIB

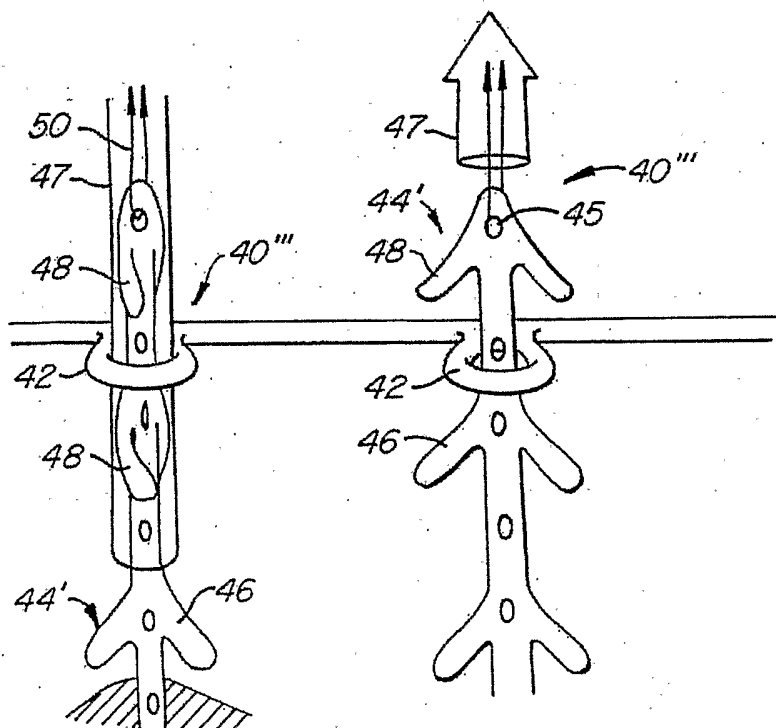

FIG. IIC

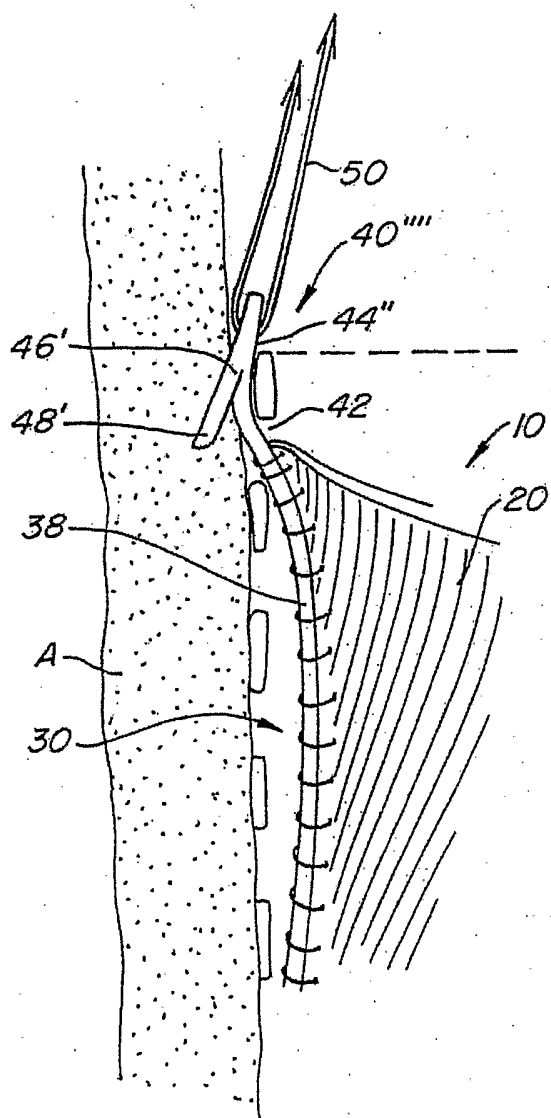

FIG. 12C

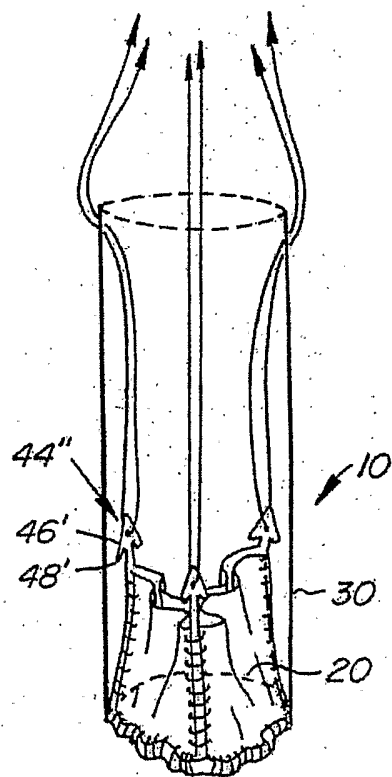

FIG. 12A

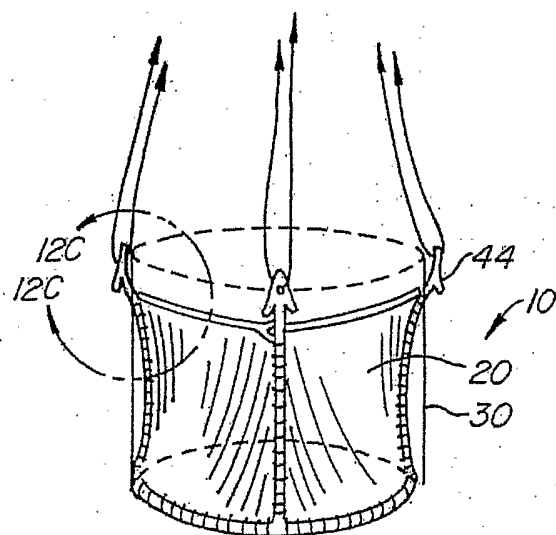

FIG. 12B

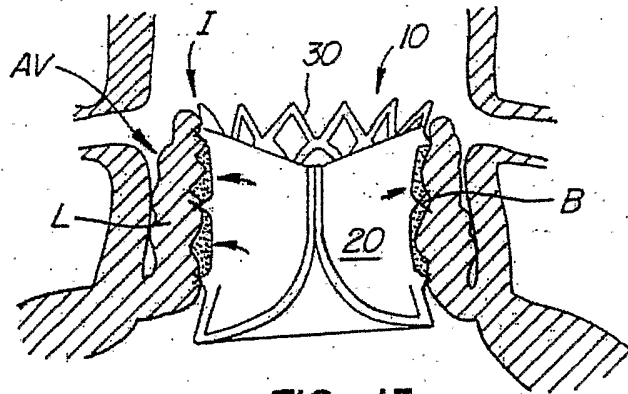

FIG. 13

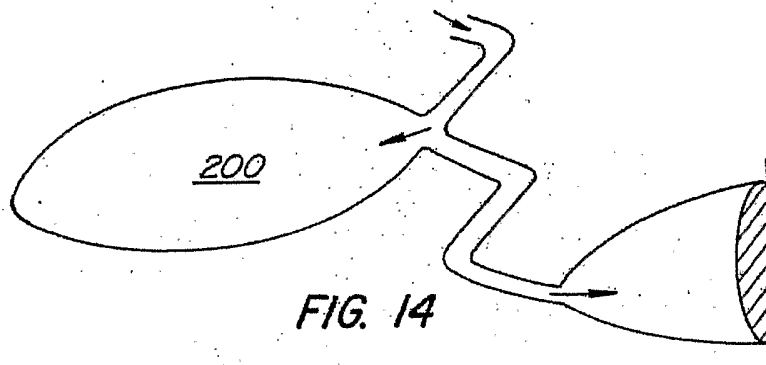

FIG. 14

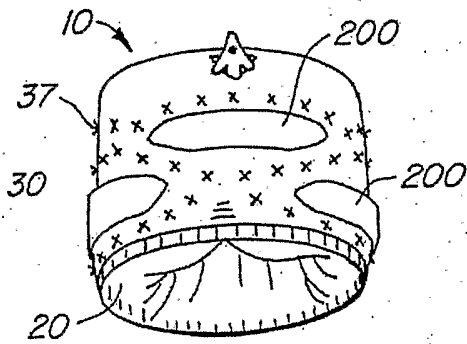

FIG. 15A

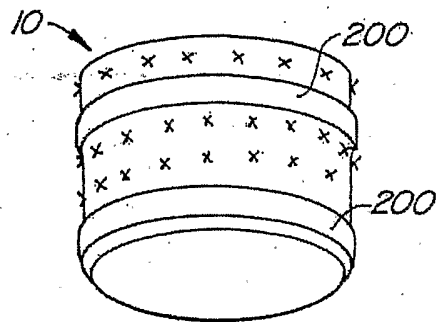

FIG. 15B

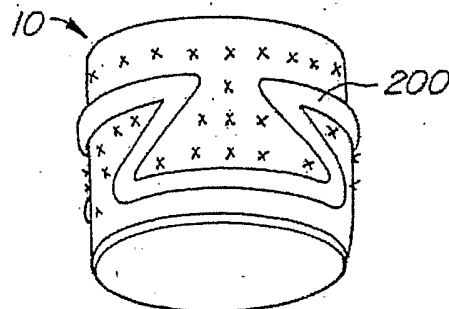

FIG. 15C

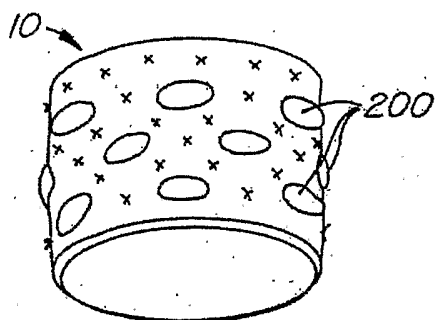

FIG. 15D

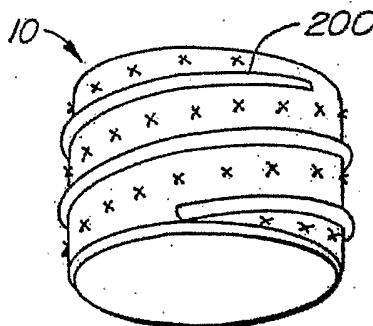

FIG. 15E

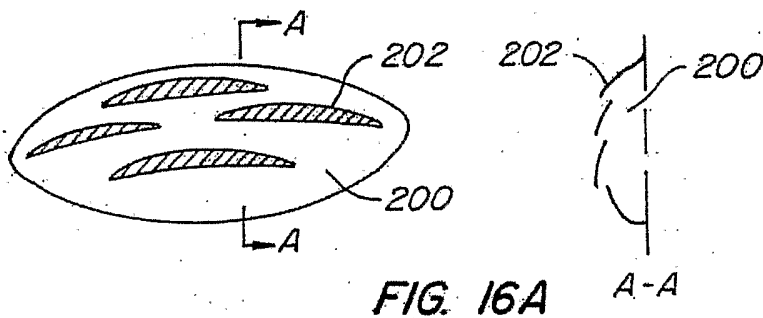

FIG. 16A

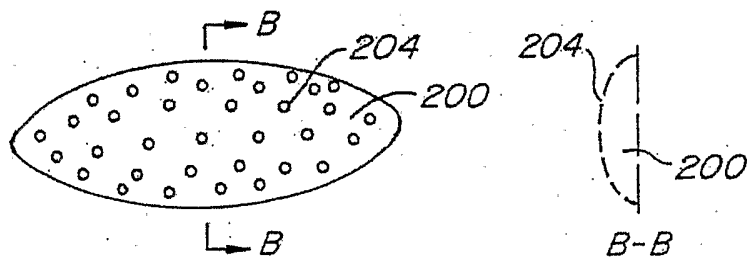

FIG. 16B

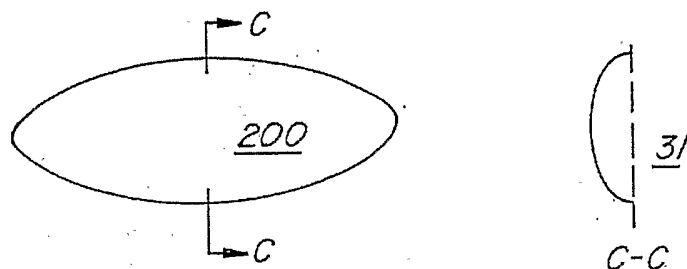

FIG. 16C

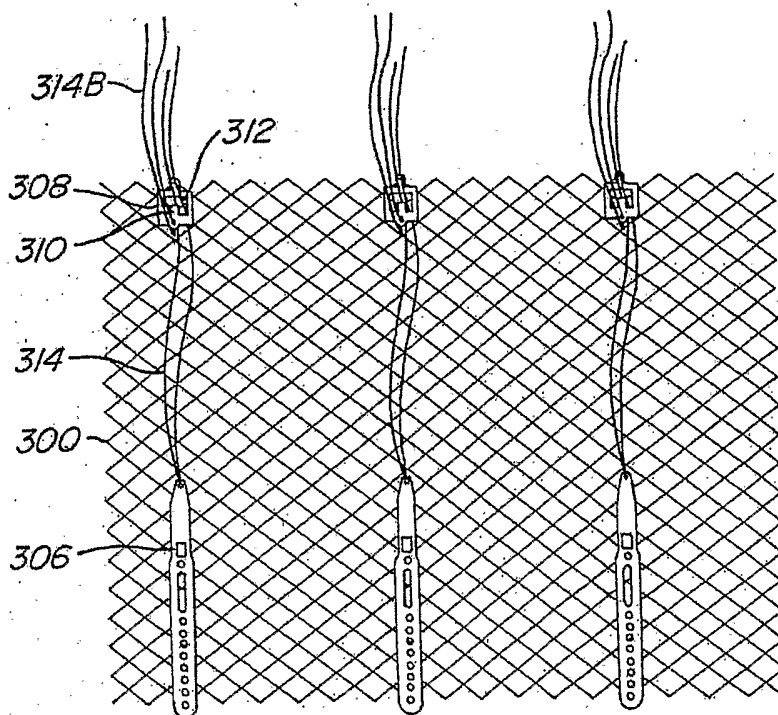

FIG. 17A

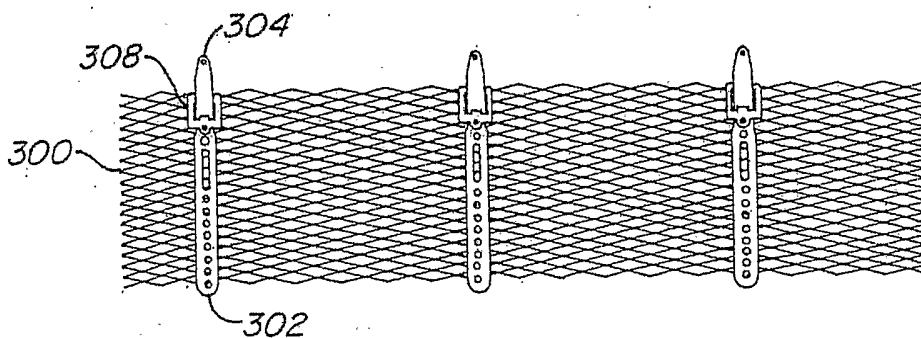

FIG. 18A

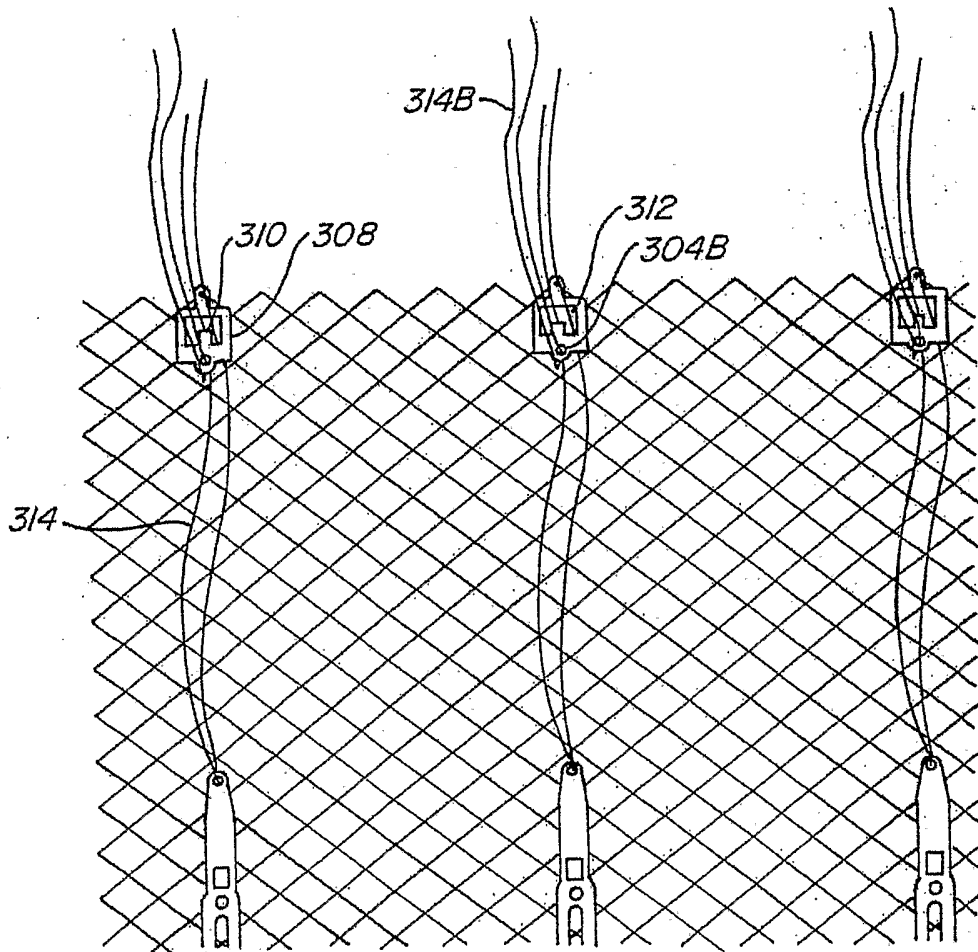

FIG. 17B

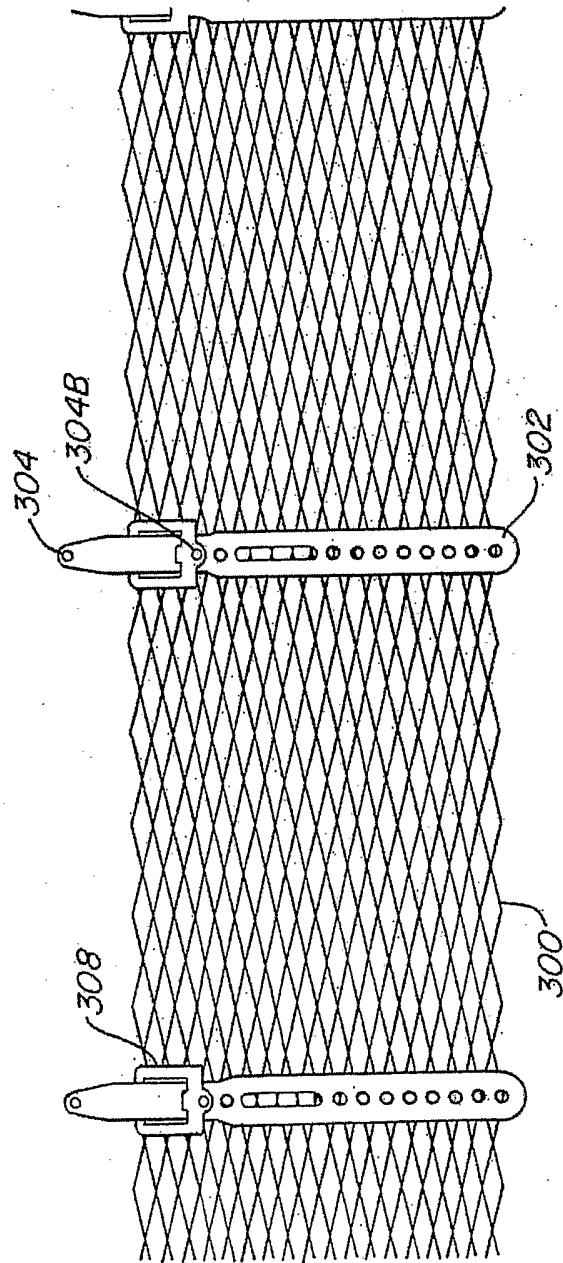

FIG. 18B

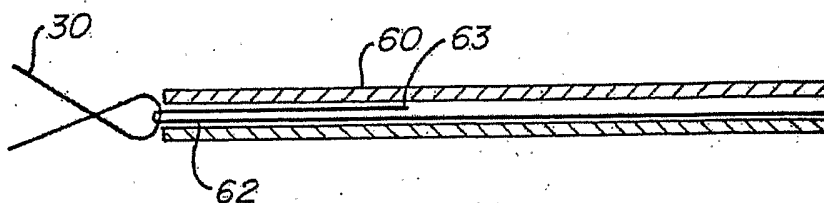

FIG. 19

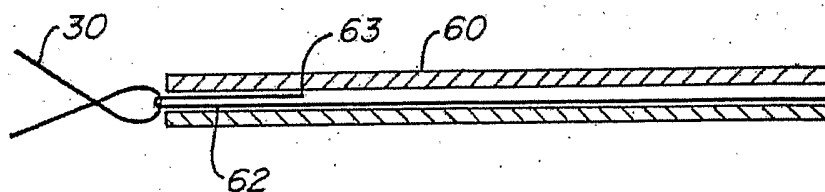

FIG. 20

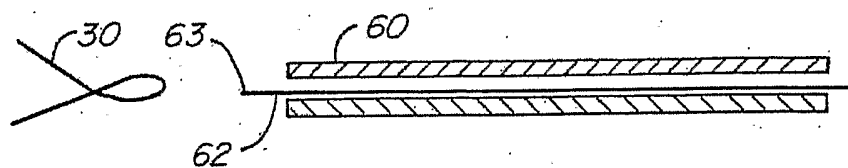

FIG. 21

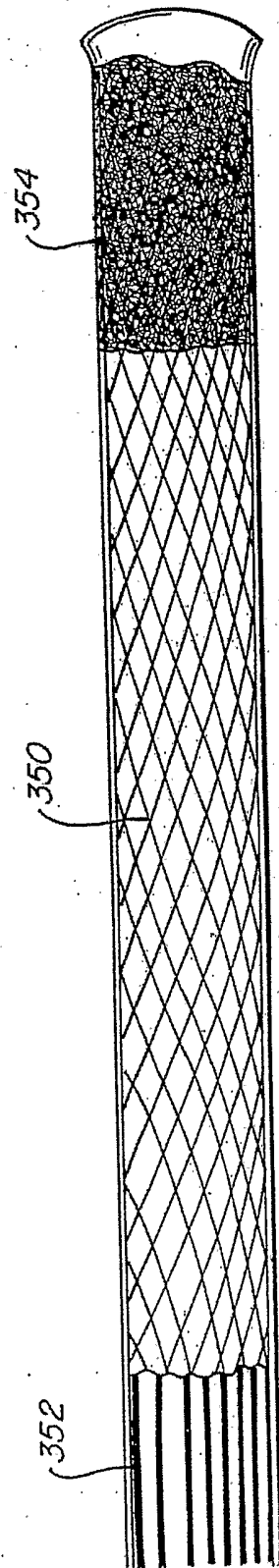

FIG. 22

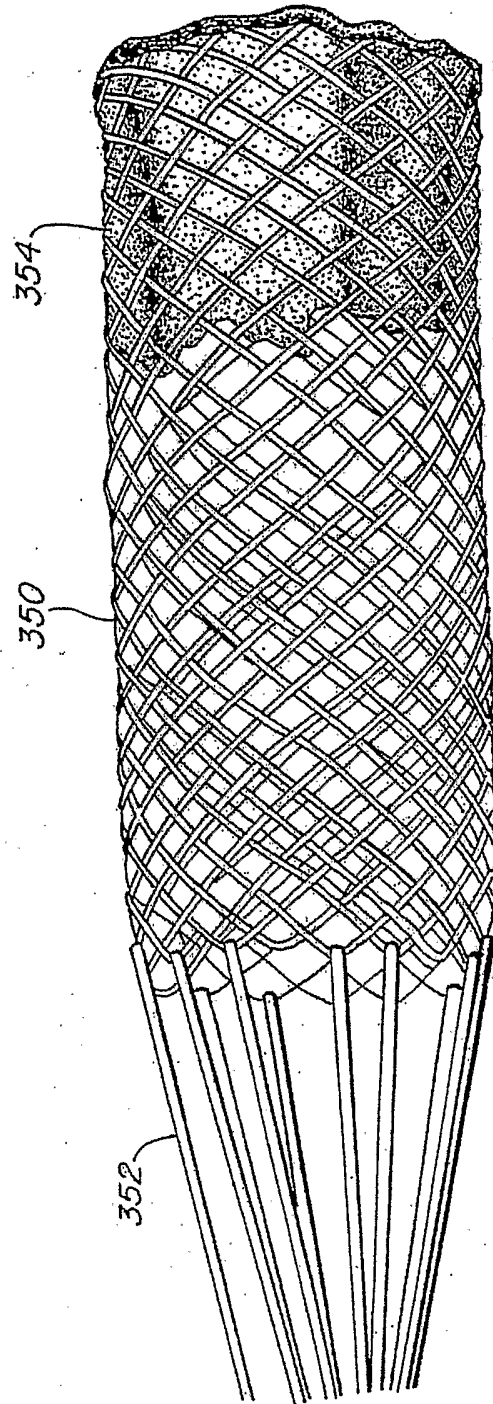

FIG. 23

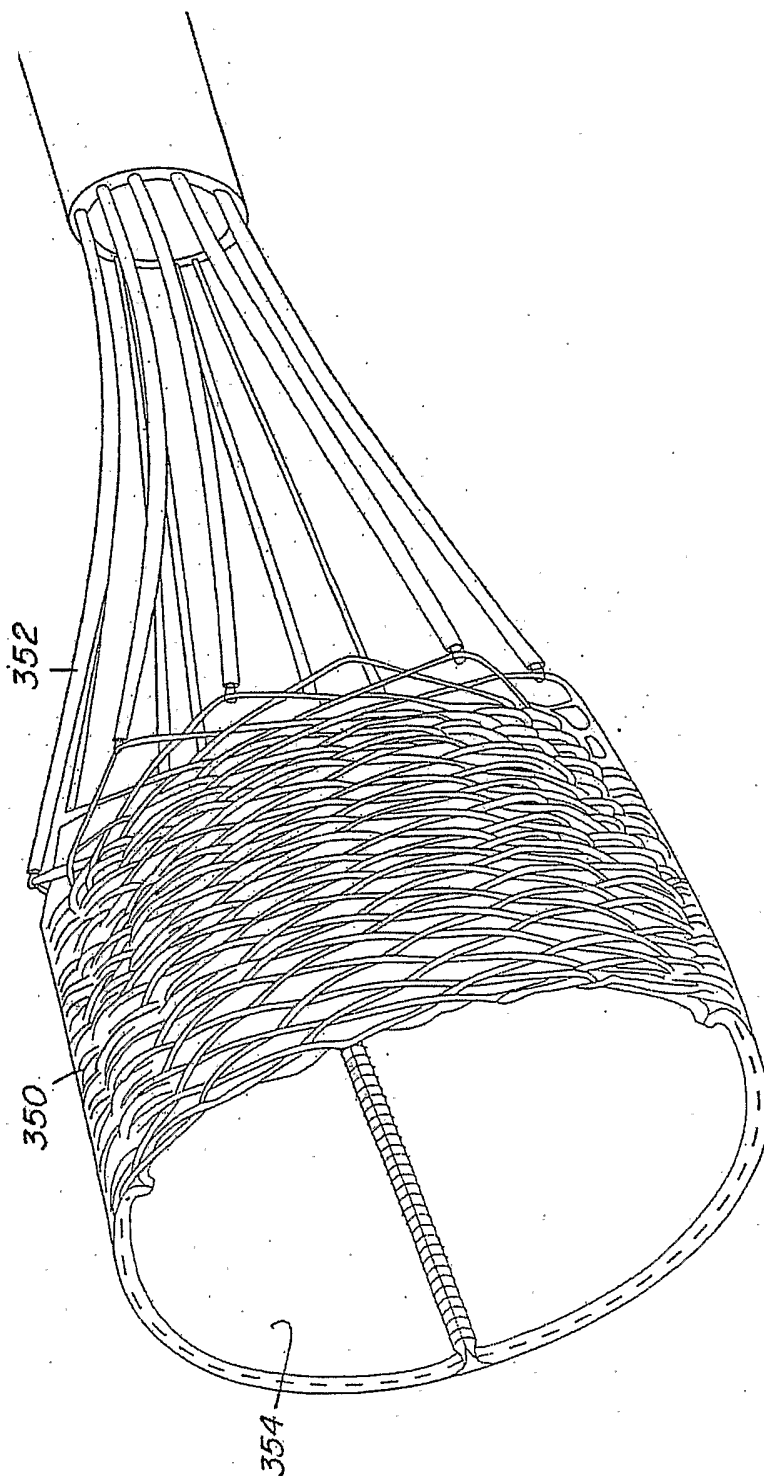

FIG. 24

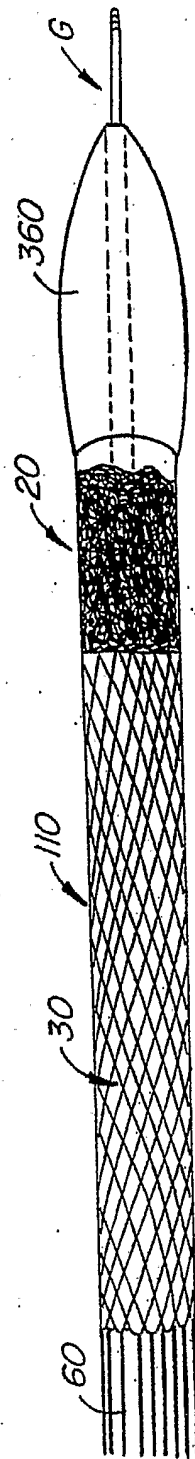

FIG. 25

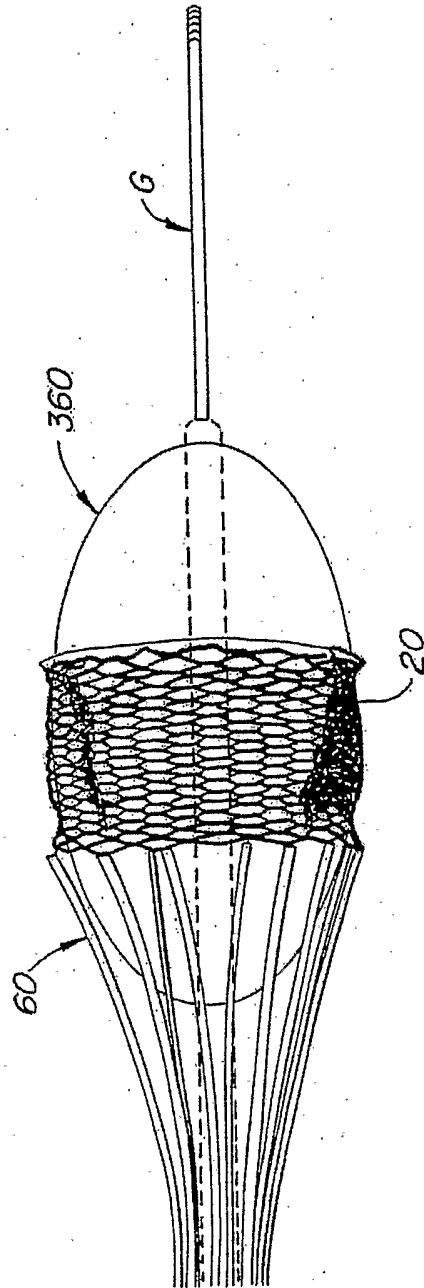

FIG. 26

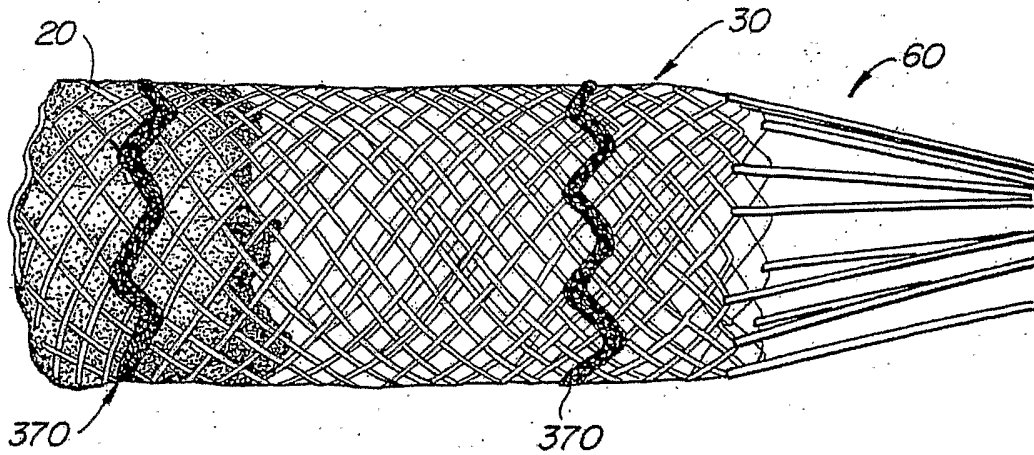

FIG. 27

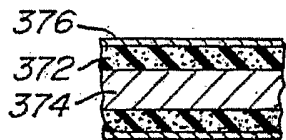

FIG. 28

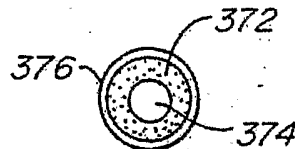

FIG. 29

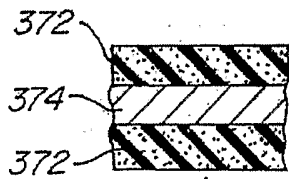

FIG. 30

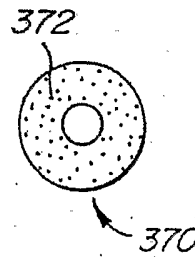

FIG. 31

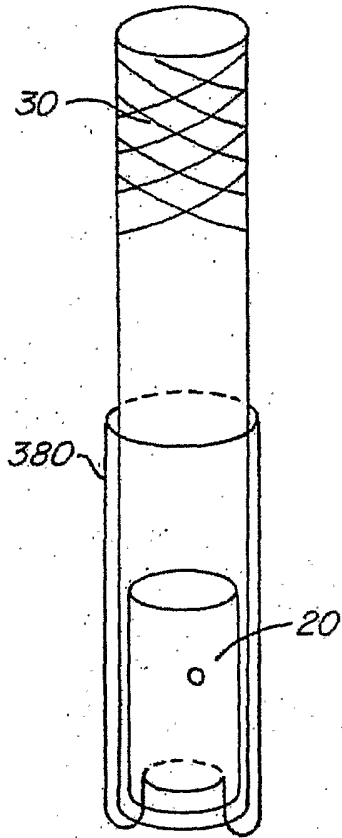

FIG. 32

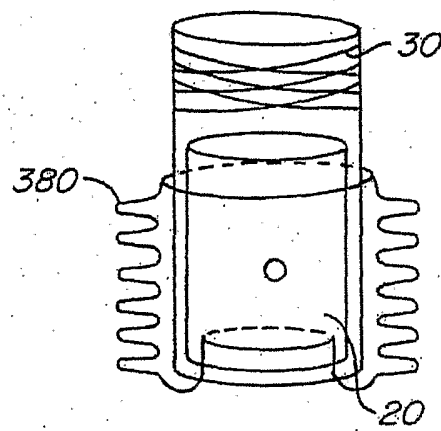

FIG. 33

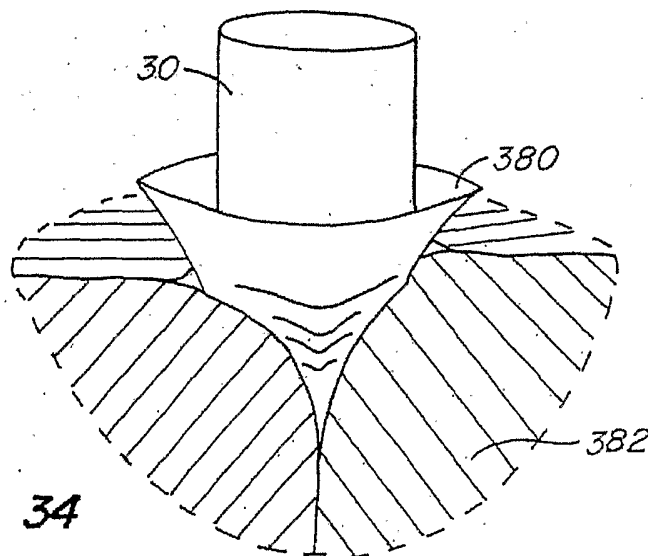

FIG. 34

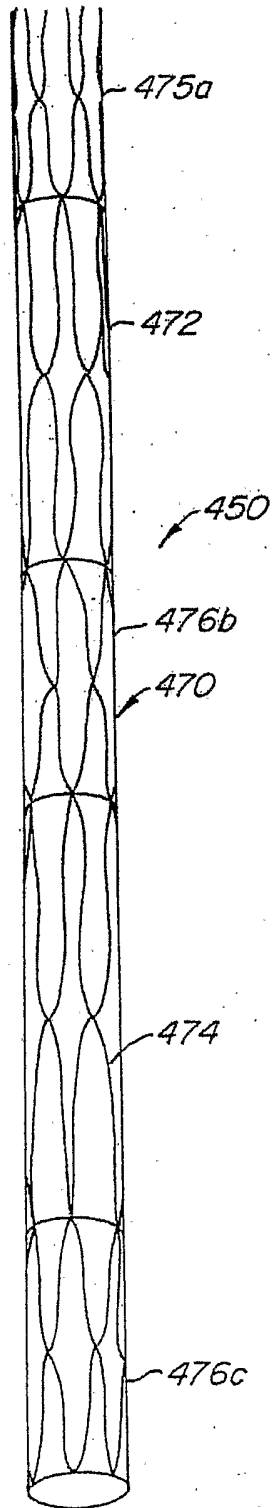

FIG. 35A

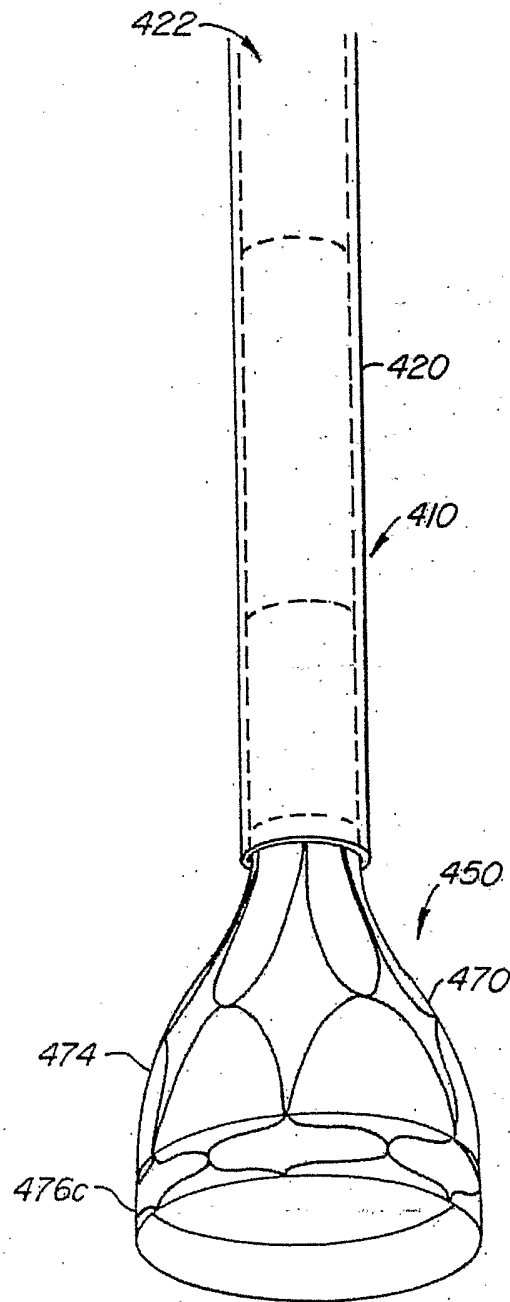

FIG. 35B

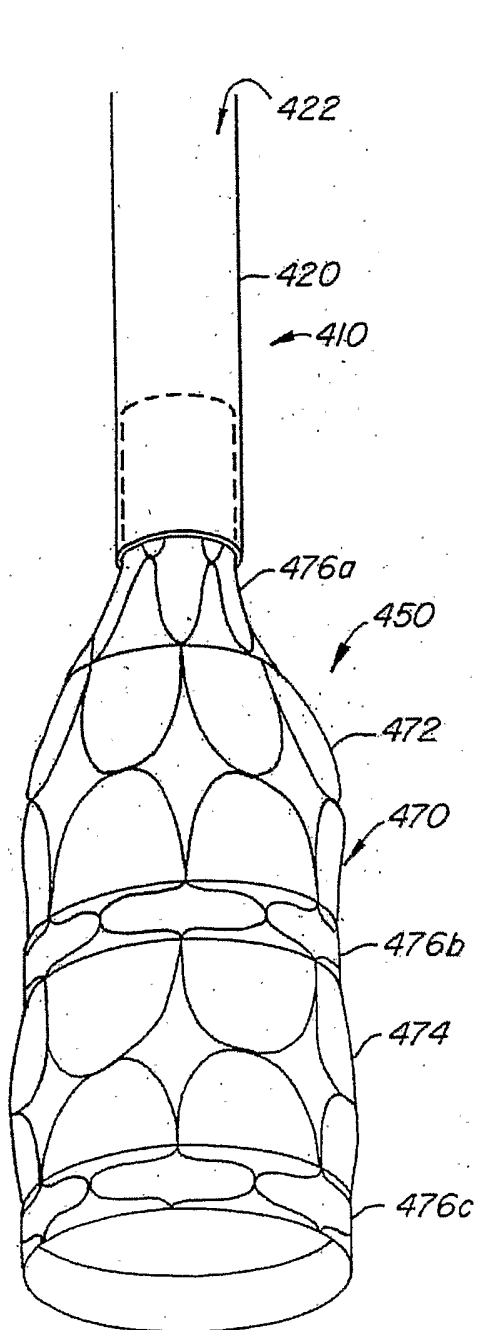

FIG. 35C

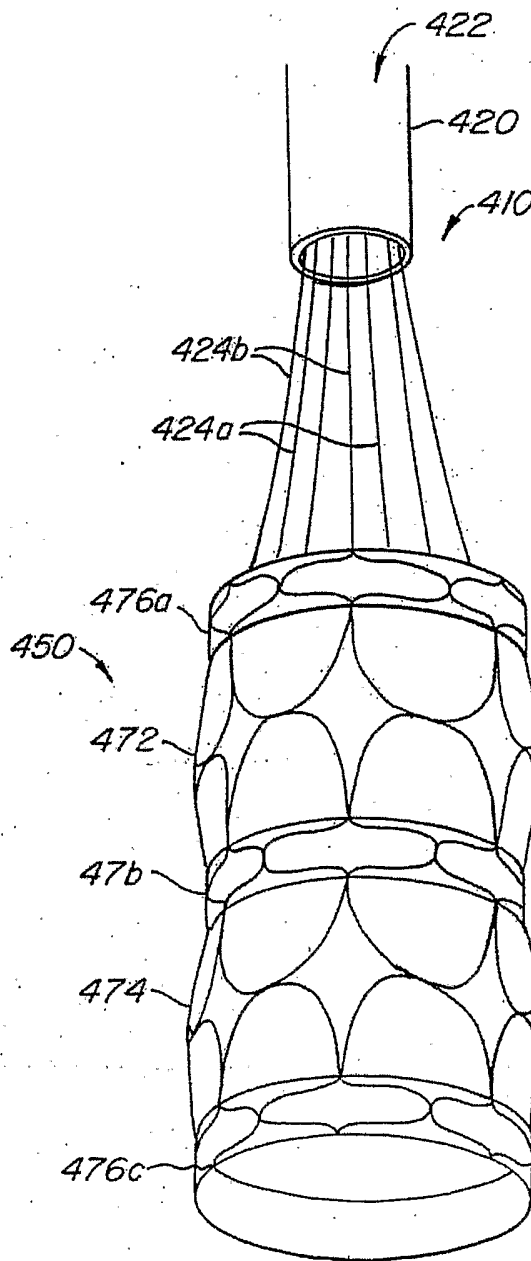

FIG. 35D

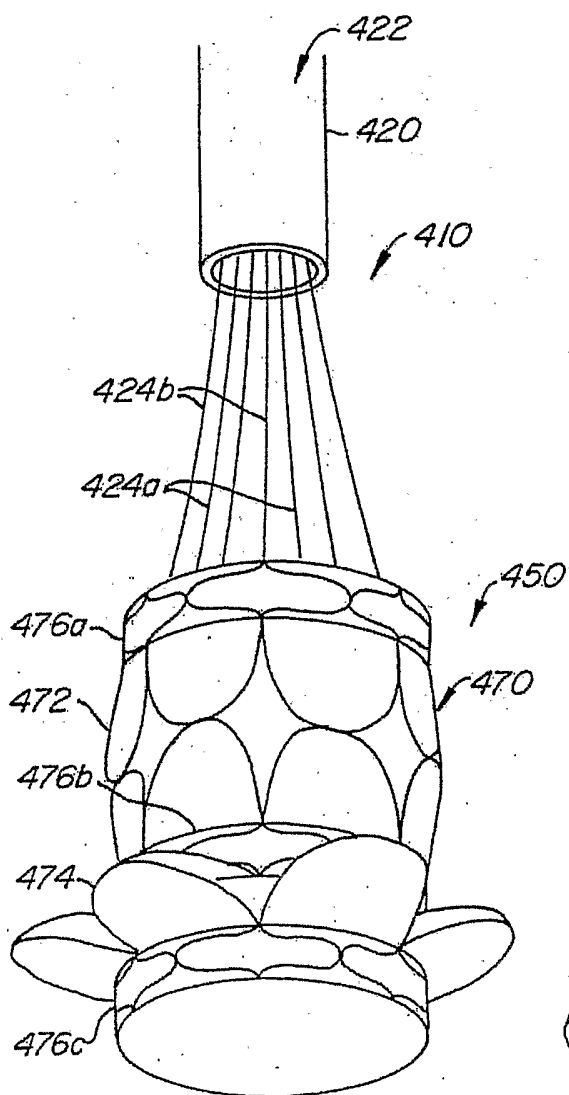

FIG. 35E

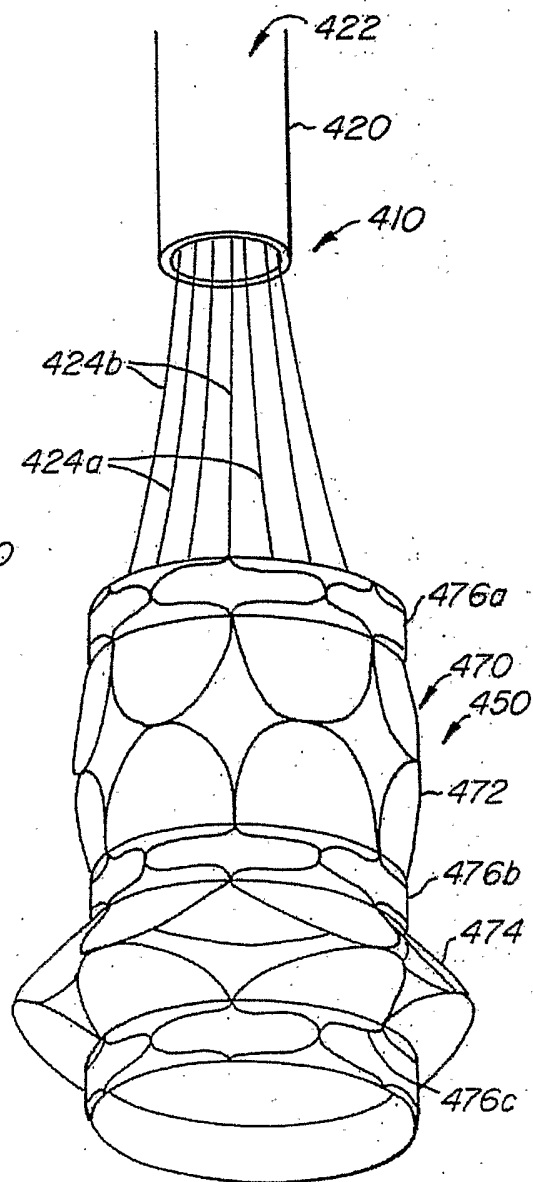

FIG. 35F

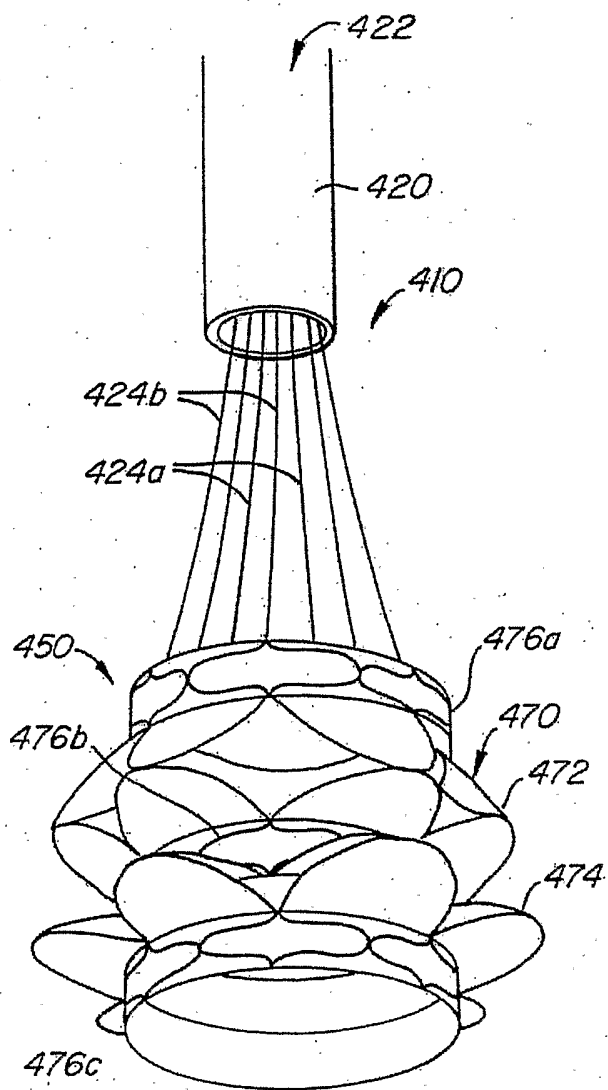

FIG. 35G

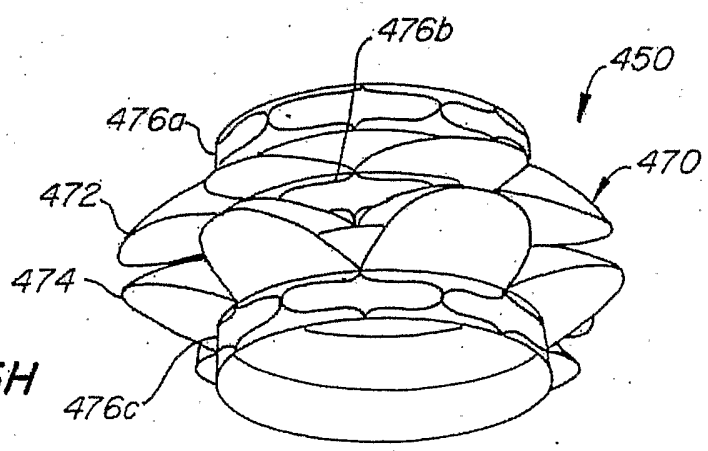

FIG. 35H

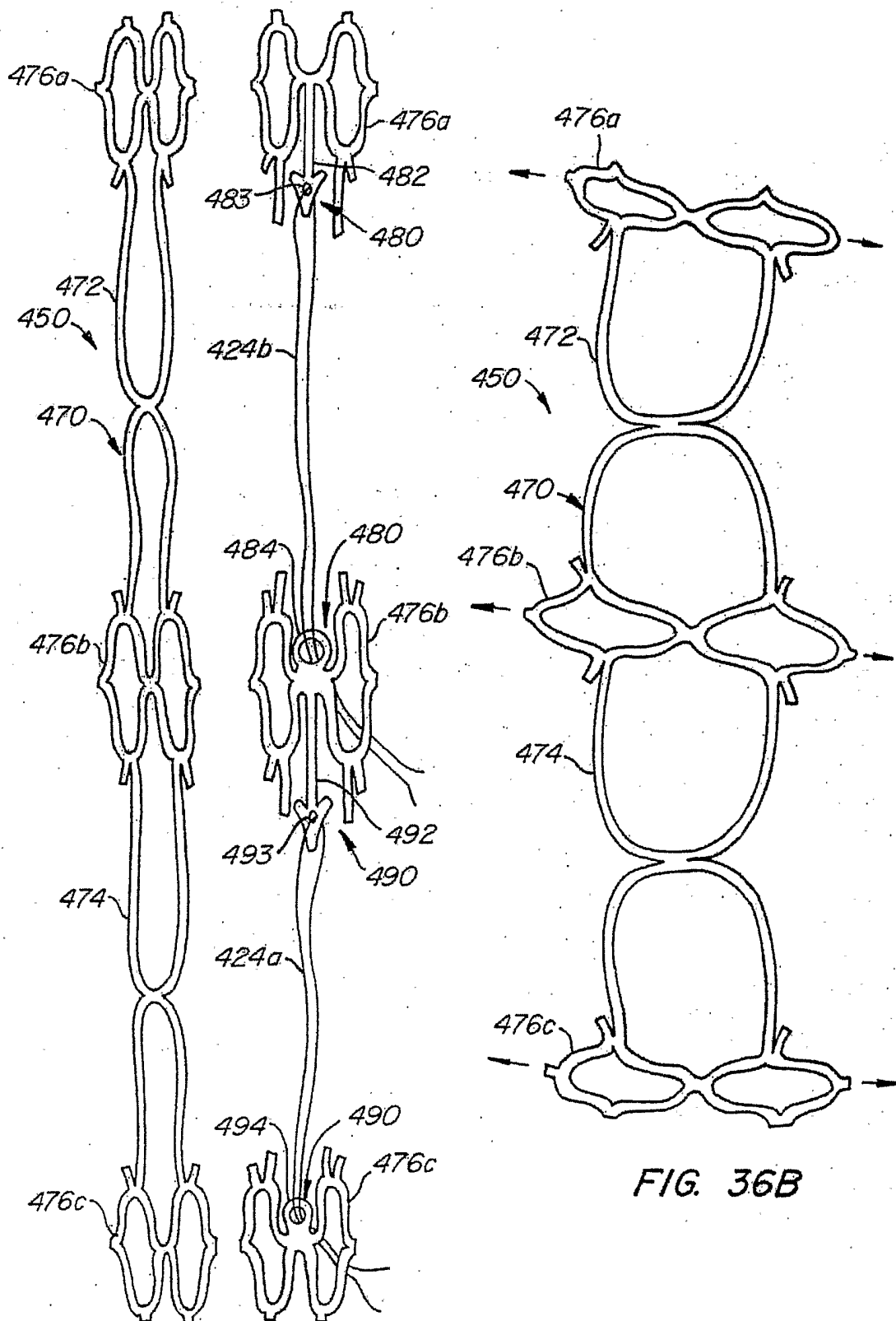

FIG. 36A

FIG. 36B

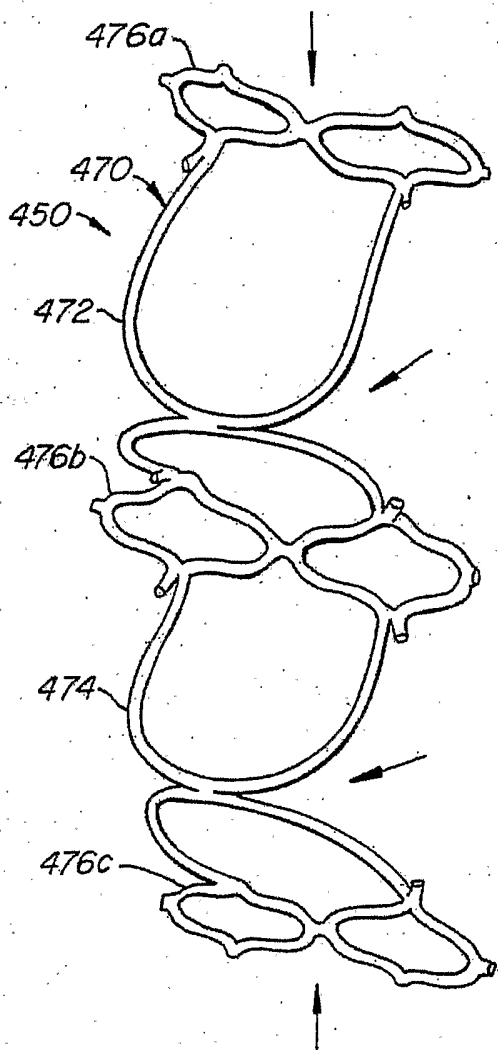

FIG. 36C

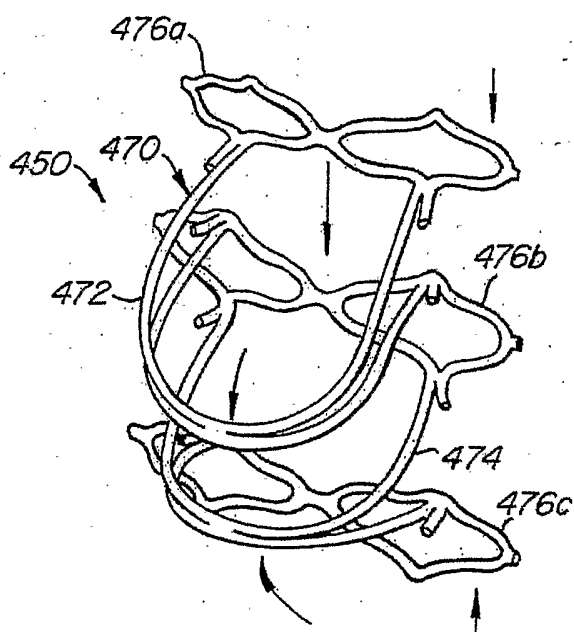

FIG. 36D

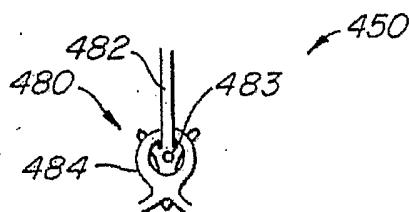

FIG. 36E

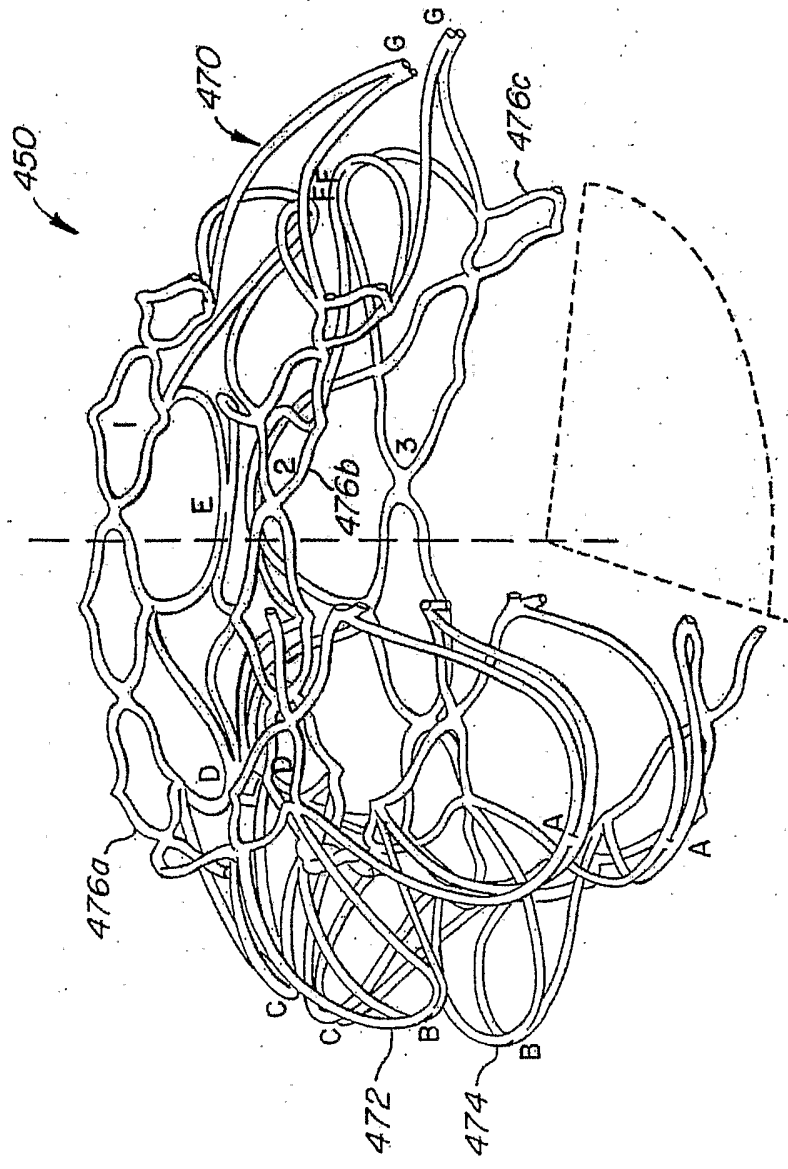

FIG. 37A

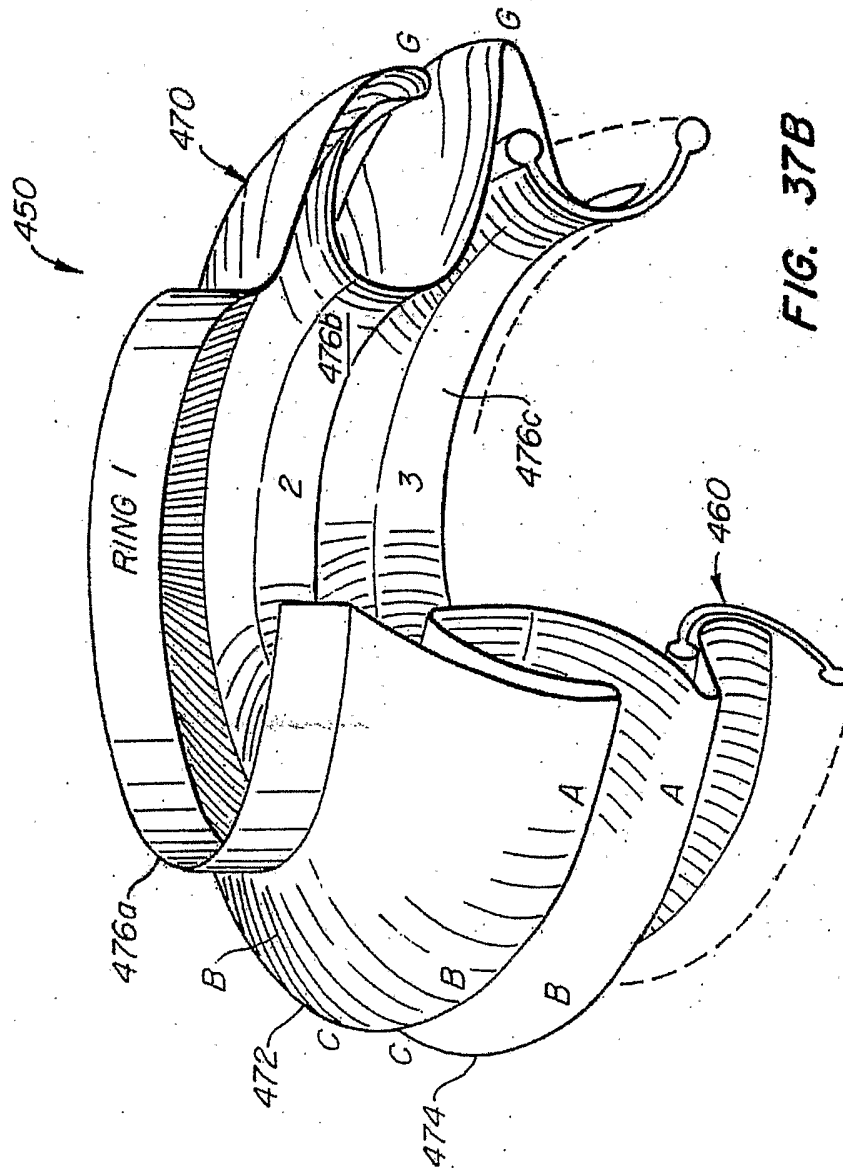

FIG. 37B

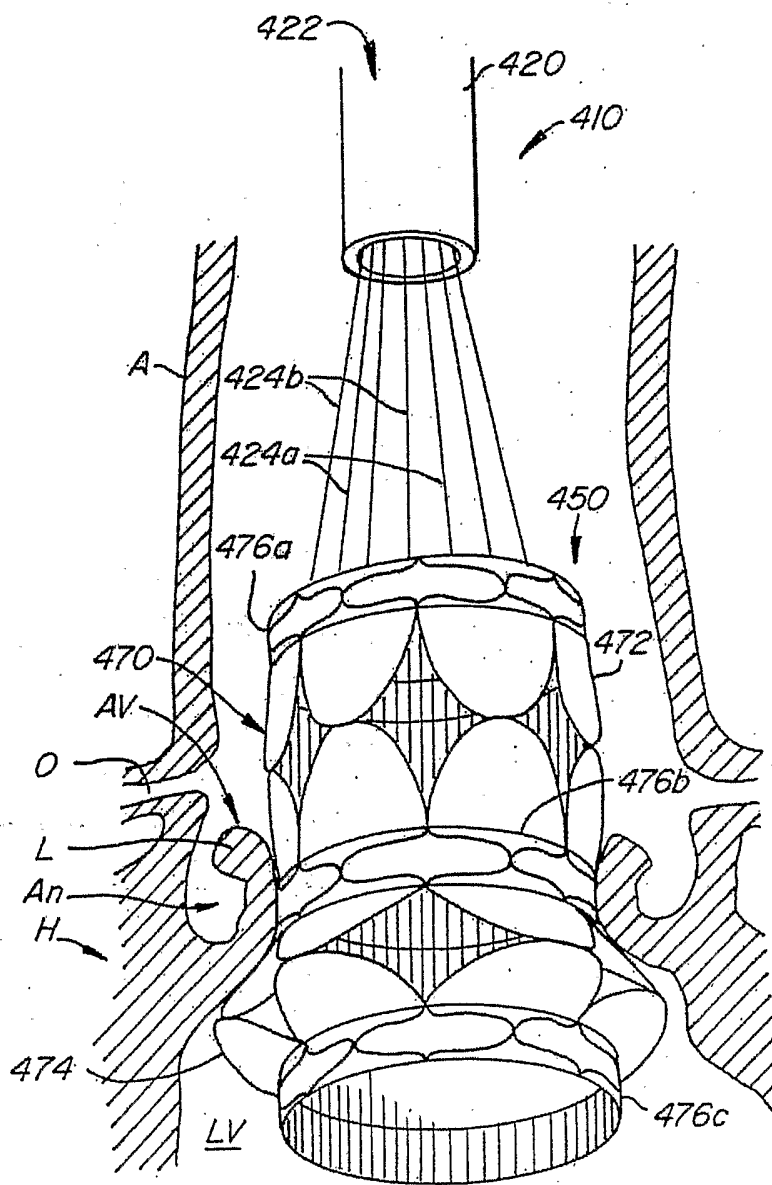

FIG. 38A

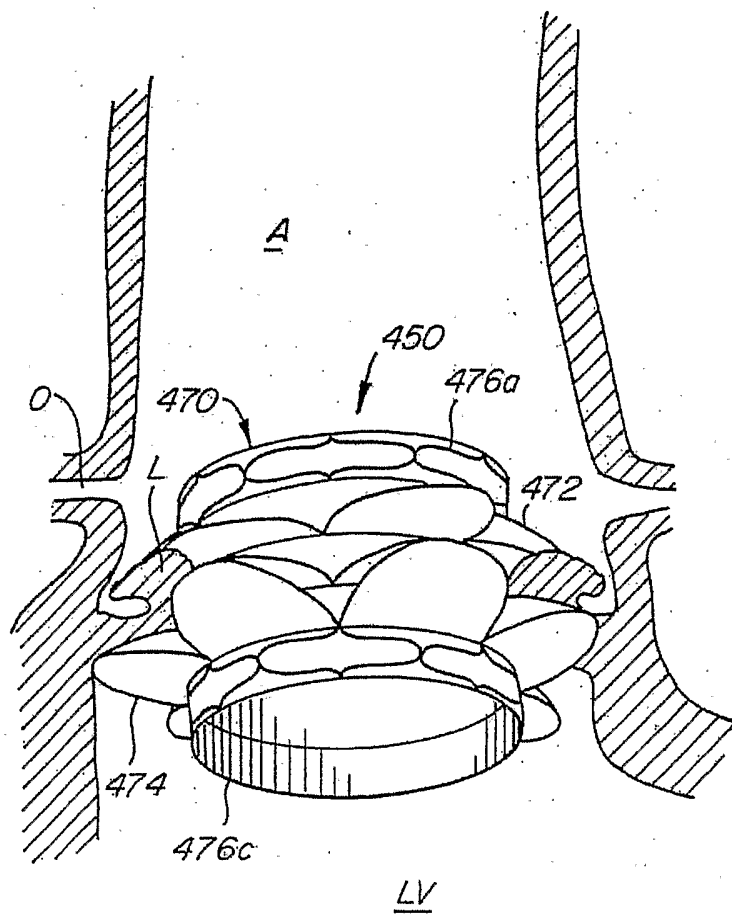

FIG. 38B

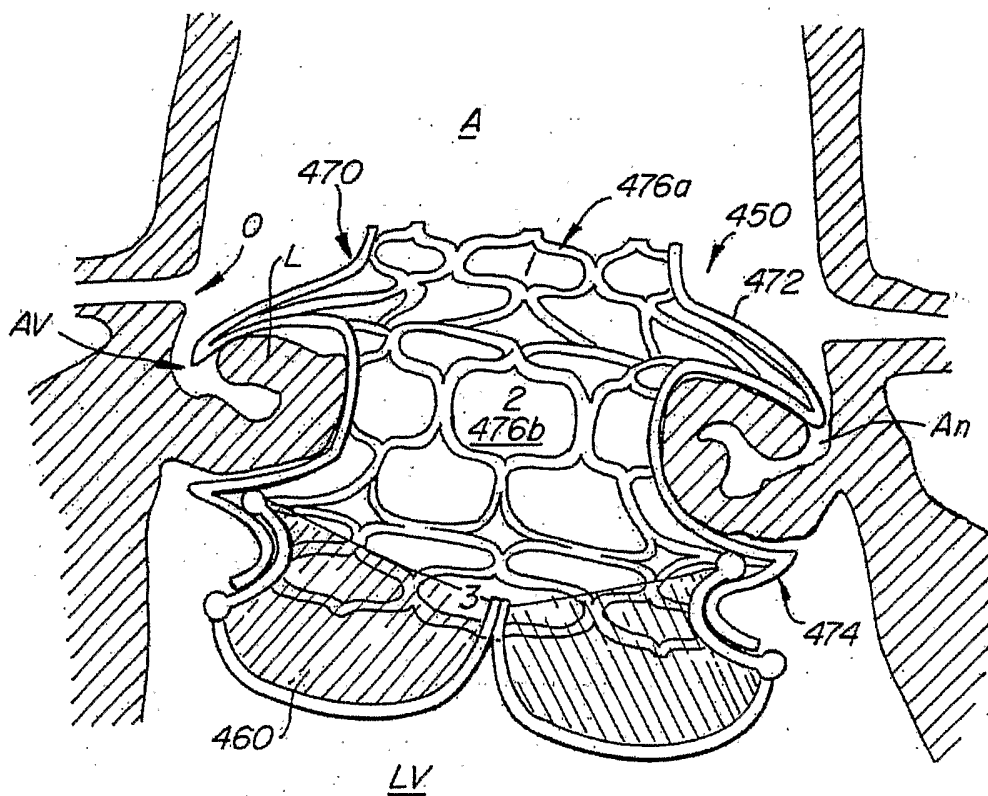
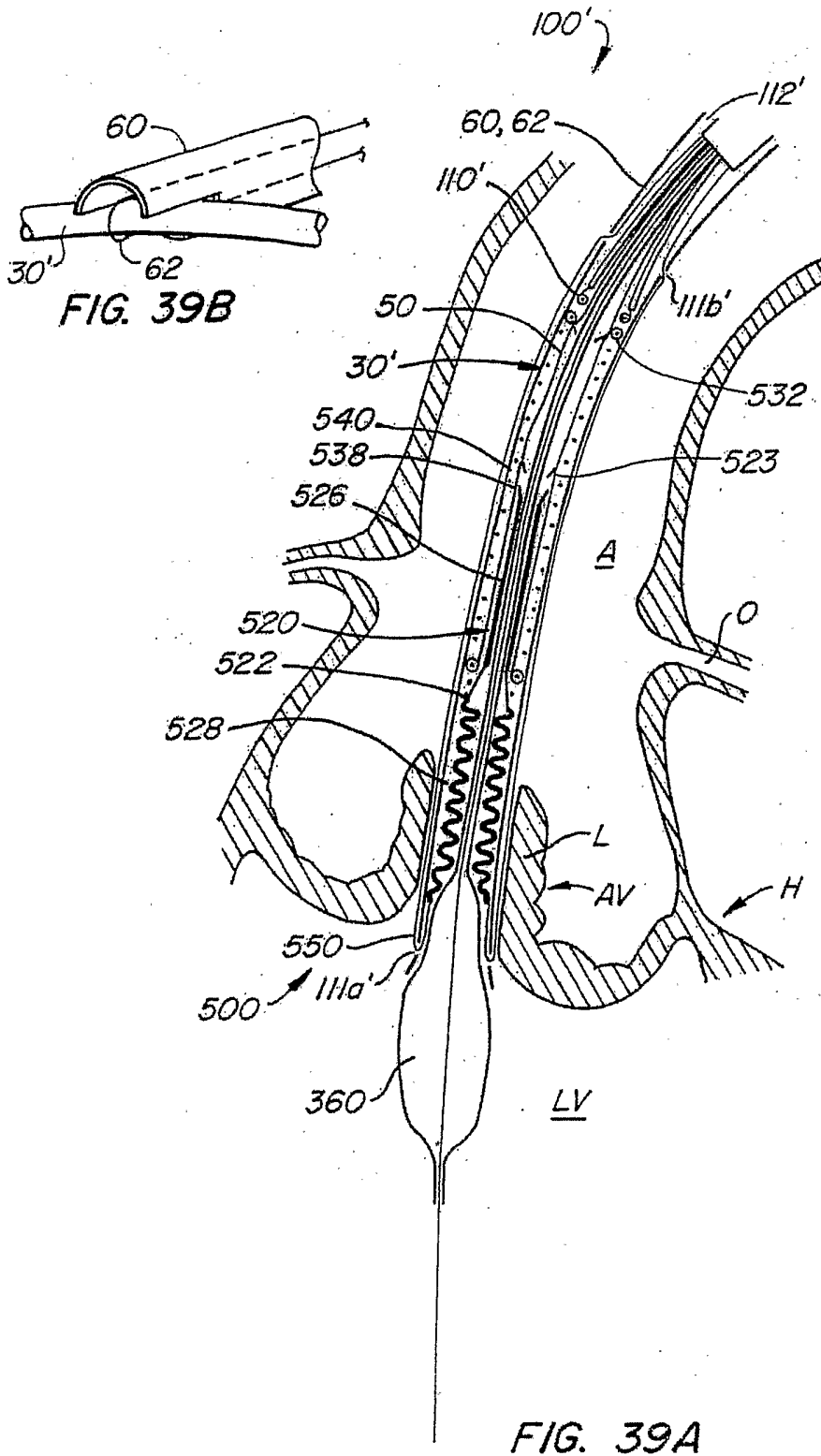

FIG. 38C



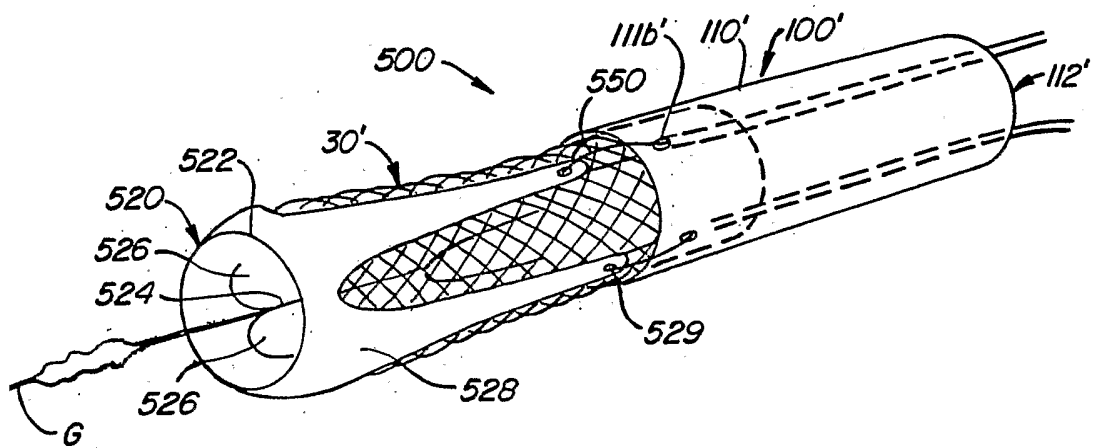

FIG. 39C

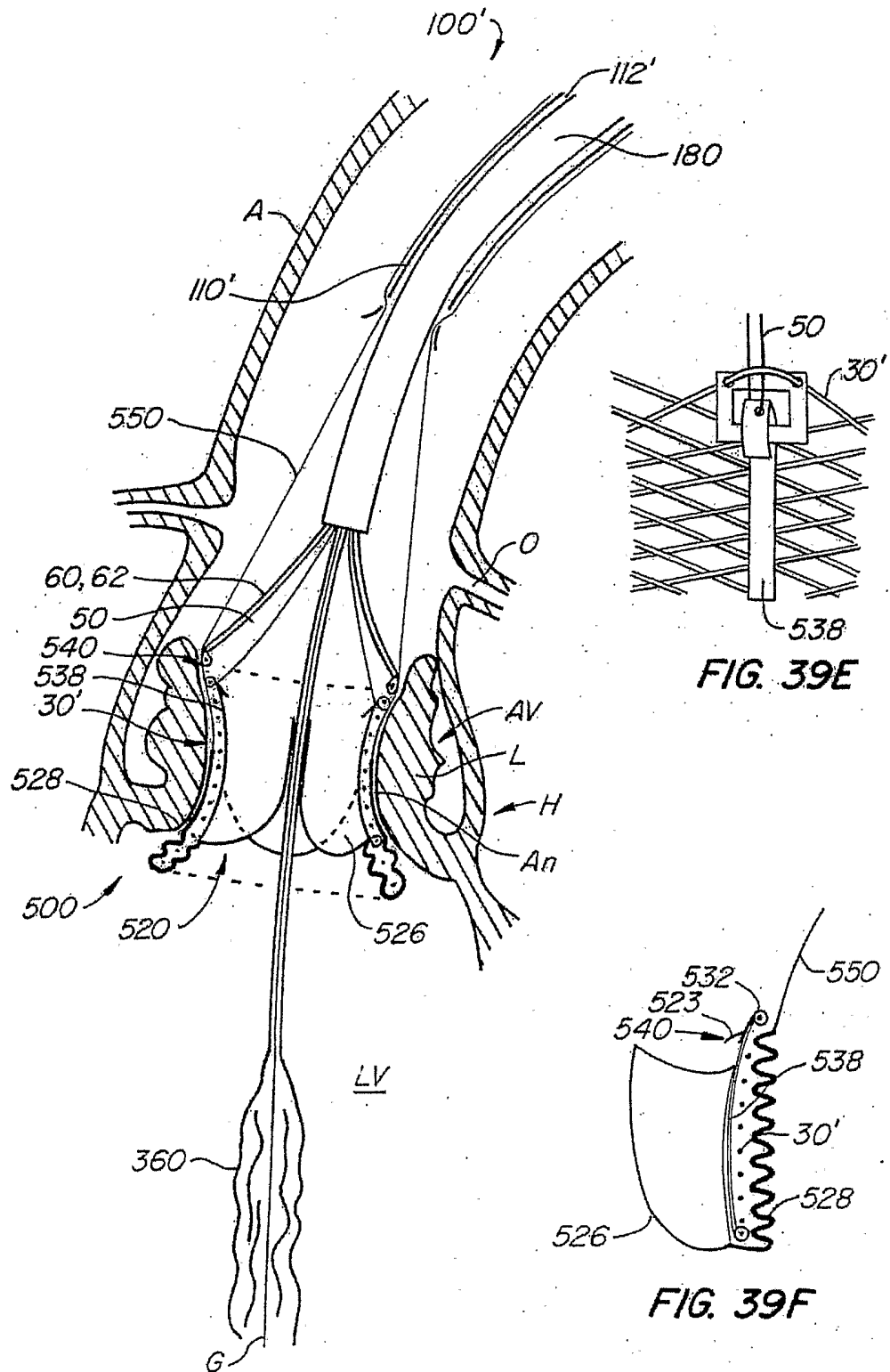

FIG. 39D

FIG. 39E

FIG. 39F

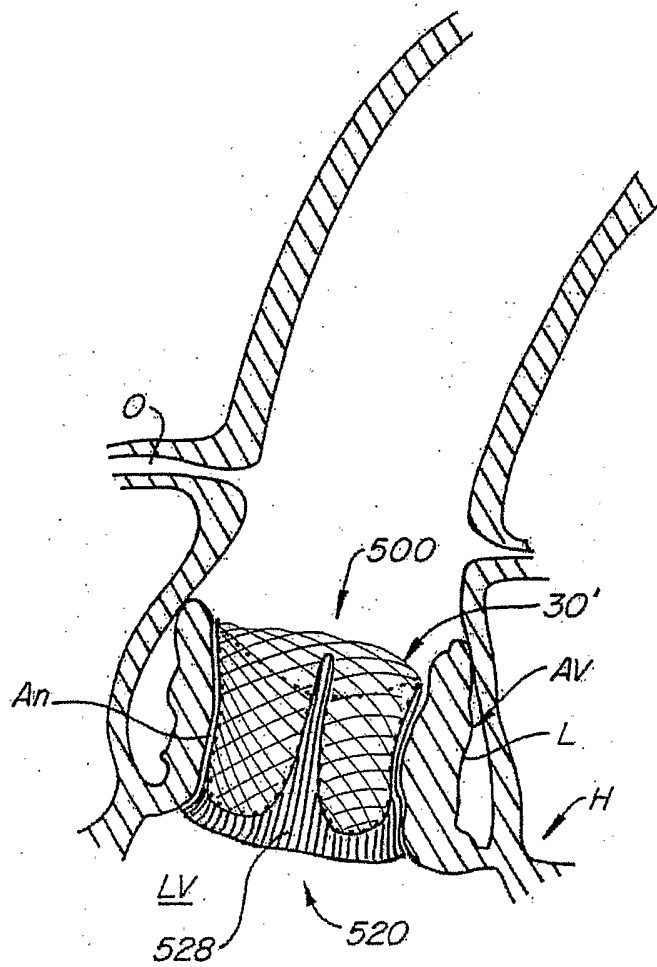

FIG. 39G

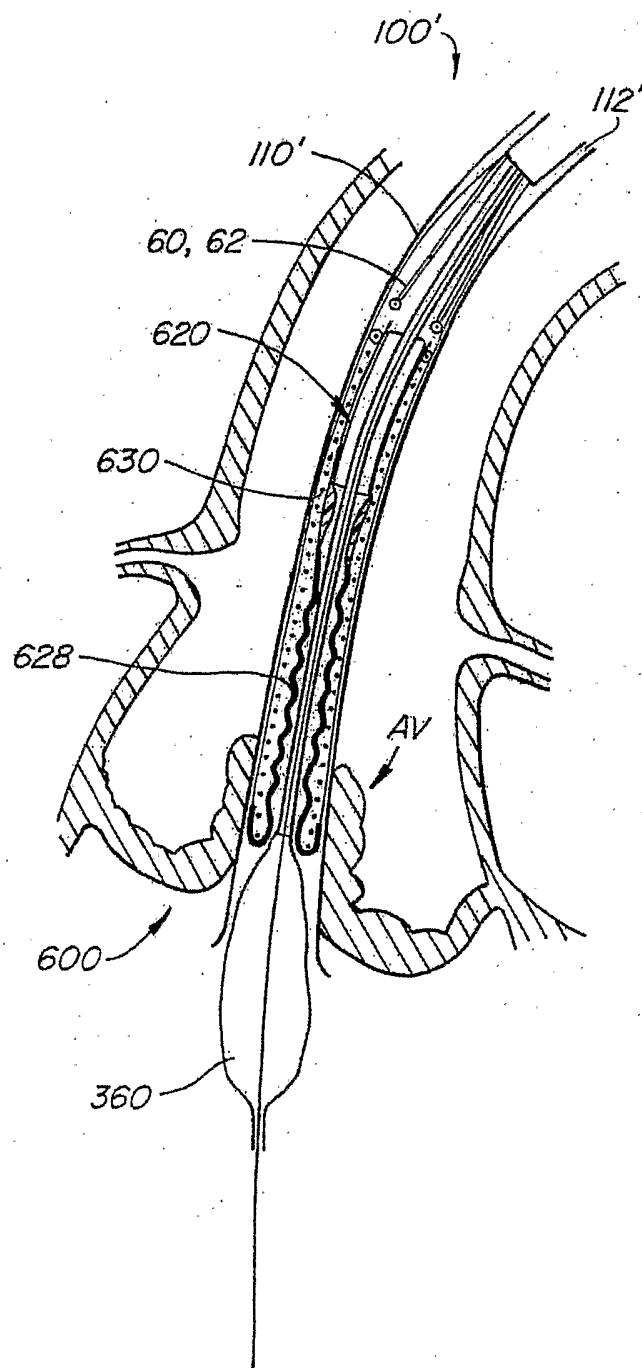

FIG. 40A

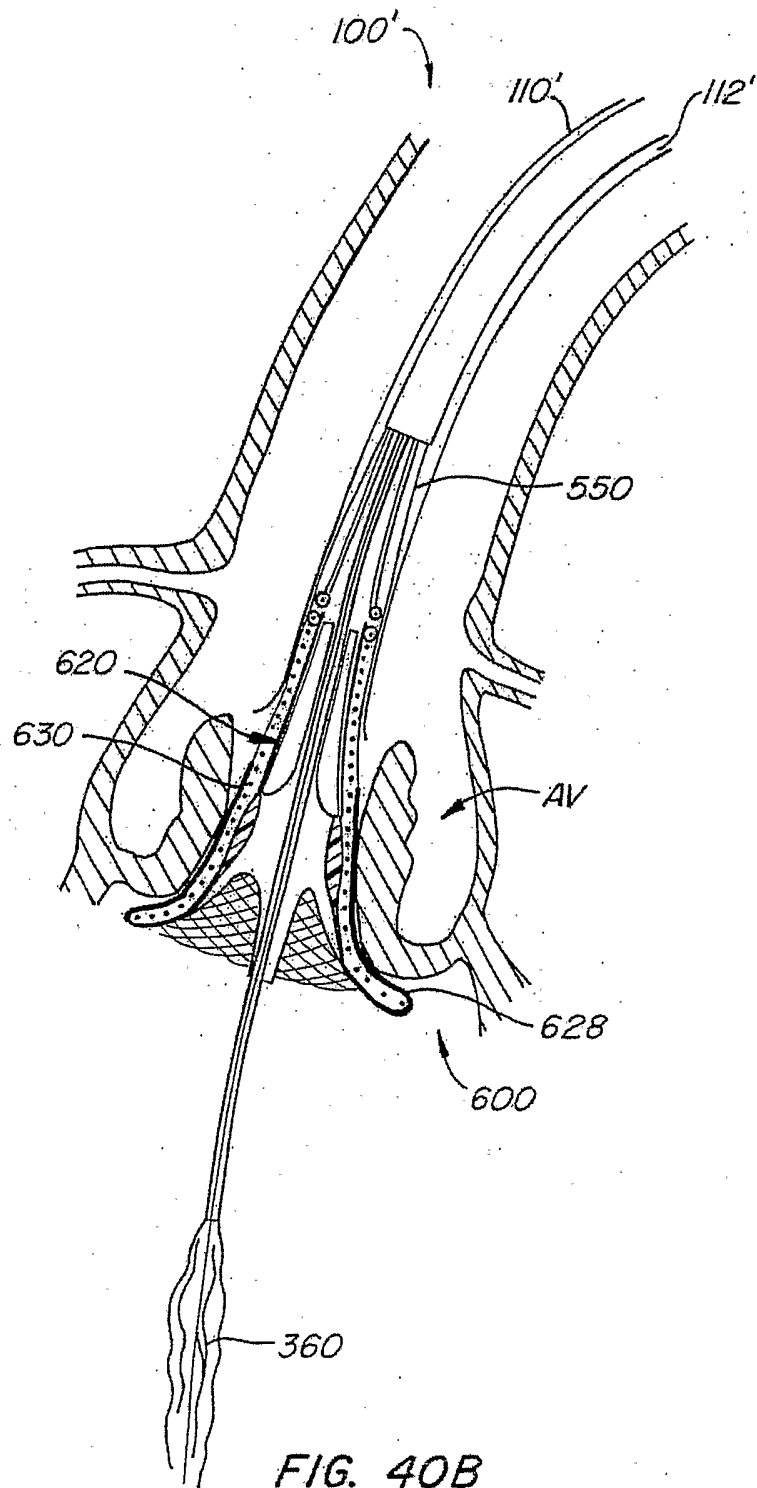

FIG. 40B

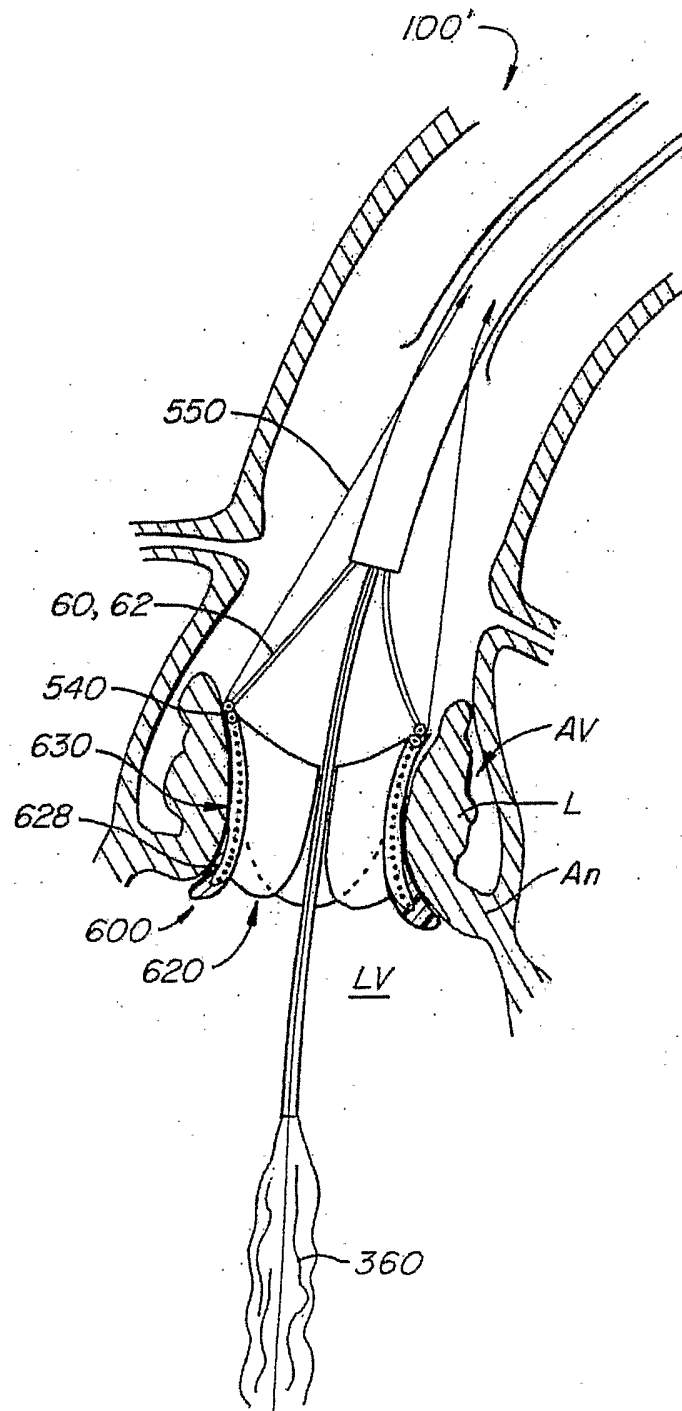

FIG. 40C

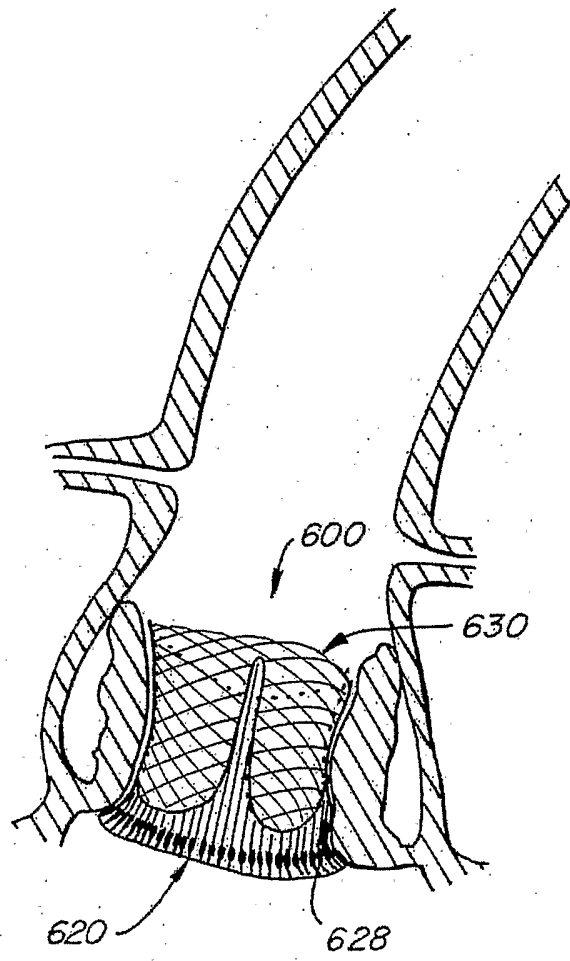

FIG. 40D

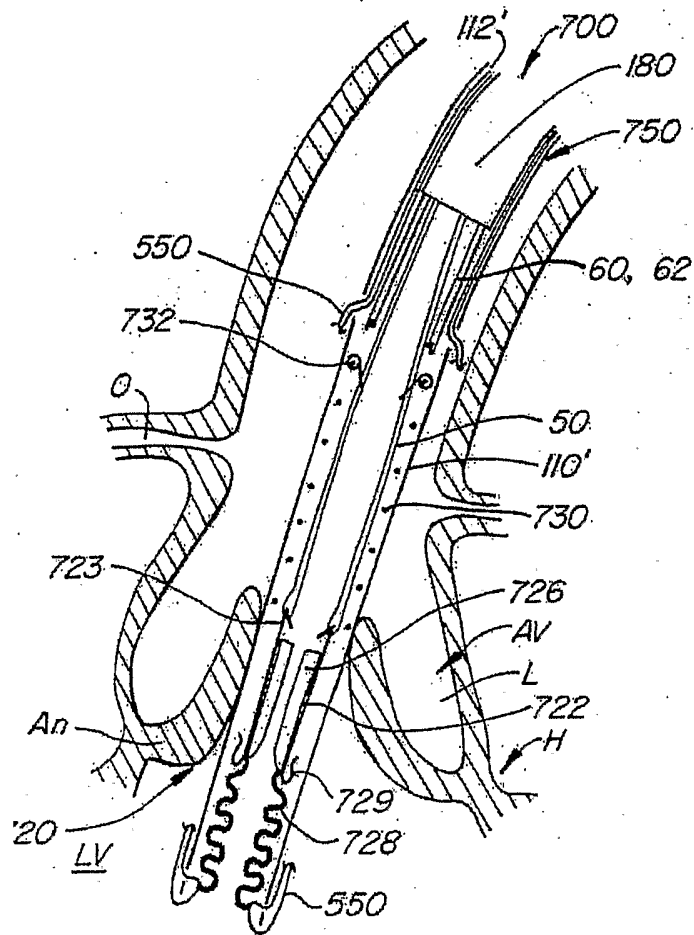

FIG. 41A

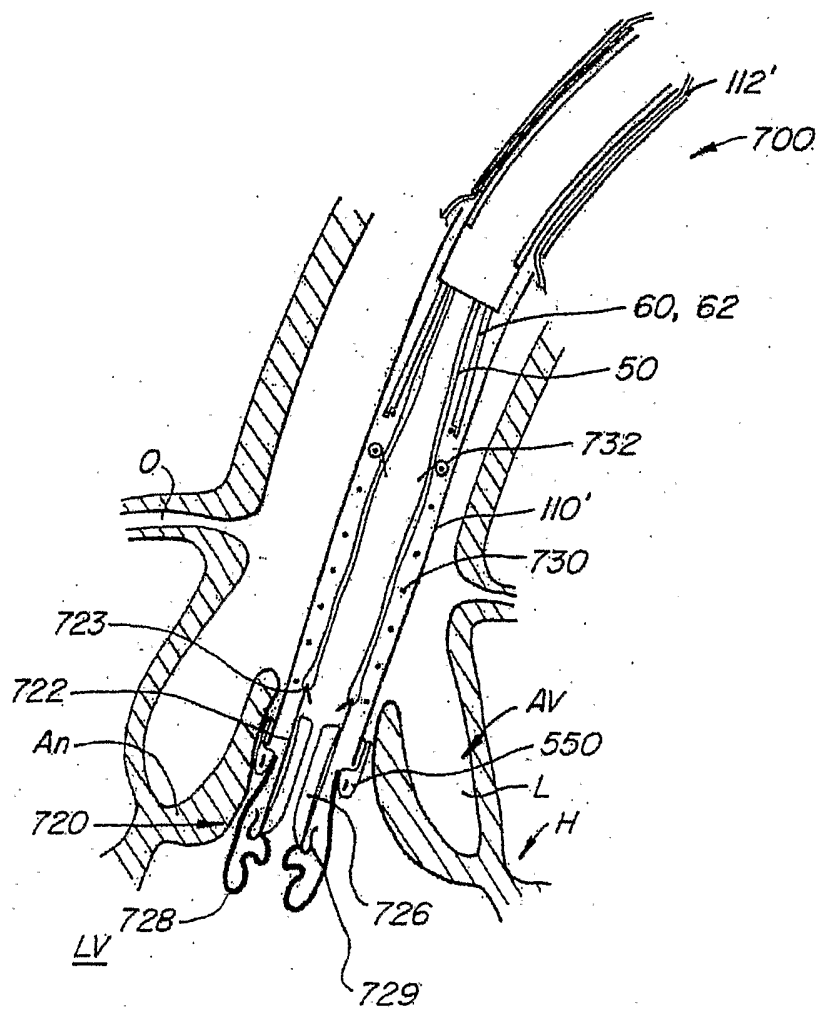

FIG. 4IB

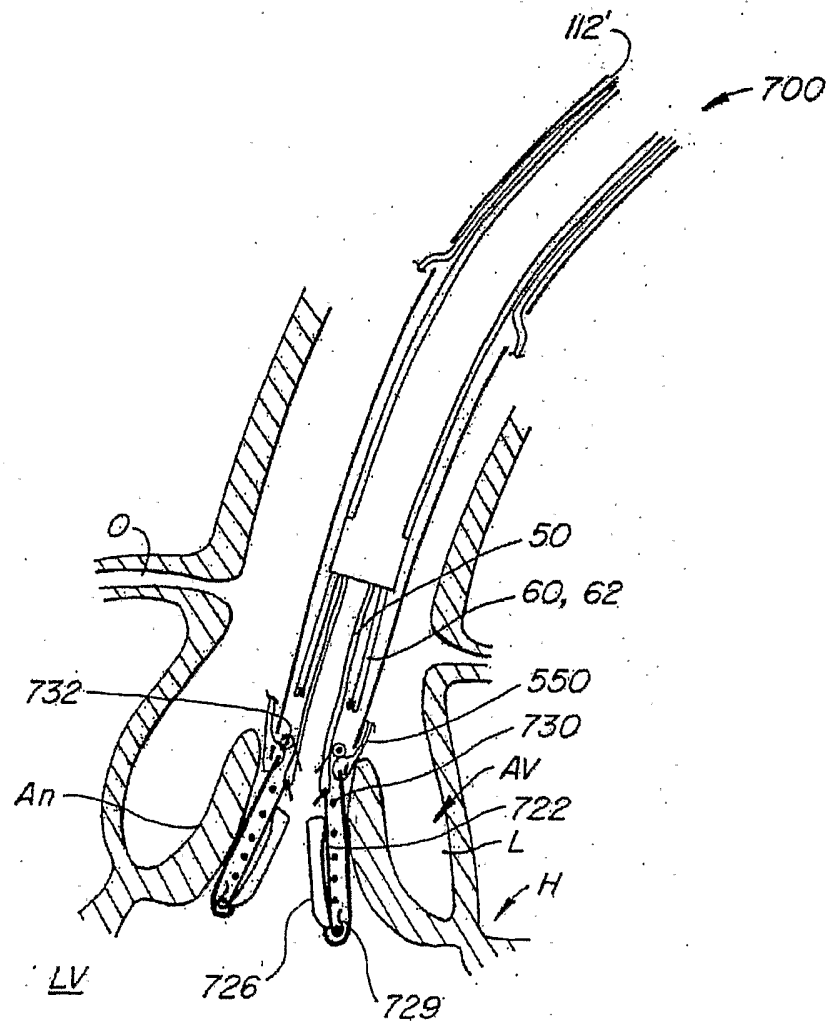

FIG. 41C

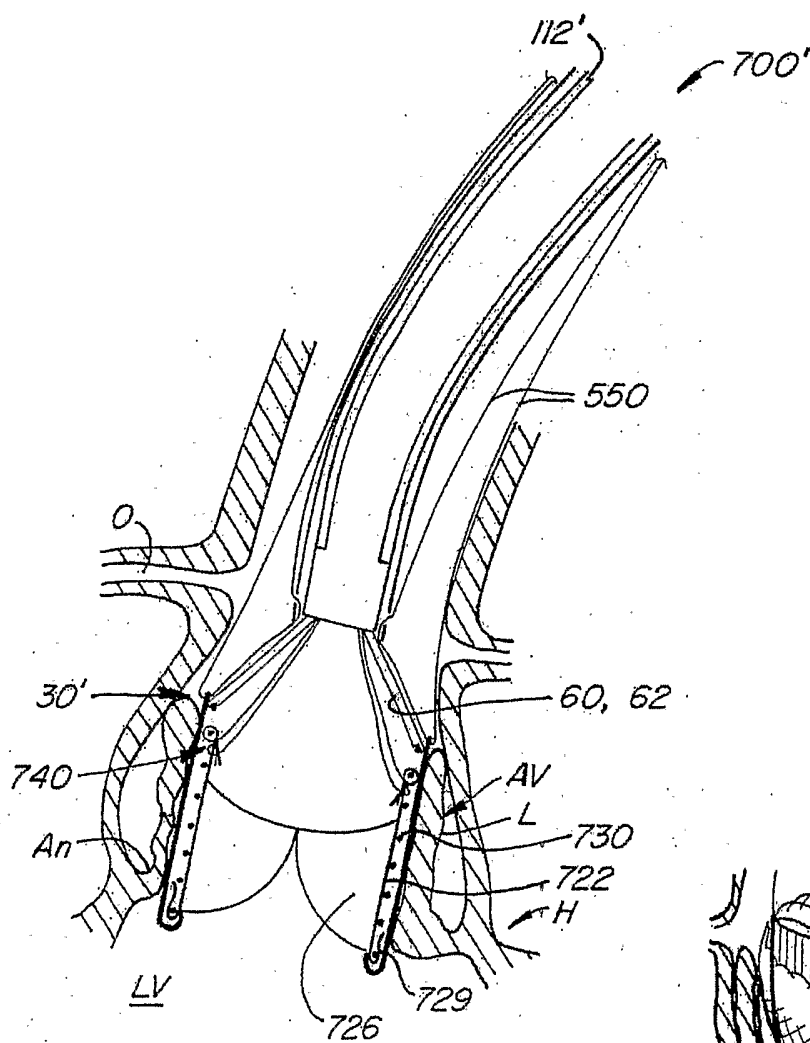

FIG. 41D

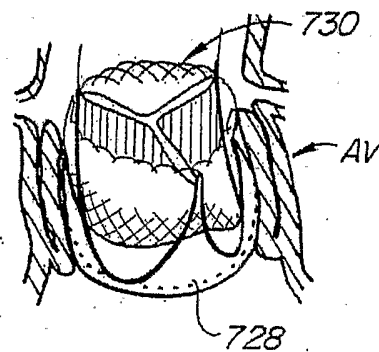

FIG. 41E

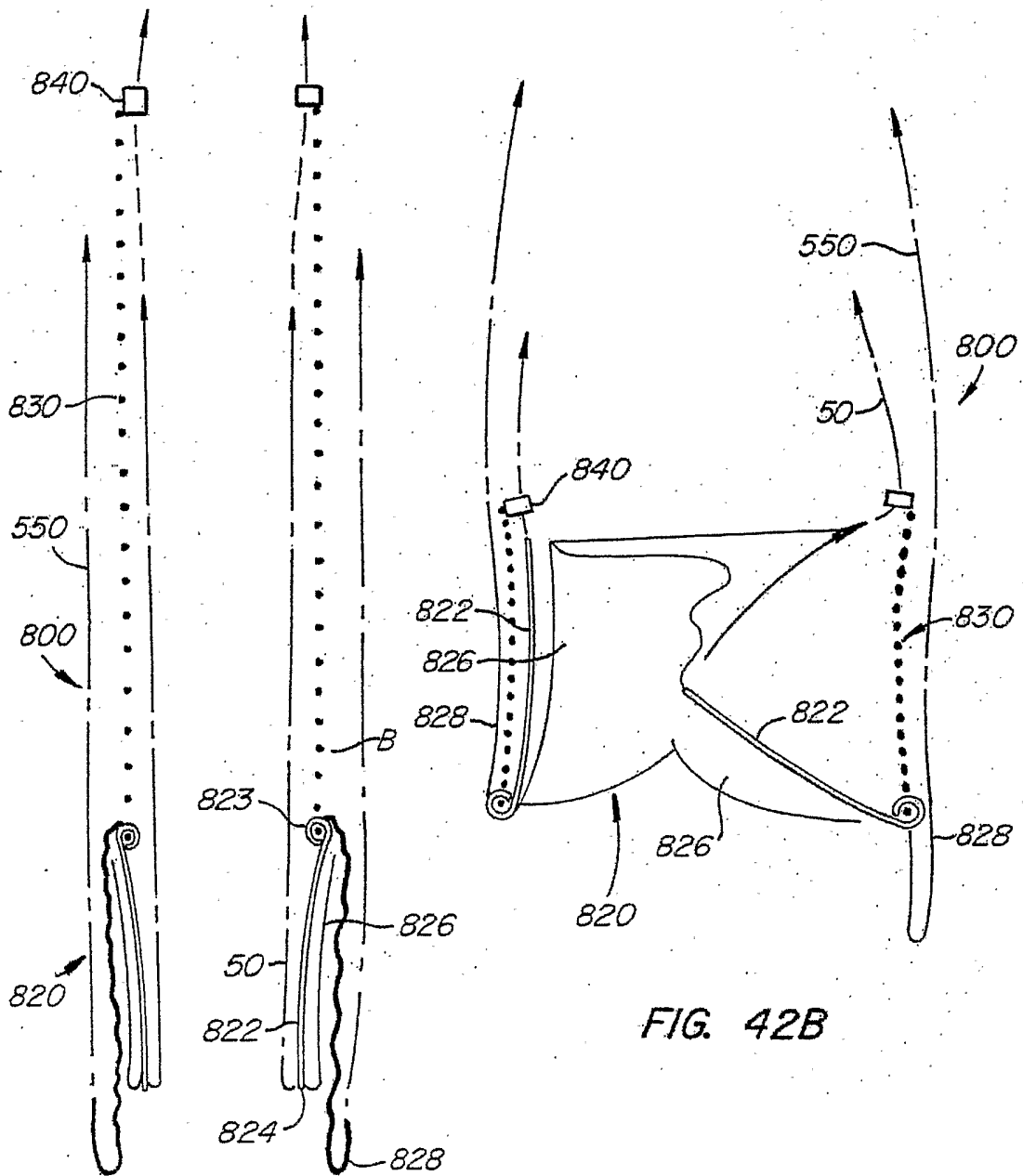

FIG. 42A

FIG. 42B

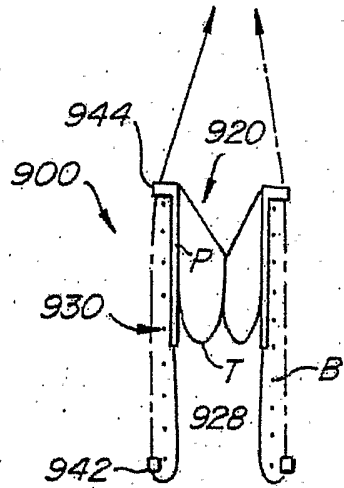

FIG. 43A

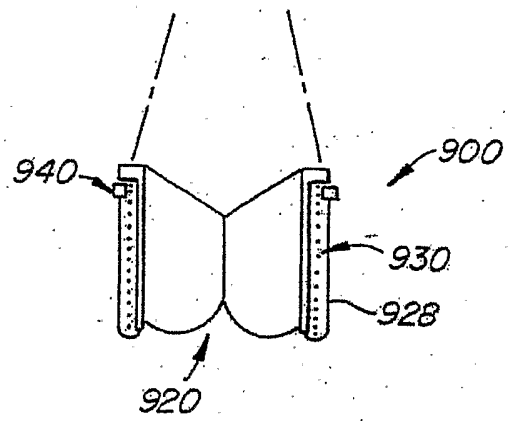

FIG. 43B

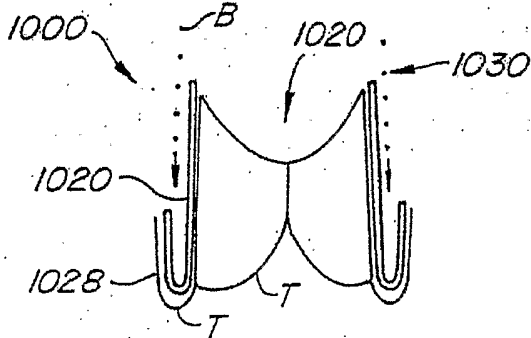

FIG. 44A

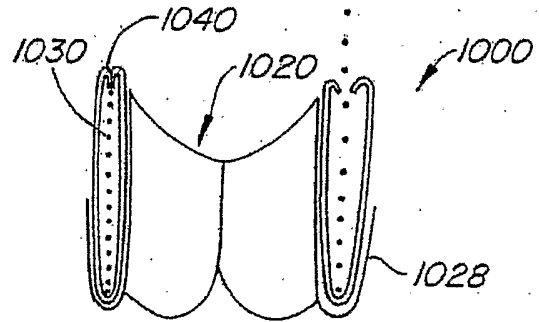

FIG. 44B

INTERNATIONAL SEARCH REPORT

International application No.

PCT/US05/20947

A. CLASSIFICATION OF SUBJECT MATTER

IPC(7) : A61F 02/24
 US CL : 623/2.1

According to International Patent Classification (IPC) or to both national classification and IPC

B. FIELDS SEARCHED

Minimum documentation searched (classification system followed by classification symbols)
 U.S. : 623/2.1, 2.11-2.19, 1.24, 1.26

Documentation searched other than minimum documentation to the extent that such documents are included in the fields searched

Electronic data base consulted during the international search (name of data base and, where practicable, search terms used)
 Please See Continuation Sheet

C. DOCUMENTS CONSIDERED TO BE RELEVANT

Category *	Citation of document, with indication, where appropriate, of the relevant passages	Relevant to claim No.
X	US 6,425,916 B1 (GARRISON et al) 30 July 2002 (30.07.2002), see figures 32-38 and respective portions of the specification.	1, 4-12, 14-17, 19-21, 25, 27, -30, 32-36, 38, and 39
X	US 2004/0049262 A1 (OBERMILLER et al) 11 March 2004 (11.03.2004), see fig.5, 16 and respective portions of the specification.	1-4, 6-10, 12, 14, 15, and 21-23
X	US 6,676,698 B2 (MCGUCKIN, JR. et al) 13 January 2004 (13.01.2004), see fig.35-55 and respective portions of the specification.	1, 4-12, 14-16, 21, 25, 27, 28, 30, 32, 33, 35, 38, and 39
A	US 5,855,601 A (BESSLER et al) 05 January 1999 (05.01.1999), see entire specification.	1-40

Further documents are listed in the continuation of Box C.

See patent family annex.

* Special categories of cited documents:

"A" document defining the general state of the art which is not considered to be of particular relevance

"E" earlier application or patent published on or after the international filing date

"L" document which may throw doubts on priority claim(s) or which is cited to establish the publication date of another citation or other special reason (as specified)

"O" document referring to an oral disclosure, use, exhibition or other means

"P" document published prior to the international filing date but later than the priority date claimed

"T"

later document published after the international filing date or priority date and not in conflict with the application but cited to understand the principle or theory underlying the invention

"X"

document of particular relevance; the claimed invention cannot be considered novel or cannot be considered to involve an inventive step when the document is taken alone

"Y"

document of particular relevance; the claimed invention cannot be considered to involve an inventive step when the document is combined with one or more other such documents, such combination being obvious to a person skilled in the art

"&"

document member of the same patent family

Date of the actual completion of the international search

30 August 2005 (30.08.2005)

Date of mailing of the international search report

06 OCT 2005

Name and mailing address of the ISA/US

Mail Stop PCT, Attn: ISA/US
 Commissioner for Patents
 P.O. Box 1450
 Alexandria, Virginia 22313-1450

Facsimile No. (703) 305-3230

Authorized officer

Cheryl Miller

Telephone No. (571) 272-4755

Sheyla H. Veney
 Sheyla H. Veney
 Paralegal Specialist
 Tech. Center 3700

INTERNATIONAL SEARCH REPORT

International application No.

PCT/US05/20947

Continuation of B. FIELDS SEARCHED Item 3:

East database

search terms: everted, inverted, valve, leaflet, heart