



- (51) International Patent Classification:  
*A61N 1/36* (2006.01)    *A61N 1/05* (2006.01)
- (21) International Application Number:  
PCT/US2014/051235
- (22) International Filing Date:  
15 August 2014 (15.08.2014)
- (25) Filing Language: English
- (26) Publication Language: English
- (30) Priority Data:  
61/894,795    23 October 2013 (23.10.2013)    US  
14/460,139    14 August 2014 (14.08.2014)    US
- (71) Applicant: SYNTILLA MEDICAL LLC [US/US]; 4516 Lovers Lane, Suite 300, Dallas, TX 75225 (US).
- (72) Inventors: REED, Kenneth, Lyle; 11970 N. Central Expressway, Suite 510, Dallas, TX 75243 (US). BULGER, Robert, Raymond; 8501 Swananoah Road, Dallas, TX 75209 (US).
- (74) Agent: HOWISON, Gregory, M.; Howison & Arnott, L.L.P., P.O. Box 741715, Dallas, TX 75374-1715 (US).
- (81) Designated States (unless otherwise indicated, for every kind of national protection available): AE, AG, AL, AM, AO, AT, AU, AZ, BA, BB, BG, BH, BN, BR, BW, BY,

BZ, CA, CH, CL, CN, CO, CR, CU, CZ, DE, DK, DM, DO, DZ, EC, EE, EG, ES, FI, GB, GD, GE, GH, GM, GT, HN, HR, HU, ID, IL, IN, IR, IS, JP, KE, KG, KN, KP, KR, KZ, LA, LC, LK, LR, LS, LT, LU, LY, MA, MD, ME, MG, MK, MN, MW, MX, MY, MZ, NA, NG, NI, NO, NZ, OM, PA, PE, PG, PH, PL, PT, QA, RO, RS, RU, RW, SA, SC, SD, SE, SG, SK, SL, SM, ST, SV, SY, TH, TJ, TM, TN, TR, TT, TZ, UA, UG, US, UZ, VC, VN, ZA, ZM, ZW.

- (84) Designated States (unless otherwise indicated, for every kind of regional protection available): ARIPO (BW, GH, GM, KE, LR, LS, MW, MZ, NA, RW, SD, SL, SZ, TZ, UG, ZM, ZW), Eurasian (AM, AZ, BY, KG, KZ, RU, TJ, TM), European (AL, AT, BE, BG, CH, CY, CZ, DE, DK, EE, ES, FI, FR, GB, GR, HR, HU, IE, IS, IT, LT, LU, LV, MC, MK, MT, NL, NO, PL, PT, RO, RS, SE, SI, SK, SM, TR), OAPI (BF, BJ, CF, CG, CI, CM, GA, GN, GQ, GW, KM, ML, MR, NE, SN, TD, TG).

**Declarations under Rule 4.17:**

- as to applicant's entitlement to apply for and be granted a patent (Rule 4.17(ii))

**Published:**

- without international search report and to be republished upon receipt of that report (Rule 48.2(g))

(54) Title: IMPLANTABLE HEAD MOUNTED NEUROSTIMULATION SYSTEM FOR HEAD PAIN

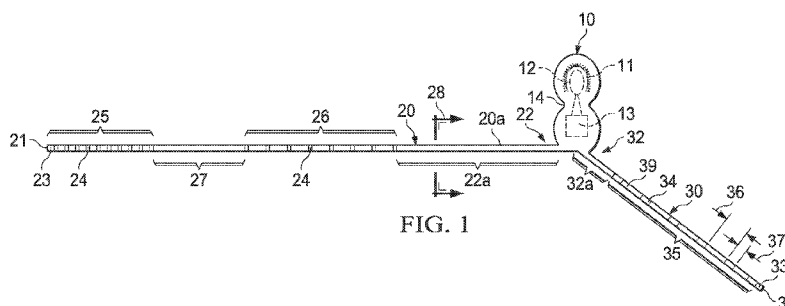

FIG. 1

(57) Abstract: An implantable head-mounted unibody peripheral neurostimulation system is provided for implantation in the head for the purpose of treating chronic head pain, including migraine. The system may include an implantable pulse generator (IPG) from which multiple stimulating leads may extend sufficient to allow for adequate stimulation over multiple regions of the head, preferably including the frontal, parietal and occipital regions. A lead may include an extended body, along which may be disposed a plurality of surface metal electrodes, which may be sub-divided into a plurality of electrode arrays. A plurality of internal metal wires may run a portion of its length and connect the IPG's internal circuit to the surface metal electrodes. The IPG may include a rechargeable battery, an antenna, and an application specific integrated circuit. The IPG may be capable of functional connection with an external radiofrequency unit for purposes that may include recharging, diagnostic evaluation, and programming.



IMPLANTABLE HEAD MOUNTED NEUROSTIMULATION SYSTEM  
FOR HEAD PAIN

5

**CROSS-REFERENCE TO RELATED APPLICATIONS**

[0001] This application claims priority to U.S. Application No. 14/460,139, filed August 14, 2014, entitled IMPLANTABLE HEAD MOUNTED NEUROSTIMULATION SYSTEM FOR HEAD PAIN, and to U.S. Provisional Application No. 61/894,795, filed October 23, 10 2013, entitled IMPLANTABLE HEAD MOUNTED NEUROSTIMULATION SYSTEM FOR HEAD PAIN, the specifications of which are incorporated by reference herein in their entirety. This application is related to U.S. Patent Application No. 14/460,111, filed August 14, 2014, entitled IMPLANTABLE NEUROSTIMULATION LEAD FOR HEAD PAIN, which claims benefit of U.S. Provisional Application No. 61/865,893, filed August 14, 2013, 15 the specifications of which are incorporated by reference herein in their entirety.

**TECHNICAL FIELD**

[0002] The present disclosure relates generally to a fully head mounted implantable neurostimulation system and methods of treating migraine headaches and other forms of chronic head pain.

20

**BACKGROUND**

[0003] Neurostimulation systems comprising implantable neurostimulation leads are used to treat chronic pain. Conventional implantable peripheral neurostimulation leads are designed for placement in the spinal canal as part of a spinal cord stimulation system, and for  
5 the therapeutic purpose of treating various forms of chronic back and extremity pain.

**SUMMARY**

[0004] In various implementations, an implantable head-mounted, unibody peripheral nerve stimulation system may be configured for implantation of substantially all electronics, including an on-site battery, at or near the implanted electrodes on the skull. The system may  
5 include an implantable pulse generator (IPG) from which two neurostimulating leads may extend to a length sufficient to provide therapeutic neurostimulation unilaterally over the frontal, parietal and occipital regions of the hemicranium. The system may be operable to provide medically acceptable therapeutic neurostimulation to multiple regions of the head, including the frontal, parietal and occipital regions of the hemicranium, substantially  
10 simultaneously.

[0005] Each of the leads may include an extended lead body; a plurality of surface metal electrodes disposed along the lead body, which may be divided into two or more electrode arrays; and a plurality of internal electrically conducting metal wires running along at least a  
15 portion of the length of the lead body and individually connecting an internal circuit of the IPG to individual surface metal electrodes. The extended lead body may comprise a medical grade plastic. The IPG may include a rechargeable battery, an antenna coil, and an application specific integrated circuit (ASIC). The IPG may be configured for functionally connecting with an external radiofrequency unit. The external radiofrequency unit may be operable to perform various functions including recharging the rechargeable battery,  
20 diagnostically evaluating the IPG, and programming the IPG.

[0006] Implementations may include one or more of the following features. The IPG may be of proper aspect ratio with respect to the specific site of intended implantation in the head, such as an area posterior to and/or superior to the ear. There may be an external portable programming unit that is capable of achieving a radiofrequency couple to the  
25 implanted IPG. The IPG may have a rechargeable battery as a power source. The rechargeable battery may be inductively recharged through the skin.

[0007] Implementations may include one or more of the following features. A neurostimulating lead may not include a central channel for a stylet. A neurostimulating lead may have a smaller diameter than conventional leads.

[0008] Implementations may include one or more of the following features. The system may include the disposition of a sufficient plurality of surface electrodes over a sufficient linear distance along the neurostimulating leads to enable medically adequate therapeutic stimulation across multiple regions of the head, including the frontal, parietal, and occipital region of the hemicranium substantially simultaneously. The extended array of surface electrodes may be divided into two or more discrete terminal surface electrode arrays. The linear layout of the multiple surface electrode arrays may include at least one array positioned over the frontal region, at least one array positioned over the parietal region, and at least one array positioned over the occipital region.

5 [0009] Specific intra-array design features may include variations in the specific number of electrodes allotted to each group; the shape of the electrodes, e.g., whether the electrodes are cylindrical or flattened; the width of each electrode within each array, and the linear distance intervals of separation of the electrodes within each array.

[0010] Various implementations may include a plurality of connection ports that can be connected with a plurality of leads and thus allow for attaching additional leads.

15 [0011] In various implementations, methods of treating chronic pain may include methods of treating chronic head and/or face pain of multiple etiologies, including migraine headaches; and other primary headaches, including cluster headaches, hemicrania continua headaches, tension type headaches, chronic daily headaches; further including secondary headaches, such as cervicogenic headaches and other secondary musculoskeletal headaches.

[0012] In various implementations, methods of treating chronic pain may include methods of treating head and/or face pain of multiple etiologies, including neuropathic head and/or face pain, nociceptive head and/or face pain, and/or sympathetic related head and/or face pain.

25 [0013] In various implementations, methods of treating chronic pain may include methods of treating head and/or face pain of multiple etiologies, including greater occipital neuralgia, as well as the other various occipital neuralgias, supraorbital neuralgia, auriculo-temporal neuralgia, infraorbital neuralgia, and other trigeminal neuralgias, and other head and face neuralgias.

[0014] The details of one or more implementations are set forth in the accompanying drawings and the description below. Other features, objects, and advantages of the implementations will be apparent from the description and drawings.

**BRIEF DESCRIPTION OF THE DRAWINGS**

[0015] For a more complete understanding of this disclosure and its features, reference is now made to the following description, taken in conjunction with the accompanying drawings, in which:

5 [0016] Fig. 1 depicts a side view of a head-mounted, unibody neurostimulator system for migraine and other head pain. The system features an implantable pulse generator (IPG) from which two neurostimulating leads extend – a Fronto-Parietal Lead (FPL) and an Occipital Lead (OL). Each lead includes a plurality of electrodes in a distribution and over a length to allow full unilateral coverage of the frontal, parietal, and occipital portions of the head.

10 [0017] Fig. 2 depicts a side view of a Frontal Electrode Array (FEA) with Internal Wires. The FEA is disposed over the distal portion (such as 8-10 cm) of the FPL, which anatomically places it over the frontal region, and specifically over the supraorbital nerve and other adjacent nerves of the region. In general the layout, disposition and connections of the Internal Wires and Surface Electrodes disposed over the Parietal Electrode Array (PEA) and  
15 the Occipital Electrode Array (OEA) are the same as that depicted for the FEA.

[0018] Fig. 3 depicts a side view of the Internal Wires exiting from the IPG's Internal Circuit enroute to the Surface Electrodes disposed over the FPL and the OL.

[0019] Fig. 4 depicts a cross-sectional view of a Lead Central Body comprising a Cylindrical Lead Body (with Internal Wires) between the IPG Internal Circuit and the Lead  
20 Surface Electrodes.

[0020] Fig. 5 depicts a rear view of a Head with a full Head-Mounted Neurostimulator System In-Situ. Prominent here is the OL depicted passing from the IPG caudally and medially across the occipital region, whereby the OEA is disposed in a fashion to cross over and cover the major associated nerves -- primarily the greater occipital nerve, but typically  
25 including the lesser and/or third occipital nerve as well. Also depicted are the PEA and the FEA of the FPL as they cross and cover the primary nerves of the Parietal Region, including the auriculo-temporal nerve, and the Frontal Region, including the supraorbital nerve.

[0021] Fig. 6 depicts a side view of a Head with a full Head-Mounted Neurostimulator System In-Situ. Prominent here is the PEA, as it covers a portion of the Parietal Region and the major associated nerves, including the auriculo-temporal nerve, as well as adjacent cutaneous nerves. Also depicted are the courses of the distal portion of the FPL and the OL,  
5 as they pass over and cover the associated nerves of the Frontal (Supraorbital) and Occipital Regions.

[0022] Fig. 7 depicts a front view of a Head with a full Head-Mounted Neurostimulator System In-Situ. Prominent here is the FEA, as it covers a portion of the Frontal (Supraorbital) Region and the major associated nerves – primarily the supraorbital nerve, but  
10 also commonly the greater trochlear nerve, as well as adjacent nerves. Also depicted is the course of the parietal portion of the FL.



**[0023] INDEX OF ELEMENTS**

- 10: Implantable Pulse Generator**  
 11: Antenna  
 12: Battery  
 5 13: Application Specific Integrated Circuit  
 14: Medical Plastic Cover
- 20: Fronto-Parietal Lead**  
 20a: Plastic Body Member  
 10 21: Distal End  
 22: Proximal End  
 22a: Proximal Lead Segment  
 23: Distal Non-Stimulating Tip  
 24: Surface Metal Electrode  
 15 25: Frontal Electrode Array  
 26: Parietal Electrode Array  
 27: Inter-Array Interval  
 28: Point of Cross Section FIG 4  
 29: Lead Internal Wire  
 20
- 30: Occipital Lead**  
 31: Distal End  
 32: Proximal End  
 32a: Proximal Lead Segment  
 25 33: Distal Non-Stimulating Tip  
 34: Surface Metal Electrode  
 35: Occipital Electrode Array  
 36: Interelectrode Distance  
 37: Surface Electrode Width  
 30 38: Lead Internal Wire  
 39: Plastic Body Member
- 50: Occipital Region of Head**  
 51: Greater Occipital Nerve  
 35 52: Lesser Occipital Nerve  
 53: Third Occipital Nerve
- 60: Parietal Region of Head**  
 61: Auriculotemporal Nerve  
 40
- 70: Frontal Region of Head**  
 71: Supraorbital Nerve

**DETAILED DESCRIPTION**

[0024] Referring now to the drawings, wherein like reference numbers are used herein to designate like elements throughout, the various views and embodiments of implantable head mounted neurostimulation system for head pain are illustrated and described, and other possible embodiments are described. The figures are not necessarily drawn to scale, and in some instances the drawings have been exaggerated and/or simplified in places for illustrative purposes only. One of ordinary skill in the art will appreciate the many possible applications and variations based on the following examples of possible embodiments.

**A. Introduction**

10 [0025] The present disclosure provides a fully head mounted implantable peripheral neurostimulation system designed for the treatment of chronic head pain. It incorporates multiple elements and features that take into account the unique anatomic, physiologic, and other related challenges of treating head pain with implantable neurostimulation, thereby greatly improving on therapeutic response, patient safety, medical risk, and medical costs, 15 which combine to improve overall patient satisfaction.

[0026] Prior implantable peripheral neurostimulation systems and components, including leads and pulse generators, have been designed and developed specifically as spinal cord stimulator systems and for the specific therapeutic purpose of treating chronic back and extremity pain. Over the years, these spinal cord stimulators were ultimately adopted and adapted for use as implantable peripheral nerve stimulators for the treatment of migraine 20 headaches, and other forms of chronic head pain; however, they were so utilized with full recognition of the inherent risks and limitations given that they were developed only to address, and accommodate to, the unique anatomic and physiologic features of the back and chronic back pain.

25 [0027] U.S. Provisional Patent Application Serial No 61/865,893 describes the manifold problems associated with the application of spinal cord stimulators for head pain as fundamentally due to design flaws associated with, and inherent to, the use of an implantable therapeutic device in an area of the body that it was not designed for.

[0028] Indeed, the anatomy of the head, and the pathophysiology of headaches, and other forms of head pain, are so significantly different from the anatomy of the spinal canal, and pathophysiology of chronic back pain, that when spinal cord stimulators are utilized for cranial implants, the clinical problems associated with these differences manifest themselves. 5  
Importantly, these well-documented problems are clinically very significant and include issues of patient safety and satisfaction, the risk of an inadequate, or suboptimal, therapeutic response; and issues with patient comfort and cosmetics; as well as a recognized increased risk of surgical complications and technical problems.

[0029] These medical issues stem from the design of conventional leads and the IPG. 10  
Conventional lead designs include a relatively large diameter, a cylindrical shape, (often) inadequate length and the necessity of implanting the IPG in the torso and distant from the distal leads, and a number and disposition of the surface electrodes and active lead arrays that do not match the requirements. A cylindrical lead of relatively large diameter results in increased pressure on, and manifest tenting of, the overlying skin, particularly of the 15  
forehead. Because conventional leads are of inadequate length to extend from the head to the IPG implant site, commonly in the lower back, abdomen, or gluteal region, lead extensions are often employed, and there are attendant risks of infection, local discomfort, and cosmetic concerns.

[0030] With respect to prior leads: 1) There is only a single array of electrodes, with 20  
common lead options including 4, 8, or 16 electrodes disposed over that single array; 2) The array is relatively short with most leads having an array of from 5-12 cm in length; 3) Within this single array, the individual electrodes are disposed uniformly with constant, equal inter-electrode distances. This results in the need to implant multiple (often four or more) of the conventional leads to adequately cover the painful regions of the head.

[0031] There are several practical clinical outcomes that result from the use of prior leads 25  
for the treatment of chronic head pain. First, since they comprise a single, relatively short active array, the currently available leads provide therapeutic stimulation to only a single region of the head; that is, they can provide stimulation to only the frontal region, or a portion of the parietal region, or a portion of the occipital region. Therefore, if a patient has pain that 30  
extends over multiple regions, then multiple separate lead implants are required – basically one lead implant is required for each unilateral region. A great majority of patients with

chronic headaches experience holocephalic pain; that is they experience pain over the frontal and parietal and occipital regions bilaterally. Therefore, commonly these patients will need 4 to 7 leads implanted to achieve adequate therapeutic results (2 or 3 leads on each side).

5 [0032] Second, the need for multiple leads includes considerable added expense, and more importantly, added medical risk associated with adverse events attendant to the multiple surgical procedures. Such adverse events include an increased risk of infection, bleeding, and technical issues with the leads, e.g., lead fracture, lead migration, and local irritation.

10 [0033] Third, as the clinical database discloses, the inter-electrode spacing may be of central therapeutic significance. That is, for example, whereas commonly pain over the occipital region is consistently effectively treated by quadripolar leads (leads with four evenly spaced electrodes) that have the electrodes relatively widely spaced apart (approximately a cm or more apart), clinically it is often found that electrodes configurations that are more narrowly spaced may be more effective over the supraorbital nerve and regions. Thus, a quadripolar lead that has the electrodes only 1-2 mm apart may be more effective in this  
15 region, as it allows for more precise control of the delivered electrical pulse wave delivery.

[0034] Inter-electrode spacing is also of therapeutic significance. For example, whereas pain over the occipital region is commonly treated effectively by systems incorporating relatively widely-spaced quadripolar leads (four electrodes at approximately 1 cm or more intervals), more narrowly spaced contacts are often more effective over the supraorbital  
20 region.

[0035] When an IPG implant designed for spinal cord stimulation systems is employed as a peripheral nerve stimulator for head pain, several outcomes result. First, the IPG is implanted at a considerable anatomic distance for the cranial lead implants. Indeed, the leads must pass from their distal cranial implant positions across the cervical region and upper back  
25 to the IPG implant location, which are most commonly in the lower back, lower abdomen, or gluteal region. The leads must cross multiple anatomic motion segments, including the neck and upper back and/or chest at a minimum, and commonly include the mid back, lower back and waist segments, as well. The simple motions of normal daily life produce adverse tension and torque forces on the leads across these motion segments, which in turn increases  
30 the risk of various outcomes, including lead migration and/or lead fracture. In addition, the

relatively large size of a spinal cord stimulator IPG contributes to local discomfort, cosmetic concerns, and increased risk of infection that may become larger and harder to treat in proportion to the size of the IPG pocket.

5 [0036] The present disclosure is directed to an implantable head-mounted unibody peripheral neurostimulation system that includes an IPG from which two neurostimulating leads extend to a length sufficient to allow for therapeutic neurostimulation unilaterally over the frontal, parietal and occipital regions of the head.

10 [0037] The present disclosure addresses and effectively solves problems attendant to publically available leads. The most important of these is the fact that current leads can only adequately stimulate a single region of the head due to design element flaws associated with terminal surface electrode number and disposition. The disclosure additionally addresses and solves other problems inherent with the currently available leads, including problems with cosmetics and patient comfort, particularly over the frontal regions, due the uncomfortable pressure placed on the skin of the forehead, due the cylindrical shape and relatively large diameter of the distal portion of the lead. Finally, the lead of the present disclosure solves the 15 currently available leads' problem of inadequate lead length to reach a gluteal location of the implantable pulse generator, which therefore necessitates the additional risk and expense of further surgery to implant lead extensions.

20 [0038] In one aspect, the implantable, head-mounted, neurostimulation system for head pain is operable for implantation in the head, and to provide neurostimulation therapy for chronic head pain, including chronic head pain caused by migraine and other headaches, as well as chronic head pain due other etiologies. The peripheral neurostimulator system disclosed herein takes into account unique anatomic features of the human head, as well as the unique, or singular, features of the various pathologies that give rise to head pain, 25 including migraine and other headaches, as well as other forms of chronic head pain. To date, all commercially available systems that have been clinically utilized for implantation as a peripheral neurostimulator system were actually originally designed specifically for placement in the epidural space, as part of a spinal cord stimulation system, for the therapeutic purpose of treating chronic back and/or extremity pain. Thus, there are currently 30 no commercially available leads or fully system that have designs in the public domain, that have been designed and developed for use in the head and for head pain.

[0039] In another aspect, the implantable, head-mounted, neurostimulation system for head pain comprises multiple design features, including disposition of a sufficient plurality of surface electrodes over a sufficient linear distance along the distal lead, such as will result in lead that, as a single lead, is capable of providing medically adequate therapeutic stimulation over the entire hemispheric region; that is, over the frontal, parietal, and occipital region substantially simultaneously. Currently available systems, which were designed specifically for epidural placement for chronic back pain, are capable of only providing stimulation over a single region; that is over either the frontal region alone, or the parietal region alone, or the occipital region alone.

[0040] In yet another aspect, the implantable, head-mounted, neurostimulation system for head pain comprises multiple design features, including the physical grouping of the extended array of surface electrodes into three or more discrete terminal surface electrode arrays. The linear layout of these two or more (preferably three or more) surface electrodes arrays is designed such that following implantation there would be at least one array positioned over the frontal region, at least one array positioned over the parietal region, and at least one array positioned over the occipital region. This feature further improves upon therapeutic effectiveness of the extended terminal surface electrode array sufficient for hemispheric stimulation by allowing for more precise control of the therapeutic neurostimulation parameters.

[0041] In still another aspect, the implantable, head-mounted, neurostimulation system for head pain comprises multiple design features, including incorporating individual design features within each of the three or more individual surface electrode arrays; examples of such intra-array design features would include the specific number of electrodes allotted to each group; whether the electrodes are cylindrical or flattened; the width of each electrode within each array, and the linear distance intervals of separation of the electrodes within each array. This feature further improves upon therapeutic effectiveness of the extended terminal surface electrode array sufficient for hemispheric stimulation, and the grouping of these electrodes into three or more separate surface electrode arrays, by providing each specific array location a unique intra-array design that takes into account, and thereby seeks to optimize, design elements that are known to be possibly or likely beneficial to the therapeutic end result, given the anticipated post-implant anatomic location of that array.

[0042] In yet another aspect, the implantable, head-mounted, neurostimulation system for head pain comprises multiple novel design features, including incorporating individual design features into a single lead design and thereby achieving additive benefits.

[0043] In still another aspect, an implantable, head-mounted, neurostimulation system for head pain results in a marked decrease in the number of separate lead implants required to adequately treat a single patient. A single implant will provide the same therapeutic anatomic coverage that it would take the implantation of three or four of the currently available leads; that is instead of the current which often calls for three or more leads to be implanted to provide adequate hemispheric coverage, the same anatomic region may be covered with a single stimulator lead implant. The lead provides extended coverage over the full hemisphere; that is achieving medically acceptable neurostimulation unilaterally over the frontal, parietal, and occipital regions simultaneously. In contrast, publicly known leads are able to consistently provide medically acceptable neurostimulation therapy only over a single region; meaning that it would require three separate surgically placed lead implants to achieve the same therapeutic coverage of a single implant of a lead of the present disclosure. This will decrease the total number of surgeries required, as well as the extent of each individual surgery, for many patients.

[0044] In another aspect, the present disclosure is directed to a system that is fully localized to the head, which obviates the requirement of currently available systems of having long leads and extensions extending across the neck and back to IPG locations commonly in the low back and gluteal region, and thereby decreases the risk of problems attendant to such long leads and extensions, including discomfort, infection, technical extension issues such as fracture, and other morbidities. This ultimately results in a decreased number of surgeries required by a patient.

[0045] In other aspects the system may include one or more of the following features. A neurostimulating lead may not require a central channel for a stylet. A neurostimulating lead may have a smaller diameter than currently available leads.

[0046] In other aspects the system may include one or more of the following features. The system may include the disposition of a sufficient plurality of surface electrodes over a sufficient linear distance along the system's leads to enable medically adequate therapeutic

stimulation across multiple regions of the head, and preferably the entire hemicranium; that is, over the frontal, parietal, and occipital region simultaneously. The extended array of surface electrodes may be divided into two or more discrete terminal surface electrode arrays. The preferred linear layout of these multiple surface electrode arrays includes at least one  
5 array positioned over the frontal region, at least one array positioned over the parietal region, and at least one array positioned over the occipital region.

[0047] In other aspects intra-array design features may include variations in the specific number of electrodes allotted to each group; the shape of the electrodes, e.g., whether the electrodes are cylindrical or flattened; the width of each electrode within each array, and the  
10 linear distance intervals of separation of the electrodes within each array.

[0048] In other aspects, the system may a plurality of connection ports that can be connected with a plurality of leads and thus allow for attaching additional leads should they later be required.

[0049] In another aspect, an implantable, head-mounted, neurostimulation system for  
15 head pain comprises multiple design features; including features aimed at improving patient safety by improving the incidence of adverse events, including the risk of infection, as well as the risk and incidence of known technical problems associated with implanted leads, including lead migration and lead fracture, amongst others. The lead may comprise two or more (i.e. three or more) surface electrode arrays, each uniquely designed, that are disposed  
20 over a sufficient lead length to allow for medically acceptable therapeutic neurostimulator coverage of at least regions within the supraorbital, parietal, and occipital cranial regions. To achieve the same clinical coverage from a single implant, it would require three or more separately surgically implanted leads. Therefore, by reducing the number of surgical incisions, as well as the number of surgically implanted leads, the associated risks of adverse  
25 events are proportionally diminished.

[0050] In yet another aspect, an implantable, head-mounted, neurostimulation system for head pain may treat chronic head and/or face pain of multiple etiologies, including migraine headaches; and other primary headaches, including cluster headaches, hemicrania continua headaches, tension type headaches, chronic daily headaches, transformed migraine  
30 headaches; further including secondary headaches, such as cervicogenic headaches and other



secondary musculoskeletal headaches; including neuropathic head and/or face pain, nociceptive head and/or face pain, and/or sympathetic related head and/or face pain; including greater occipital neuralgia, as well as the other various occipital neuralgias, supraorbital neuralgia, auriculotemporal neuralgia, infraorbital neuralgia, and other  
5 trigeminal neuralgias, and other head and face neuralgias.

[0051] In other aspects, an implantable, head-mounted, neurostimulation system for head pain may not require a central channel for stylet placement over its distal (frontal) portions. The lead may improve patient comfort and cosmetics by virtue of its relatively small diameter over the distal portions of the lead, partially due the lack of a central stylet channel, as well as  
10 due to a progressive decrease in the number of internal wires continuing after each terminal electrode. The lead may further improve cosmetic appearance and patient comfort by incorporating a flattened lead design for that portion of the lead expected to be over the frontal portion of the head.

[0052] Thus the present disclosure provides for a peripheral neurostimulation lead that is  
15 uniquely designed for implantation in the head as a therapy for chronic head pain, and is designed to solve the known design issues associated with current leads, as the lead of the present disclosure seeks to optimize the therapeutic response, improve patient comfort, improve cosmetics, reduce the number of surgical leads required, reduce medical risk, and reduce medical costs.

## 20 **B. Overview**

[0053] Turning now to the drawings, which depict the system and several of its components in various aspects and views, and in which similar reference numerals denote similar elements. The drawings illustrate an IPG from which two neurostimulating leads may extend to a length sufficient to allow for therapeutic neurostimulation unilaterally over the  
25 frontal, parietal and occipital regions. The leads include an extended plastic lead body; a plurality of surface metal electrodes disposed along the lead, which may be divided into two or more electrode arrays; a plurality of internal electrically conducting metal wires running along at least a portion of its length and individually connecting the IPG's internal circuit to individual surface metal electrodes. The implantable pulse generator includes a rechargeable  
30 battery, an antenna coil, and ASIC. The system may be operable to provide medically

acceptable therapeutic neurostimulation to multiple regions of the head, including the frontal, parietal and occipital regions simultaneously, and three figures demonstrate various views of this feature as the lead is depicted in-situ.

**C. Full Head-Mounted Neurostimulator System**

- 5 [0054] FIG 1 depicts a side view of a full neurostimulator system, which consists of an implantable pulse generator (IPG) 10 along with two unibody plastic lead extensions – a Fronto-Parietal Lead (FPL) 20 and an Occipital Lead (OL) 30 of adequate length to extend to roughly the midline of the forehead and to the midline at the cervico-cranial junction, respectively.
- 10 [0055] FIG 5, 6 and 7 depict posterior, lateral and frontal views of the system in-situ. The unit is demonstrated in an implant position where the IPG 10 is posterior and cephalad to the pinna of the ear. The drawings demonstrate the FPL 20 passing over the parietal 60 and frontal 70 regions of the head in a manner that places the FEA over the supraorbital nerve and the PEA over the auriculotemporal nerve. The OL 30 is shown passing caudally and medially
- 15 over the occipital region of the head 50 such that the OEA 35 cross over the greater occipital nerve 51, the lesser occipital nerve 52, and the third occipital nerve 53.

**D.     *Fronto-parietal Lead***

[0056]     Continuing with FIG 1, the FPL as part of the unibody construction, extends from the IPG. The FPL comprises a plastic body member 20a and a set of internal conducting wires 29.

5     [0057]     The plastic body member 20a is an elongated, cylindrical, flexible member, which may be formed of a medical grade plastic polymer. It has a proximal end 22, a distal end 21, and may be conceptually divided into five segments along its linear dimension. Progressing from the proximal end 22, these segments sequentially include a proximal lead segment (PLS) 22a, a parietal electrode array (PEA) 26, an inter-array interval 27, a frontal electrode  
10     array (FEA) 25, and a distal non-stimulating tip 33.

[0058]     The lead internal wires 29 pass along the interior of the plastic body member as depicted in FIG 4.

**E.     *Frontal Electrode Array***

[0059]     Continuing with FIG 1, the FEA 25 consists of a plurality of surface metal  
15     electrodes (SME) 24 uniformly disposed over a portion of the distal aspect of the FPL 20. Lead internal wires 29 connect to the SME 24 as depicted in FIG 2, which represents the distal four SME 24 of the lead.

### ***F. Parietal Electrode Array***

[0060] Returning to FIG 1, the PEA 26 consists of a plurality of SME 24 uniformly disposed along a linear portion of the FPL. The PEA 26 is separated along the FPL from the FEA by an inter-array interval 27. It is separated only the lead from the IPG by the PLS 22a.  
5 The lead internal wires 29 connect to the individual SME 24 of the PEA in the same fashion as the do with the SME of the FEA as shown in FIG 2.

### ***G. Occipital Lead***

[0061] Continuing with FIG 1, the occipital lead (OL) 30 as part of the unibody construction, extends from the IPG 10. It comprises a plastic body member 39 and a set of  
10 lead internal wires 38 that pass through the central cylinder of the lead to connect to a series of SME 37 that are uniformly disposed along a portion of the length of the lead. These lead internal wires 38 pass and connect in the same manner as described above for the SME 24 of the FEA 25 as depicted in FIG 2 and FIG 4.

[0062] The plastic body member 39 is an elongated, cylindrical, flexible member, which  
15 may be formed of a medical grade plastic polymer. It has a proximal end 32 and a distal end 31. Progressing along the lead from the proximal end 32, these segments sequentially include a proximal lead segment (PLS) 32a, an occipital electrode array (OEA) 35, and a distal non-stimulating tip 33.

### **H. Occipital Lead Array**

[0063] As depicted in FIG 1, the OEA 35 consists of a plurality of surface metal electrodes (SME) 34 uniformly disposed over a portion OL 30. Lead internal wires 38 connect to the SME 24 in the same fashion as depicted for the FEA as shown in FIG 2.

### 5 **I. Implantable Pulse Generator**

[0064] Referring to FIG 1 and FIG 3, the three primary physical and functional components of the IPG 10 include a rechargeable battery 12, an antenna 11, and an application specific integrated circuit (ASIC) 13, along with the necessary internal wire connections amongst these related components, as well as to the incoming lead internal wires  
10 29, 39. These individual components may be encased in a can made of a medical grade metal and plastic cover 24, which itself transitions over the exiting FPL 20 and OL 30.

### **K. Connections of Main Elements and Sub-Elements**

[0065] The system may include a unibody construction to provide physical and functional continuity of the related components and sub-components.

15 [0066] The overall mechanistic purpose of an implantable neurostimulation system is to generate and conduct a prescribed electrical pulse wave from an IPG 10 down a set of lead internal wires 29, 38 running a portion of the length of the lead to specified programmed set of SME 24, 34, whereby the current is then conducted by tissue and/or fluid to an adjacent, or nearby, set of one or more SME 24, 34, which in turn passes the signal proximally down the  
20 lead wire 29, 38 back to the IPG 10 and its ASIC 13, thus completing the circuit.

### **L. First Embodiment**

[0067] The first embodiment provides for a lead that incorporates one or more of the features outlined above and includes a head-mounted, unibody neurostimulating system comprising an IPG 10 and at least two neurostimulating leads (FPL 20 and OL 30). The  
25 system may be implanted in a manner such that the IPG 10 and two leads 20, 30 are disposed as illustrated in FIG 5, FIG 6 and FIG 7. The IPG 10 is capable of functionally connecting to

and communicating with a portable programmer and an external power source for battery recharging.

[0068] In this embodiment, the leads are constructed as described above and as depicted in the drawings. The FPL **20** is approximately 26 cm in length from its proximal end **22** to its distal end **21**. The FPL **20** has a distal non-stimulating tip of approximately 3 mm in length that abuts the FEA, which may have ten SME **24** uniformly disposed over approximately 8 cm. This is followed by an inter-array interval **27** of approximately 4 cm, then the PEA, which may include eight SME **24** uniformly disposed over approximately 6 cm, and finally a proximal lead segment **22a** that ends at the proximal end **22**, where the lead transitions to the IPG **10** and the lead internal wires **29, 38** connect to the ASIC **13**.

[0069] In this embodiment, the occipital lead may comprise a plastic body member **39** over which six SME **34** may be disposed uniformly over approximately a 10 cm length of the lead, and the lead terminates in approximately a 3 mm distal non-stimulating tip **33**.

[0070] In this embodiment, the IPG **10** comprises the elements described above and depicted in the drawings, including an ASIC **13**, a rechargeable battery **12**, and an antenna **11**, which all may be housed in a medical grade metal can with plastic cover **14**. In this embodiment the dimensions of the IPG **10** measured along the outer surface of the plastic cover **14** may be approximately 5 cm by 3 cm by 0.5 mm.

[0071] The system includes a portable programmer **40** and a portable recharging unit, both of which functionally couple to the IPG through a radiofrequency mechanism.

[0072] In this embodiment, the system is capable of handling a program from the portable programmer **40** that includes such parameters as pulse amplitude, frequency and pulse width.

#### ***M. Alternate Embodiments***

[0073] There are multiple alternate embodiments that preserve the features of the neurostimulation system disclosed herein, which include an externally rechargeable and programmable IPG, sized and configured for implantation in the head, and from which fronto-parietal and occipital leads, along with their respect surface metal electrode arrays,

extend to cover multiple regions of the head. In various embodiments, the spacing and dimensions of the electrode array(s) may be constant, or the electrode arrays may be specifically designed with respect to electrode type, dimensions, and layout for improving the therapeutic effectiveness.

5 [0074] Thus, the disclosure comprises extended electrode array designs (two or more regions by a single lead), and/or multiple arrays and optimized intra-array electrode dispositions. The disclosure also comprises lead configurations, which include the capability of a modular lead design that provides for ports on either the standard FPL and OLs. In another embodiment, the IPG receive additional separate leads, if and as necessary either at  
10 the time of initial implant or in the future.

[0075] Further, the lead lengths, along with the specific technical makeup and dimensions of the individual surface metal electrodes and electrode arrays, may be varied to include more or less than three unilateral regions of the head (occipital, parietal, and frontal) contemplated by the first embodiment. For example, a single IPG may energize and control multiple  
15 additional leads of varying lengths that ultimately could be disposed over virtually every region of the head and face bilaterally.

[0076] At least two electrodes may be included per region, and while the first embodiment calls for a total of 24 electrodes disposed over three arrays covering three different regions of the head – the occipital, parietal and frontal regions – there is no absolute  
20 limit to the maximum number of electrodes. Similarly, while the first embodiment calls for three electrode arrays, the disclosure contemplates two, or even one array (so long as the array covers at least two regions). There is also no limiting maximum for the number of arrays. Also, there may be multiple variations of design within each separate array, including for example, variations in the number, dimensions, shape, and metal composition of the  
25 individual electrodes, as well as the distance and constancy of distance between electrodes, within each array. Further, each array may have the same or completely different designs.

[0077] While the neurostimulation system has been described for implantation as a peripheral neurostimulator in the head and for head pain, it is capable of being implanted and used as a peripheral nerve stimulator over other regions of the head and face than described  
30 above and also over other peripheral nerves in the body.

**N. Operation**

[0078] When functioning; that is when the internal circuit of lead internal wires is connected to an IPG; the SME of the various arrays are programmed to function as anodes and cathodes. The generated electrical pulse wave then passes from the ASIC of the IPG to the associated internal lead wire, and ultimately to its associated terminal surface metal electrode. The current then passes a short distance from the subcutaneous tissue to a contiguous, or nearby, electrode, whereby it passes back up the lead to its associated proximal metal contact, and then back to the IPG to complete the circuit. The generated pulse waves pass through the subcutaneous tissue between two terminal electrodes that stimulates the sensory nerves of the area. When active, the IPG may be programmed to produce continuous series of pulse waves of specified frequency, amplitude, and pulse width. It is this series of pulse waves actively stimulating a patient's locally associated nerves that underpins the therapeutic effect of the implanted unit. The electrical pulse wave then passes from a connected proximal surface metal contact, along the associated internal lead wire, and ultimately to its associated terminal surface metal contact.

[0079] It is to be understood that the implementations disclosed herein are not limited to the particular systems or processes described which might, of course, vary. It is also to be understood that the terminology used herein is for the purpose of describing particular implementations only, and is not intended to be limiting. As used in this specification, the singular forms “a”, “an” and “the” include plural referents unless the content clearly indicates otherwise. In addition, the term “coupling” includes direct and/or indirect coupling of members.

[0080] Although the present disclosure has been described in detail, it should be understood that various changes, substitutions and alterations may be made herein without departing from the spirit and scope of the disclosure as defined by the appended claims. Moreover, the scope of the present application is not intended to be limited to the particular embodiments of the process, machine, manufacture, composition of matter, means, methods and steps described in the specification. As one of ordinary skill in the art will readily appreciate from the disclosure, processes, machines, manufacture, compositions of matter, means, methods, or steps, presently existing or later to be developed that perform substantially the same function or achieve substantially the same result as the corresponding



embodiments described herein may be utilized according to the present disclosure. Accordingly, the appended claims are intended to include within their scope such processes, machines, manufacture, compositions of matter, means, methods, or steps.

[0081] It will be appreciated by those skilled in the art having the benefit of this disclosure that this implantable head mounted neurostimulation system for head pain provides a unibody construction with implanted leads to cover the frontal, parietal, and occipital regions of the head. It should be understood that the drawings and detailed description herein are to be regarded in an illustrative rather than a restrictive manner, and are not intended to be limiting to the particular forms and examples disclosed. On the contrary, included are any further modifications, changes, rearrangements, substitutions, alternatives, design choices, and embodiments apparent to those of ordinary skill in the art, without departing from the spirit and scope hereof, as defined by the following claims. Thus, it is intended that the following claims be interpreted to embrace all such further modifications, changes, rearrangements, substitutions, alternatives, design choices, and embodiments.

15

**WHAT IS CLAIMED IS:**

1. A head implantable neurostimulator, comprising:
  - a main body, the main body containing:
    - a power source, and
    - 5 a processor, the processor operable to generate a plurality of stimulating signals for output on associated stimulating outputs;
    - a wire bundle having a plurality of stimulating conductors, each connected to associated ones of the stimulating outputs;
    - a first elongated lead body for containing at least a portion of the wire bundle,
    - 10 the lead body being fabricated from a flexible material;
    - a plurality of surface electrodes disposed along the length of the first elongated lead body and connected to the stimulating conductors; and
    - a covering over the main body fabricated from the flexible material and merged with the flexible material of the first elongated lead body to form a unibody
    - 15 sealed assembly comprised of the main body and the first elongated lead body.
2. The neurostimulator of Claim 1, wherein the processor and the power source in the main body are contained in a metal housing.
- 20 3. The neurostimulator of Claim 1, wherein the processor further includes communication capabilities with a wireless communication link and the main body further includes an antenna associated with the communication link.
4. The neurostimulator of Claim 1, wherein the power source comprises a battery.
- 25 5. The neurostimulator of Claim 1, wherein the processor is operable to generate the plurality of stimulating signals with a series of pulse waves of specified frequency, amplitude, and pulse width.
- 30 6. The neurostimulator of Claim 1, wherein the plurality of surface electrodes includes at least two surface electrodes, one for exciting surrounding tissue and the other for completing a circuit back to the processor.
7. The neurostimulator of Claim 6, and further comprising a plurality of surface
- 35 electrodes arranged in pairs, each pair having an exciting electrode and a returning electrode

for completing the circuit, the plurality of service electrodes forming a first array of surface electrodes.

8. The neurostimulator of Claim 7, and further comprising a second array of surface electrodes disposed in close proximity thereto, the first and second arrays of surface electrodes separated therefrom by a predetermined distance.

9. The neurostimulator of Claim 8, where in the first array of surface electrodes is operable to be associated with the supraorbital nerve bundle and associated nerves in proximity thereto and the second array of surface electrodes is operable to be associated with the parietal region and the major associated nerves, including the auriculo-temporal nerve, as well as adjacent cutaneous nerves.

10. The neurostimulator of Claim 1, and further comprising a second elongated lead body for containing the remainder of the wire bundle and fabricated from the flexible material and merged with the flexible material covering the main body and the first elongated lead body and having a plurality of surface electrodes disposed along the length thereof and connected to pairs of the stimulating conductors.

11. The neurostimulator of Claim 1, wherein the flexible material is fabricated from a medical grade plastic.

12. A unibody implantable neurostimulator, comprising:

an enclosure having a first enclosed portion and a second enclosed portion, the first enclosed portion and the second enclosed portion having a common interior;

the first enclosed portion housing having contained therein in the associated portion of the common interior:

a power source, and

a processor, the processor operable generate a plurality of stimulating signals for output on associated stimulating outputs;

the second portion having a longitudinal shape with at least one terminus and distal from the first portion and housing within the associated portion of the common interior a plurality of stimulating conductors having first and second ends, at least a portion of the stimulating conductors interfaced with associated ones of the stimulating outputs on the first and thereof; and

the second portion having a plurality of surface electrodes disposed along the length thereof at a defined spacing therebetween and each of the surface electrodes interface with a second end of an associated one of the stimulating leads.

5 13. The neurostimulator of Claim 12, wherein the first portion is shaped to facilitate subdermal implantation posterior and cephalad to the pinna of the ear.

14. The neurostimulator of Claim 13, wherein the second portion is dimensioned to facilitate subdermal implantation and extend from the first portion subdermally across the  
10 parietal bone to extend the terminus across the frontal bone.

15. The neurostimulator of Claim 14, wherein the surface electrodes are arranged in at least one first grouping of surface electrodes as a first array dispersed over and proximate to the frontal bone such that they are associated with the supraorbital nerve bundle and  
15 associated nerves in proximity thereto.

16. The neurostimulator of claim 14, wherein the second portion has a second grouping of surface electrodes disposed thereon as a second array in the position such that the second array of surface electrodes are dispersed over and proximate to the parietal bone and the  
20 major associated nerves, including the auriculo-temporal nerve, as well as adjacent cutaneous nerves.

17. The neurostimulator of Claim 14, wherein the first portion includes at least a second terminus distal from the at least one terminus and the first portion, wherein ones of the  
25 surface electrodes are disposed on the surface of the second portion between the first portion and the second terminus and the second portion between the first portion and the second terminus dimension to facilitate subdermal implantation and extend from the first portion across the occipital bone.

30 18. The neurostimulator of Claim 17, wherein:

the surface electrodes are arranged in at least one first grouping of surface electrodes as a first array dispersed over and proximate to the frontal bone such that they are associated with the supraorbital nerve bundle and associated nerves in proximity thereto;

5 wherein the second portion has a second grouping of surface electrodes disposed thereon as a second array in the position such that the second array of surface electrodes are dispersed over and proximate to the parietal bone and the major associated nerves, including the auriculo-temporal nerve, as well as adjacent cutaneous nerves; and

10 wherein the second portion has a third grouping of surface electrodes disposed thereon as a third array in the position such that the third array of surface electrodes are dispersed over and proximate to the occipital bone and the associated nerves, including at least one of the greater occipital to nerve, the lesser occipital nerve and third possible nerve.

19. The neurostimulator of Claim 12, wherein the enclosure is flexible.

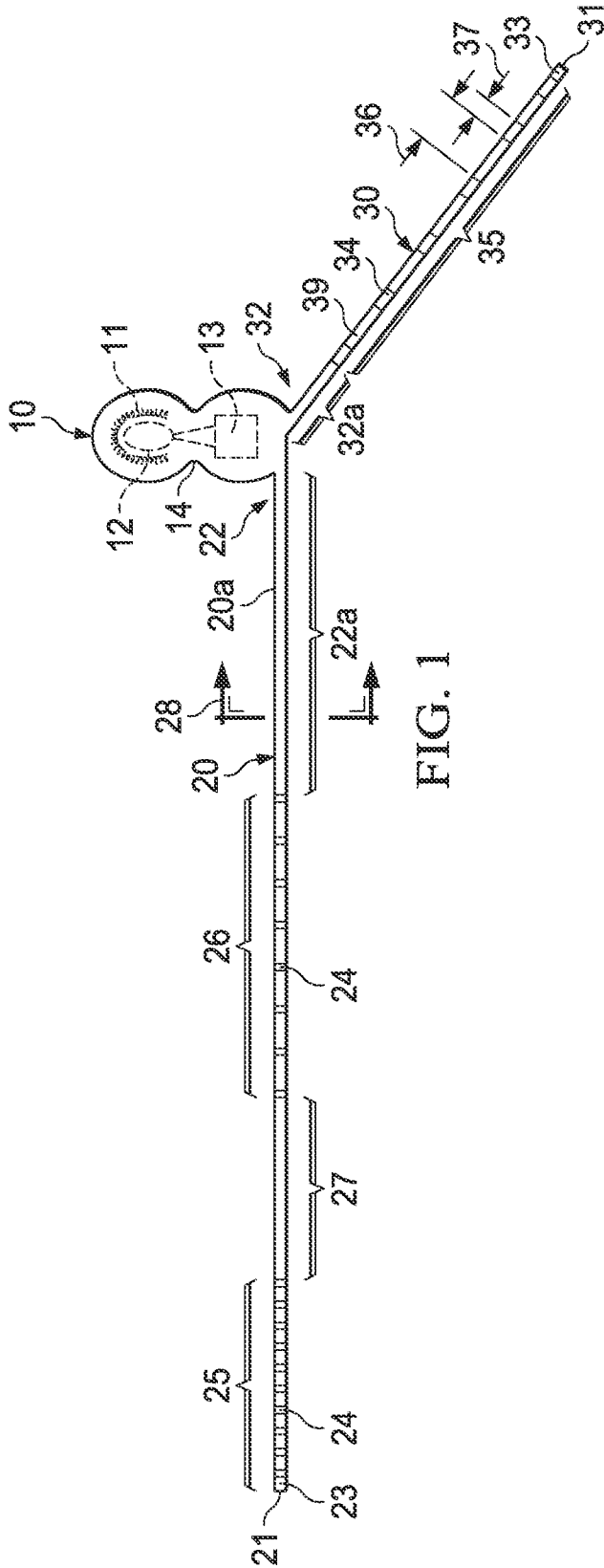

FIG. 1

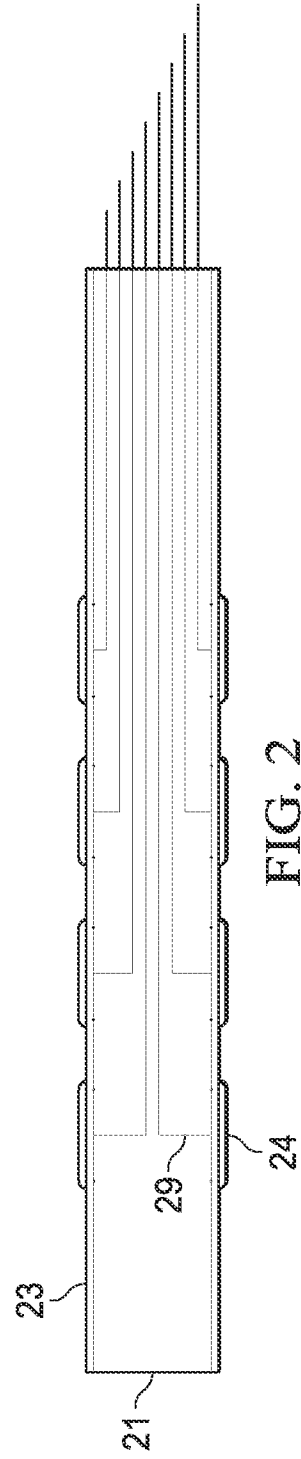
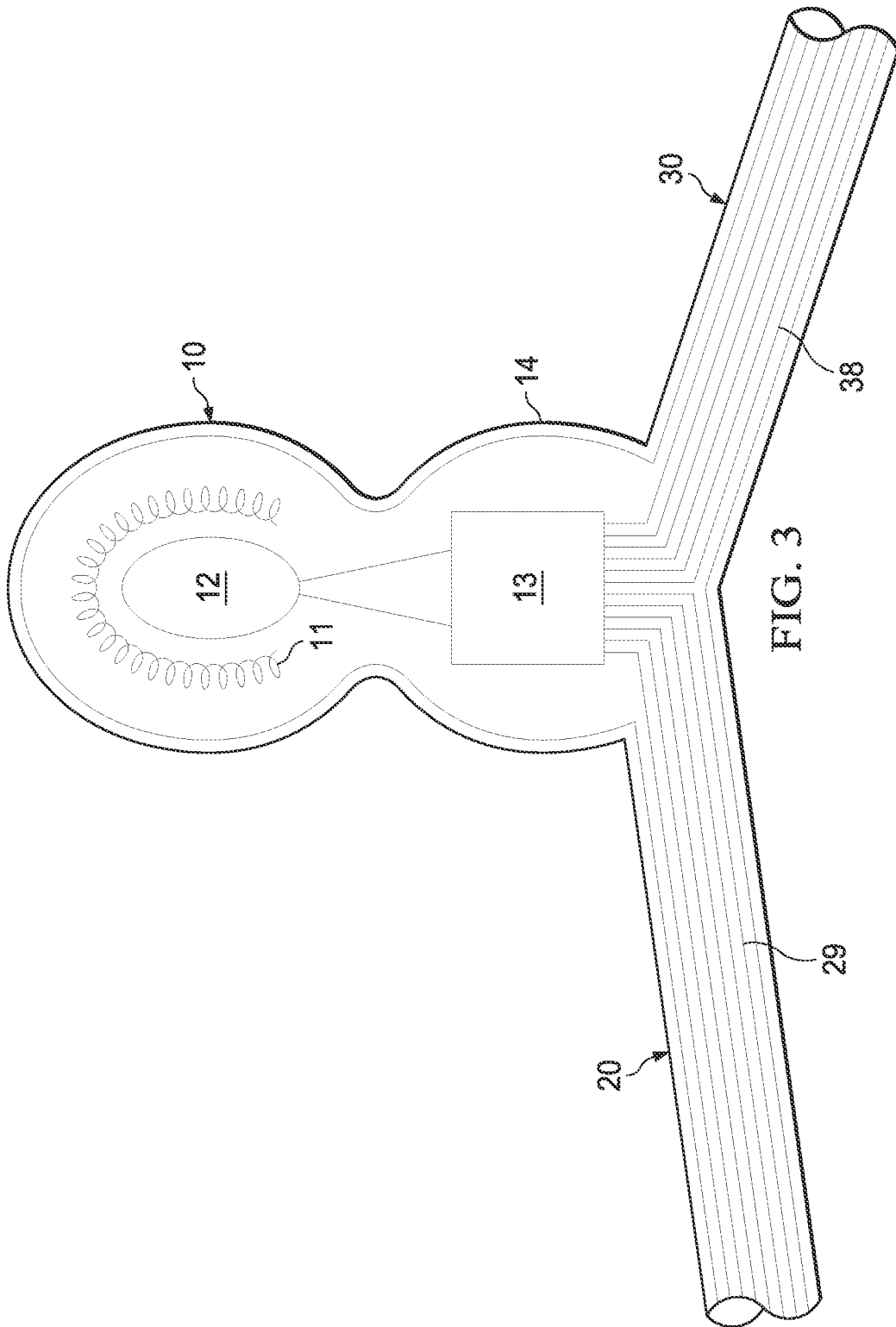

FIG. 2



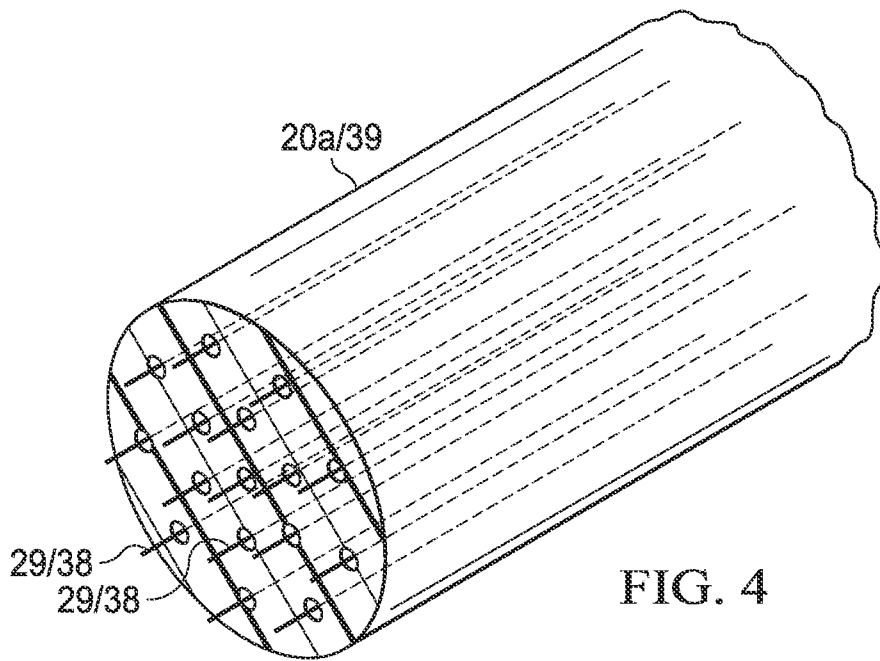

FIG. 4



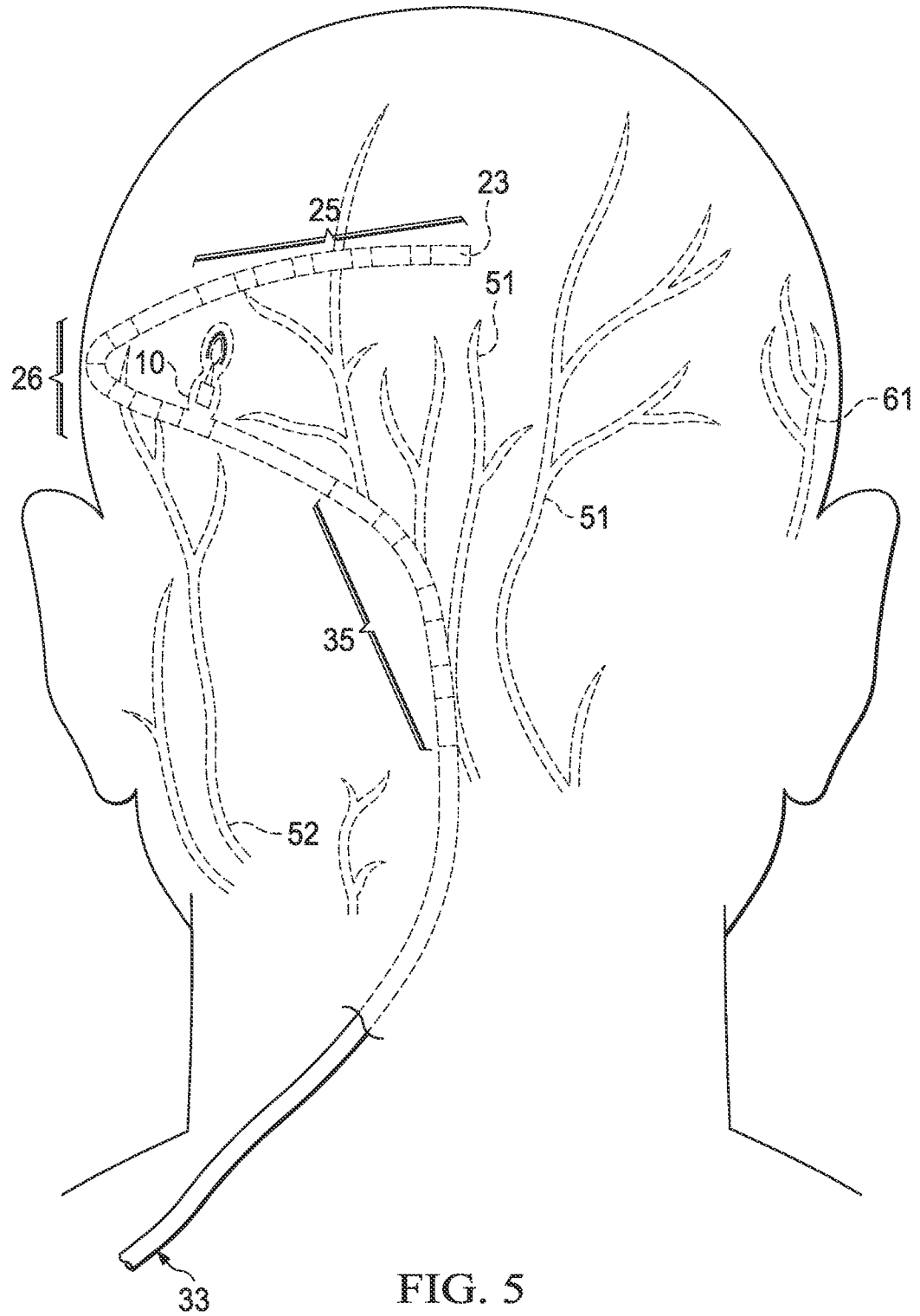

FIG. 5

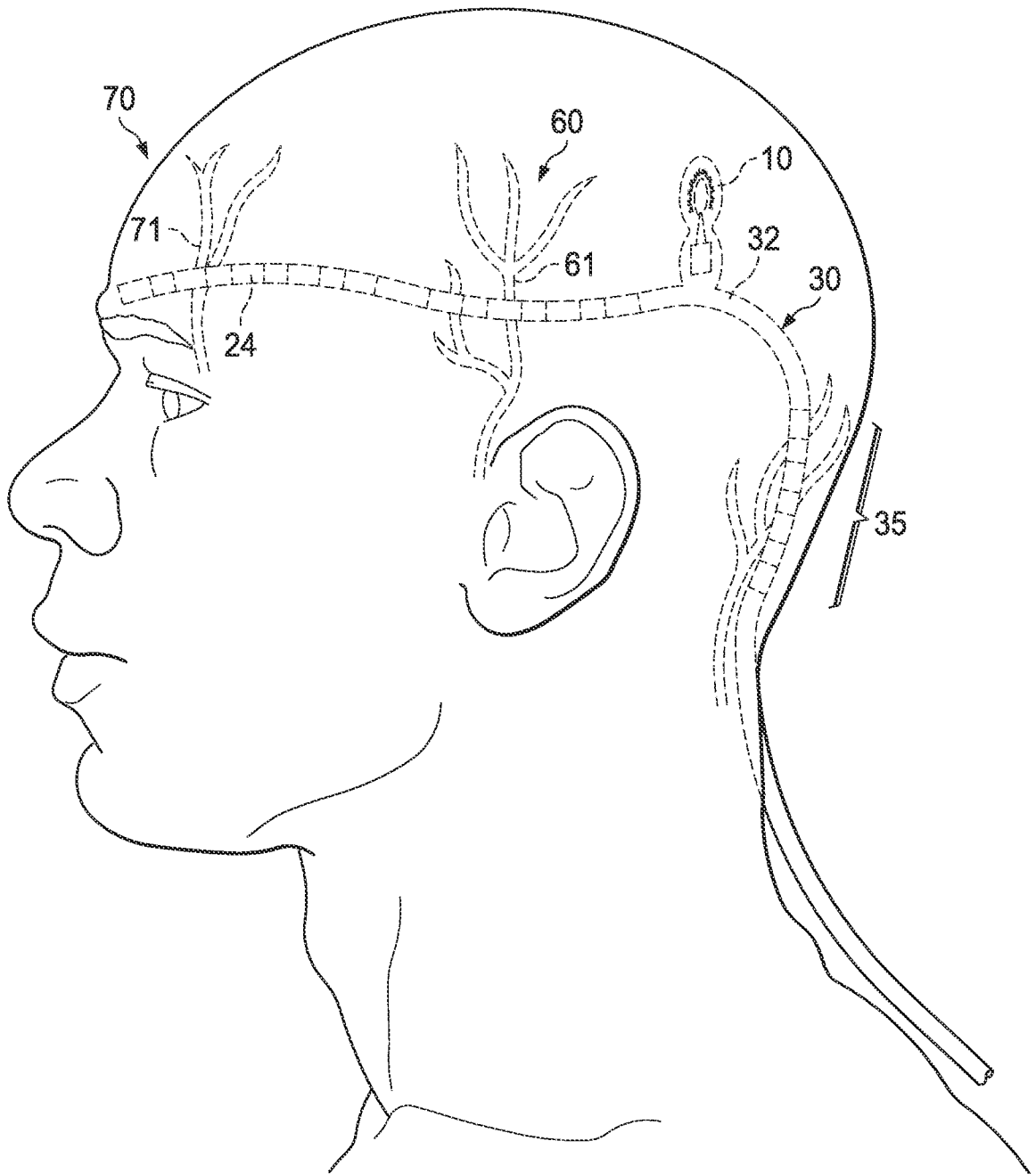

FIG. 6

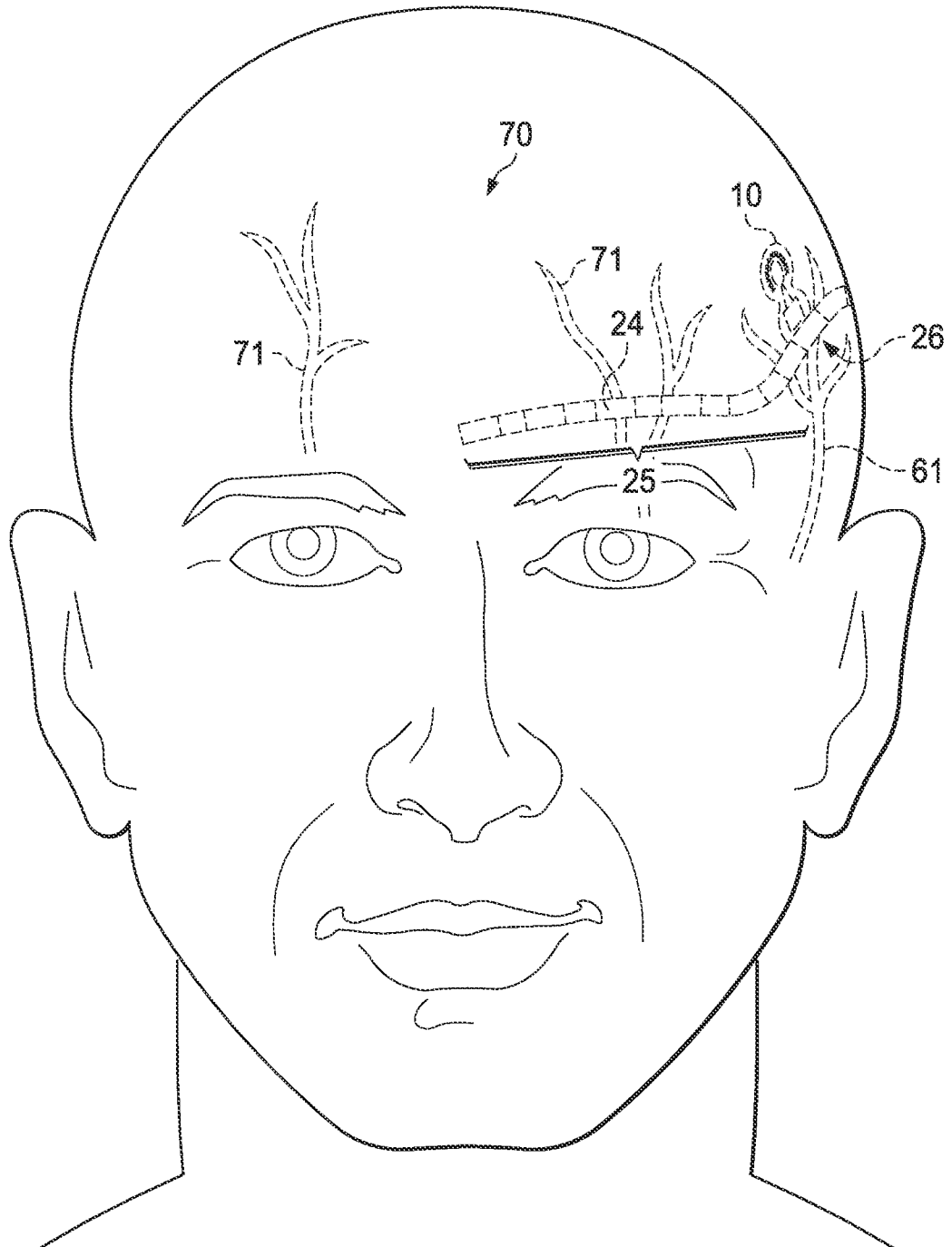

FIG. 7