

Aug. 22, 1961

O. J. POUPITCH
CONTAINER-CARRIER DEVICE

2,997,169

Filed Feb. 6, 1958

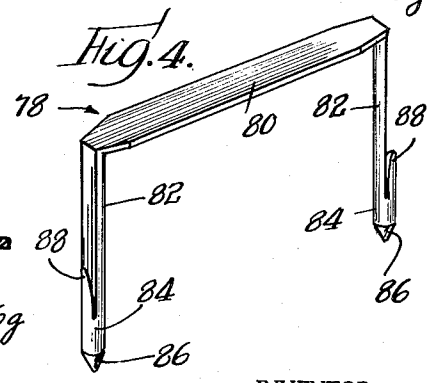
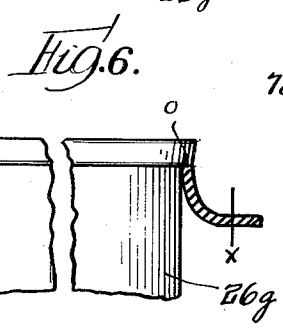
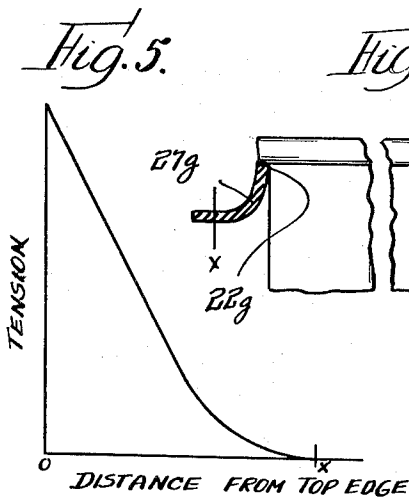
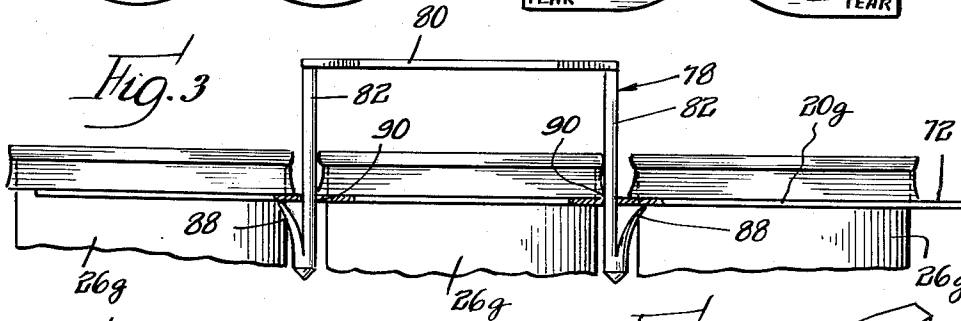
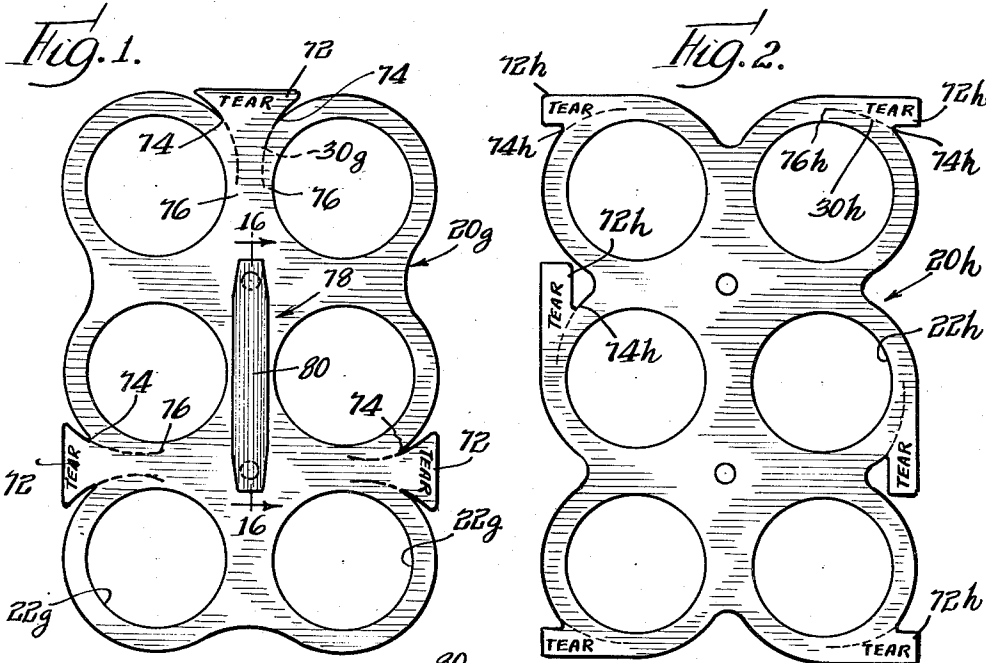

INVENTOR.
Ougljesa Jules Poupitch
BY
Olson & Truller
Attys.

1

2,997,169

CONTAINER-CARRIER DEVICE

Ougljesa Jules Poupitch, Itasca, Ill., assignor to Illinois Tool Works, Chicago, Ill., a corporation of Illinois
 Filed Feb. 6, 1958, Ser. No. 713,692
 3 Claims. (Cl. 206-65)

This invention is concerned generally with the art of carriers for containers such as cans, bottles, and the like.

In my application Serial Number 642,081 filed February 25, 1957, for "Can Carrier Device," now abandoned, I have set forth an improved carrier for cans and the like comprising an apertured sheet or web of resilient stretchable plastic material wherein cans or the like are inserted through the apertures in the sheet. The cans are of greater diameter than the apertures and, accordingly, stretch the apertures and deform the material adjacent the apertures into a frusto-conical shape whereby the cans are aggressively retained against withdrawal in the direction opposite to that in which they have been inserted, but wherein the cans can be pushed all of the way through the sheet or web for relatively easy withdrawal.

This invention represents an improvement over the can carrier device set forth in my aforesaid application, and it is an object of this invention to provide a can-carrier device wherein the cans or other containers are more readily separated from the carrier.

More particularly, it is an object of this invention to provide a container carrier which tenaciously retains cans or other containers, but which is readily severable to release the containers as desired.

Other and further objects and advantages of the present invention will be apparent from the following description when taken in connection with the accompanying drawings wherein:

FIG. 1 is a plan view representing one embodiment of the invention;

FIG. 2 is a plan view of a form of the invention quite similar to that of FIG. 1;

FIG. 3 is a cross sectional view as taken along the line 16-16 of FIG. 1 for example, showing an improved form of handle;

FIG. 4 is a perspective view of the handle of FIG. 3;

FIG. 5 is a graph illustrating the strain pattern in a carrier; and

FIG. 6 is a cross sectional view through a carrier and can identifying areas corresponding to the graph of FIG. 5.

Referring now to the drawings in greater particularity, and first to FIG. 1, there will be seen a carrier designated generally by the numeral 20g and, in many respects, similar to the carrier disclosed in my aforesaid application. More particularly, the carrier comprises a sheet or web of plastic material—polyethylene being a preferred example—having a plurality of apertures 22g therein. The web or sheet may be scalloped in the areas between adjacent apertures 22g in the interests of conserving material. The apertures 22g initially are of somewhat smaller diameter than the cans 26g or the like with which the carrier is to be associated. The sheet or web initially can be flat, or preferably is preformed, to provide frusto-conical sections 27g surrounding the apertures 22g, as in FIG. 6. When a can 26g or the like is inserted through one of the apertures 22g, the material of the web in the vicinity of the aperture is deflected in the direction of the insertion of the can into a frusto-conical shape or into a more pronounced frusto-conical shape in the event that the carrier is performed. As will be observed in FIG. 6, the material of the carrier then engages beneath each can bead while aggressively gripping the body of the can below the bead. The gripping contact of the carrier with the

2

can is circumferentially continuous and is of measurable axial extent.

Accordingly, a can cannot readily be withdrawn in the opposite direction relative to the direction of insertion. However, and as set forth in my prior application identified above, the can is capable of being pushed all of the way through the carrier in the direction of insertion and, in this manner, can be pulled from the carrier without too much difficulty.

In accordance with the present invention, improved means is provided for separating the cans or other containers from the carrier. More particularly, as may be seen in FIGS. 1 and 2, the carrier is perforated along lines indicated generally at 30g and 30h. The perforations do not materially weaken the device or carrier for ordinary handling.

It is to be noted that the perforations 30g spiral in toward the apertures from outside the frusto-conical sections (or the areas to be deformed into such sections) into such sections. Thus, three tabs 72 are provided between adjacent pairs of apertures, the tabs joining the main portion of the carrier at sharp acute angles as indicated at 74. These acute angles provide the outside starting points for the perforations 30g outside the frusto-conical sections; the perforations end at 76 within such sections. It will be apparent that once a tear has been started into a stressed area, as by pulling or twisting one of the tabs 72 (the perforated line 30g on either side of the tab can be torn to the exclusion of the other by properly pulling or twisting the tab), the tear will continue practically automatically through the area of heaviest stress.

As will be seen with reference to FIGS. 5 and 6, the area immediately adjacent the aperture 22g, as indicated at O, is the area of heaviest stress. The stress falls off practically linearly, finally tapering to zero outside the frusto-conical area 27g as indicated at X.

A preferred form of handle 78 is shown in FIGS. 1, 3 and 4. The handle 78 comprises a strap 80 of plastic material having a pair of depending semi-cylindrical legs 82. The legs 82 have cylindrical lower portions 84 with conical tips 86 and reversely oriented barbs 88. The legs project through apertures 90 in the carrier, the conical tips and cylindrical ends stretching the plastic thereof, and the barbs then lock beneath the carrier as shown in FIG. 3.

A variation is shown in FIG. 2, similar numerals again being used, this time with the addition of the suffix h. This form of the invention is similar to that in FIG. 1 except that there is a separate tab 72h for each perforation 30h, each perforation starting at an acute angle junction 74h outside the stressed area, terminating within the stressed area at 76h. For the "six pack" illustrated, there are six tabs and six perforations. As will be seen, two of the tabs are at one end, two at the other, and the remaining two along the opposite sides adjacent the center pair of apertures 22h.

In each form of the invention, the material sections adjacent the apertures are deformed to frusto-conical configuration while gripping a can or other container. The carrier thus aggressively grips each container along a circumferentially continuous line at the margin of each aperture and over a substantial axial distance. The tenacious grip of the carrier on each container thus insures against accidental separation of a container from the carrier. However, the perforations permit the carrier to be torn readily when it is desired to remove a container therefrom. In this connection, it will be noted that the perforations most conveniently are formed in a stamping operation, but could be molded.

The carrier is adapted to retain a variety of containers

3

such as cans, jars, or bottles, and may grip the containers at one end or at both ends.

The specific examples of the invention as herein shown and described are to be understood as being illustrative only. Various changes in structure will no doubt occur to those skilled in the art and will be understood as forming a part of this invention insofar as they fall within the spirit and scope of the appended claims.

I claim:

1. A receptacle for retaining a plurality of containers or the like having annular enlargements at one end in side-by-side substantially abutting and parallel relation; and comprising a substantially unsupported sheet of plastic material, said sheet of plastic material being resilient, deformable, and elastic and having a plurality of apertures therein, each of said apertures having a peripheral measurement less than the periphery of the corresponding container, the material at the edge of each aperture being circumferentially continuous and uninterrupted, the apertures in the sheet being intended for association with the containers whereby such containers can be inserted through said apertures from a given direction when the material adjacent said apertures is stressed and deformed to form circumferentially continuous lips embracing said containers beneath said annular enlargements and resiliently gripping said containers, handle means associated with the sheet for lifting the receptacle, and said sheet of plastic material being provided with a weakened line adjacent each aperture with at least a portion thereof disposed outside of the container-contacting area of the lips when in stretched position with a container inserted there-through, and a tab connected to said portion of each weakened line.

2. A beverage or the like unit comprising a plurality of containers having curvilinear cross sections and annular

4

enlargements, and a sheet of substantially unsupported plastic material having a plurality of curvilinear apertures therein, said sheet of plastic material being resilient, deformable and elastic, the material at the edge of each aperture being circumferentially continuous and uninterrupted, the peripheral measurement of each aperture being less than that of the corresponding containers whereby the containers, inserted axially through said apertures, stretch and deform the material adjacent the apertures into the form of axially directed necks engaging said containers below said enlargements and resiliently gripping the containers to resist withdrawal thereof with the containers depending from the sheet of plastic material in side-by-side abutting relation whereby to reinforce one another upon carrying of the unit, and said sheet of plastic material being provided with a weakened line adjacent each aperture with at least a portion thereof disposed outside of the stretched container-gripping necks, and a tab at the outer extremity of each weakened line.

3. A beverage or the like unit as claimed in claim 2, wherein the weakened lines start outside of the axially directed stretched necks and terminate within the said necks.

References Cited in the file of this patent

UNITED STATES PATENTS

2,302,045	Neumann	Nov. 17, 1942
2,379,934	Seiferth	July 10, 1945
2,418,248	Denton	Apr. 1, 1947
2,874,835	Poupitch	Feb. 24, 1959

FOREIGN PATENTS

220,841	Great Britain	Aug. 28, 1924
848,960	France	May 21, 1952