

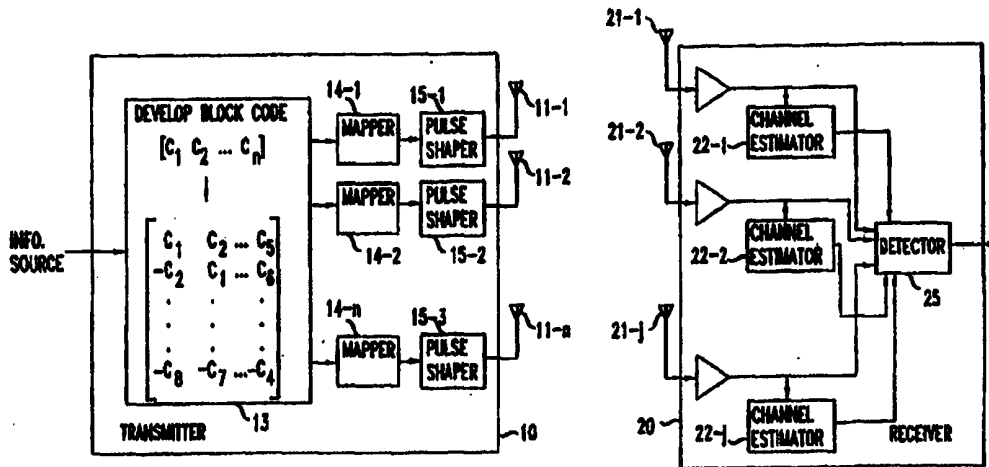

INTERNATIONAL APPLICATION PUBLISHED UNDER THE PATENT COOPERATION TREATY (PCT)

<p>(51) International Patent Classification ⁶ : H04B 7/06, 7/08</p>	<p>A1</p>	<p>(11) International Publication Number: WO 99/45657 (43) International Publication Date: 10 September 1999 (10.09.99)</p>
<p>(21) International Application Number: PCT/US99/04187 (22) International Filing Date: 26 February 1999 (26.02.99) (30) Priority Data: 60/076,613 3 March 1998 (03.03.98) US 09/186,907 6 November 1998 (06.11.98) US (71) Applicant: AT & T CORP. [US/US]; 32 Avenue of the Americas, New York, NY 10013-2412 (US). (72) Inventors: CALDERBANK, Arthur, R.; 85 Worths Mill Lane, Princeton, NJ 08540 (US). JAFARKHANI, Hamid; 1711 Knollwood Drive, Middletown, NJ 07748 (US). NAGUIB, Ayman, F.; 1701 Springfield Avenue, New Providence, NJ 07974 (US). SESHADRI, Nambirajan; 88 Van Houten Avenue, Chatham, NJ 07928 (US). TAROKH, Vahid; 255 Main Street, Madison, NJ 07940 (US). (74) Agents: DWORETSKY, Samuel, H. et al.; AT & T Corp., P.O. Box 4110, Middletown, NJ 07748 (US).</p>		<p>(81) Designated States: BR, CA, CN, JP, KR, MX, European patent (AT, BE, CH, CY, DE, DK, ES, FI, FR, GB, GR, IE, IT, LU, MC, NL, PT, SE). Published <i>With international search report.</i> <i>Before the expiration of the time limit for amending the claims and to be republished in the event of the receipt of amendments.</i></p>

(54) Title: DECODING OF SPACE-TIME CODED SIGNALS FOR WIRELESS COMMUNICATION



$$R_t = \sum_{i=1}^n \sum_{j=1}^n r_j^* h_{i,j}^* \delta_t(i) \quad (9)$$

$$c_i = \arg \min_c |R_t - c|^2 + (-1 + \sum |h_{i,j}|^2) |c|^2 \quad (10)$$

(57) Abstract

A method is disclosed for receiving and decoding space-time coded signals, received over a plurality of antennas. Also disclosed is a generalized approach for maximum likelihood decoding where a decision rule is formed for all of the transmitting antennas of a transmitter, and a decision is made in favor of the transmitted symbols that minimize the equation (10) where (9), (r_j) is the signal received at time interval t , at receiving antenna j , $h_{i,j}^*$ is the complex conjugate of the channel transfer function between the transmitter antenna that is transmitting symbol (c_i) and receiving antenna j , and $\delta_t(i)$ is the sign of symbol c_i in the time interval t .

FOR THE PURPOSES OF INFORMATION ONLY

Codes used to identify States party to the PCT on the front pages of pamphlets publishing international applications under the PCT.

AL	Albania	ES	Spain	LS	Lesotho	SI	Slovenia
AM	Armenia	FI	Finland	LT	Lithuania	SK	Slovakia
AT	Austria	FR	France	LU	Luxembourg	SN	Senegal
AU	Australia	GA	Gabon	LV	Latvia	SZ	Swaziland
AZ	Azerbaijan	GB	United Kingdom	MC	Monaco	TD	Chad
BA	Bosnia and Herzegovina	GE	Georgia	MD	Republic of Moldova	TG	Togo
BB	Barbados	GH	Ghana	MG	Madagascar	TJ	Tajikistan
BE	Belgium	GN	Guinea	MK	The former Yugoslav Republic of Macedonia	TM	Turkmenistan
BF	Burkina Faso	GR	Greece	ML	Mali	TR	Turkey
BG	Bulgaria	HU	Hungary	MN	Mongolia	TT	Trinidad and Tobago
BJ	Benin	IE	Ireland	MR	Mauritania	UA	Ukraine
BR	Brazil	IL	Israel	MW	Malawi	UG	Uganda
BY	Belarus	IS	Iceland	MX	Mexico	US	United States of America
CA	Canada	IT	Italy	NE	Niger	UZ	Uzbekistan
CF	Central African Republic	JP	Japan	NL	Netherlands	VN	Viet Nam
CG	Congo	KE	Kenya	NO	Norway	YU	Yugoslavia
CH	Switzerland	KG	Kyrgyzstan	NZ	New Zealand	ZW	Zimbabwe
CI	Côte d'Ivoire	KP	Democratic People's Republic of Korea	PL	Poland		
CM	Cameroon	KR	Republic of Korea	PT	Portugal		
CN	China	KZ	Kazakstan	RO	Romania		
CU	Cuba	LC	Saint Lucia	RU	Russian Federation		
CZ	Czech Republic	LI	Licthenstein	SD	Sudan		
DE	Germany	LK	Sri Lanka	SE	Sweden		
DK	Denmark	LR	Liberia	SG	Singapore		
EE	Estonia						

DECODING OF SPACE-TIME CODED SIGNALS FOR WIRELESS COMMUNICATION

5

Background of the Invention

This invention relates to wireless communication and, more particularly, to techniques for effective wireless communication in the presence of fading and other degradations.

The most effective technique for mitigating multipath fading in a wireless radio channel is to cancel the effect of fading at the transmitter by controlling the transmitter's power. That is, if the channel conditions are known at the transmitter (on one side of the link), then the transmitter can pre-distort the signal to overcome the effect of the channel at the receiver (on the other side). However, there are two fundamental problems with this approach. The first problem is the transmitter's dynamic range. For the transmitter to overcome an x dB fade, it must increase its power by x dB which, in most cases, is not practical because of radiation power limitations, and the size and cost of amplifiers. The second problem is that the transmitter does not have any knowledge of the channel as seen by the receiver (except for time division duplex systems, where the transmitter receives power from a known other transmitter over the same channel). Therefore, if one wants to control a transmitter based on channel characteristics, channel information has to be sent from the receiver to the transmitter, which results in throughput degradation and added complexity to both the transmitter and the receiver.

Other effective techniques are time and frequency diversity. Using time interleaving together with coding can provide diversity improvement. The same holds for frequency hopping and spread spectrum. However, time interleaving results in unnecessarily large delays when the channel is slowly

varying. Equivalently, frequency diversity techniques are ineffective when the coherence bandwidth of the channel is large (small delay spread).

It is well known that in most scattering environments antenna diversity is the most practical and effective technique for reducing the effect of multipath fading. The classical approach to antenna diversity is to use multiple antennas at the receiver and perform combining (or selection) to improve the quality of the received signal.

The major problem with using the receiver diversity approach in current wireless communication systems, such as IS-136 and GSM, is the cost, size and power consumption constraints of the receivers. For obvious reasons, small size, weight and cost are paramount. The addition of multiple antennas and RF chains (or selection and switching circuits) in receivers is presently not be feasible. As a result, diversity techniques have often been applied only to improve the up-link (receiver to base) transmission quality with multiple antennas (and receivers) at the base station. Since a base station often serves thousands of receivers, it is more economical to add equipment to base stations rather than the receivers

Recently, some interesting approaches for transmitter diversity have been suggested. A delay diversity scheme was proposed by A. Wittneben in "Base Station Modulation Diversity for Digital SIMULCAST," Proceeding of the 1991 IEEE Vehicular Technology Conference (VTC 41 st), PP. 848-853, May 1991, and in "A New Bandwidth Efficient Transmit Antenna Modulation Diversity Scheme For Linear Digital Modulation," in Proceeding of the 1993 IEEE International Conference on Communications (IICC '93), PP. 1630-1634, May 1993. The proposal is for a base station to transmit a sequence of symbols through one antenna, and the same sequence of symbols –but delayed – through another antenna.

U.S. patent 5,479,448, issued to Nambirajan Seshadri on December 26, 1995, discloses a similar arrangement where a sequence of codes is transmitted through two antennas. The sequence of codes is routed through a cycling switch that directs each code to the various antennas, in succession. Since copies of the same symbol are transmitted through multiple antennas at

different times, both space and time diversity are achieved. A maximum likelihood sequence estimator (MLSE) or a minimum mean squared error (MMSE) equalizer is then used to resolve multipath distortion and provide diversity gain. See also N. Seshadri, J.H. Winters, "Two Signaling Schemes for Improving the Error Performance of FDD Transmission Systems Using Transmitter Antenna Diversity," *Proceeding of the 1993 IEEE Vehicular Technology Conference (VTC 43rd)*, pp. 508-511, May 1993; and J. H. Winters, "The Diversity Gain of Transmit Diversity in Wireless Systems with Rayleigh Fading," *Proceeding of the 1994 ICC/SUPERCOMM*, New Orleans, Vol. 2, PP. 1121-1125, May 1994.

Still another interesting approach is disclosed by Tarokh, Seshadri, Calderbank and Naguib in U.S. application, serial number 08/847635, filed April 25, 1997 (based on a provisional application filed November 7, 1996), where symbols are encoded according to the antennas through which they are simultaneously transmitted, and are decoded using a maximum likelihood decoder. More specifically, the process at the transmitter handles the information in blocks of M_1 bits, where M_1 is a multiple of M_2 , i.e., $M_1 = k * M_2$. It converts each successive group of M_2 bits into information symbols (generating thereby k information symbols), encodes each sequence of k information symbols into n channel codes (developing thereby a group of n channel codes for each sequence of k information symbols), and applies each code of a group of codes to a different antenna.

Recently, a powerful approach is disclosed by Alamouti et al in US Patent application 09/074,224, filed May 5, 1998, and titled "Transmitter Diversity Technique for Wireless Communication". This disclosure revealed that an arrangement with two transmitter antennas can be realized that provides diversity with bandwidth efficiency, easy decoding at the receiver (merely linear processing), and performance that is the same as the performance of maximum ratio combining arrangements. In this arrangement the constellation has four symbols, and a frame has two time slots during which two bits arrive. Those bit are encoded so that in a first time slot symbol c_1 and c_2 are sent by the first and second antennas,

respectively, and in a second time slot symbols $-c_2^*$ and c_1^* are sent by the first and second antennas, respectively. Accordingly, this can be expressed by an equation of the form $\mathbf{r}=\mathbf{H}\mathbf{c}+\mathbf{n}$, where \mathbf{r} is a vector of signals received in the two time slots, \mathbf{c} is a vector of symbols c_1 and c_2 , \mathbf{n} is a
 5 vector of received noise signals in the two time slots, and \mathbf{H} is an orthogonal matrix that reflects the above-described constellation of symbols.

The good performance of this disclosed approach forms an impetus for finding other systems, with a larger number of transmit antennas, that has equally good performance.

10 Summary

The prior art teachings for encoding signals and transmitting them over a plurality of antennas are advanced by disclosing a method for encoding for any number of transmitting antennas. Also disclosed is a generalized approach for maximum likelihood decoding where a decision
 15 rule is formed for all of the transmitting antennas of a transmitter, and a decision is made in favor of the transmitted symbols the minimize the equation

$$c_i = \arg \min_c |R_i - c|^2 + (-1 + \sum |h_{i,j}|^2) |c|^2$$

where

$$20 \quad R_i = \sum_{t=1}^n \sum_{j=1}^m r_t^j h_{e_t(i)j}^* \delta_t(i)$$

r_t^j is the signal received at time interval t , at receiving antenna j ,

$h_{e_t(i)j}^*$ is the complex conjugate of the channel transfer function

between the transmitter antenna that is transmitting symbol c_i and receiving antenna j , and

25 $\delta_t(i)$ is the sign of symbol c_i in time interval t .

Brief Description of the Drawings

FIG. 1 is a block diagram of a transmitter having n antennas and a receiver having j antenna, where the transmitter and the receiver operate in accordance with the principles disclosed herein;

Detail Description

FIG. 1 presents a block diagram of an arrangement with a transmitter having n transmitter antenna an a receiver with j receiving antenna. When $n=2$, FIG. 1 degenerates to FIG. 1 of the aforementioned 09/074,224 Alamouti et al application. In that application an applied sequence of symbols $c_1, c_2, c_3, c_4, c_5, c_6$ at the input of transmitter 10 results in the following sequence being sent by antennas 11 and 12.

Time:	t	t+T	t+2T	t+3T	t+4T	t+5T	
Antenna 11	c_0	$-c_1^*$	c_2	$-c_3^*$	c_4	$-c_5^*$
Antenna 12	c_1	c_0^*	c_3	c_2^*	c_5	c_4^*

10

The transmission can be expressed by way of the matrix

$$\begin{bmatrix} c_1 & c_2 \\ -c_2^* & c_1^* \end{bmatrix}, \tag{1}$$

where the columns represent antennas, and the rows represent time of transmission. The corresponding received signal (ignoring the noise) is:

Time:	t	t+T	t+2T	t+3T	
Antenna 11	$h_1c_1 + h_2c_2$	$-h_1c_2^* + h_2c_1^*$	$h_1c_3 + h_2c_4$	$-h_1c_4^* + h_2c_3^*$...

15

where h_1 is the channel coefficient from antenna 11 to antenna 21, and h_2 is the channel coefficient from antenna 12 to antenna 21, which can also be in the form

$$\begin{bmatrix} r_1 \\ r_2^* \end{bmatrix} = \begin{bmatrix} h_1 & h_2 \\ h_2^* & -h_1^* \end{bmatrix} \begin{bmatrix} c_1 \\ c_2 \end{bmatrix}, \text{ or } \mathbf{r} = \mathbf{H}\mathbf{c}. \tag{2}$$

20

Extending this to n antennas at the base station and m antennas in the remote units, the signal r_t^j represents the signal received at time t by antenna j , and it is given by

$$r_t^j = \sum_{i=1}^n h_{ij}c_t^i + n_t^j \tag{3}$$

where n_t^j is the noise at time t at receiver antenna j , and it is assumed to be a independent, zero mean, complex, Gaussian random variable. The average energy of the symbols transmitted by each of the n antennas is $1/n$.

Assuming a perfect knowledge of the channel coefficients, h_{ij} , from
 5 transmit antenna i to receive antenna j , the receiver's decision metric is

$$\sum_{t=1}^l \sum_{j=1}^m \left| r_t^j - \sum_{i=1}^n h_{ij} c_t^i \right|^2 \tag{4}$$

Over all codewords $c_1^1 c_1^2 \dots c_1^n c_2^1 c_2^2 \dots c_2^n \dots c_l^1 c_l^2 \dots c_l^n$ and decides in favor of the codeword that minimizes this sum.

10 For a constellation with real symbols, what is desired is a matrix of size n that is orthogonal, with intermediates $\pm c_1, \pm c_2, \dots, \pm c_n$. The existence problem for orthogonal designs is known in the mathematics literature as the Hurwitz-Radon problem, and was completely settled by Radon at the beginning of the 20th century. What has been shown is that an orthogonal
 15 design exists if and only if $n=2, 4$ or 8 .

Indeed, such a matrix can be designed for the FIG. 1 system for $n=2, 4$ or 8 , by employing, for example, the matrices

$$\begin{bmatrix} c_1 & c_2 \\ -c_2 & c_1 \end{bmatrix}, \tag{5}$$

$$\begin{bmatrix} c_1 & c_2 & c_3 & c_4 \\ -c_2 & c_1 & -c_4 & c_3 \\ -c_3 & c_4 & c_1 & -c_2 \\ -c_4 & -c_3 & c_2 & c_1 \end{bmatrix} \tag{6}$$

20 or

$$\begin{bmatrix}
 c_1 & c_2 & c_3 & c_4 & c_5 & c_6 & c_7 & c_8 \\
 -c_2 & c_1 & c_4 & -c_3 & c_6 & -c_5 & -c_8 & c_7 \\
 -c_3 & -c_4 & c_1 & c_2 & c_7 & c_8 & -c_5 & -c_6 \\
 -c_4 & c_3 & -c_2 & c_1 & c_8 & -c_7 & c_6 & -c_5 \\
 -c_5 & -c_6 & -c_7 & -c_8 & c_1 & c_2 & c_3 & c_4 \\
 -c_6 & c_5 & -c_8 & c_7 & -c_2 & c_1 & -c_4 & c_3 \\
 -c_7 & c_8 & c_5 & -c_6 & -c_3 & c_4 & c_1 & -c_2 \\
 -c_8 & -c_7 & c_6 & c_5 & -c_4 & -c_3 & c_2 & c_1
 \end{bmatrix} \quad (7)$$

What that means, for example, is that when a transmitter employs 8 antennas, it accumulates a frame of 8 bits and, with the beginning of the next frame, in the first time interval, the 8 antennas transmit bits

5 $c_1, c_2, c_3, c_4, c_5, c_6, c_7, c_8$ (the first row of symbols). During the second time interval, the 8 antennas transmit bits $-c_2, c_1, c_4, -c_3, c_6, -c_5, -c_8, c_7$ (the second row of symbols), etc.

A perusal of the above matrices reveals that the rows are mere permutations of the first row, with possible different signs. The

10 permutations can be denoted by $\varepsilon_k(p)$ such that $\varepsilon_k(p) = q$ means that in row k , the symbol c_p appears in column

q . The different signs can be expressed by letting the sign of c_i in the k -th row be denoted by $\delta_k(i)$.

It can be shown that minimizing the metric of equation (4) is

15 equivalent to minimizing the following sum

$$\sum_{i=1}^n \left(\left| \sum_{t=1}^l \sum_{j=1}^m r_t^j h_{\varepsilon_t(i),j}^* \delta_t(i) - c_i \right|^2 + (-1 + \sum |h_{i,j}|^2) |c_i|^2 \right) \quad (8)$$

Since the term $\left| \sum_{t=1}^l \sum_{j=1}^m r_t^j h_{\varepsilon_t(i),j}^* \delta_t(i) - c_i \right|^2 + (-1 + \sum |h_{i,j}|^2) |c_i|^2$ only depends on

c_i , on the channel coefficients, and on the permutations and signs of the matrix, it follows that minimizing the outer sum (over the summing index i)

20 amounts to minimizing each of the terms for $1 \leq i \leq n$. Thus, the maximum likelihood detection rule is to form the decision variable

$$R_i = \sum_{j=1}^m r_j^j h_{z_i(i),j}^* \delta_i(i) \quad (9)$$

for all transmitting antennas, $i=1,2,\dots,n$, and decide in favor of c_i is made in favor of symbol c_i from among all constellation symbols if

$$c_i = \arg \min_c |R_i - c|^2 + (-1 + \sum |h_{i,j}|^2) |c|^2. \quad (10)$$

5 This is a very simple decoding strategy that provides diversity.

There are two attractions in providing transmit diversity via orthogonal designs.

- There is no loss in bandwidth, in the sense that orthogonal designs provide the maximum possible transmission rate at full diversity.
- 10 • There is an extremely simple maximum likelihood decoding algorithm which only uses linear combining at the receiver. The simplicity of the algorithm comes from the orthogonality of the columns of the orthogonal design.

The above properties are preserved even if linear processing at the transmitter is allowed. Therefore, in accordance with the principles disclosed herein, the definition of orthogonal arrays is relaxed to allow linear processing at the transmitter. Signals transmitted from different antennas will now be linear combinations of constellation symbols.

The following defines a Hurwitz-Radon family of matrices.

20 **Defintion:** A set of $n \times n$ real matrices $\{B_1, B_2, \dots, B_k\}$ is called a size k Hurwitz-Radon family of matrices if

$$\begin{aligned} B_i^T B_i &= I \\ B_i^T &= -B_i, \quad i = 1, 2, \dots, k \\ B_i B_j &= -B_j B_i, \quad 1 \leq i < j \leq k. \end{aligned} \quad (11)$$

It has been shown by Radon that when $n = 2^a b$, where b is odd and $a=4c+d$ with $0 \leq d < 4$ and $0 \leq c$, then and Hurwitz-Radon family of $n \times n$ matrices contains less than $\rho(n) = 8c + 2^d \leq n$ matrices (the maximum number of member in the family is $\rho(n) - 1$). A Hurwitz-Radon family that contains $n-1$ matrices exists if and only if $n=2,4,$ or 8 .

Definition: Let A be a $p \times q$ matrix with terms a_{ij} , and let B be any arbitrary matrix. The tensor product $A \otimes B$ is given by

$$\begin{bmatrix} a_{11}B & a_{12}B & \cdots & a_{1q}B \\ a_{21}B & a_{22}B & \cdots & a_{2q}B \\ \vdots & \vdots & \ddots & \vdots \\ a_{p1}B & a_{p2}B & \cdots & a_{pq}B \end{bmatrix} \quad (12)$$

Lemma: For any n there exists a Hurwitz-Radon family of matrices of size $\rho(n) - 1$ whose members are integer matrices in the set $\{-1, 0, 1\}$.

Proof: The proof is by explicit construction. Let I_b denote the identity matrix of size b . We first notice that if $n = 2^a b$ with b odd, then since $\rho(n)$ is independent of b ($\rho(n) = 8c + 2^d$) it follows that $\rho(n) = \rho(2^a)$. Moreover, given a family of $2^a \times 2^a$ Hurwitz-Radon integer matrices $\{A_1, A_2, \dots, A_k\}$ of size $s = \rho(2^a) - 1$, the set $\{A_1 \otimes I_b, A_2 \otimes I_b, \dots, A_k \otimes I_b\}$ is a Hurwitz-Radon family of $n \times n$ integer matrices of size $\rho(n) - 1$. In light of this observation, it suffices to prove the lemma for $n = 2^a$. To this end, we may choose a set of Hurwitz-Radon matrices, such as

$$R = \begin{bmatrix} 0 & 1 \\ -1 & 0 \end{bmatrix}, \quad (13)$$

$$P = \begin{bmatrix} 0 & 1 \\ 1 & 0 \end{bmatrix}, \text{ and} \quad (14)$$

$$Q = \begin{bmatrix} 1 & 0 \\ 0 & -1 \end{bmatrix}, \quad (15)$$

and let $n_1 = s^{4s+3}$, $n_2 = s^{4s+4}$, $n_3 = s^{4s+5}$, $n_4 = s^{4s+6}$, and $n_5 = s^{4s+7}$. Then,

$$\begin{aligned} \rho(n_2) &= \rho(n_1) + 1 \\ \rho(n_3) &= \rho(n_1) + 2 \\ \rho(n_4) &= \rho(n_1) + 4 \\ \rho(n_5) &= \rho(n_1) + 8. \end{aligned} \tag{16}$$

One can observe that matrix R is a Hurwitz-Radon integer family of size $\rho(2) - 1$, $\{R \otimes I_2, P \otimes I_2, \dots, Q \otimes I_2\}$ is a Hurwitz-Radon integer family of size $\rho(2^2) - 1$, and

$$(I_2 \otimes R \otimes I_2, I_2 \otimes P \otimes R, Q \otimes Q \otimes R, P \otimes Q \otimes R, R \otimes P \otimes Q, R \otimes P \otimes P, R \otimes Q \otimes I_2)$$

is an integer Hurwitz-Radon family of size $\rho(2^3) - 1$. Extending from the above, one can easily verify that if $\{A_1, A_2, \dots, A_k\}$ is an integer Hurwitz-Radon family of $n \times n$ matrices, then

$$\{R \otimes I_n\} \cup \{Q \otimes A_i, i = 1, 2, \dots, s\} \tag{17}$$

is an integer Hurwitz-Radon family of $s+1$ integer matrices ($2n \times 2n$).

If, in addition, $\{L_1, L_2, \dots, L_m\}$ is an integer Hurwitz-Radon family of $k \times k$ matrices, then

$$\{P \otimes I_k \otimes A_i, i = 1, 2, \dots, s\} \cup \{Q \otimes L_j \otimes I_n, j = 1, 2, \dots, m\} \cup \{R \otimes I_{nk}\} \tag{18}$$

is an integer Hurewitz-Radon family of $s+m+1$ integer matrices ($2nk \times 2nk$).

With a family of integer Hurwitz-Radon matrices with size $\rho(2^3) - 1$ constructed for $n = 2^3$, with entries in the set $\{-1, 0, 1\}$, equation (17) gives the transition from n_1 to n_2 . By using (18) and letting $k = n_1$ and $n=2$, we get the transition from n_1 to n_3 . Similarly, with $k = n_1$ and $n=4$ we get the transition from n_1 to n_3 , and with $k = n_1$ and $n=8$ we get the transition from n_1 to n_5 .

The simple maximum likelihood decoding algorithm described above is achieved because of the orthogonality of columns of the design matrix. Thus, a more generalized definition of orthogonal design may be tolerated. Not only does this create new and simple transmission schemes for any number of transmit antennas, but also generalizes the Hurwitz-Radon theory to non-square matrices.

Definition: A generalized orthogonal design G of size n is a $p \times n$ matrix with entries $0, \pm x_1, \pm x_2, \dots, \pm x_k$ such that $G^T G = D$ is a diagonal matrix with diagonal $D_{ii}, i = 1, 2, \dots, n$ of the form $(l_1^i x_1^2 + l_2^i x_2^2 + \dots + l_k^i x_k^2)$. The coefficients $l_1^i, l_2^i, \dots, l_k^i$, are positive integers. The rate of G is $R = k / p$.

5 **Theorem:** A $p \times n$ generalized orthogonal design E in variables x_1, x_2, \dots, x_k exists if and only if there exists a generalized orthogonal design G in the same variables and of the same size such that

$$G^T G = (x_1^2 + x_2^2 + \dots + x_k^2) I.$$

In view of the above theorem, without loss of generality, one can
 10 assume that any $p \times n$ generalized orthogonal design G in variable x_1, x_2, \dots, x_k satisfies

$$G^T G = (x_1^2 + x_2^2 + \dots + x_k^2) I.$$

The above derivations can be employed for transmitting signals from n antennas using a generalized orthogonal design.

15 Considering a constellation A of size 2^b , a throughput of kb/p can be achieved. At time slot 1, kb bits arrive at the encoder, which selects constellation symbols c_1, c_2, \dots, c_n . The encoder populates the matrix by setting $x_i = c_i$, and at times $t = 1, 2, \dots, p$ the signals $G_{t1}, G_{t2}, \dots, G_{tn}$ are transmitted simultaneously from antennas $1, 2, \dots, n$. That is the transmission
 20 matrix design is

$$G = \begin{bmatrix} G_{11} & G_{12} & \dots & G_{1n} \\ G_{21} & G_{22} & \dots & G_{2n} \\ \vdots & \vdots & \ddots & \vdots \\ G_{p1} & G_{p2} & \dots & G_{pn} \end{bmatrix} \quad (19)$$

Thus, kb bits are sent during each frame of p transmissions. It can be shown that the diversity order is nm . The theory of space-time coding says that for a diversity order of nm , it is possible to transmit b bits per time slot, and this
 25 is the best possible. Therefore, the rate R is defined for this coding scheme is kb/pb , or k/p .

The following presents an approach for constructing high rate linear processing designs with low decoding complexity and full diversity order. It is deemed advantageous to take transmitter memory into account, and that means that given the rate, R , and the number of transmitting antennas, n , it is advantageous to minimize the number of time slots in a frame, p .

Definition: For a given pair (R, n) , $A(R, n)$ is the minimum number p such that there exists a $p \times n$ generalized design with rate at least R . If no such design exists, then $A(R, n) = \infty$.

The value of $A(R, n)$ is the fundamental question of generalized design theory. The most interesting part of this question is the computation of $A(1, n)$ since the generalized designs of full rate are bandwidth efficient. To address the question the following construction is offered.

Construction I: Let $X = (x_1, x_2, \dots, x_p)$ and $n \leq \rho(p)$. In the discussion above, a family of integer $p \times p$ matrices with $\rho(p) - 1$ with members $\{A_1, A_2, \dots, A_{\rho(p)-1}\}$ was constructed (Lemma following equation 12). That is, the members A_i are in the set $\{-1, 0, 1\}$. Let $A_0 = I$ and consider the $p \times n$ matrix G whose j -th column is $A_{j-1} X^T$ for $j = 1, 2, \dots, n$. The Hurwitz-Radon conditions imply that G is a generalized orthogonal design of full rate.

From the above, a number of facts can be ascertained:

- The value $A(1, n)$ is the smaller number p such that $n \leq \rho(p)$.
- The value of $A(1, n)$ is a power of 2 for any $n \geq 2$.
- The value $A(1, n) = \min(2^{4c+d})$ where the minimization is taken over the set $\{c, d | 0 \leq c, 0 \leq d < 4 \text{ and } 8c + 2^d \geq n\}$.
- $A(1, 2) = 2$, $A(1, 3) = A(1, 4) = 4$, and $A(1, n) = 8$ for $5 \leq n \leq 8$.
- Orthogonal designs are delay optical for $n=2, 4$, and 8.
- For any R , $A(R, n) < \infty$.

The above explicitly constructs a Hurwitz-Radon family of matrices of size p with $\rho(p)$ members such that all the matrices in the family have

entries in the set $\{-1,0,1\}$. Having such a family of Hurwitz-Radon matrices of size $p = A(1,n)$, we can apply Construction I to provide a $p \times n$ generalized orthogonal design with full rate.

- 5 This full rate generalized orthogonal design has entries of the form $\pm c_1, \pm c_2, \dots, \pm c_p$. Thus, for a transmitter having $n \leq 8$ transmit antennas the following optimal generalized designs of rate one are:

$$G_3 = \begin{bmatrix} c_1 & c_2 & c_3 \\ -c_2 & c_1 & -c_4 \\ -c_3 & c_4 & c_1 \\ -c_4 & -c_3 & c_2 \end{bmatrix}, \tag{21}$$

$$G_5 = \begin{bmatrix} c_1 & c_2 & c_3 & c_4 & c_5 \\ -c_2 & c_1 & c_4 & -c_3 & c_6 \\ -c_3 & -c_4 & c_1 & c_2 & c_7 \\ -c_4 & c_3 & -c_2 & c_1 & c_8 \\ -c_5 & -c_6 & -c_7 & -c_8 & c_1 \\ -c_6 & c_5 & -c_8 & c_7 & -c_2 \\ -c_7 & c_8 & c_5 & -c_6 & -c_3 \\ -c_8 & -c_7 & c_6 & c_5 & -c_4 \end{bmatrix}, \tag{22}$$

10

$$G_6 = \begin{bmatrix} c_1 & c_2 & c_3 & c_4 & c_5 & c_6 \\ -c_2 & c_1 & c_4 & -c_3 & c_6 & -c_5 \\ -c_3 & -c_4 & c_1 & c_2 & c_7 & c_8 \\ -c_4 & c_3 & -c_2 & c_1 & c_8 & -c_7 \\ -c_5 & -c_6 & -c_7 & -c_8 & c_1 & c_2 \\ -c_6 & c_5 & -c_8 & c_7 & -c_2 & c_1 \\ -c_7 & c_8 & c_5 & -c_6 & -c_3 & c_4 \\ -c_8 & -c_7 & c_6 & c_5 & -c_4 & -c_3 \end{bmatrix}, \text{ and} \tag{23}$$

$$G_7 = \begin{bmatrix} c_1 & c_2 & c_3 & c_4 & c_5 & c_6 & c_7 \\ -c_2 & c_1 & c_4 & -c_3 & c_6 & -c_5 & -c_8 \\ -c_3 & -c_4 & c_1 & c_2 & c_7 & c_8 & -c_5 \\ -c_4 & c_3 & -c_2 & c_1 & c_8 & -c_7 & c_6 \\ -c_5 & -c_6 & -c_7 & -c_8 & c_1 & c_2 & c_3 \\ -c_6 & c_5 & -c_8 & c_7 & -c_2 & c_1 & -c_4 \\ -c_7 & c_8 & c_5 & -c_6 & -c_3 & c_4 & c_1 \\ -c_8 & -c_7 & c_6 & c_5 & -c_4 & -c_3 & c_2 \end{bmatrix} \quad (24)$$

The simple transmit diversity schemes disclosed above are for a real signal constellation. A design for a complex constellation is also possible.

5 A complex orthogonal design of size n that is contemplated here is a unitary matrix whose entries are indeterminates $\pm c_1, \pm c_2, \dots, \pm c_n$, their complex conjugates $\pm c_1^*, \pm c_2^*, \dots, \pm c_n^*$, or these indeterminates multiplied by $\pm i$, where $i = \sqrt{-1}$. Without loss of generality, we may select the first row to be c_1, c_2, \dots, c_n .

10 It can be shown that half rate ($R=0.5$) complex generalized orthogonal designs exist. They can be constructed by creating a design as described above for real symbols, and repeat the rows, except that each symbol is replaced by its complex conjugate. Stated more formally, given that a design needs to be realized for complex symbols, we can replace each
 15 complex variable $c_i = c_i^R + ic_i^I$, where $i = \sqrt{-1}$, by the 2×2 real matrix

$$\begin{bmatrix} c_i^R & c_i^I \\ -c_i^I & c_i^R \end{bmatrix}. \text{ In this way, } c_i^* = \begin{bmatrix} c_i^R & -c_i^I \\ c_i^I & c_i^R \end{bmatrix} \text{ and } ic_i = \begin{bmatrix} -c_i^R & c_i^I \\ -c_i^I & -c_i^R \end{bmatrix}.$$

It is easy to see that a matrix formed in this way is a real orthogonal design.

The following presents half rate codes for transmission using three and four transmit antennas by, of course, an extension to any number of transmitting

20 antennas follows directly from application of the principles disclosed above.

$$G_c^3 = \begin{bmatrix} c_1 & c_2 & c_3 \\ -c_2 & c_1 & -c_4 \\ -c_3 & c_4 & c_1 \\ -c_4 & -c_3 & c_2 \\ c_1^* & c_2^* & c_3^* \\ -c_2^* & c_1^* & -c_4^* \\ -c_3^* & c_4^* & c_1^* \\ -c_4^* & -c_3^* & c_2^* \end{bmatrix}, \tag{25}$$

$$G_c^4 = \begin{bmatrix} c_1 & c_2 & c_3 & c_4 \\ -c_2 & c_1 & -c_4 & c_3 \\ -c_3 & c_4 & c_1 & -c_2 \\ -c_4 & -c_3 & c_2 & c_1 \\ c_1^* & c_2^* & c_3^* & c_4^* \\ -c_2^* & c_1^* & -c_4^* & c_3^* \\ -c_3^* & c_4^* & c_1^* & -c_2^* \\ -c_4^* & -c_3^* & c_2^* & c_1^* \end{bmatrix}. \tag{26}$$

These transmission schemes and their analogs for higher values of n not only give full diversity but give 3 dB extra coding gain over the uncoded, but they lose half of the theoretical bandwidth efficiency.

Some designs are available that provide a rate that is higher than 0.5. The following presents designs for rate 0.75 for $n=3$ and $n=4$.

$$\left[\begin{array}{ccc} c_1 & c_2 & \frac{c_3}{\sqrt{2}} \\ -c_2^* & c_1^* & \frac{c_3}{\sqrt{2}} \\ \frac{c_3^*}{\sqrt{2}} & \frac{c_3^*}{\sqrt{2}} & \frac{(-c_1 - c_1^* + c_2 - c_2^*)}{2} \\ \frac{c_3^*}{\sqrt{2}} & -\frac{c_3^*}{\sqrt{2}} & \frac{(c_2 + c_2^* + c_1 - c_1^*)}{2} \end{array} \right] \text{ and} \tag{27}$$

$$\begin{bmatrix} c_1 & c_2 & \frac{c_3}{\sqrt{2}} & \frac{c_3}{\sqrt{2}} \\ -c_2^* & c_1^* & \frac{c_3}{\sqrt{2}} & \frac{-c_3}{\sqrt{2}} \\ \frac{c_3^*}{\sqrt{2}} & \frac{c_3^*}{\sqrt{2}} & \frac{(-c_1 - c_1^* + c_2 - c_2^*)}{2} & \frac{(-c_2 - c_2^* + c_1 - c_1^*)}{2} \\ \frac{c_3^*}{\sqrt{2}} & \frac{-c_3^*}{\sqrt{2}} & \frac{(c_2 + c_2^* + c_1 - c_1^*)}{2} & \frac{(c_1 + c_1^* + c_2 - c_2^*)}{2} \end{bmatrix} \cdot \quad (28)$$

FIG. 1 depicts an arrangement where a transmitter includes an encoder 13 that is responsive to an applied stream of symbols. The encoder, in most embodiments will include a memory for storing the incoming symbols. Those are processes in accordance with the above disclosure and, illustratively, are applied to n mappers 14. The mappers map the symbols onto a two dimensional constellation, for example, and apply the mapped symbols to n pulse shapers 15 which modulate the signals and apply them to transmitting antennas 11. The structure of transmitter 10 is illustrative only, and many other designs can be employed that would still realize the benefits of this invention.

The transmitted signals are received by receiver 20, which includes j receiving antennas 21. The received signals are applied to detector 25, which detect signals in accordance with, for example, the detection scheme described above in connection with equations 9 and 10. Channel estimators 22 are conventional. Their function is to estimate the channel parameters for detector 25.

We claim:

1. A receiver for decoding signals sent by a transmitter comprising:
 j receiving antennas; and
 5 a decoder, responsive to said j receiving antennas, for those choosing signals from a known set of signals as the signals sent by the transmitter that minimize

$$c_i = \arg \min_c |R_i - c|^2 + (-1 + \sum |h_{i,j}|^2) |c|^2$$

where

10
$$R_i = \sum_{t=1}^n \sum_{j=1}^m r_t^j h_{\varepsilon_t(i)j}^* \delta_t(i)$$

r_t^j is the signal received at time interval t , at receiving antenna j ,

$h_{\varepsilon_t(i)j}^*$ is the complex conjugate of the channel transfer function

between the transmitter antenna that is transmitting symbol c_i and receiving antenna j , and

- 15 $\delta_t(i)$ is the sign of symbol c_i in time interval t .

2. A receiver for decoding signals sent by a transmitter comprising:
 j receiving antennas; and
 a decoder that employs a maximum likelihood detection rule by

- 20 forming $R_i = \sum_{t=1}^n \sum_{j=1}^m r_t^j h_{\varepsilon_t(i)j}^* \delta_t(i)$ for all transmitting antennas of the transmitter, and deciding in favor of symbol c_i from among all constellation symbols if $c_i = \arg \min_c |R_i - c|^2 + (-1 + \sum |h_{i,j}|^2) |c|^2$

is satisfied, where r_t^j is the signal received at time interval t , at receiving antenna j ,

- 25 $h_{\varepsilon_t(i)j}^*$ is the complex conjugate of the channel transfer function between the transmitter antenna that is transmitting symbol c_i and receiving antenna j , and $\delta_t(i)$ is the sign of symbol c_i in time interval t .

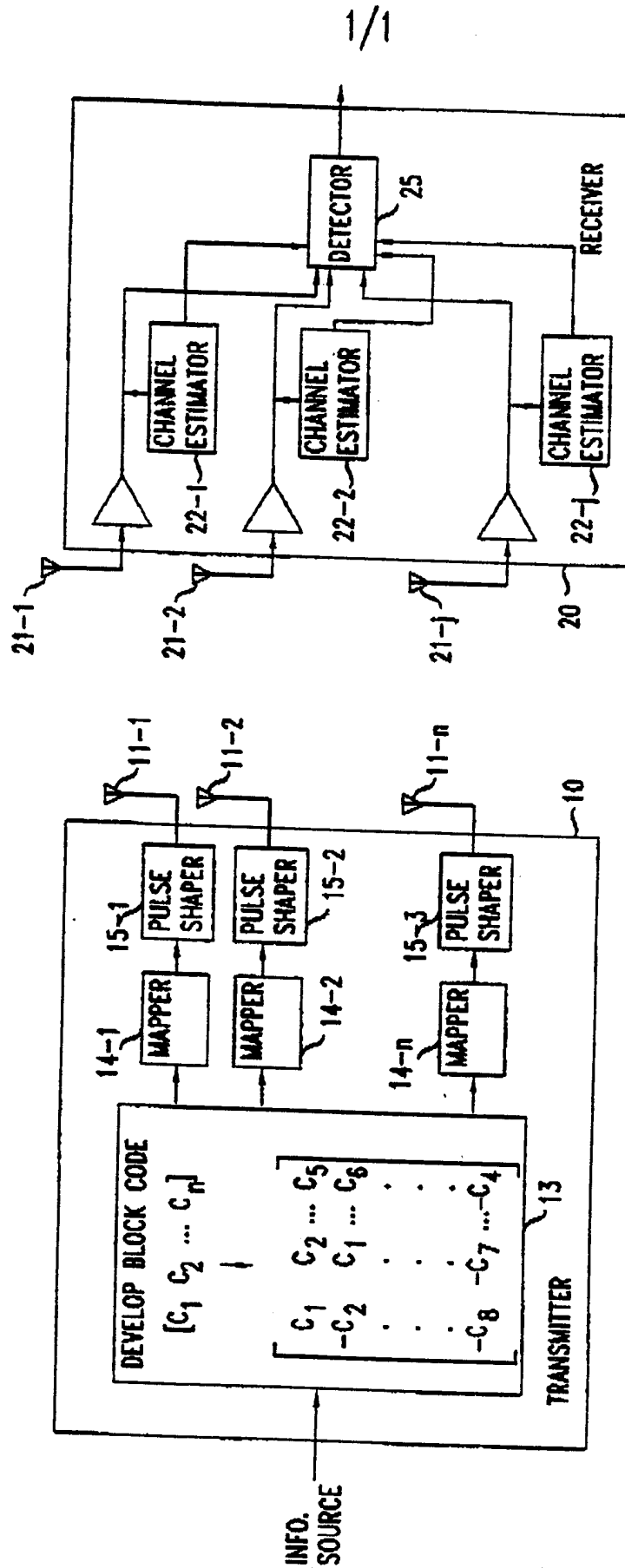

FIG. 1

INTERNATIONAL SEARCH REPORT

International Application No

PCT/US 99/04187

A. CLASSIFICATION OF SUBJECT MATTER
 IPC 6 H04B7/06 H04B7/08

According to International Patent Classification (IPC) or to both national classification and IPC

B. FIELDS SEARCHED

Minimum documentation searched (classification system followed by classification symbols)

IPC 6 H04B

Documentation searched other than minimum documentation to the extent that such documents are included in the fields searched

Electronic data base consulted during the international search (name of data base and, where practical, search terms used)

C. DOCUMENTS CONSIDERED TO BE RELEVANT

Category °	Citation of document, with indication, where appropriate, of the relevant passages	Relevant to claim No.
A	<p>SESHADRI N ET AL: "TWO SIGNALING SCHEMES FOR IMPROVING THE ERROR PERFORMANCE OF FREQUENCY-DIVISION-DUPLEX (FDD) TRANSMISSION SYSTEMS USING TRANSMITTER ANTENNA DIVERSITY" PERSONAL COMMUNICATION - FREEDOM THROUGH WIRELESS TECHNOLOGY, SECAUCUS, NJ., MAY 18 - 20, 1993, no. CONF. 43, 18 May 1993, pages 508-511, XP000393232 INSTITUTE OF ELECTRICAL AND ELECTRONICS ENGINEERS cited in the application see page 510, left-hand column, line 15 - line 42</p> <p style="text-align: center;">---</p> <p style="text-align: center;">-/--</p>	1,2

Further documents are listed in the continuation of box C.

Patent family members are listed in annex.

° Special categories of cited documents :

- "A" document defining the general state of the art which is not considered to be of particular relevance
- "E" earlier document but published on or after the international filing date
- "L" document which may throw doubts on priority claim(s) or which is cited to establish the publication date of another citation or other special reason (as specified)
- "O" document referring to an oral disclosure, use, exhibition or other means
- "P" document published prior to the international filing date but later than the priority date claimed

- "T" later document published after the international filing date or priority date and not in conflict with the application but cited to understand the principle or theory underlying the invention
- "X" document of particular relevance; the claimed invention cannot be considered novel or cannot be considered to involve an inventive step when the document is taken alone
- "Y" document of particular relevance; the claimed invention cannot be considered to involve an inventive step when the document is combined with one or more other such documents, such combination being obvious to a person skilled in the art.
- "&" document member of the same patent family

Date of the actual completion of the international search

23 June 1999

Date of mailing of the international search report

09/07/1999

Name and mailing address of the ISA

European Patent Office, P.B. 5818 Patentlaan 2
 NL - 2280 HV Rijswijk
 Tel. (+31-70) 340-2040, Tx. 31 651 epo nl,
 Fax: (+31-70) 340-3016

Authorized officer

Schut, G

INTERNATIONAL SEARCH REPORT

International Application No

PCT/US 99/04187

C.(Continuation) DOCUMENTS CONSIDERED TO BE RELEVANT

Category	Citation of document, with indication, where appropriate, of the relevant passages	Relevant to claim No.
E	WO 99 14871 A (AT & T WIRELESS SERVICES INC) 25 March 1999 cited in the application see the whole document -----	1

INTERNATIONAL SEARCH REPORT

Information on patent family members

International Application No

PCT/US 99/04187

Patent document cited in search report	Publication date	Patent family member(s)	Publication date
WO 9914871 A	25-03-1999	NONE	