



US00D959729S

(12) **United States Design Patent**
Zhao et al.

(10) **Patent No.:** **US D959,729 S**

(45) **Date of Patent:** **** Aug. 2, 2022**

(54) **LENS FOR FLASHLIGHTS**
(71) Applicant: **Technomate Manufactory Limited,**
Kowloon (HK)

5,227,263 A 7/1993 Blier
D381,347 S * 7/1997 Miyahara D16/134
5,667,293 A 9/1997 Own
5,931,562 A 8/1999 Arato

(Continued)

(72) Inventors: **Hebing Zhao,** Kowloon (HK);
Guosheng Liu, Kowloon (HK)

FOREIGN PATENT DOCUMENTS

(73) Assignee: **TECHNOMATE MANUFACTORY LIMITED,** Hong Kong (CN)

EP 2314912 4/2011
KR 3020010005812 * 6/2002

(Continued)

(**) Term: **15 Years**

OTHER PUBLICATIONS

(21) Appl. No.: **29/685,728**

(22) Filed: **Mar. 29, 2019**

(51) **LOC (13) Cl.** **26-05**

(52) **U.S. Cl.**
USPC **D26/124; D26/118**

(58) **Field of Classification Search**
USPC D26/24, 37-52, 113, 118-120, 124;
D16/217-219, 237

CPC F21Y 2115/10; F21Y 2105/16; F21Y
2105/12; F21Y 2113/10; F21Y 2115/00;
F21Y 2115/15; F21Y 2115/30; F21V
5/007; F21V 5/04; F21V 5/045; F21V
17/101; F21V 5/046; F21V 7/0091; F21V
13/04; F21V 19/002; F21V 23/003; F21V
7/05; F21V 14/06; F21V 15/01; F21V
17/002; F21V 17/005; F21V 17/10; F21V
21/03; F21V 21/26; F21V 31/005; F21V
3/049; F21V 5/002; F21V 5/02; F21V
5/048; F21V 7/04; F21V 7/06; F21V
7/08; F21V 7/28

See application file for complete search history.

Customerized Optical Grade PMMA LED Flashlight Lens Plastic Mould. By Made-inChina.com. Dated Apr. 25, 2019. Found online [Sep. 16, 2021]. <https://sumshun.en.made-in-china.com/product/SsEmNGulZXhb/China-Customerized-Optical-Grade-PMMA-LED-Flashlight-Lens-Plastic-Mould.html> (Year: 2019).*

Primary Examiner — Marissa J Cash
Assistant Examiner — William B Melliar
(74) *Attorney, Agent, or Firm* — Garson & Gutierrez, PC

(57) **CLAIM**

The ornamental design for a lens for flashlights, as shown and described.

DESCRIPTION

FIG. 1 is a perspective view of a lens for flashlights, showing our new design;
FIG. 2 is a rear perspective view of the lens of FIG. 1;
FIG. 3 is a front side elevation view of the lens of FIG. 1;
FIG. 4 is a back side elevation of the lens of FIG. 1;
FIG. 5 is a left side elevation view of the lens of FIG. 1;
FIG. 6 is a right side elevation view of the lens of FIG. 1;
FIG. 7 is a top plan view of the lens of FIG. 1;
FIG. 8 is a bottom plan view of the lens of FIG. 1; and,
FIG. 9 is a cross-sectional view of the lens of FIG. 1, taken along line 9-9 as shown in FIG. 3.

1 Claim, 7 Drawing Sheets

(56) **References Cited**

U.S. PATENT DOCUMENTS

1,958,796 A 5/1934 Mercer
4,265,984 A 5/1981 Kaye
D313,084 S * 12/1990 Bramble D26/113
5,174,649 A 12/1992 Alston

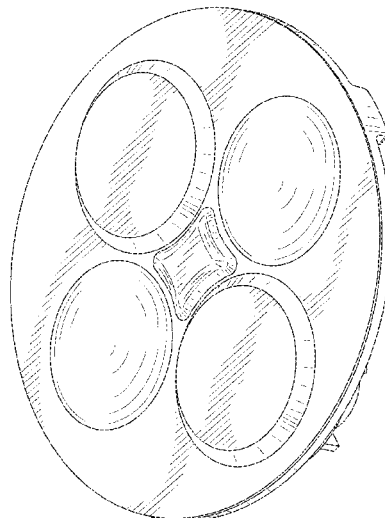

(56)

References Cited

U.S. PATENT DOCUMENTS

5,971,562 A 10/1999 Yang
 6,046,572 A 4/2000 Matthews et al.
 6,238,818 B1 5/2001 Dalton
 6,303,248 B1 10/2001 Peterson
 6,394,622 B1 5/2002 Macek
 6,443,594 B1 9/2002 Marshall
 6,485,160 B1 12/2002 Sommers
 6,773,139 B2 8/2004 Sommers
 6,802,622 B2* 10/2004 Hsien F21L 4/02
 362/187
 6,841,941 B2 1/2005 Kim
 6,851,828 B1 2/2005 Hansen
 7,048,408 B2* 5/2006 Dallas F21V 9/40
 362/202
 7,083,297 B2 8/2006 Matthews
 7,091,694 B1 8/2006 Barton
 D544,117 S * 6/2007 Coushaine D26/37
 D544,618 S * 6/2007 Coushaine D26/37
 7,284,871 B2 10/2007 Oon
 D574,983 S * 8/2008 Rachwal D26/37
 7,438,431 B2 10/2008 Ford
 7,461,944 B2 12/2008 Alessio
 7,509,955 B2 3/2009 Cole
 7,568,816 B2 8/2009 Brass
 7,651,240 B2 1/2010 Bayat
 7,690,815 B2 4/2010 Dallas et al.
 D617,925 S * 6/2010 Coushaine D26/37
 D639,496 S * 6/2011 Wada D26/120
 7,988,318 B1 8/2011 Smith
 8,066,402 B2 11/2011 Klipstein
 8,100,540 B2 1/2012 Huebner
 8,317,357 B2 11/2012 Bayat
 8,388,167 B2 3/2013 Klipstein

8,591,077 B2 11/2013 Okada
 8,801,233 B2 8/2014 Lu
 9,055,670 B2 6/2015 Su et al.
 D745,210 S * 12/2015 Serwacki D26/138
 D757,307 S * 5/2016 Wallach D26/24
 9,534,750 B2 1/2017 Pritchett
 9,562,672 B2 2/2017 Jorgensen
 D781,818 S * 3/2017 Pera D14/209
 9,651,222 B2 5/2017 Jorgensen
 D829,690 S * 10/2018 Chen D14/216
 D831,268 S * 10/2018 Johnson D26/142
 10,096,805 B1 10/2018 Lewis
 D846,418 S * 4/2019 Yang D10/106.8
 D862,779 S * 10/2019 Anderson D26/118
 D870,325 S * 12/2019 Zheng D26/24
 D908,932 S * 1/2021 Richardson D26/24
 10,914,434 B2* 2/2021 Zhao F21V 23/023
 D920,543 S * 5/2021 Wei D26/24
 2003/0147237 A1 8/2003 Halasz
 2003/0189826 A1 10/2003 Yoon
 2004/0130891 A1 7/2004 Twardawski
 2004/0240201 A1 12/2004 Rausseck
 2005/0157492 A1 7/2005 Chiu
 2007/0030673 A1 2/2007 Hull
 2009/0040752 A1 2/2009 Dallas
 2010/0177507 A1 7/2010 West et al.
 2010/0259220 A1 10/2010 Crawford
 2012/0033416 A1 2/2012 Ballard
 2015/0159830 A1 6/2015 Joergensen
 2020/0309330 A1* 10/2020 Zhao H01M 50/213

FOREIGN PATENT DOCUMENTS

KR 3020010005813 * 6/2002
 WO WO201549704 4/2015

* cited by examiner

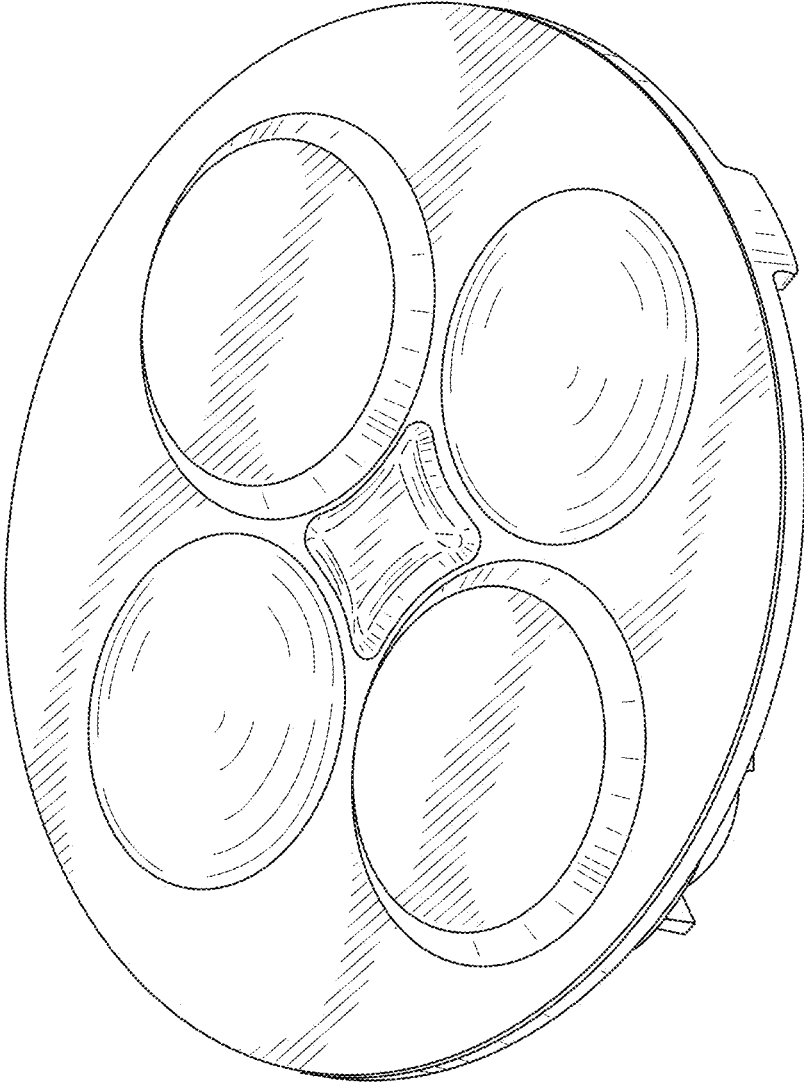

FIG. 1

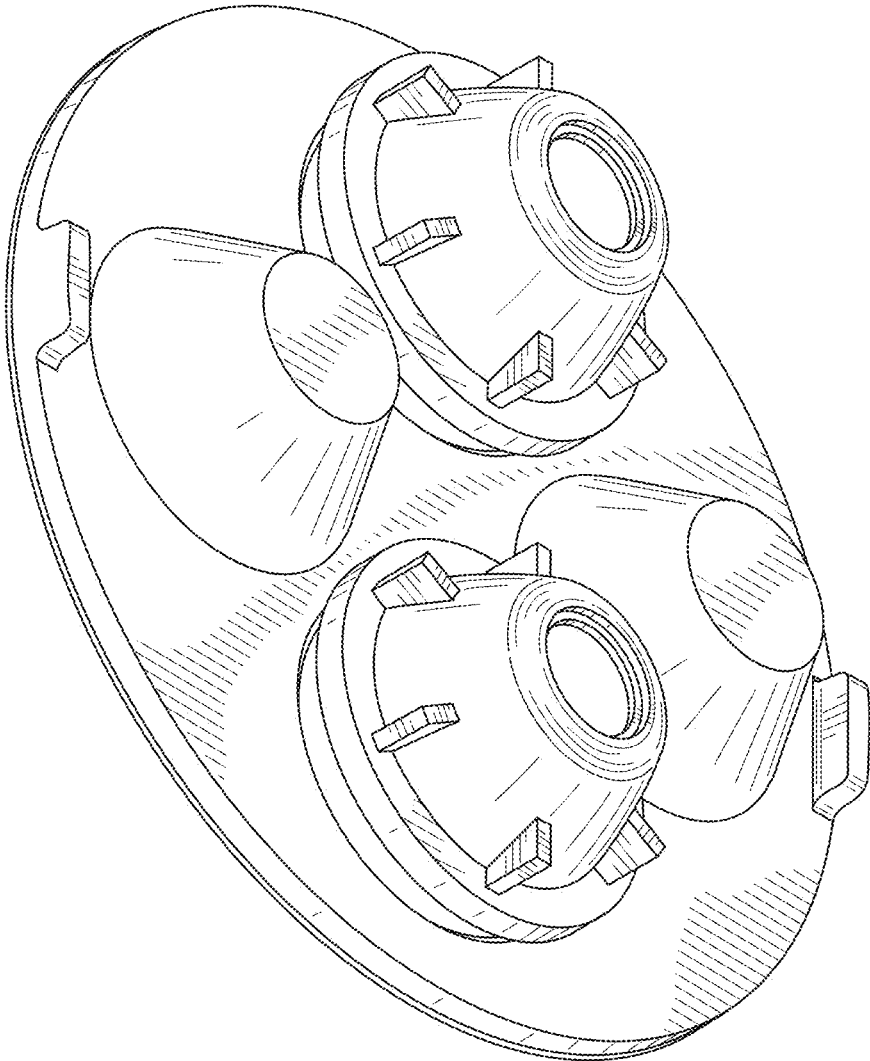
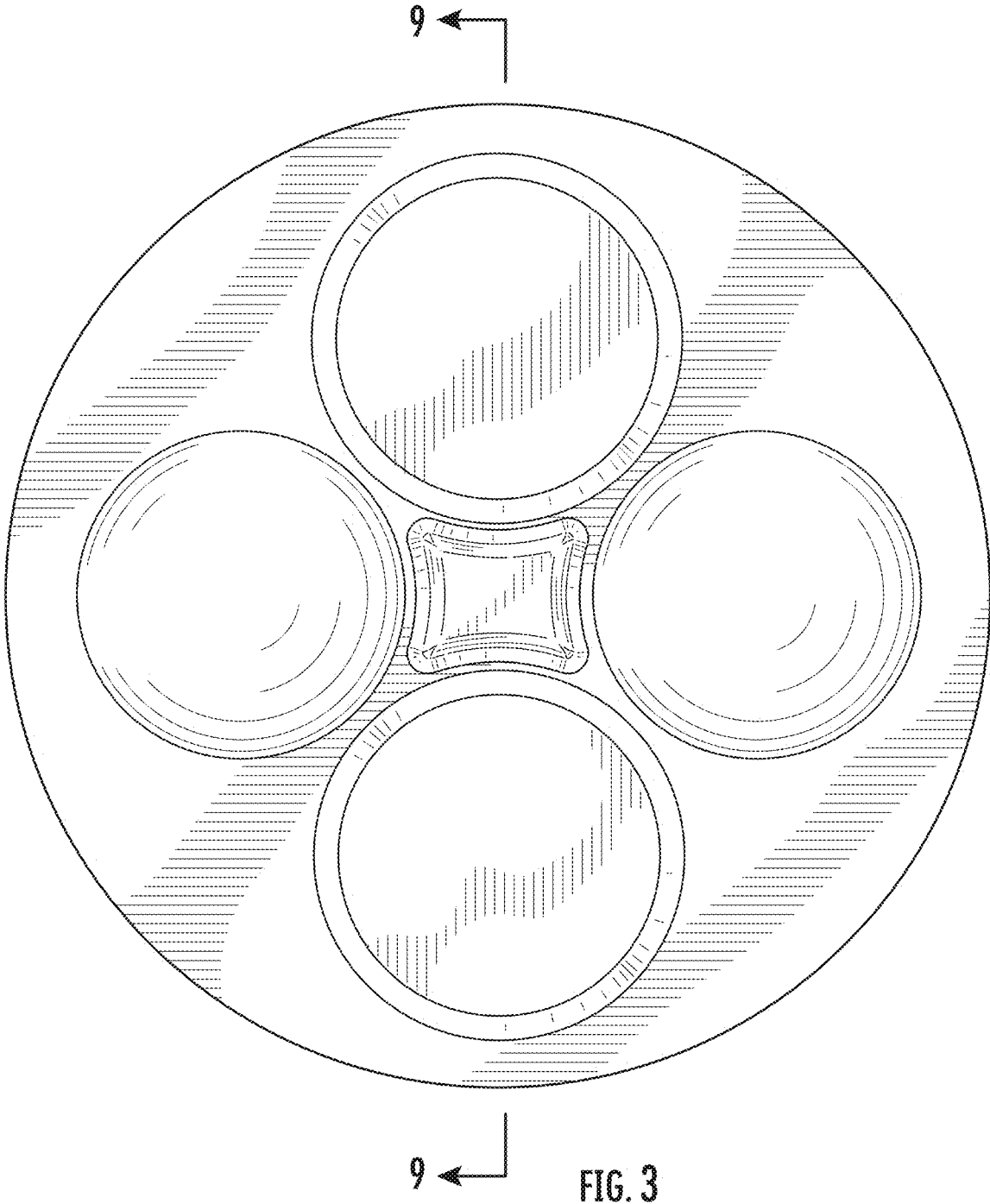

FIG. 2



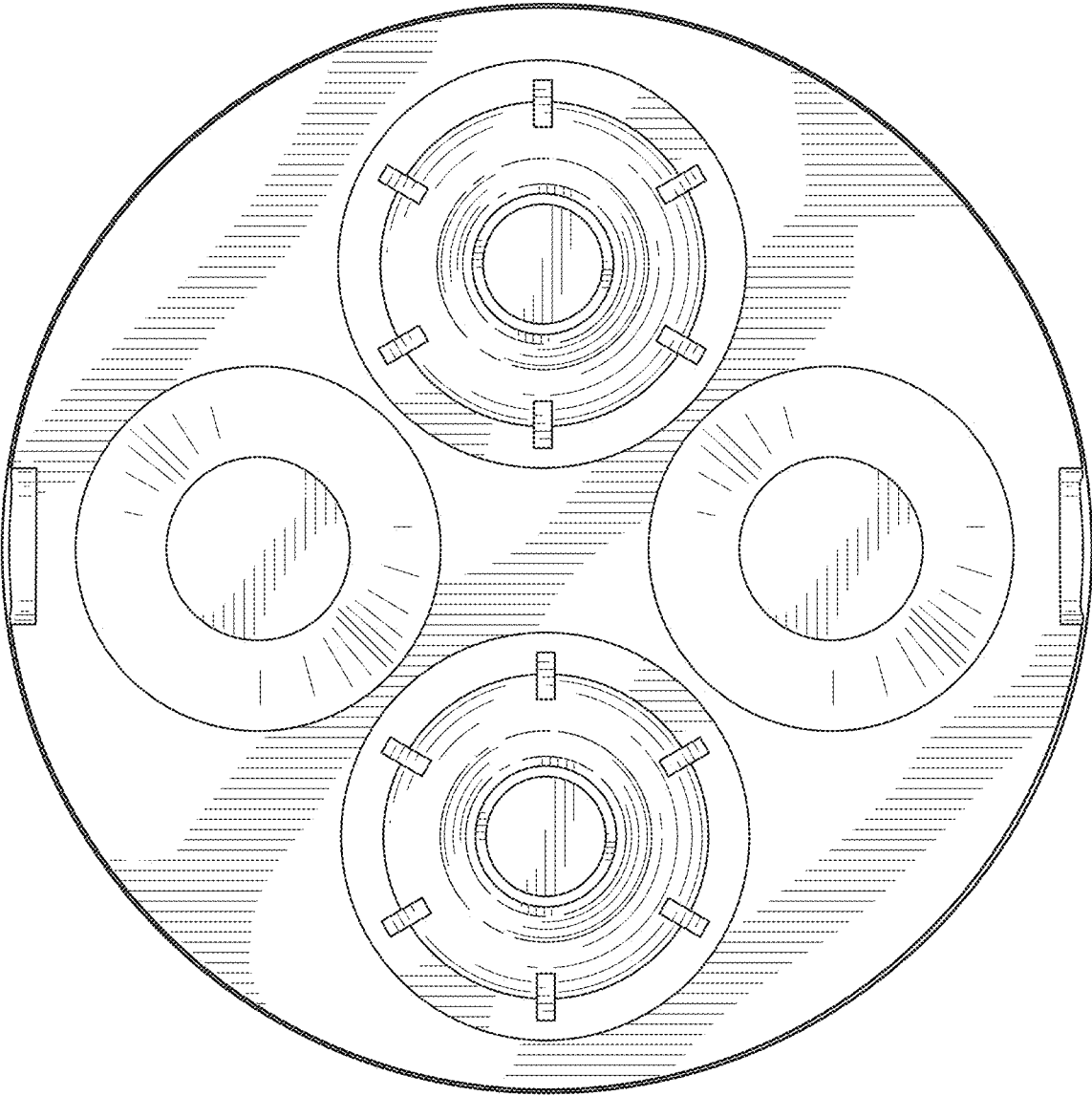

FIG. 4

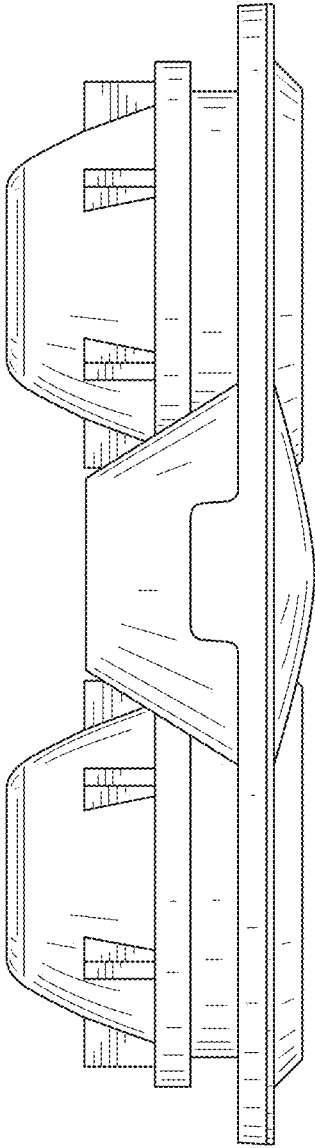

FIG. 5

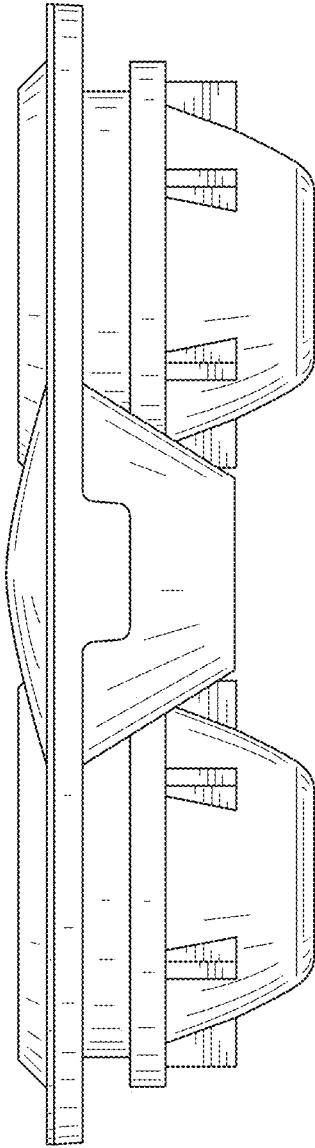

FIG. 6

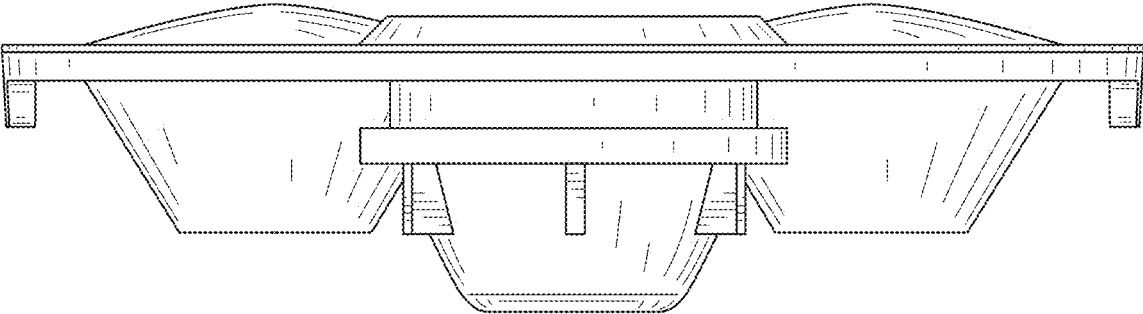

FIG. 7

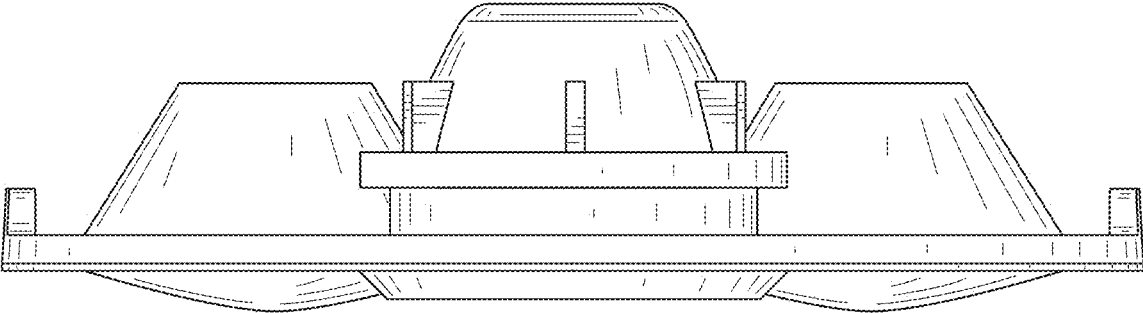

FIG. 8

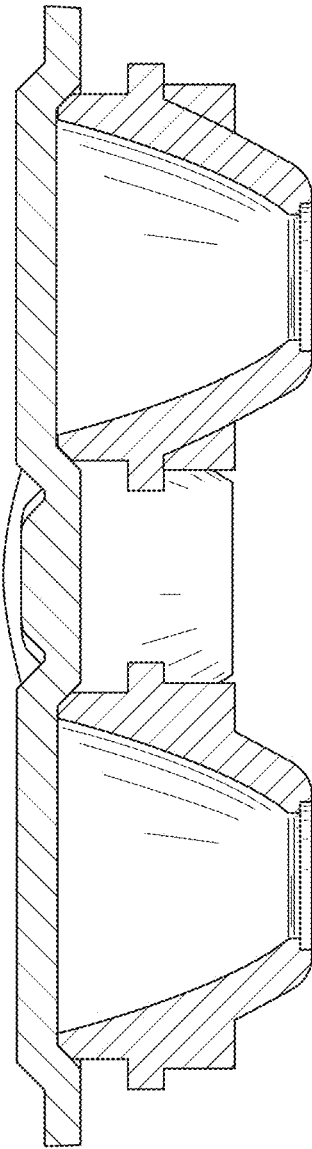

FIG. 9