

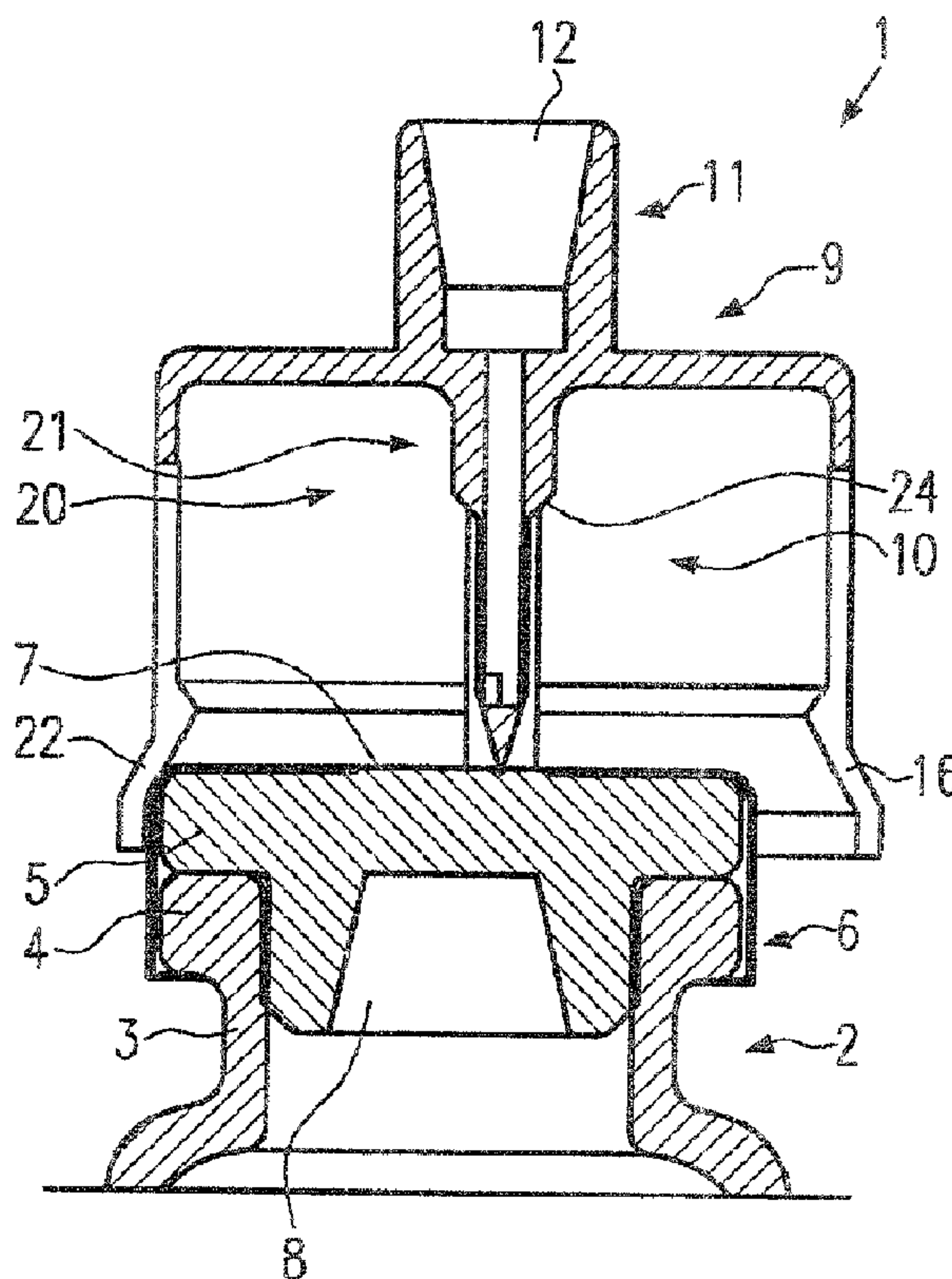

(22) Date de dépôt/Filing Date: 2004/03/04
 (41) Mise à la disp. pub./Open to Public Insp.: 2004/09/05
 (45) Date de délivrance/Issue Date: 2012/06/26
 (30) Priorité/Priority: 2003/03/05 (DE10309796.1)

(51) Cl.Int./Int.Cl. *B65D 51/20* (2006.01),
A61J 1/00 (2006.01), *B65D 81/20* (2006.01)
 (72) Inventeurs/Inventors:
 JANSEN, HUBERT, DE;
 WORTMANN, UWE, DE
 (73) Propriétaire/Owner:
 CSL BEHRING GMBH, DE
 (74) Agent: BERESKIN & PARR LLP/S.E.N.C.R.L.,S.R.L.

(54) Titre : DISPOSITIF DE TRANSFERT
 (54) Title: TRANSFER DEVICE



(57) Abrégé/Abstract:

The invention relates to a transfer device (1), in particular for a container (2) whose interior is under negative pressure and which is closed by means of an elastic stopper (5). The device has a receiving cap (9) and a piercing mandril (10) for piercing the stopper. Relative to its direction of piercing, the piercing mandril is provided with a front piercing portion (20) and with a rear sealing portion (21) which is of greater diameter. In the position in which a bead (4) of the container is inserted into the receiving cap, the sealing portion contacts the stopper. In this way, a tear in the stopper, which tear has been formed by eccentric application of the device onto the container, can be sealed off.



Abstract:

The invention relates to a transfer device (1), in particular for a container (2) whose interior is under negative pressure and which is closed by means of an elastic stopper (5). The device has a receiving cap (9) and a piercing mandril (10) for piercing the stopper. Relative to its direction of piercing, the piercing mandril is provided with a front piercing portion (20) and with a rear sealing portion (21) which is of greater diameter. In the position in which a bead (4) of the container is inserted into the receiving cap, the sealing portion contacts the stopper. In this way, a tear in the stopper, which tear has been formed by eccentric application of the device onto the container, can be sealed off.

(Figure 3)

AVENTIS BEHRING GMBH

2003/M007 (A73)

Transfer device

5 The invention relates to a transfer device, in particular for a container under negative pressure, with a receiving cap for receiving a bead of the container closed by means of an elastic stopper, the receiving cap having an edge portion for centering the
10 bead in its position of insertion in the receiving cap, and a lid portion, and with a central piercing mandril which is connected to the lid portion and projects into the space enclosed by the receiving cap, the piercing mandril piercing the stopper when the bead is inserted
15 into the receiving cap, and the piercing mandril having a flow channel extending through it for a fluid which is conveyed outward through the lid portion.

A transfer device of this kind is known from, for example, US 2002 / 00 87 141 A1. In the latter, the
20 piercing mandril has a constant external diameter, except for its pointed end.

Particularly in transfer devices in which a fluid is to
25 be conveyed into the container under negative pressure, for example in order to dissolve a medical substance with the aid of a medical fluid, it is important that the piercing mandril pushed into the elastic stopper is sealed with respect to the stopper. Only in this way
30 can the negative pressure in the container be maintained. This is necessary in order to draw the fluid into the container by suction. In the event of a preliminary pressure compensation in the container, only an inadequate amount of the fluid gets into the
35 container. The mixing ratio is therefore incorrect, and for this reason the content of the container has to be discarded.

The containers used in connection with such transfer devices are generally designed as glass vials.

In such transfer devices, when the container is inserted into the transfer device, the pointed end of the piercing mandril comes into contact with the stopper before the edge portion of the receiving cap contacts the bead of the container and can thus center the bead and consequently the stopper relative to the piercing mandril. With the eccentric positioning of the stopper relative to the tip of the piercing mandril, the insertion movement, and thus the guiding of the bead of the container by means of the edge portion of the receiving cap, has the effect that the piercing mandril inserted eccentrically into the stopper is now moved into its central position. The result of this is a tear in the rubber, which tear reaches from the site of application of the piercing mandril to the center of the stopper. The piercing mandril, which has a constant diameter, is not suitable for sealing this tear. As a consequence of this, the described leakage occurs.

The object of the present invention is to develop a transfer device of the type mentioned at the outset in such a way that, with the stopper pierced, a fluid-tight contact between piercing mandril and stopper is guaranteed even when the piercing mandril has been applied eccentrically to the stopper.

In a transfer device of the type mentioned at the outset, the object is achieved by the fact that, relative to its direction of piercing, the piercing mandril has a front piercing portion and a rear sealing portion which is of greater diameter, and, in the position in which the bead is inserted into the receiving cap, the sealing portion contacts the stopper.

Thus, in addition to the piercing portion which has the function of piercing the stopper, a sealing portion, to the rear in the direction of piercing, is provided which seals off the tear which has formed in the stopper upon eccentric application of the transfer device to the stopper. As a consequence, the piercing mandril pierces the stopper in a sealing manner, so that leakage is prevented.

10 Advantageously, the diameter of the piercing portion is relatively small, it being entirely possible for this to be of needle thickness.

The transfer device is preferably made of plastic, in particular as an injection-molded part. In this connection, it is considered particularly advantageous if the transfer device is of a substantially rotationally symmetrical design. In this configuration and type of production, the edge of the receiving cap can advantageously be designed with an inward projection which engages behind the bead in the position of insertion of the bead in the receiving cap. To precisely center the piercing mandril relative to the stopper, the axial distance between inward projection and sealing portion should be smaller than the axial distance between inward projection and that surface of the stopper facing the lid when the bead is in the position of insertion in the receiving cap.

30 The piercing mandril can be configured in different ways in order to guarantee the sealing, provided for according to the invention, of the tear in the stopper.

In an advantageous embodiment of the piercing mandril, the transition from the piercing portion to the sealing portion of the piercing mandril is stepped, the end face of the sealing portion of the piercing mandril making annular contact with the stopper. Because of the advantageously selected pairing of materials, on the

- 4 -

one hand the design of the transfer device with the
piercing mandril made of plastic, and on the other hand
the elastic stopper, a preferred refinement is one in
which a sealing element is integrated into the end face
5 of the sealing portion. This is, for example, an
elastic component, preferably an O-ring. The sealing
thus takes place between two elastic parts.

The length of the sealing portion is in particular
10 dimensioned such that the sealing portion penetrates
into the stopper when the bead is in its position of
insertion in the receiving cap. The stopper is thus
sealed under a certain pretensioning, with the result
that the tear formed in the stopper is pressed together
15 under the action of the pressure forces of the piercing
mandril on the stopper.

According to another advantageous embodiment, it is
provided that the piercing portion widens conically
20 toward the sealing portion. The tear in the stopper is
thus sealed on account of the conicity of the sealing
portion. In this case, the sealing portion can be a
conical widening which directly adjoins the piercing
portion. The entire piercing mandril is therefore of
25 conical design. It is equally conceivable for the
piercing mandril to have a stepped design in which the
conically widening sealing portion adjoins the step
between piercing portion and sealing portion. The tear
in the stopper is in this case sealed via the conical
30 surface of the sealing portion. In principle, it is
possible for a wider area of the sealing portion to
adjoin the conical sealing portion in a stepped manner.
In this case, the stopper is on the one hand sealed
radially via the conical area of the sealing portion
35 and on the other hand sealed axially by the adjoining
stepped area of the sealing portion.

Further features of the invention are set out in the description of the figures, and in the figures themselves.

5 In the figures in the drawing, the invention is depicted on the basis of a number of illustrative embodiments, without being limited thereto. In the drawing:

10 Fig. 1 shows a perspective view of a first illustrative embodiment of the transfer device according to the invention, seen obliquely from below,

15 Fig. 2 shows a longitudinal central section through the transfer device shown in Figure 1,

Fig. 3 shows, in a longitudinal central section, the transfer device according to Figures 1 and 2 at
20 the moment of its eccentric application to the stopper fitted in a glass vial,

Fig. 4 shows a cross-sectional representation of the arrangement according to Figure 3, with the
25 piercing mandril centered and inserted into the stopper,

Fig. 5 shows a cross-sectional representation of the arrangement according to Figures 3 and 4, with
30 the transfer device applied fully to the glass vial,

Fig. 6 shows a perspective view of a second illustrative embodiment of the transfer device,
35 seen obliquely from below,

Fig. 7 shows the transfer device according to Figure 6, in a longitudinal central section,

Fig. 8 shows a perspective view of a third illustrative embodiment of the transfer device, seen obliquely from below,

5 Fig. 9 shows the transfer device according to Figure 8 in a longitudinal central section.

The transfer device 1 according to the first illustrative embodiment shown in Figures 1 through 5 is produced as an injection-molded plastic part. It is used in particular for a container whose interior is under negative pressure and which is designed as a glass vial 2.

15 Adjacent to its neck 3, the glass vial 2 has a bead 4 into which an elastic stopper 5 is inserted. The external diameter of the stopper 5 corresponds to that of the bead 4. The stopper 5 is held securely in the bead 4 by means of a thin-walled cap 6 which surrounds the stopper 5 and the bead 4, except for a central opening 7 in the cap 6 in the area of the axis of symmetry of cap 6 and glass vial 2. The area of the stopper 5 inserted into the glass vial 2 is of annular design so that, directed toward the interior of the glass vial 2, a recess 8 is formed in the stopper 5. In this area, the stopper 5 has a thickness corresponding to that of the stopper in the area of the outer edge.

The transfer device 1 is formed by a receiving cap 9, a piercing mandril 10 and a connector piece 11. The connector piece 11 is provided with a conically tapering recess 12 which serves to receive, for example, the syringe cone of a disposable syringe. Moreover, the connector piece 11 is suitable for receiving another complementary transfer device in a sealed manner, for example as is described in US 2002/0087,141 A1 in respect of the basic design and use of the transfer device. In this case, the whole device serves for transferring a medical fluid, which is

- 7 -

located in a first glass vial, into a second glass vial, in the present case the glass vial 2, which is under negative pressure and in which, for example, there is a medical substance which is to be dissolved. After this substance has dissolved, the other transfer device is separated from the transfer device 1, and, after the vial 2 has been turned upside down, the disposable syringe inserted into the connector piece 11 can be used to removed the dissolved substance from this vial.

The receiving cap 9 of the transfer device 1 has an edge portion 13 for centering the bead 4 in its position of insertion in the receiving cap 9. The edge portion 13 is provided axially with four tabs 14 which each extend over a sector of 90° and are mounted so as to yield radially with respect to a lid portion 15 adjacent to the edge portions 13 of the receiving cap 9, so that they can spring outward when the glass vial 2 is inserted into the transfer device 1. The edge portion 13 is provided with an inwardly directed projection 16. The latter engages behind the bead 4 of the vial 2 in the bead's position of insertion in the receiving cap 9 (as is illustrated in Figure 5). This inward projection 16 is arranged parallel to the plate-shaped lid portion 15.

In the rotationally symmetrical transfer device 1, the piercing mandril 10 is connected to the lid portion 15. Its end directed away from the lid portion 15 is pointed. A flow channel 17 extending through the piercing mandril 10 is provided with radial openings 18 in the area of the tip of the piercing mandril 10, and it is connected at its other end to the recess 12. The piercing mandril 10 thus projects into the space 19 enclosed by the receiving cap 9.

Relative to its direction of piercing, the piercing mandril 10 has a front piercing portion 20 and a rear

sealing portion 21 which is of greater diameter. The transition from the piercing portion 20 to the sealing portion 21 is stepped. The length of the sealing portion 21 is dimensioned such that it penetrates into the stopper 5 when the bead 4 is in its position of insertion in the receiving cap 9. This is due to the axial distance A between inward projection 16 and sealing portion 21 being smaller than the axial distance B between inward projection 16 and that surface of the stopper 5 facing the lid portion 15, when the bead 4 is in its position of insertion in the receiving cap 9.

The details explained above can be taken from Figures 3 through 5 which illustrate the procedure for inserting the glass vial 2 into the transfer device 1: Figure 3 shows the transfer device 1 applied with the tip of the piercing mandril 10 eccentrically to the stopper 5. At this moment, the geometry of the transfer device 1 means that the inward projection 16 used for centering is not yet in contact with the stopper 5 or the cap 6 surrounding this. Instead, the transfer device 1 lies on the cap 6 via a conically tapering insertion bevel 22 of the edge portion 13 along a short line or a punctiform contact. When the glass vial 2 is inserted farther into the transfer device 1, as is illustrated in Figure 4, the insertion bevel 22 and the inward projection 16 ensure that the glass vial 2 with the stopper 5 is centered with respect to the transfer device 1. Since the axial piercing movement of the piercing mandril 10 is superposed by a radial movement, a tear 23 forms in the elastic stopper 5 during piercing of the stopper 5, which is designed in particular as a rubber stopper. When the glass vial 2 is pushed farther into the transfer device 1 until the inward projection 16 engages behind the cap 6 in the area of the bead 4 of the glass vial, the sealing portion 21 of the piercing mandril 10 is in a position relative to the stopper 5 in which it not only touches

the latter but in which its end face is forced into the stopper 5. The end face 24 of the sealing portion 21 thus contacts the stopper 5 in an annular formation. The stepped formation between sealing portion 21 and piercing portion 20 is chosen such that, when the glass vial 2 is inserted fully into the transfer device 1 as is shown in Figure 5, the tear 23 is sealed off by the sealing portion 21.

10 The embodiment according to Figures 6 and 7 differs from that according to Figures 1 through 5 in that an O-ring 25 is fitted into the end face 24 of the sealing portion 21. In this embodiment, the elastic O-ring 25 thus contacts the elastic stopper 5, in contrast to the
15 embodiment according to Figures 1 through 5 in which the elastic stopper 5 is contacted by the nonelastic sealing portion 21.

The embodiment according to Figures 8 and 9 differs
20 from that according to Figures 1 through 5 in that the piercing portion 20 widens conically starting from the tip of the piercing mandril 10. Upon insertion of the glass vial 2 into the transfer device 1 in the sense of the functional representation according to Figures 3
25 through 5, a certain sealing effect in the area of the tear 23 is already achieved by means of the conically shaped piercing portion 20 when the piercing mandril 10 penetrates into the stopper 5. When the glass vial 2 is in the position in which it has been inserted fully
30 into the transfer device 1, additional sealing is afforded via the end face 24 of the sealing portion 21.

Alternatively, in the embodiment according to Figures 8 and 9 the dimensions can be such that, in the assembly
35 position according to Figure 5, the portion 21 does not contact the stopper 5, and instead the conically shaped portion 20 performs both the function of the piercing portion and that of the sealing portion. The sealing is thus achieved exclusively as a result of the radial

- 10 -

action of the portion 20 on the stopper 5, specifically the tear 23 in the stopper 5.

List of reference numbers

| | | |
|----|----|-------------------|
| | 1 | transfer device |
| 5 | 2 | glass vial |
| | 3 | neck of vial |
| | 4 | bead |
| | 5 | stopper |
| | 6 | cap |
| 10 | 7 | opening |
| | 8 | recess |
| | 9 | receiving cap |
| | 10 | piercing mandril |
| | 11 | connector piece |
| 15 | 12 | recess |
| | 13 | edge portion |
| | 14 | tab |
| | 15 | lid portion |
| | 16 | inward projection |
| 20 | 17 | flow channel |
| | 18 | opening |
| | 19 | space |
| | 20 | piercing portion |
| | 21 | sealing portion |
| 25 | 22 | insertion bevel |
| | 23 | tear |
| | 24 | end face |
| | 25 | O-ring |

Claims:

1. A transfer device (1), for a container (2) whose interior is under negative
5 pressure, comprising:
- a receiving cap (9) for receiving a bead (4) of the container (2) that is
closed by means of an elastic stopper (5), the receiving cap (9) comprising
10 an edge portion (13) for centering the bead (4) in its position of insertion in
the receiving cap (9), and
- a lid portion (15), and with a central piercing mandril (10) which is
connected to the lid portion (15) and which projects into a space (19)
15 enclosed by the receiving cap (9), the piercing mandril (10) piercing the
stopper (5) when the bead (4) is inserted into the receiving cap (9), and
the piercing mandril (10) having a flow channel (17) extending
therethrough for a fluid which is conveyed outward through the lid portion
(15),
20
- wherein the piercing mandril (10) has a front piercing portion (20) and a
rear sealing portion (21), the rear sealing portion is of greater diameter
than a diameter of the front piercing portion
- 25 wherein the length of the sealing portion (21) is dimensioned such that the
sealing portion (21) penetrates into the stopper (5) when the bead (4) is in
its position of insertion in the receiving cap (9), and
- 30 wherein the piercing portion (20) widens conically towards the sealing
portion (21) at a first angle and the sealing portion (21) widens conically
towards the lid portion (15) at a greater angle than the first angle.
2. The device as claimed in claim 1, wherein said device is of a rotationally
symmetrical design.

3. The device as claimed in any one of claims 1 through 2, wherein the edge portion (13) of the receiving cap (9) has an inward projection (16) for engaging behind the bead (4) when the bead (4) is in its position of insertion in the receiving cap (9).
- 5
4. The device as claimed in claim 1, wherein the sealing element (25) is designed as an O-ring.
5. The device as claimed in claim 1, wherein the sealing portion (21) adjoins the piercing portion (20) in a stepless configuration.
- 10
6. A transfer device (1), for a container (2) whose interior is under negative pressure, comprising
- a receiving cap (9) for receiving a bead (4) of the container (2) that is closed by means of an elastic stopper (5), the receiving cap (9) comprising
- 15 an edge portion (13) for centering the bead (4) in its position of insertion in the receiving cap (9), and
- a lid portion (15), and with a central piercing mandril (10) which is connected to the lid portion (15) and which projects into a space (19) enclosed by the receiving cap (9), the piercing mandril (10) piercing the stopper (5) when the bead (4) is inserted into the receiving cap (9), and
- 20 the piercing mandril (10) having a flow channel (17) extending therethrough for a fluid which is conveyed outward through the lid portion (15),
- wherein the piercing mandril (10) has a front piercing portion (20) and a rear sealing portion (21), the rear sealing portion is of greater diameter than a diameter of the front piercing portion
- 25 wherein the length of the sealing portion (21) is dimensioned such that the sealing portion (21) penetrates into the stopper (5) when the bead (4) is in its position of insertion in the receiving cap (9) and

wherein the sealing portion (21) adjoins the piercing portion (20) and widens conically rearwardly towards the lid portion (15).

- 5 7. The device as claimed in claim 6, wherein said device is of a rotationally symmetrical design.
- 10 8. The device as claimed in any one of claims 6 through 7, wherein the edge portion (13) of the receiving cap (9) has an inward projection (16) for engaging behind the bead (4) when the bead (4) is in its position of insertion in the receiving cap (9).
9. The device as claimed in claim 6, wherein the sealing element (25) is designed as an O-ring.
10. The device as claimed in claim 6, wherein the sealing portion (21) adjoins the piercing portion (20) in a stepless configuration.
- 15 11. The device as claimed in any one of claims 1 and 6, wherein the piercing portion (20) includes a piercing tip and linear portion that extends between the piercing tip and the sealing portion (21) wherein the sealing portion (21) widens conically rearwardly from the linear portion towards the lid portion (15).

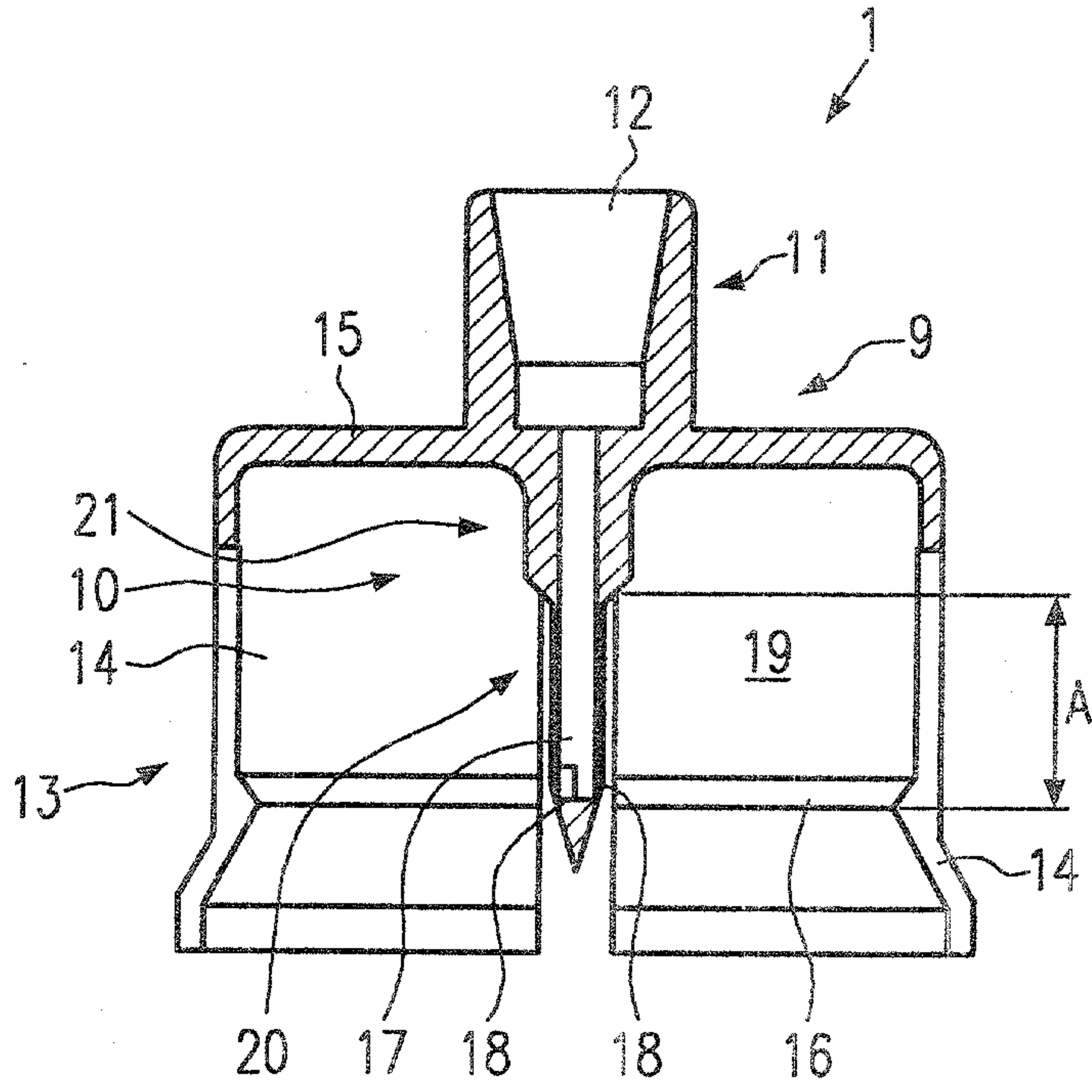

Fig.2

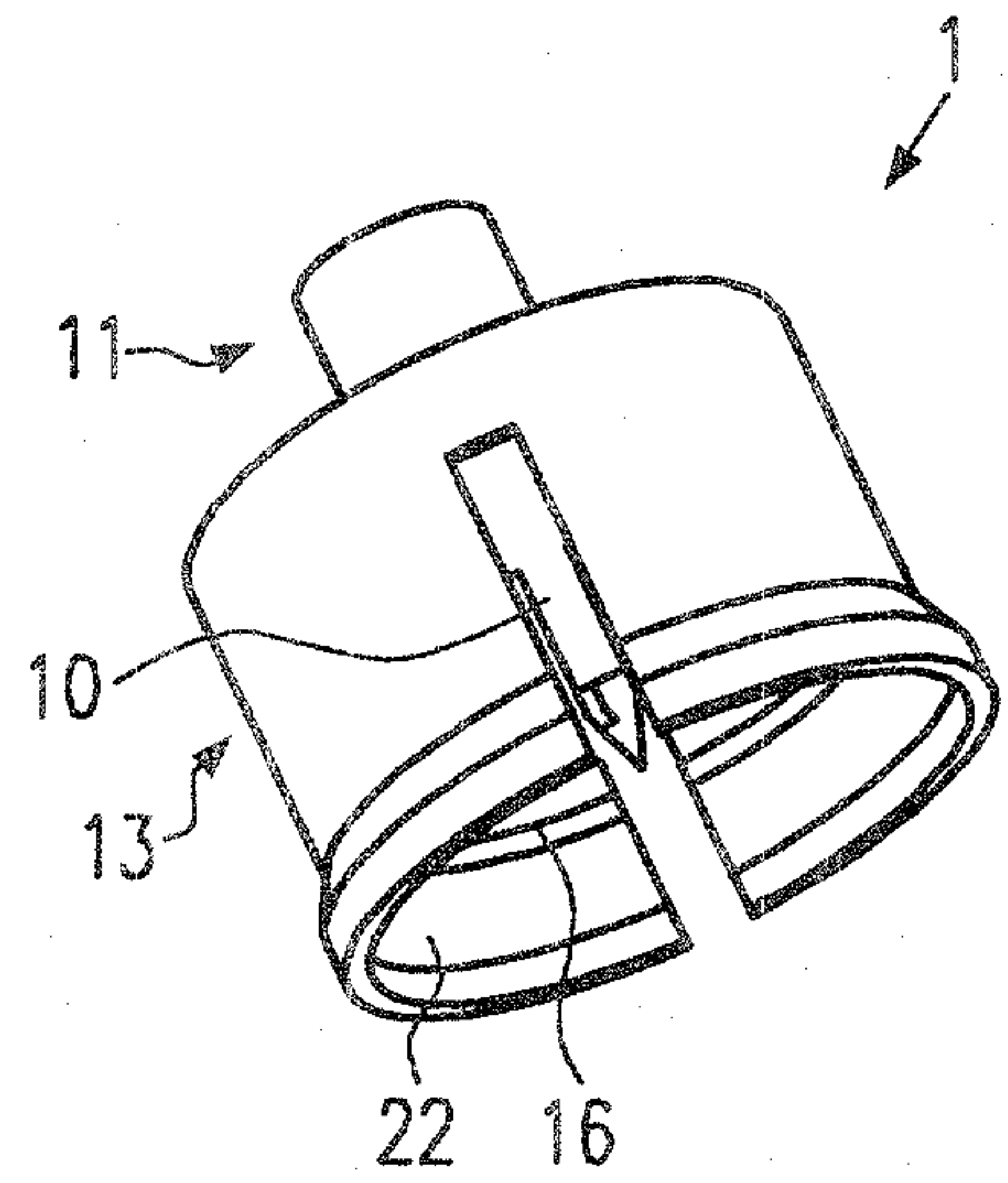

Fig.1

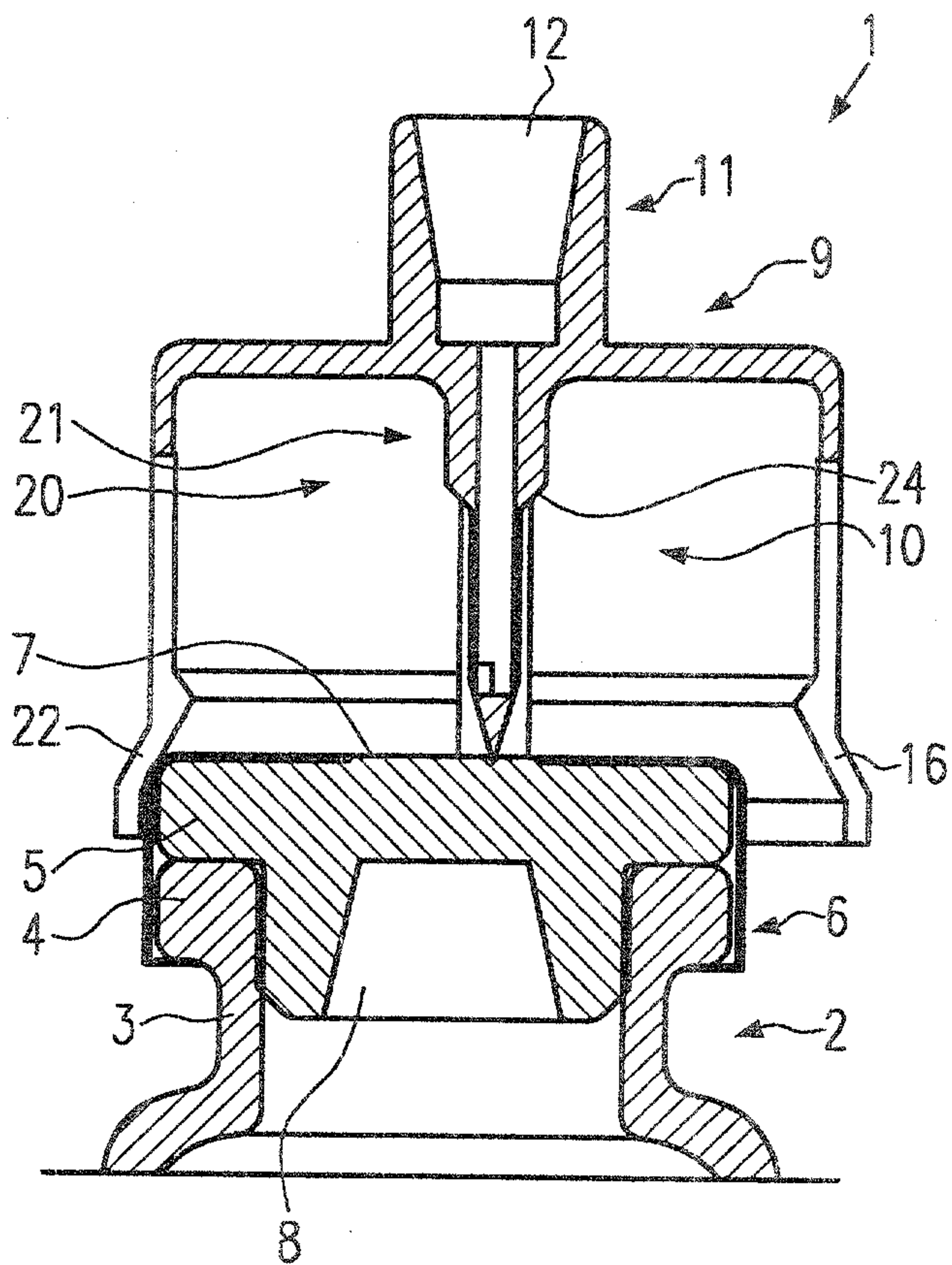

Fig.3

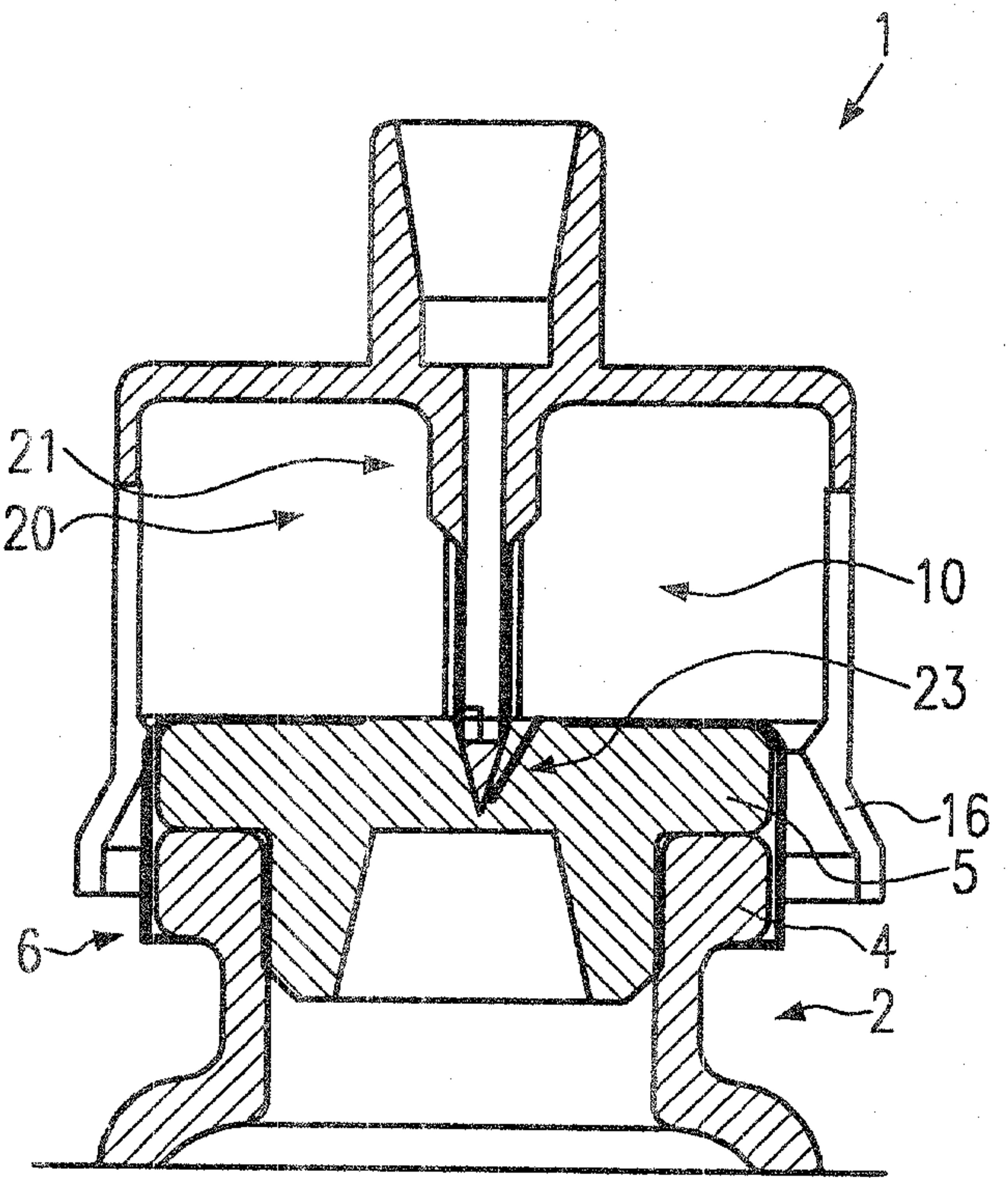

Fig.4

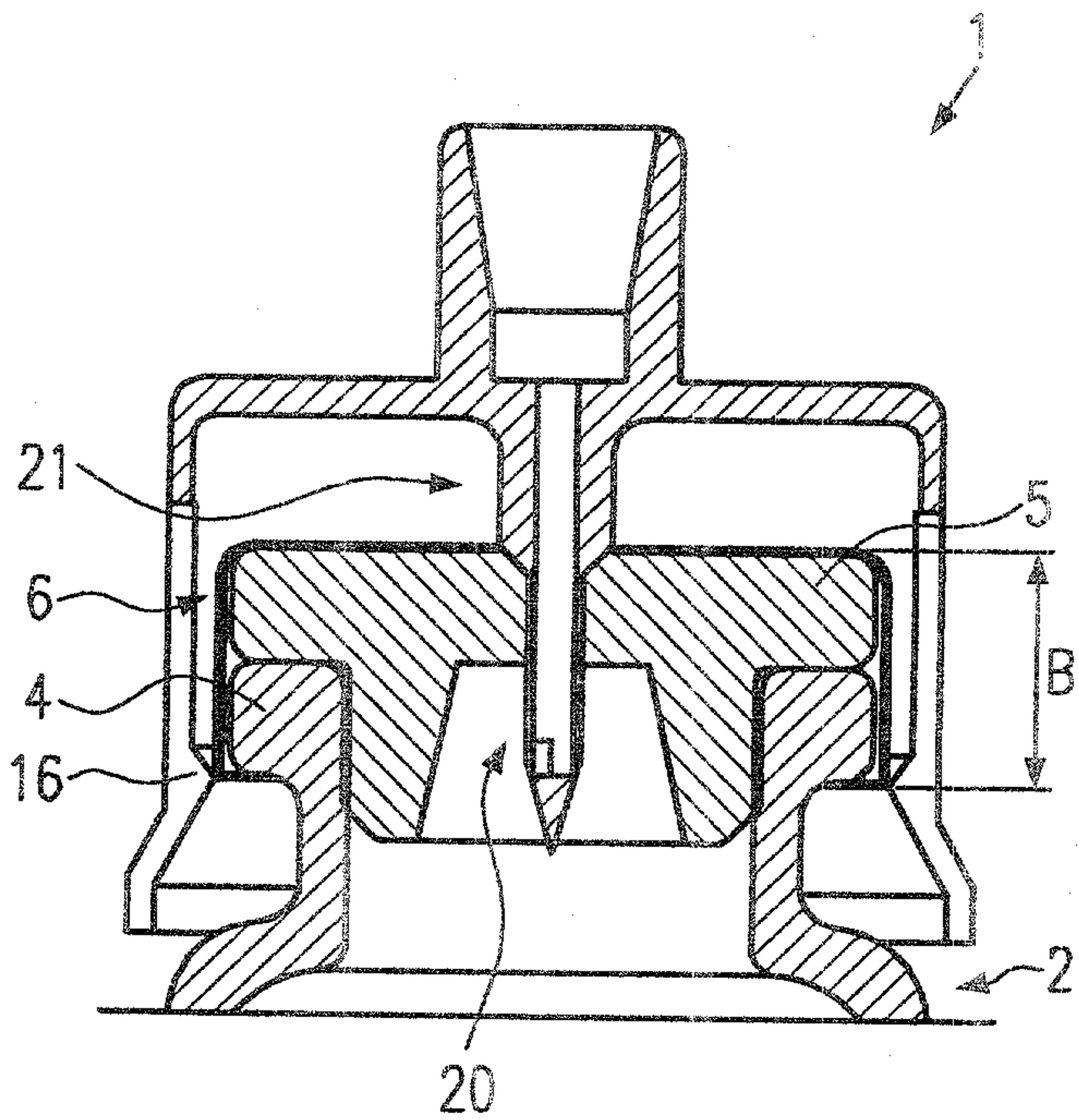

Fig.5

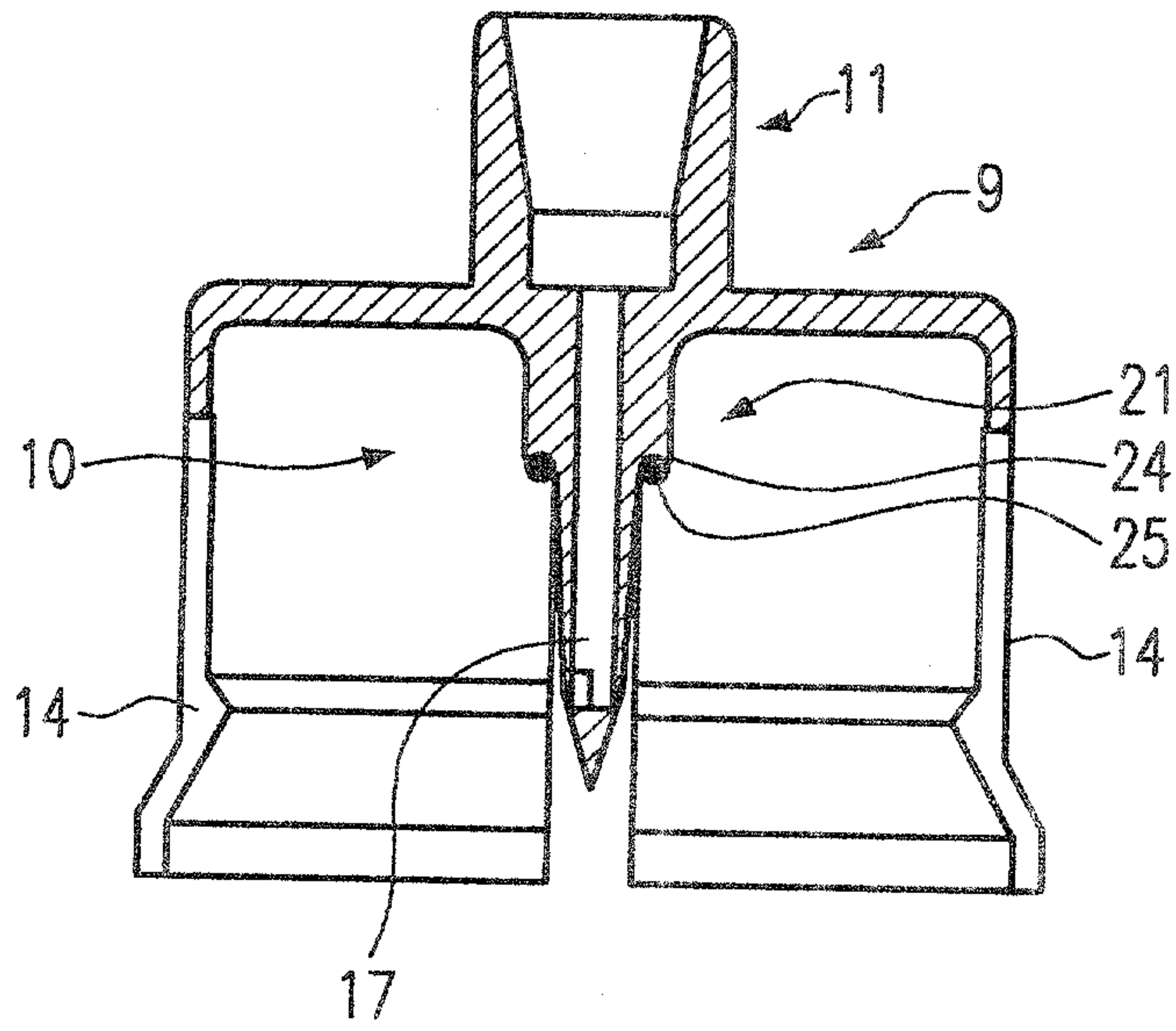

Fig. 7

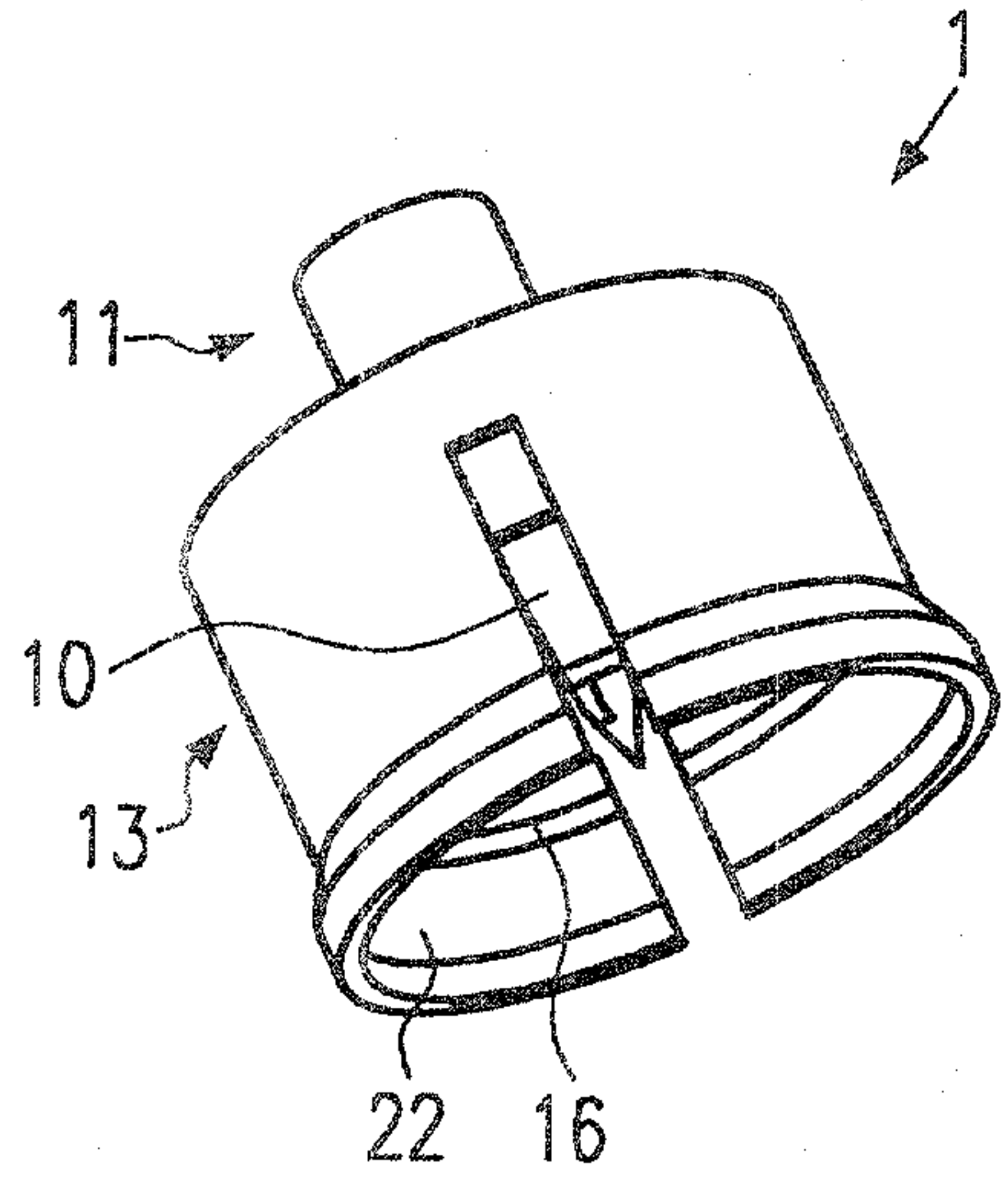

Fig. 6

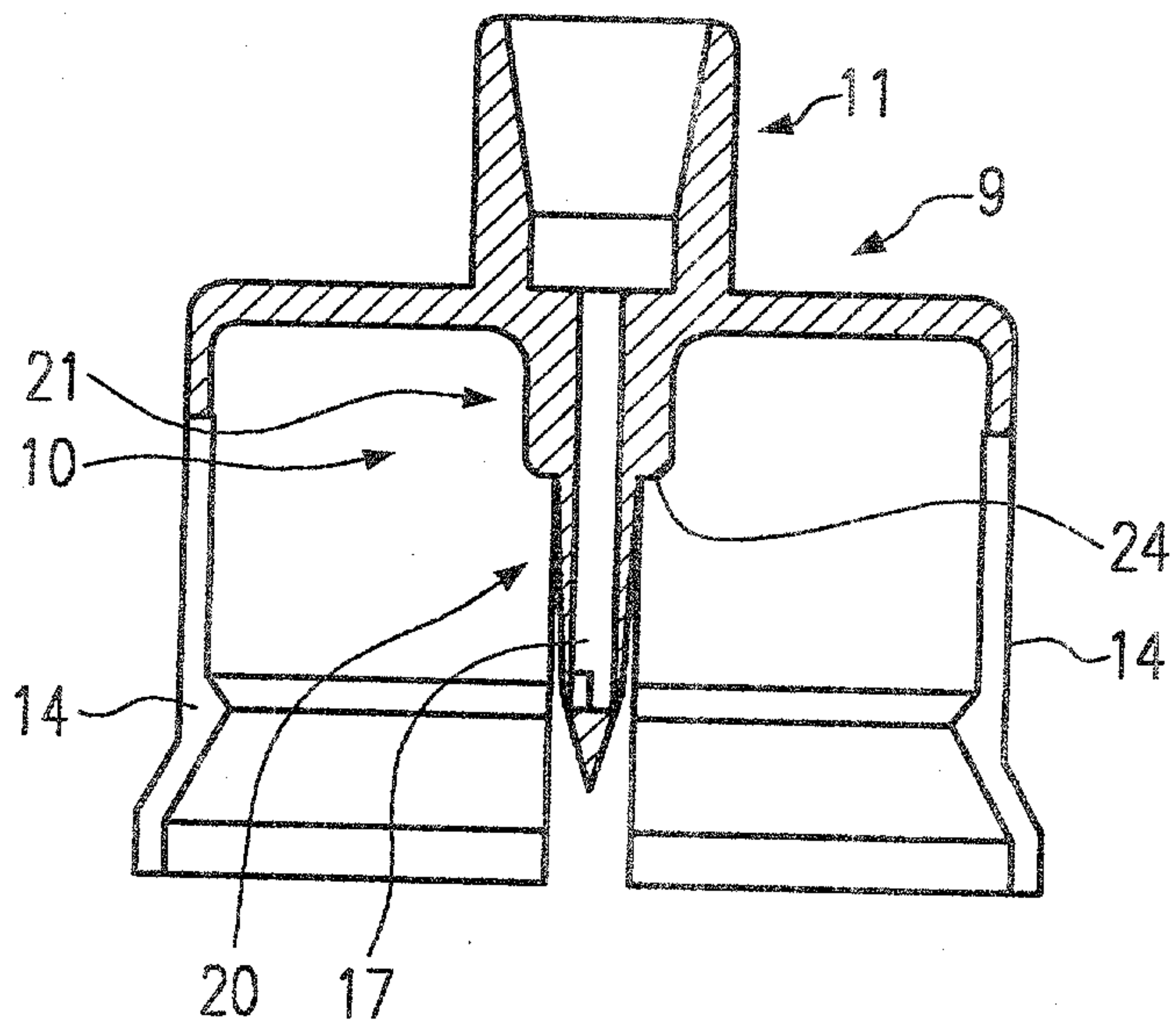

Fig. 9

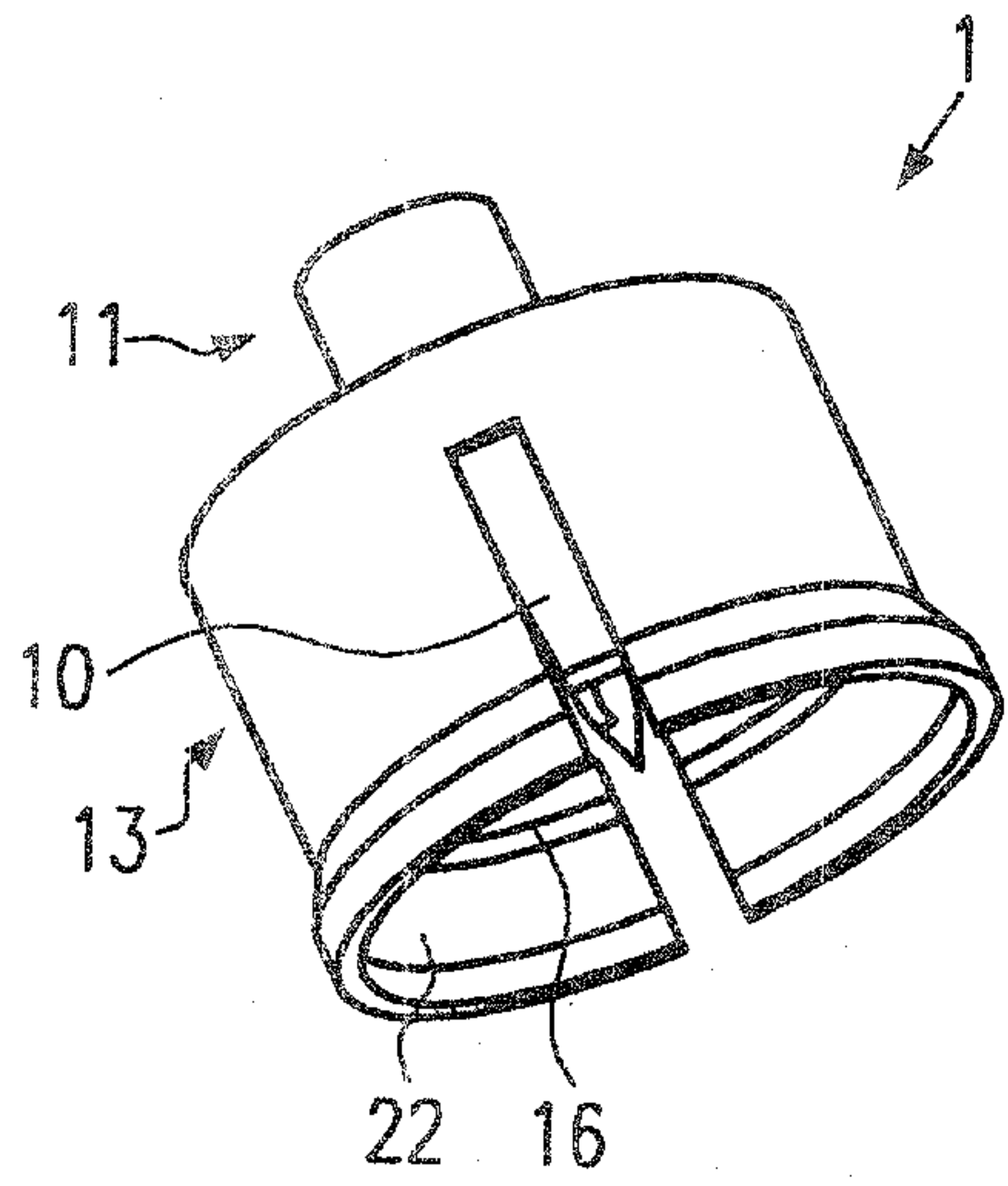

Fig. 8

