



(19) **United States**
(12) **Patent Application Publication**
Ghosh et al.

(10) **Pub. No.: US 2012/0327871 A1**
(43) **Pub. Date: Dec. 27, 2012**

(54) **NON-LEGACY PREAMBLE FOR WIRELESS LOCAL AREA NETWORKS**

filed on Jan. 13, 2012, provisional application No. 61/607,345, filed on Mar. 6, 2012, provisional application No. 61/645,948, filed on May 11, 2012.

(75) Inventors: **Monisha Ghosh**, Chappaqua, NY (US);
Nirav B. Shah, San Diego, CA (US);
Sudheer A. Grandhi, Pleasanton, CA (US);
Ronald G. Murias, Calgary (CA);
Guodong Zhang, Syosset, NY (US);
Xiaofei Wang, Cedar Grove, NJ (US);
Hanqing Lou, Mineola, NY (US);
Robert L. Olesen, Huntington, NY (US)

Publication Classification

(51) **Int. Cl.**
H04W 72/04 (2009.01)
(52) **U.S. Cl.** **370/329**

(73) Assignee: **INTERDIGITAL PATENT HOLDINGS, INC.**, Wilmington, DE (US)

(57) **ABSTRACT**

Method and apparatus for transmission and reception of a Greenfield preamble are provided. In the method and apparatus, the Greenfield preamble may be a single user (SU) preamble or a multi user (MU) preamble. As an MU preamble, the Greenfield preamble includes a short training field (STF), a first long training field (LTF), a first signal (SIG) field, at least one additional LTF, and a second SIG field. Additionally, the Greenfield preamble may be utilized for efficient transmission and reception of control information to wireless devices, whereby the control information may be indicated using the STF, the first LTF, or the first or second SIG fields.

(21) Appl. No.: **13/530,576**

(22) Filed: **Jun. 22, 2012**

Related U.S. Application Data

(60) Provisional application No. 61/500,930, filed on Jun. 24, 2011, provisional application No. 61/586,525,

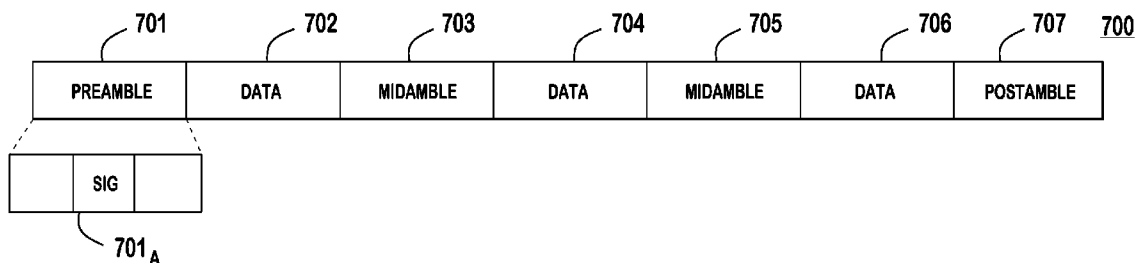

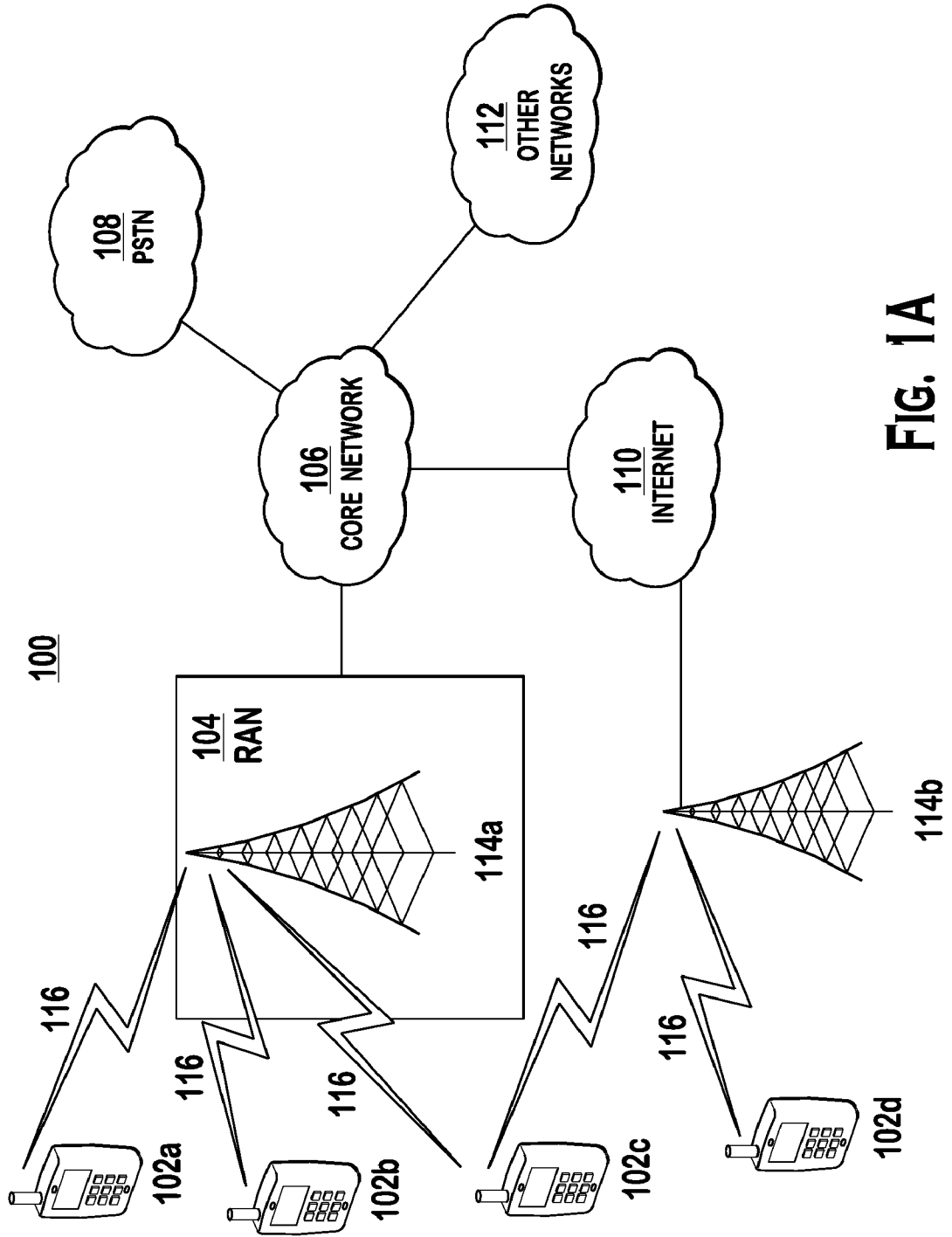

FIG. 1A

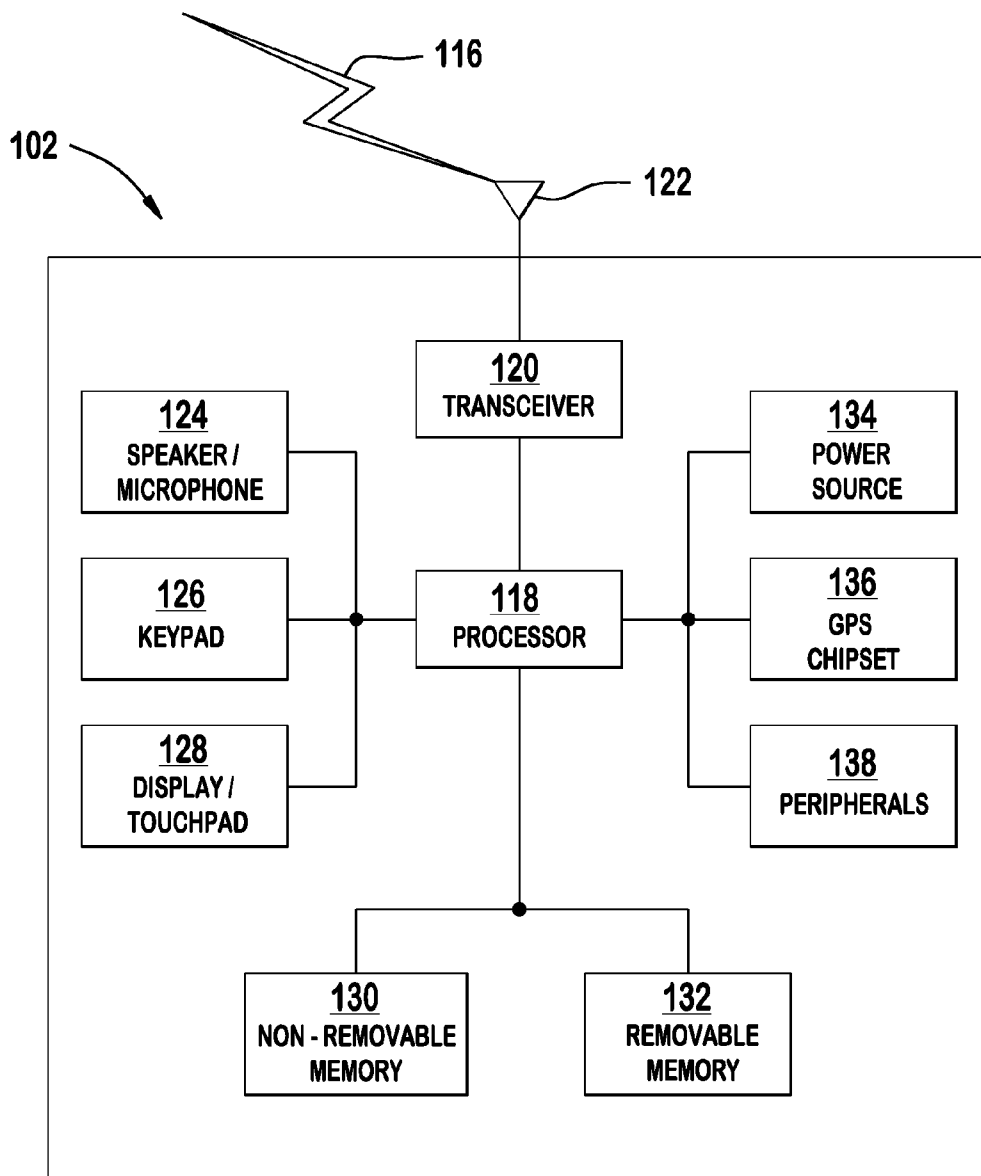

FIG. 1B

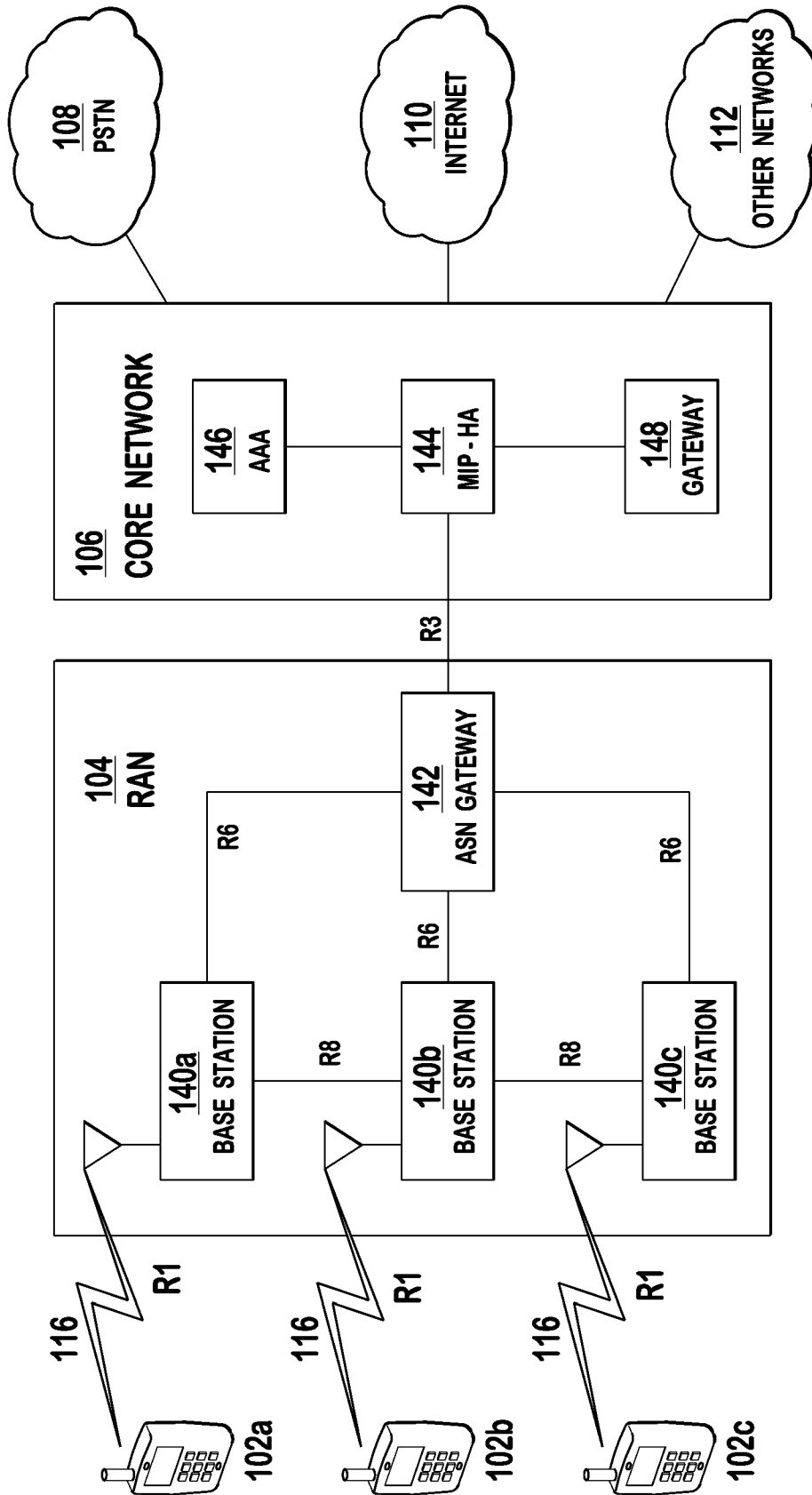

FIG. 1C



FIG. 2

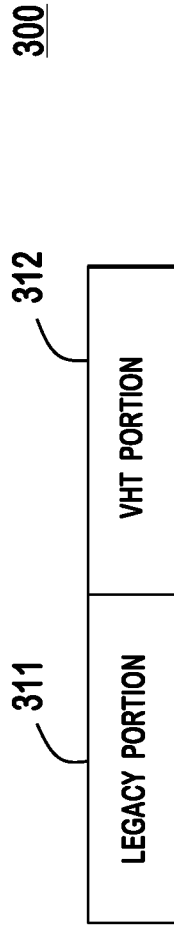

FIG. 3A

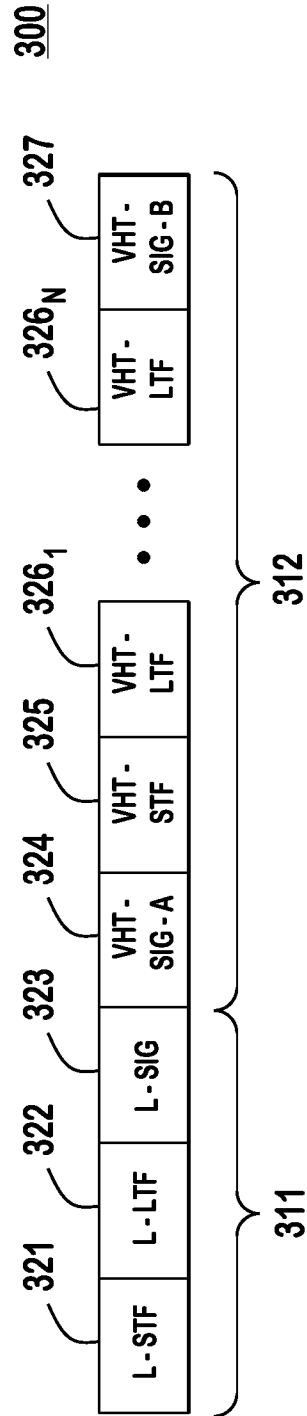

FIG. 3B

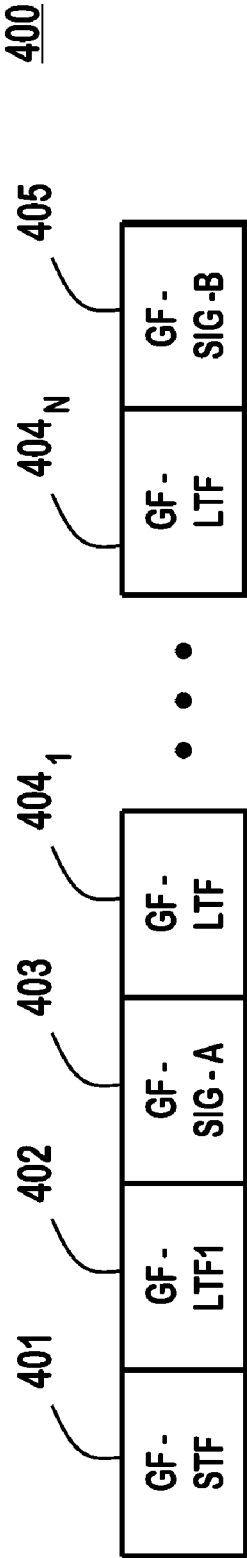

FIG. 4A

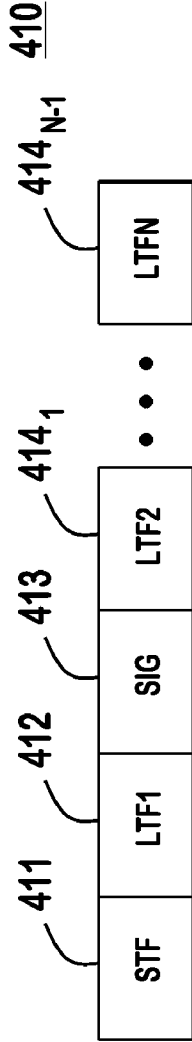

FIG. 4B

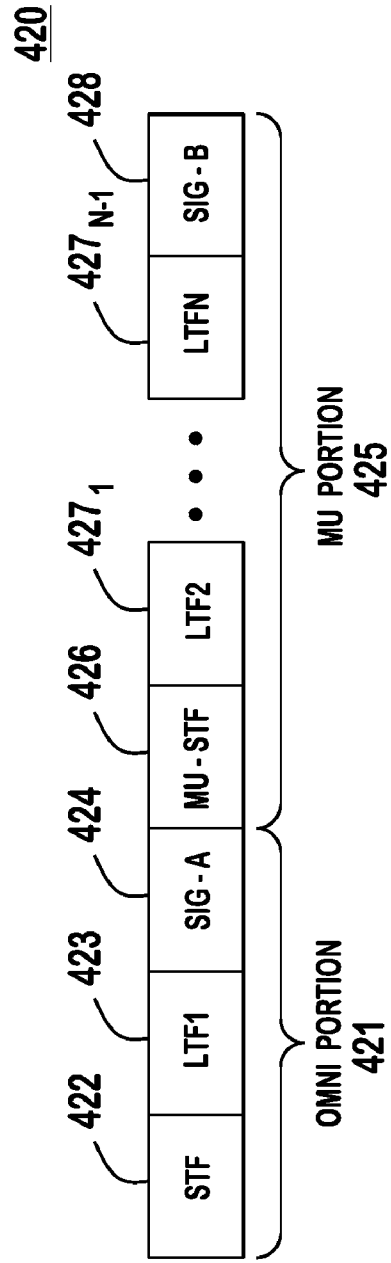

FIG. 4C

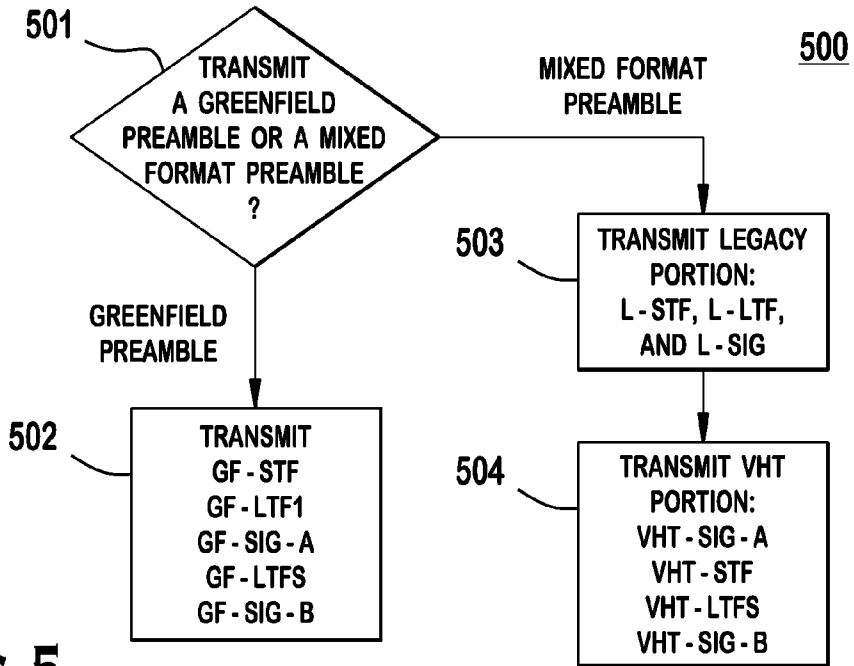

FIG. 5

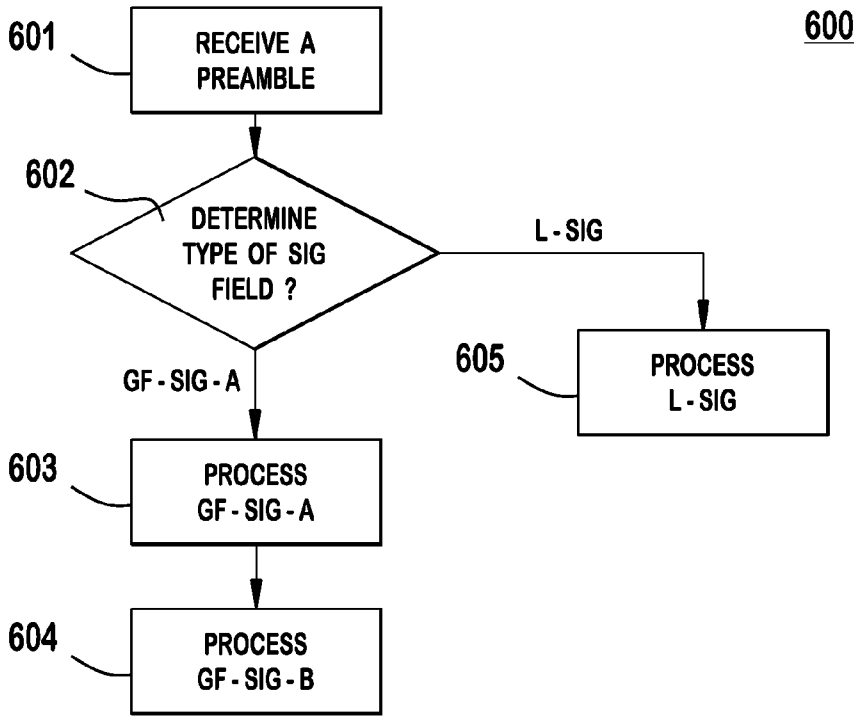
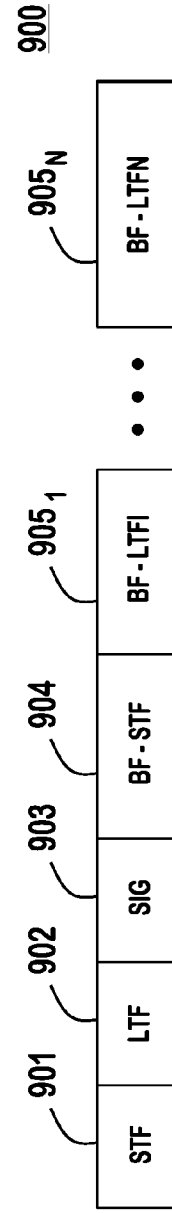
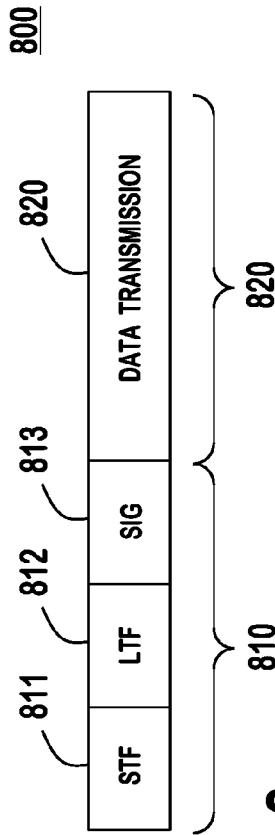
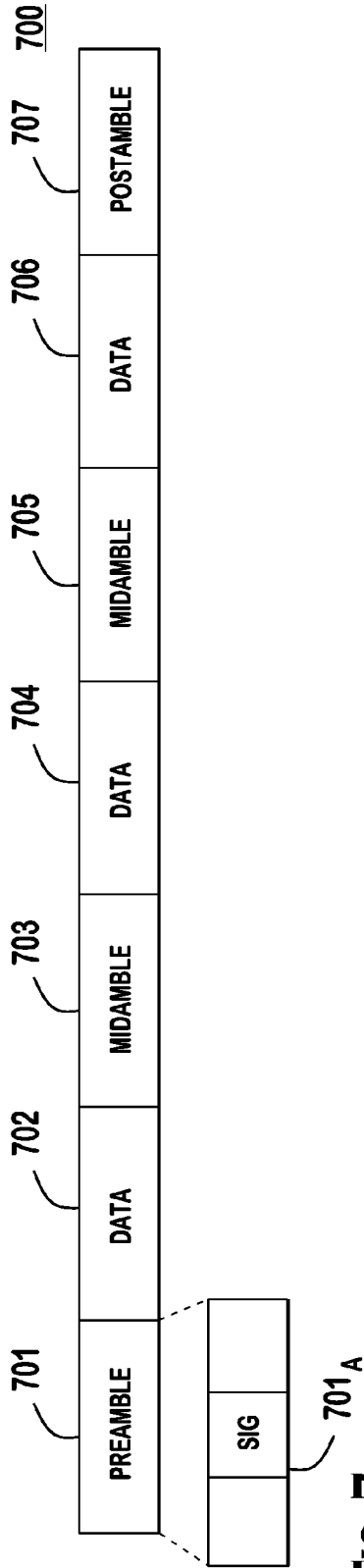

FIG. 6



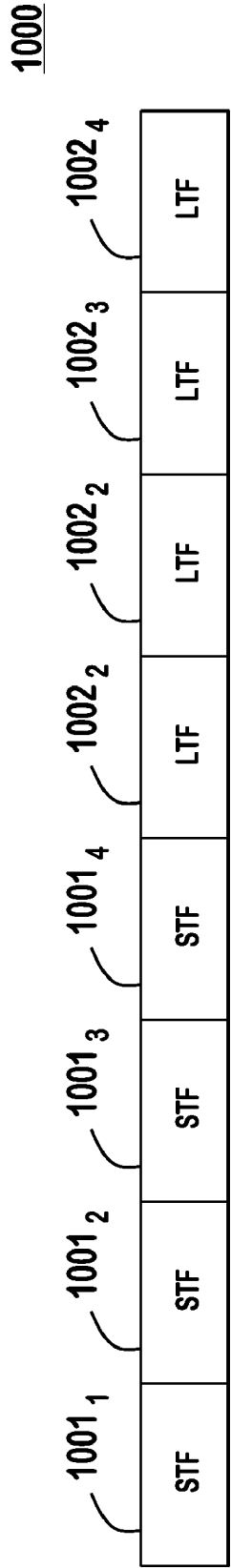

FIG. 10A

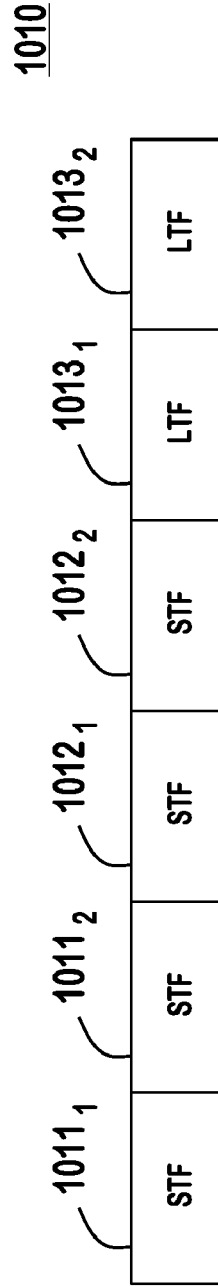

FIG. 10B

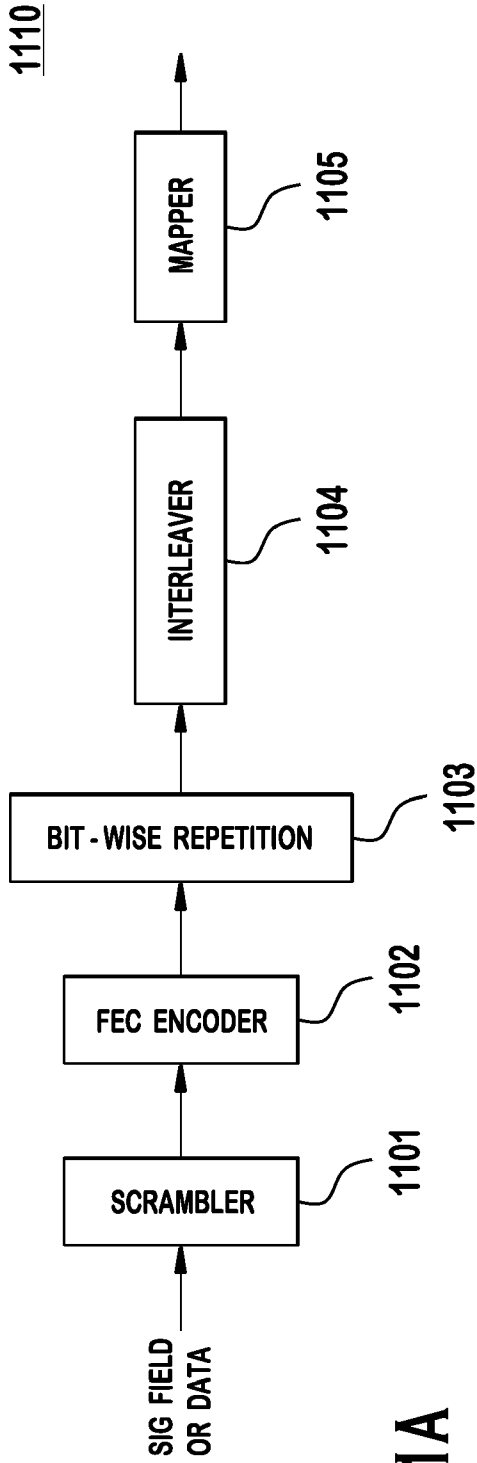

FIG. 11A

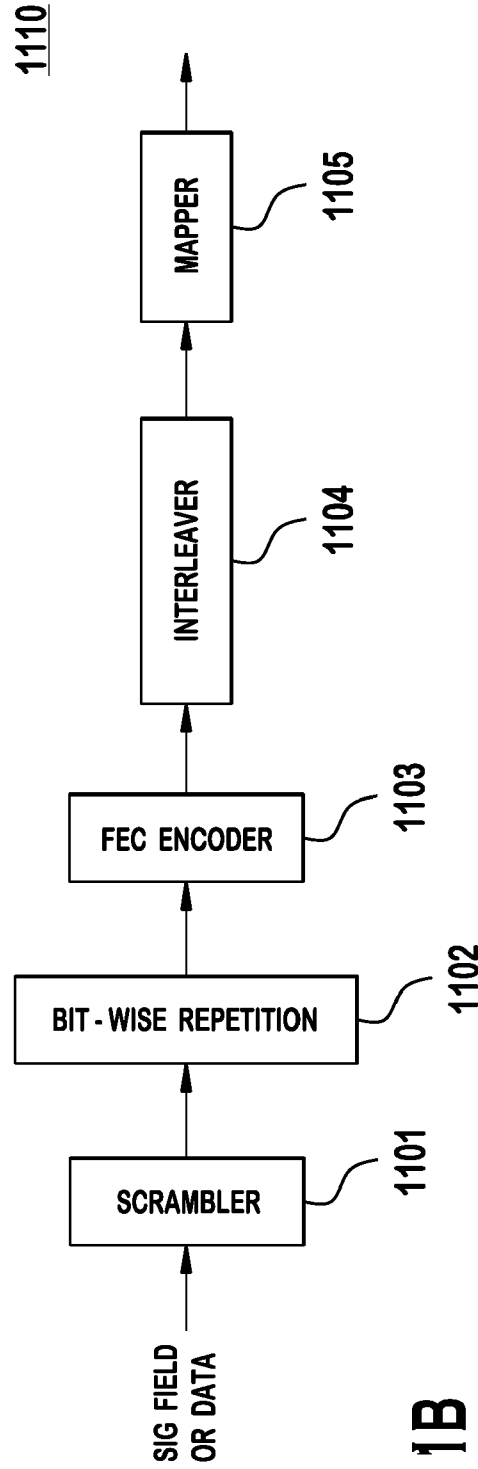

FIG. 11B

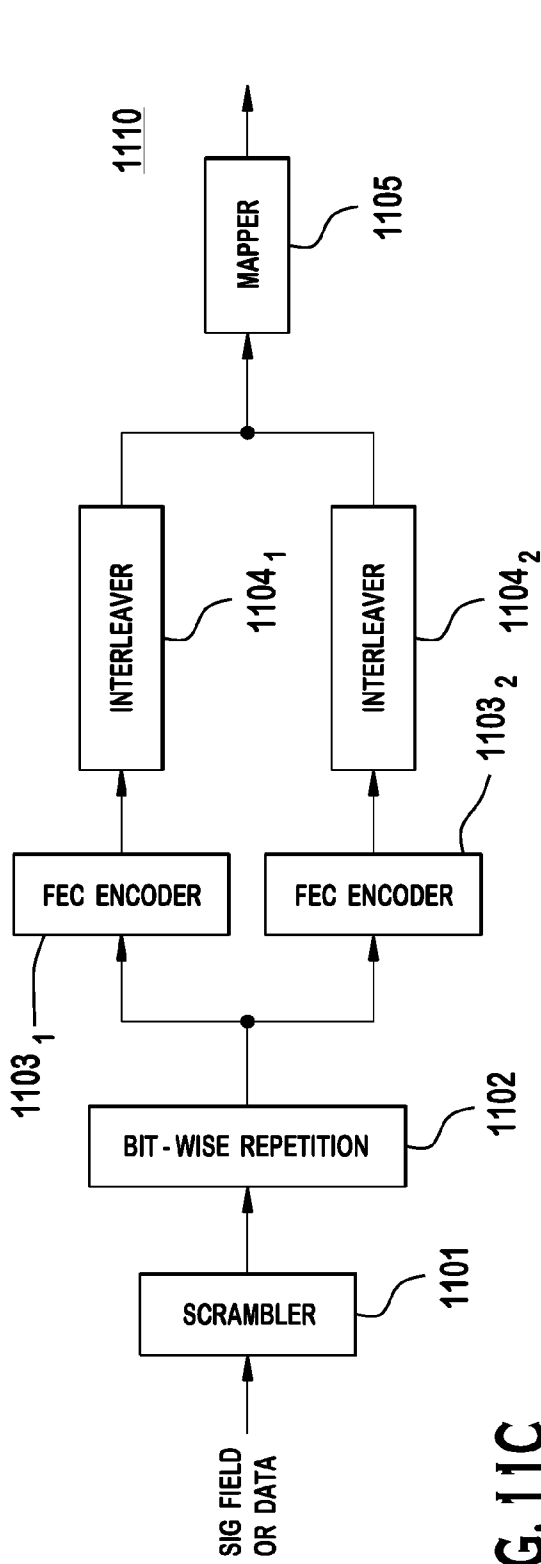

FIG. 11C

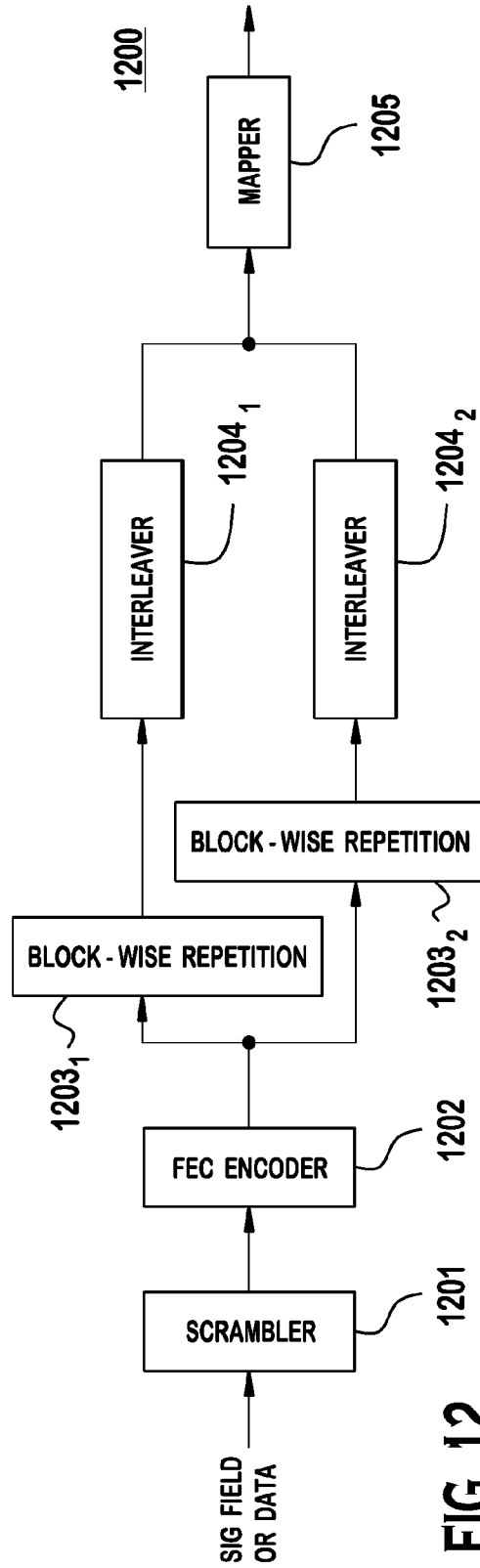

FIG. 12

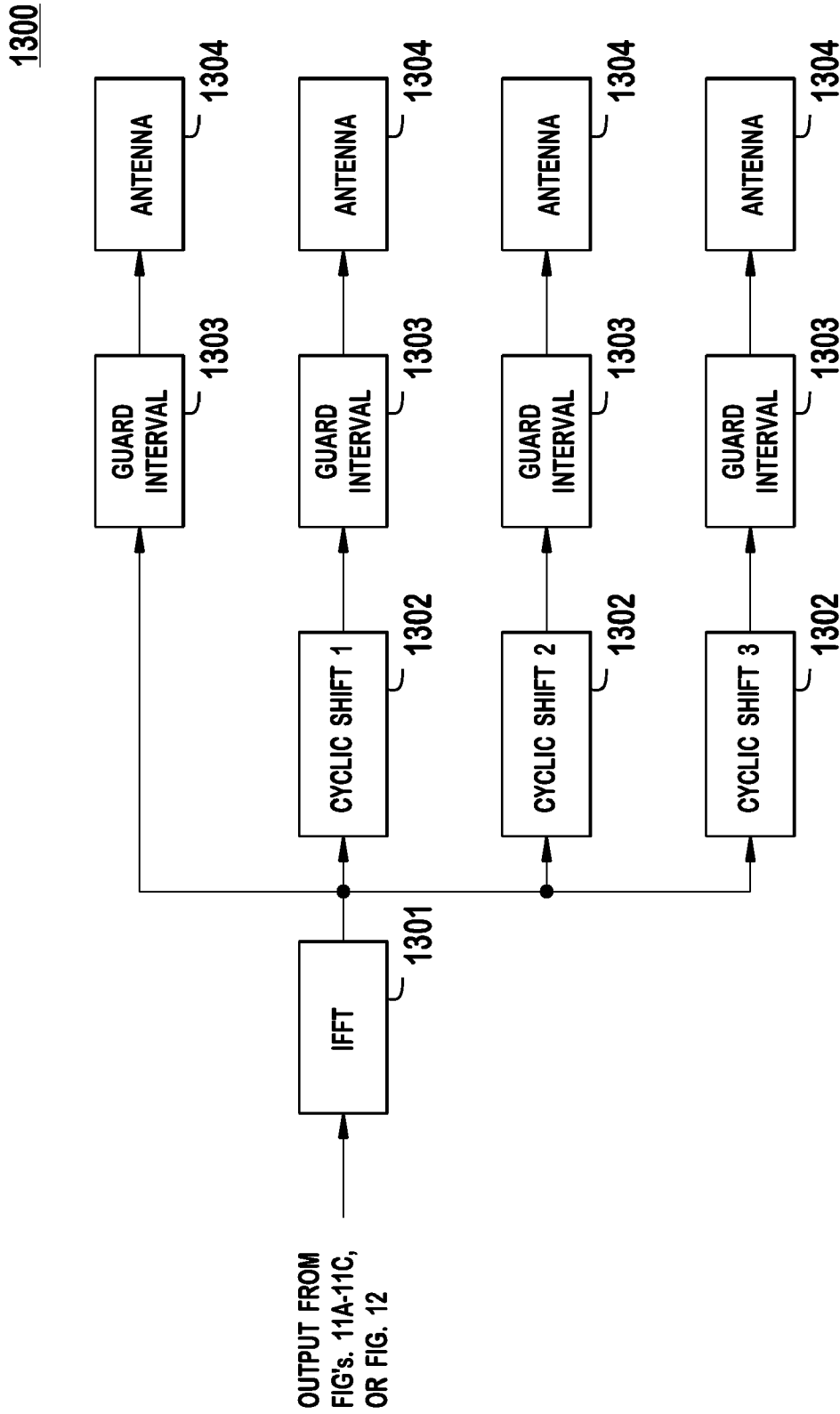

FIG. 13

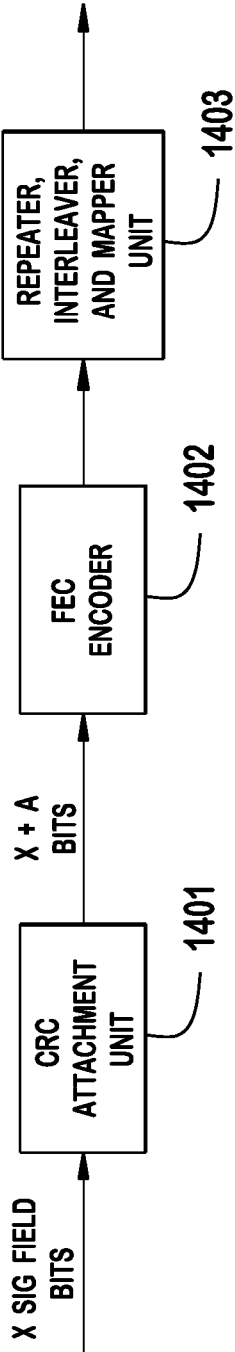

FIG. 14A

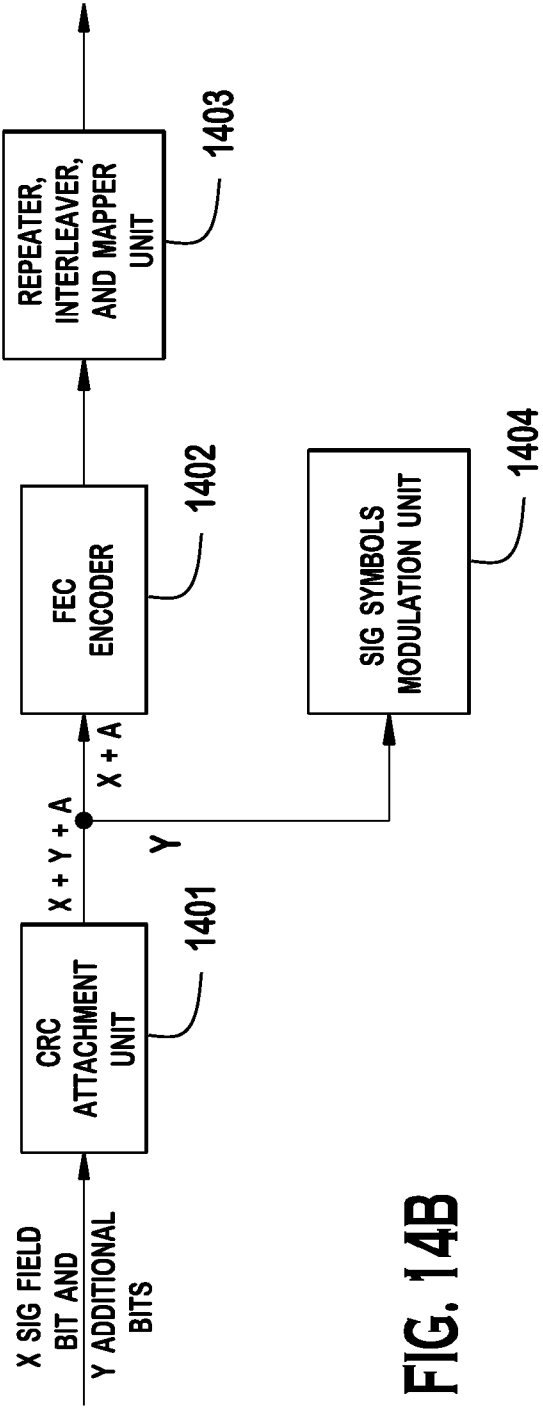

FIG. 14B

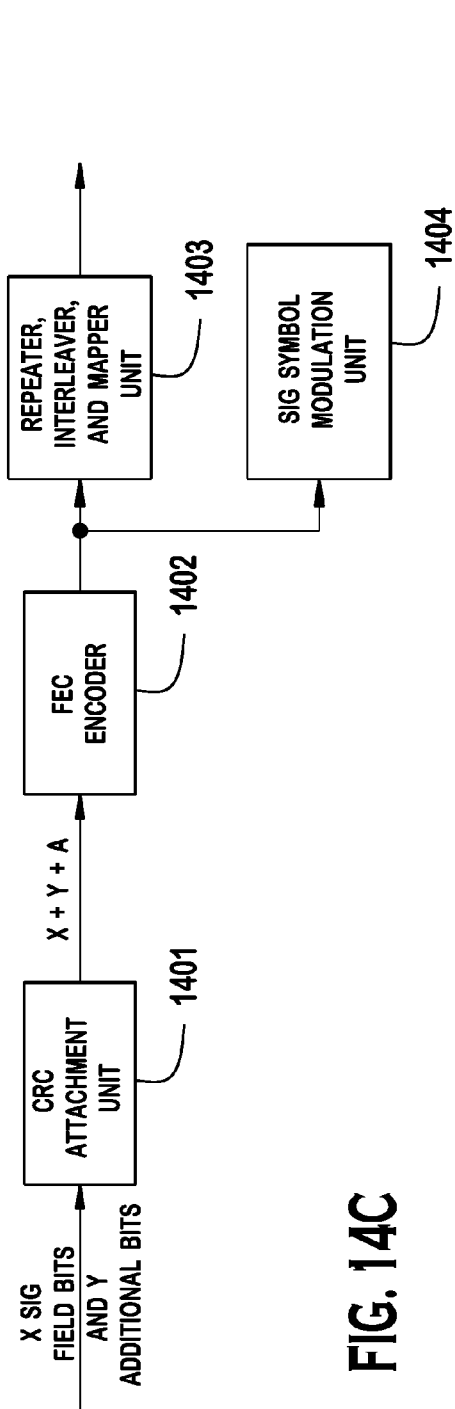

FIG. 14C

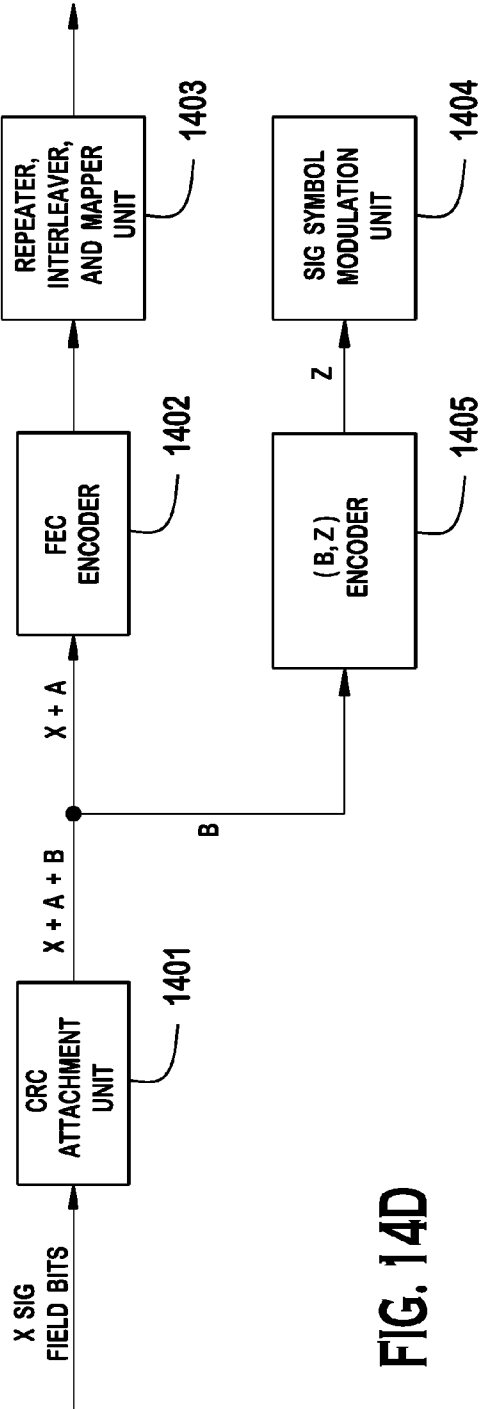

FIG. 14D

NON-LEGACY PREAMBLE FOR WIRELESS LOCAL AREA NETWORKS

CROSS REFERENCE TO RELATED APPLICATIONS

[0001] This application claims the benefit of U.S. provisional application No. 61/500,930 filed on Jun. 24, 2011, U.S. provisional application No. 61/586,525 filed on Jan. 13, 2012, U.S. provisional application No. 61/607,345 filed on Mar. 6, 2012, and U.S. provisional application No. 61/645,948 filed on May 11, 2012, the contents of which are hereby incorporated by reference herein as if fully set forth.

BACKGROUND

[0002] The usage of preambles is very common in wireless communication systems. Preambles provide efficient and effective ways for communications devices to obtain channel conditions. In addition, preambles are also useful for relaying control information to communications devices, including modes of operation and the manner in which data is to be transmitted or received in a communications system.

[0003] In some communications systems, preambles are transmitted before every data transmission and, therefore, the preambles often occupy a large portion of the volume of traffic in a communications system. Additionally, as communications systems become more advanced and incorporate various technologies, preambles are expected to carry more control information often using shrinking bandwidth resources.

[0004] It is, therefore, desirable to have a method and apparatus for preamble transmission and reception in which preambles efficiently relay information between communications devices. It is also desirable for the preambles to be compliant with advanced communications protocols.

SUMMARY

[0005] Method and wireless transmit/receive unit (WTRU) for receiving a preamble in multi-user (MU) multiple input multiple output (MIMO) communications are provided. In the method and WTRU, the preamble comprising a short training field (STF), a first long training field (LTF), a first signal (SIG) field, one or more additional LTFs, and a second SIG field is received. The preamble may be a multi-user (MU) preamble. Further in the method and WTRU, time or frequency acquisition may be performed based on the STF and channel estimation may be performed based on the first LTF. Additionally, in the method and WTRU, a first control information is obtained from the first SIG field and a second control information is obtained from the second SIG field, whereby the first control information is associated with multiple receivers and the second control information is associated with a subset of the multiple receivers.

[0006] In one embodiment, the first LTF may comprise two long training symbols preceded by a double length cyclic prefix and in another embodiment, the first SIG field may indicate whether the preamble is a single user (SU) preamble or a multi user (MU) preamble. In a further embodiment, cyclic redundancy check (CRC) masking of the first field may indicate whether the preamble is an SU preamble or an MU preamble. In an additional embodiment, the first SIG field or the second SIG field may indicate an operating bandwidth or whether data transmission is aggregated.

BRIEF DESCRIPTION OF THE DRAWINGS

[0007] A more detailed understanding may be had from the following description, given by way of example in conjunction with the accompanying drawings wherein:

[0008] FIG. 1A is a system diagram of an example communications system in which one or more disclosed embodiments may be implemented;

[0009] FIG. 1B is a system diagram of an example wireless transmit/receive unit (WTRU) that may be used within the communications system illustrated in FIG. 1A;

[0010] FIG. 1C is a system diagram of an example radio access network and an example core network that may be used within the communications system illustrated in FIG. 1A;

[0011] FIG. 2 shows a preamble for a data transmission;

[0012] FIG. 3A shows a mixed format preamble;

[0013] FIG. 3B shows an example of a mixed format preamble;

[0014] FIG. 4A shows a Greenfield preamble;

[0015] FIG. 4B shows an single user preamble in accordance with the Greenfield preamble;

[0016] FIG. 4C shows an multi user preamble in accordance with the Greenfield preamble;

[0017] FIG. 5 shows a method for preamble transmission;

[0018] FIG. 6 shows a method for processing a preamble;

[0019] FIG. 7 shows a transmission including a preamble, midamble, and a postamble;

[0020] FIG. 8 shows a preamble indicating a short guard interval and a data transmission;

[0021] FIG. 9 shows a beamforming preamble;

[0022] FIG. 10A shows a preamble having four 12-tone short training fields (STFs) and four long training fields (LTFs);

[0023] FIG. 10B shows a preamble having two 12-tone STFs, two 6-tone STFs and two LTFs;

[0024] FIG. 11A shows an example of bit-wise repetition performed after forward error correction (FEC) encoding;

[0025] FIG. 11B shows bit-wise repetition performed before FEC encoding;

[0026] FIG. 11C shows bit-wise repetition performed before FEC encoding;

[0027] FIG. 12 shows an example of block-wise repetition performed after FEC encoding;

[0028] FIG. 13 shows transmission of a SIG field or data using antenna diversity and cyclic shifts;

[0029] FIG. 14A shows an example of coding of signal (SIG) field bits;

[0030] FIG. 14B shows an example of coding of SIG field bits and additional bits;

[0031] FIG. 14C shows an example of coding of SIG field bits and additional bits; and

[0032] FIG. 14D shows an example of coding of SIG field bits and additional cyclic redundancy check (CRC) bits.

DETAILED DESCRIPTION

[0033] FIG. 1A is a diagram of an example communications system 100 in which one or more disclosed embodiments may be implemented. The communications system 100 may be a multiple access system that provides content, such as voice, data, video, messaging, broadcast, etc., to multiple wireless users. The communications system 100 may enable multiple wireless users to access such content through the sharing of system resources, including wireless bandwidth.

For example, the communications systems **100** may employ one or more channel access methods, such as code division multiple access (CDMA), time division multiple access (TDMA), frequency division multiple access (FDMA), orthogonal FDMA (OFDMA), single-carrier FDMA (SC-FDMA), and the like.

[0034] As shown in FIG. 1A, the communications system **100** may include wireless transmit/receive units (WTRUs) **102a, 102b, 102c, 102d**, a radio access network (RAN) **104**, a core network **106**, a public switched telephone network (PSTN) **108**, the Internet **110**, and other networks **112**, though it will be appreciated that the disclosed embodiments contemplate any number of WTRUs, base stations, networks, and/or network elements. Each of the WTRUs **102a, 102b, 102c, 102d** may be any type of device configured to operate and/or communicate in a wireless environment. By way of example, the WTRUs **102a, 102b, 102c, 102d** may be configured to transmit and/or receive wireless signals and may include user equipment (UE), a mobile station, a fixed or mobile subscriber unit, a pager, a cellular telephone, a personal digital assistant (PDA), a smartphone, a laptop, a netbook, a personal computer, a wireless sensor, consumer electronics, and the like.

[0035] The communications systems **100** may also include a base station **114a** and a base station **114b**. Each of the base stations **114a, 114b** may be any type of device configured to wirelessly interface with at least one of the WTRUs **102a, 102b, 102c, 102d** to facilitate access to one or more communication networks, such as the core network **106**, the Internet **110**, and/or the networks **112**. By way of example, the base stations **114a, 114b** may be a base transceiver station (BTS), a Node-B, an eNode B, a Home Node B, a Home eNode B, a site controller, an access point (AP), a wireless router, and the like. While the base stations **114a, 114b** are each depicted as a single element, it will be appreciated that the base stations **114a, 114b** may include any number of interconnected base stations and/or network elements.

[0036] The base station **114a** may be part of the RAN **104**, which may also include other base stations and/or network elements (not shown), such as a base station controller (BSC), a radio network controller (RNC), relay nodes, etc. The base station **114a** and/or the base station **114b** may be configured to transmit and/or receive wireless signals within a particular geographic region, which may be referred to as a cell (not shown). The cell may further be divided into cell sectors. For example, the cell associated with the base station **114a** may be divided into three sectors. Thus, in one embodiment, the base station **114a** may include three transceivers, i.e., one for each sector of the cell. In another embodiment, the base station **114a** may employ multiple-input multiple output (MIMO) technology and, therefore, may utilize multiple transceivers for each sector of the cell.

[0037] The base stations **114a, 114b** may communicate with one or more of the WTRUs **102a, 102b, 102c, 102d** over an air interface **116**, which may be any suitable wireless communication link (e.g., radio frequency (RF), microwave, infrared (IR), ultraviolet (UV), visible light, etc.). The air interface **116** may be established using any suitable radio access technology (RAT).

[0038] More specifically, as noted above, the communications system **100** may be a multiple access system and may employ one or more channel access schemes, such as CDMA, TDMA, FDMA, OFDMA, SC-FDMA, and the like. For example, the base station **114a** in the RAN **104** and the

WTRUs **102a, 102b, 102c** may implement a radio technology such as Universal Mobile Telecommunications System (UMTS) Terrestrial Radio Access (UTRA), which may establish the air interface **116** using wideband CDMA (WCDMA). WCDMA may include communication protocols such as High-Speed Packet Access (HSPA) and/or Evolved HSPA (HSPA+). HSPA may include High-Speed Downlink Packet Access (HSDPA) and/or High-Speed Uplink Packet Access (HSUPA).

[0039] In another embodiment, the base station **114a** and the WTRUs **102a, 102b, 102c** may implement a radio technology such as Evolved UMTS Terrestrial Radio Access (E-UTRA), which may establish the air interface **116** using Long Term Evolution (LTE) and/or LTE-Advanced (LTE-A).

[0040] In other embodiments, the base station **114a** and the WTRUs **102a, 102b, 102c** may implement radio technologies such as Institute for Electrical and Electronics Engineers (IEEE) 802.16 (i.e., Worldwide Interoperability for Microwave Access (WiMAX)), CDMA2000, CDMA2000 1X, CDMA2000 EV-DO, Interim Standard 2000 (IS-2000), Interim Standard 95 (IS-95), Interim Standard 856 (IS-856), Global System for Mobile communications (GSM), Enhanced Data rates for GSM Evolution (EDGE), GSM EDGE (GERAN), and the like.

[0041] The base station **114b** in FIG. 1A may be a wireless router, Home Node B, Home eNode B, or access point, for example, and may utilize any suitable RAT for facilitating wireless connectivity in a localized area, such as a place of business, a home, a vehicle, a campus, and the like. In one embodiment, the base station **114b** and the WTRUs **102c, 102d** may implement a radio technology such as IEEE 802.11 to establish a wireless local area network (WLAN). In another embodiment, the base station **114b** and the WTRUs **102c, 102d** may implement a radio technology such as IEEE 802.15 to establish a wireless personal area network (WPAN). In yet another embodiment, the base station **114b** and the WTRUs **102c, 102d** may utilize a cellular-based RAT (e.g., WCDMA, CDMA2000, GSM, LTE, LTE-A, etc.) to establish a picocell or femtocell. As shown in FIG. 1A, the base station **114b** may have a direct connection to the Internet **110**. Thus, the base station **114b** may not be required to access the Internet **110** via the core network **106**.

[0042] The RAN **104** may be in communication with the core network **106**, which may be any type of network configured to provide voice, data, applications, and/or voice over internet protocol (VoIP) services to one or more of the WTRUs **102a, 102b, 102c, 102d**. For example, the core network **106** may provide call control, billing services, mobile location-based services, pre-paid calling, Internet connectivity, video distribution, etc., and/or perform high-level security functions, such as user authentication. Although not shown in FIG. 1A, it will be appreciated that the RAN **104** and/or the core network **106** may be in direct or indirect communication with other RANs that employ the same RAT as the RAN **104** or a different RAT. For example, in addition to being connected to the RAN **104**, which may be utilizing an E-UTRA radio technology, the core network **106** may also be in communication with another RAN (not shown) employing a GSM radio technology.

[0043] The core network **106** may also serve as a gateway for the WTRUs **102a, 102b, 102c, 102d** to access the PSTN **108**, the Internet **110**, and/or other networks **112**. The PSTN **108** may include circuit-switched telephone networks that provide plain old telephone service (POTS). The Internet **110**

may include a global system of interconnected computer networks and devices that use common communication protocols, such as the transmission control protocol (TCP), user datagram protocol (UDP) and the internet protocol (IP) in the TCP/IP internet protocol suite. The networks **112** may include wired or wireless communications networks owned and/or operated by other service providers. For example, the networks **112** may include another core network connected to one or more RANs, which may employ the same RAT as the RAN **104** or a different RAT.

[0044] Some or all of the WTRUs **102a**, **102b**, **102c**, **102d** in the communications system **100** may include multi-mode capabilities, i.e., the WTRUs **102a**, **102b**, **102c**, **102d** may include multiple transceivers for communicating with different wireless networks over different wireless links. For example, the WTRU **102c** shown in FIG. 1A may be configured to communicate with the base station **114a**, which may employ a cellular-based radio technology, and with the base station **114b**, which may employ an IEEE 802 radio technology.

[0045] FIG. 1B is a system diagram of an example WTRU **102**. As shown in FIG. 1B, the WTRU **102** may include a processor **118**, a transceiver **120**, a transmit/receive element **122**, a speaker/microphone **124**, a keypad **126**, a display/touchpad **128**, non-removable memory **130**, removable memory **132**, a power source **134**, a global positioning system (GPS) chipset **136**, and other peripherals **138**. It will be appreciated that the WTRU **102** may include any sub-combination of the foregoing elements while remaining consistent with an embodiment.

[0046] The processor **118** may be a general purpose processor, a special purpose processor, a conventional processor, a digital signal processor (DSP), a plurality of microprocessors, one or more microprocessors in association with a DSP core, a controller, a microcontroller, Application Specific Integrated Circuits (ASICs), Field Programmable Gate Array (FPGAs) circuits, any other type of integrated circuit (IC), a state machine, and the like. The processor **118** may perform signal coding, data processing, power control, input/output processing, and/or any other functionality that enables the WTRU **102** to operate in a wireless environment. The processor **118** may be coupled to the transceiver **120**, which may be coupled to the transmit/receive element **122**. While FIG. 1B depicts the processor **118** and the transceiver **120** as separate components, it will be appreciated that the processor **118** and the transceiver **120** may be integrated together in an electronic package or chip.

[0047] The transmit/receive element **122** may be configured to transmit signals to, or receive signals from, a base station (e.g., the base station **114a**) over the air interface **116**. For example, in one embodiment, the transmit/receive element **122** may be an antenna configured to transmit and/or receive RF signals. In another embodiment, the transmit/receive element **122** may be an emitter/detector configured to transmit and/or receive IR, UV, or visible light signals, for example. In yet another embodiment, the transmit/receive element **122** may be configured to transmit and receive both RF and light signals. It will be appreciated that the transmit/receive element **122** may be configured to transmit and/or receive any combination of wireless signals.

[0048] In addition, although the transmit/receive element **122** is depicted in FIG. 1B as a single element, the WTRU **102** may include any number of transmit/receive elements **122**. More specifically, the WTRU **102** may employ MIMO tech-

nology. Thus, in one embodiment, the WTRU **102** may include two or more transmit/receive elements **122** (e.g., multiple antennas) for transmitting and receiving wireless signals over the air interface **116**.

[0049] The transceiver **120** may be configured to modulate the signals that are to be transmitted by the transmit/receive element **122** and to demodulate the signals that are received by the transmit/receive element **122**. As noted above, the WTRU **102** may have multi-mode capabilities. Thus, the transceiver **120** may include multiple transceivers for enabling the WTRU **102** to communicate via multiple RATs, such as UTRA and IEEE 802.11, for example.

[0050] The processor **118** of the WTRU **102** may be coupled to, and may receive user input data from, the speaker/microphone **124**, the keypad **126**, and/or the display/touchpad **128** (e.g., a liquid crystal display (LCD) display unit or organic light-emitting diode (OLED) display unit). The processor **118** may also output user data to the speaker/microphone **124**, the keypad **126**, and/or the display/touchpad **128**. In addition, the processor **118** may access information from, and store data in, any type of suitable memory, such as the non-removable memory **130** and/or the removable memory **132**. The non-removable memory **130** may include random-access memory (RAM), read-only memory (ROM), a hard disk, or any other type of memory storage device. The removable memory **132** may include a subscriber identity module (SIM) card, a memory stick, a secure digital (SD) memory card, and the like. In other embodiments, the processor **118** may access information from, and store data in, memory that is not physically located on the WTRU **102**, such as on a server or a home computer (not shown).

[0051] The processor **118** may receive power from the power source **134**, and may be configured to distribute and/or control the power to the other components in the WTRU **102**. The power source **134** may be any suitable device for powering the WTRU **102**. For example, the power source **134** may include one or more dry cell batteries (e.g., nickel-cadmium (NiCd), nickel-zinc (NiZn), nickel metal hydride (NiMH), lithium-ion (Li-ion), etc.), solar cells, fuel cells, and the like.

[0052] The processor **118** may also be coupled to the GPS chipset **136**, which may be configured to provide location information (e.g., longitude and latitude) regarding the current location of the WTRU **102**. In addition to, or in lieu of, the information from the GPS chipset **136**, the WTRU **102** may receive location information over the air interface **116** from a base station (e.g., base stations **114a**, **114b**) and/or determine its location based on the timing of the signals being received from two or more nearby base stations. It will be appreciated that the WTRU **102** may acquire location information by way of any suitable location-determination method while remaining consistent with an embodiment.

[0053] The processor **118** may further be coupled to other peripherals **138**, which may include one or more software and/or hardware modules that provide additional features, functionality and/or wired or wireless connectivity. For example, the peripherals **138** may include an accelerometer, an e-compass, a satellite transceiver, a digital camera (for photographs or video), a universal serial bus (USB) port, a vibration device, a television transceiver, a hands free headset, a Bluetooth® module, a frequency modulated (FM) radio unit, a digital music player, a media player, a video game player module, an Internet browser, and the like.

[0054] FIG. 1C is a system diagram of the RAN **104** and the core network **106** according to an embodiment. The RAN **104**

may be an access service network (ASN) that employs IEEE 802.16 radio technology to communicate with the WTRUs **102a**, **102b**, **102c** over the air interface **116**. As will be further discussed below, the communication links between the different functional entities of the WTRUs **102a**, **102b**, **102c**, the RAN **104**, and the core network **106** may be defined as reference points.

[0055] As shown in FIG. 1C, the RAN **104** may include base stations **140a**, **140b**, **140c**, and an ASN gateway **142**, though it will be appreciated that the RAN **104** may include any number of base stations and ASN gateways while remaining consistent with an embodiment. The base stations **140a**, **140b**, **140c** may each be associated with a particular cell (not shown) in the RAN **104** and may each include one or more transceivers for communicating with the WTRUs **102a**, **102b**, **102c** over the air interface **116**. In one embodiment, the base stations **140a**, **140b**, **140c** may implement MIMO technology. Thus, the base station **140a**, for example, may use multiple antennas to transmit wireless signals to, and receive wireless signals from, the WTRU **102a**. The base stations **140a**, **140b**, **140c** may also provide mobility management functions, such as handoff triggering, tunnel establishment, radio resource management, traffic classification, quality of service (QoS) policy enforcement, and the like. The ASN gateway **142** may serve as a traffic aggregation point and may be responsible for paging, caching of subscriber profiles, routing to the core network **106**, and the like.

[0056] The air interface **116** between the WTRUs **102a**, **102b**, **102c** and the RAN **104** may be defined as an R1 reference point that implements the IEEE 802.16 specification. In addition, each of the WTRUs **102a**, **102b**, **102c** may establish a logical interface (not shown) with the core network **106**. The logical interface between the WTRUs **102a**, **102b**, **102c** and the core network **106** may be defined as an R2 reference point, which may be used for authentication, authorization, IP host configuration management, and/or mobility management.

[0057] The communication link between each of the base stations **140a**, **140b**, **140c** may be defined as an R8 reference point that includes protocols for facilitating WTRU handovers and the transfer of data between base stations. The communication link between the base stations **140a**, **140b**, **140c** and the ASN gateway **215** may be defined as an R6 reference point. The R6 reference point may include protocols for facilitating mobility management based on mobility events associated with each of the WTRUs **102a**, **102b**, **102c**.

[0058] As shown in FIG. 1C, the RAN **104** may be connected to the core network **106**. The communication link between the RAN **104** and the core network **106** may be defined as an R3 reference point that includes protocols for facilitating data transfer and mobility management capabilities, for example. The core network **106** may include a mobile IP home agent (MIP-HA) **144**, an authentication, authorization, accounting (AAA) server **146**, and a gateway **148**. While each of the foregoing elements are depicted as part of the core network **106**, it will be appreciated that any one of these elements may be owned and/or operated by an entity other than the core network operator.

[0059] The MIP-HA may be responsible for IP address management, and may enable the WTRUs **102a**, **102b**, **102c** to roam between different ASNs and/or different core networks. The MIP-HA **144** may provide the WTRUs **102a**, **102b**, **102c** with access to packet-switched networks, such as the Internet **110**, to facilitate communications between the WTRUs **102a**, **102b**, **102c** and IP-enabled devices. The AAA

server **146** may be responsible for user authentication and for supporting user services. The gateway **148** may facilitate interworking with other networks. For example, the gateway **148** may provide the WTRUs **102a**, **102b**, **102c** with access to circuit-switched networks, such as the PSTN **108**, to facilitate communications between the WTRUs **102a**, **102b**, **102c** and traditional land-line communications devices. In addition, the gateway **148** may provide the WTRUs **102a**, **102b**, **102c** with access to the networks **112**, which may include other wired or wireless networks that are owned and/or operated by other service providers.

[0060] Although not shown in FIG. 1C, it will be appreciated that the RAN **104** may be connected to other ASNs and the core network **106** may be connected to other core networks. The communication link between the RAN **104** and the other ASNs may be defined as an R4 reference point, which may include protocols for coordinating the mobility of the WTRUs **102a**, **102b**, **102c** between the RAN **104** and the other ASNs. The communication link between the core network **106** and the other core networks may be defined as an R5 reference point, which may include protocols for facilitating interworking between home core networks and visited core networks.

[0061] When referred to hereinafter, the term transmitter may mean a WTRU, a station (STA), a base station, a node B, or an access point (AP), among others. Further, when referred to hereinafter, the term receiver may mean a WTRU, an STA, a base station, a node B, or an AP, among others. Further, the transmitter or the receiver may communicate using any communications protocol including, but not limited to, an Institute for Electrical and Electronics Engineers (IEEE) 802 communications protocol, such as 802.11n, 802.11ac, 802.11af, or 802.11ah, among others. The transmitter or the receiver may also operate in any spectrum including, but not limited to, a television (TV) whitespace spectrum or a sub-1 gigahertz (GHz) spectrum.

[0062] Preambles are widely used in communications systems. A preamble may be transmitted stand-alone, (i.e., without a subsequent data transmission), or may be a header for a data transmission. The preamble allows for training a receiver to obtain information about channel conditions between a transmitter and the receiver, and thereby improved reception of subsequent data transmissions (for example, user data) is facilitated. In addition to training the receiver, a preamble may be used for sending control information to the receiver that may be necessary for reception of subsequent data transmissions.

[0063] FIG. 2 shows a preamble for a data transmission. In FIG. 2, the preamble **201** is transmitted prior to a data transmission **202**. The preamble **201** may include training symbols that may be used for automatic gain control (AGC), timing and frequency acquisition, or channel estimation by the receiver. Furthermore, the training symbols may be used for frequency or time synchronization between the transmitter and the receiver.

[0064] In addition to the training symbols, the preamble may include dedicated bits that carry control information to the receiver. The dedicated bits may indicate to the receiver a transmission bandwidth, modulation or coding information, beamforming information, or space-time coding information.

[0065] As may be recognized, for proper communication between a transmitter and a receiver, a communications protocol may define a preamble for use in the communications protocol. A communications protocol may define the training

symbols of the preamble and the meaning of the dedicated bits of the preamble. For example, the transmission protocol may define the length of the preamble (in bits, bytes, or symbols), the time or frequency resources used for transmission of the preamble, the encoding or modulation of the preamble, or the interpretation of the dedicated bits of the preamble. A transmitter or a receiver that is compliant with the communications protocol is aware of the manner in which the preamble is defined and may, therefore, successfully interpret and utilize the preamble.

[0066] As communications protocols are updated in order to allow for increased data rates and very high throughput (VHT) or enable usage of additional frequency bandwidths, preambles may also be updated according to the requirements of the communications protocols. Furthermore, transmitters and receivers using the communications protocols are required to be updated in order to be compliant with the latest communications protocols and in order to receive and properly process preambles of the communications protocols. However, it may be desirable for a communications protocol to allow legacy transmitters and receivers, (i.e., transmitters and receivers that are not compliant with the updated communications protocol), to communicate using the updated communications protocols.

[0067] A mixed format preamble may be used to allow legacy transmitters and receivers to communicate using the updated communications protocols. The mixed format preamble has both a legacy portion for use by legacy transmitters and receivers and a non-legacy portion for use by non-legacy transmitters and receivers. The non-legacy portion of the preamble is referred to herein as a very high throughput (VHT) portion. Furthermore, a transmitter or a receiver that is compliant with the updated communications protocols is referred to herein as a VHT transmitter or a VHT receiver or a non-legacy transmitter or a non-legacy receiver.

[0068] FIG. 3A shows a mixed format preamble 300. The mixed format preamble 300 comprises a legacy portion 311 and a VHT portion 312. The legacy portion 311 of the mixed format preamble 300 may comprise training fields and control information fields for use by legacy receivers. Legacy receivers may process the legacy portion 311 of the mixed format preamble 300 and may subsequently be able to interpret the VHT portion 312 using information provided in the legacy portion 311. The VHT portion 312 of the mixed format preamble 300 may comprise training fields and control information fields for use by non-legacy receivers or VHT receivers. Non-legacy receivers or VHT receivers may ignore or skip the legacy portion 311 and only use the VHT portion 312 of the mixed format preamble 300.

[0069] FIG. 3B shows an example of a mixed format preamble. The mixed format preamble 300 comprises a legacy portion 311 and a VHT portion 312. The legacy portion 311 comprises a legacy short training field (STF), referred to herein as L-STF 321, a legacy long training field (LTF), referred to herein as L-LTF 322, and a legacy signal (SIG) field, referred to herein as L-SIG 323. The VHT portion 312 comprises a first VHT SIG field, referred to herein as VHT-SIG-A 324, and a second VHT SIG field, referred to herein as VHT-SIG-B 327, an STF, referred to herein as VHT-STF 325, and one or more LTFs, referred to herein as VHT-LTFs 326_{1-N} and collectively referred to hereinafter as VHT-LTFs 326.

[0070] In the legacy portion 311 of the mixed format preamble 300, L-STF 321 comprises one or more short training symbols and may be used for AGC and timing and frequency

acquisition by a legacy receiver. Further, L-LTF 322 comprises one or more long training symbols and may be used for channel estimation by a receiver. L-SIG 323 may include dedicated bits that signal to a receiver control information, such as bandwidth information, modulation or coding information, and the like.

[0071] Legacy receivers may train for reception of subsequent data transmission based on L-STF 321 and L-LTF 322. Further, legacy receivers may receive control information included in L-SIG 323.

[0072] In the VHT portion 312 of the mixed format preamble 300, VHT-STF 325 comprises one or more short training symbols and may be used for AGC and timing and frequency acquisition by a non-legacy or a VHT receiver. Further, VHT-LTFs 326 comprise one or more long training symbols and may be used for antenna calibration by a non-legacy receiver. VHT-SIG-A 324 and VHT-SIG-B 327 include control information intended for a non-legacy receiver.

[0073] Non-legacy receivers may train using the training symbols of VHT-STF 325 and VHT-LTFs 326. The non-legacy receivers may also receive control information included in VHT-SIG-A 324 and VHT-SIG-B 327. Further, non-legacy receivers may perform AGC and time and frequency acquisition based on VHT-STF 325, and antenna calibration and the like based on VHT-LTFs 326.

[0074] VHT-SIG-A 324 of the VHT portion 312 of the mixed format preamble 300 may include information intended for multiple non-legacy receivers, whereas VHT-SIG-B 327 of the VHT portion 312 of the mixed format preamble 300 may include information intended for one non-legacy receiver. For example, the multiple non-legacy receivers may acquire control information intended for the multiple non-legacy receivers from VHT-SIG-A 324, such as a group identity (ID). However, one non-legacy receiver may acquire information intended to the non-legacy receiver such as modulation and coding scheme (MCS) from VHT-SIG-B 327. Thus, the VHT portion 312 of the mixed format preamble 300 may include an Omni portion intended for multiple non-legacy receivers and a multi-user (MU) portion intended for one non-legacy receiver.

[0075] A mixed format preamble 300 is associated with an increased signaling overhead due to the inclusion of the legacy portion 311. An alternative to the signaling overhead of the mixed format preamble 300 is a Greenfield preamble. A Greenfield preamble does not include a legacy portion and instead includes only a VHT portion for use by non-legacy receivers or VHT receivers. Because the Greenfield preamble does not include a legacy portion, additional resources may be allocated to the Greenfield preamble. The additional resources allocated to the Greenfield preamble result in improved channel estimation and time and frequency acquisition, among other benefits. For example, the Greenfield preamble may include STFs and LTFs having longer training symbols than a mixed format preamble without adding additional overhead. Further, the STFs and LTFs of the Greenfield preamble may have longer guard intervals than a counterpart mixed format preamble.

[0076] FIG. 4A shows a Greenfield preamble. The Greenfield preamble 400 comprises a Greenfield (GF) STF (GF-STF) 401, a first GF LTF, referred to herein as GF-LTF1 402, and additional GF LTFs, referred to herein as GF-LTFs 404_{1-N} and collectively referred to hereinafter as GF-LTFs 404, and singularly referred to hereinafter as GF-LTF 404_i.

a single receiver, whereby the preamble is said to be an SU preamble. Accordingly, the Greenfield preamble 400 may be used as the basis for an SU preamble, as described with reference to FIG. 4B.

[0090] FIG. 4B shows an SU preamble in accordance with the Greenfield preamble. The SU preamble 410 comprises STF 411, a first LTF, denoted LTF1 412, a signal (SIG) 413 field, and one or more additional LTFs, denoted as LTF2 414, . . . , LTFN 414_{N-1} and referred to collectively hereinafter as LTFs 414.

[0091] STF 411 of the SU preamble 410 may be the same as GF-STF 401 of the Greenfield preamble 400. Further, LTF1 412 may be the same as GF-LTF1 402, SIG 413 may be the same as GF-SIG-A 403, and LTFs 414 may be the same as GF-LTFs 404 of the Greenfield preamble 400. It is noted that because an SU preamble only needs to signal control information to a single receiver, the signaling of control information may be consolidated in SIG 413 and, thus, there is no need for an additional MU SIG field, such as GF-SIG-B 405 of the Greenfield preamble 400.

[0092] Further, the Greenfield preamble 400 may also be used as the basis for an MU preamble, as described with reference to FIG. 4C. Unlike the SU preamble 410 that is intended for a specific receiver, an MU preamble may include a first portion intended for multiple receivers, referred to herein as an Omni portion, and a second portion intended for a subset of the multiple receivers, referred to herein as an MU portion.

[0093] FIG. 4C shows an MU preamble in accordance with the Greenfield preamble. The MU preamble 420 comprises an Omni portion 421 and an MU portion 425. The Omni portion 421 comprises an STF 422, a first LTF, referred to herein as LTF1 423, and a first SIG field, referred to herein as SIG-A 424. Further, STF 422 may be the same as GF-STF 401 of the Greenfield preamble 400, LTF1 423 may be the same as GF-LTF1 402 of the Greenfield preamble 400, and SIG-A 424 may be the same as GF-SIG-A 403 of the Greenfield preamble 400.

[0094] As described herein, the Omni portion 421 of the MU preamble 420 is intended for multiple receivers and the multiple receivers may receive and utilize the Omni portion 421 of the MU preamble 420 as described herein. For example, the multiple receivers may perform AGC and timing and frequency acquisition based on STF 422 of the Omni portion 421, and channel estimation based on LTF1 423 of the Omni portion 421. Further, the multiple receivers may acquire control information intended for the multiple receivers, such as a group identity (ID), from SIG-A 424 of the Omni portion 421 of the MU preamble 420.

[0095] The MU portion 425 of the MU preamble 420 comprises an additional STF, referred to herein as MU-STF 426, one or more additional LTFs, denoted as LTF2 427₁, . . . , LTFN 427_{N-1}, and referred to collectively herein as LTFs 427, and a second SIG field, referred to herein as SIG-B 428.

[0096] LTFs 427 of the MU portion may be the same as GF-LTFs 404 of the Greenfield preamble 400, and SIG-B 428 may also be the same as GF-SIG-B 405 of the Greenfield preamble 400.

[0097] However, although not included in the Greenfield preamble 400, MU-STF 426 may alternatively be included in the MU preamble 420. MU-STF 426 may comprise short training symbols and may be used for performing finer AGC, and time and frequency acquisition than performed based on STF 422 of the Omni portion 421.

[0098] As described herein, a Greenfield preamble 400 may be used by non-legacy receivers or VHT receivers. Further, a mixed format preamble 300 may be used by both VHT receivers and legacy receivers.

[0099] FIG. 5 shows a method for preamble transmission. In the method 500, a transmitter determines whether to transmit a Greenfield preamble 400 or a mixed format preamble 300 501. If the transmitter determines that a Greenfield preamble 400 is to be transmitted, then the transmitter transmits the Greenfield preamble 400 comprising GF-STF 401, GF-LTF1 402, GF-SIG-A 403, GF-LTFs 404, and GF-SIG-B 405 502. If the transmitter determines that a mixed format preamble 300 is to be transmitted, then the transmitter transmits the legacy portion 311 of the mixed format preamble 300 comprising L-STF 321, L-LTF 322, and L-SIG 323 503. The transmitter also transmits the VHT portion 312 of the mixed format preamble 300 comprising VHT-SIG-A 324, VHT-STF 325, VHT-LTFs 326, and VHT-SIG-B 327 504.

[0100] A receiver may be either a VHT receiver that is capable of processing both a VHT preamble and a mixed format preamble or a legacy receiver that is capable of processing only a mixed format preamble.

[0101] FIG. 6 shows a method for processing a preamble. In the method 600, a receiver receives a preamble 601. The receiver determines the type of SIG field of the preamble 602. If the receiver determines that the SIG field is a GF-SIG-A 403, then the receiver processes the GF-SIG-A 403 603. The receiver also processes GF-SIG-B 405 604. If, on the other hand, the receiver determines that the SIG field is an L-SIG 323, the receiver processes the L-SIG 323 605.

[0102] When referred to hereinafter, a preamble may mean any preamble, such as mixed format preamble 300, Greenfield preamble 400, SU preamble 410, or MU preamble 420. Further, when referred to hereinafter, an STF may mean any STF of any preamble, such as L-STF 321 or VHT-STF 325 of mixed format preamble 300, GF-STF 401 of Greenfield preamble 400, STF 411 of SU preamble 410, or STF 422 or MU-STF 426 of MU preamble 420.

[0103] Additionally, when referred to hereinafter, an LTF may mean any LTF of any preamble, such as L-LTF 322 of mixed format preamble 300, or GF-LTF1 402 of Greenfield preamble 400, LTF1 412 of SU preamble 410, or LTF1 423 of MU preamble 420. Furthermore, when referred to hereinafter a SIG field may mean any SIG field of a preamble, such as L-SIG 323, VHT-SIG-A 324, or VHT-SIG-B 327 of mixed format preamble 300, GF-SIG-A 403 or GF-SIG-B 405 of Greenfield preamble 400, SIG 413 field of SU preamble 410, or SIG-A 424 or SIG-B 428 of MU preamble 420. Additionally, when referred to hereinafter, a receiver may mean a legacy receiver, or a non-legacy or VHT receiver.

[0104] A preamble may include an indication as to whether the preamble is an SU preamble intended for a specific receiver or an MU preamble intended for multiple receivers.

[0105] The SIG field may include one or more bits or a field to indicate whether the preamble is an SU preamble or an MU preamble, and a receiver may determine from the SIG field whether the preamble is an SU preamble or an MU preamble. If the receiver determines that the preamble is an MU preamble, the receiver may obtain control information (for example, group ID or N_{STS}) related to multiple receivers from the SIG field. Further, the receiver may obtain information specific to the receiver (for example, MCS) from a SIG field of an MU portion of the preamble.

[0106] If, on the other hand, the receiver determines that the preamble is an SU preamble, the receiver may obtain control information (for example, MCS or N_{STS}) specific to the receiver from the SIG field.

[0107] In another embodiment, an STF or an LTF of a preamble may be used to indicate whether the preamble is an SU preamble or an MU preamble. A sequence or subcarrier mapping of the STF or LTF may be used to indicate whether the preamble is an SU preamble or an MU preamble. When an STF is used to indicate whether the preamble is an SU preamble or an MU preamble, a receiver may be aware of a first STF sequence or subcarrier mapping used to indicate an SU preamble and a second STF sequence or subcarrier mapping used to indicate an MU preamble. A receiver may receive an STF and may apply frequency domain correlation to the received STF and the first STF sequence, and may also apply frequency domain correlation to the received STF and the second STF sequence, in order to determine whether the preamble is an SU preamble or an MU preamble.

[0108] Similar to determining whether the preamble is an SU preamble or an MU preamble based on the STF, a receiver may determine whether the preamble is an SU preamble or an MU preamble based on an LTF.

[0109] In another embodiment, cyclic redundancy check (CRC) masking of a SIG field may be performed to indicate whether the preamble is an SU preamble or an MU preamble. As may be recognized, error protection for a SIG field may be provided through a CRC having a length of L bits and denoted as $C_{L-1}, C_{L-2}, \dots, C_0$. The CRC may be masked with a sequence $x_{L-1}, x_{L-2}, \dots, x_0$ to indicate whether the preamble is an SU preamble or an MU preamble. For example, if the CRC is masked with sequence $\{0, 0, \dots, 0\}$, then an SU preamble is indicated, whereas if the CRC is masked with sequence $\{1, 1, \dots, 1\}$, then an MU preamble is indicated, and vice-versa. It is noted that CRC masking may be performed by applying a modulo 2 operation to the respective bit positions of the CRC and the sequence.

[0110] A receiver may receive the preamble and calculate L CRC bits based on the SIG field. The receiver may further determine whether the preamble is an SU preamble or an MU preamble by comparing the received CRC bits with the calculated CRC bits. It is noted that the masked CRC may be included in the SIG field or elsewhere in the preamble (for example, in a SERVICE field in IEEE 802.11 communications).

[0111] Further, a CRC mask may only be associated with a particular transmission mode and the presence of the CRC mask may indicate the transmission mode. For example, a CRC mask may only be associated with a 1 MHz transmission mode.

[0112] In a further embodiment, tail bits that terminate a convolutional code for a SIG field may be used to indicate whether a preamble is an MU preamble or an SU preamble. For example, the SIG field may be terminated with the tail bits $[0\ 0\ 0\ 0\ 0]$ to indicate that the preamble is an SU preamble, or the SIG field may be terminated with the tail bits $[1\ 1\ 1\ 1\ 1]$ to indicate that the preamble is an MU preamble. Further, in addition to indicating whether the preamble is an MU preamble or an SU preamble, tail bits may carry additional information bits. For example, two bits of information may be carried by choosing among four different termination sequences (e.g., termination sequences $[0\ 0\ 0\ 0\ 0]$, $[1\ 1\ 1\ 0\ 0]$, $[0\ 0\ 1\ 1\ 1]$ or $[1\ 1\ 1\ 1\ 1]$). In addition, the termination sequences may be chosen to maximize a Hamming distance

between resultant codewords. It is noted that three bits may indicate eight possible termination states, whereas four bits may indicate 16 possible termination states up to a maximum of 6 bits, which may be equivalent to a code that is not terminated.

[0113] A receiver may perform convolutional decoding to decode the SIG field. Further, the convolutional decoding may be performed assuming that the tail bits are either $[0\ 0\ 0\ 0\ 0]$ or $[1\ 1\ 1\ 1\ 1]$. After convolutional decoding is performed, a receiver may utilize a maximum likelihood function to determine whether the tail bits of the SIG field are $[0\ 0\ 0\ 0\ 0]$ or $[1\ 1\ 1\ 1\ 1]$, and thus determine whether the preamble is an MU preamble or an SU preamble. Similarly, when more than one bit of information is indicated using the tail bits, a decoding process may choose the best state to trace back from given possible alternatives. In the example above, a convolution decoder may choose the best metric from the four states of $[0\ 0\ 0\ 0\ 0]$, $[1\ 1\ 1\ 0\ 0]$, $[0\ 0\ 1\ 1\ 1]$, and $[1\ 1\ 1\ 1\ 1]$ in order to perform tracing back. It is noted that if tail biting is utilized in an encoder, an appropriate tail-biting decoder may be required to be used in a decoder.

[0114] In one embodiment, the SIG field of a preamble may include an indication of an operating bandwidth or a mode of operation for preamble transmission or data transmission. For example, the SIG field may indicate whether a 1 MHz bandwidth or a 2 MHz bandwidth or mode of operation is used. A bit in the SIG field may be used to indicate the operating bandwidth or the mode of operation.

[0115] A receiver that is capable of operating in either a first bandwidth or a second bandwidth may determine the bandwidth based on the SIG field and the receiver may appropriately process a remainder of the preamble and subsequent data transmissions based on the determined bandwidth (i.e., the receiver may perform detection, or frequency and time synchronization, among others). For example, in IEEE 802.11 communications, if the SIG field indicates 1 MHz bandwidth on either or both an upper or lower 1 MHz band, a receiver may process a preamble or a data transmission according to the 1 MHz bandwidth on either or both of the upper or the lower 1 MHz bands. Further, subcarrier demapping may be performed according to a 1 MHz location of received preamble or data and the receiver may set a Network Allocation Vector (NAV) for either or both of the upper or the lower 1 MHz bands and may ignore a packet based on configurations.

[0116] Further, a receiver that is only capable of operating in the first bandwidth may determine that the second bandwidth is used and may operate accordingly. For example, the receiver may cease receiving on the second bandwidth in order to conserve battery life.

[0117] In another embodiment, the SIG field of a preamble may include an indication of whether packet aggregation is performed. Packet aggregation may be utilized for reducing signaling overhead when available bandwidths are relatively small. Further, packet aggregation results in gain when a large number of receivers or transmitters are available.

[0118] The SIG field may include an indication that a preamble or a data transmission is aggregated, an indication that an aggregated preamble or an aggregated data transmission is intended for one or more specific receivers or multiple receivers, or information for processing or de-aggregation of data transmissions, such as an order of receivers or timing information.

[0119] Aggregation may be performed over contiguous or non-contiguous bandwidths. Further, the contiguous or non-contiguous bandwidths may have the same or different bandwidths. For example, any 5, 10, 40, or 80 MHz bandwidth may be aggregated with any other 5, 10, 40, or 80 MHz bandwidth.

[0120] In one embodiment, the SIG field of a preamble may indicate MCS information for a subchannel (i.e., on a subchannel basis). The MCS information may include the modulation or coding utilized for each subchannel within a transmission bandwidth. For example, the MCS information may indicate a modulation, a coding rate, or a binary convolutional code (BCC) or a low density parity check (LDPC) coding indicator. A receiver may receive MCS information for each subchannel and may demodulate or decode a transmission over each subchannel based on the MCS information.

[0121] It is noted that subchannels in a transmission bandwidth or channel width may be non-contiguous or contiguous. Further, multiple contiguous or non-contiguous subchannels may be used simultaneously for wide-bandwidth transmission or multichannel transmission. Further, each of the subchannels may have its own MCS that is indicated using the SIG field.

[0122] For example, in a transmission bandwidth or channel width of 8 MHz, a subchannel may have a width of less than 8 MHz. Channel conditions, such as interference, of a first subchannel may be different than the channel conditions of a second subchannel. Further, when the channels are non-contiguous, the difference between the channel conditions of the first subchannel and the second subchannel is expected to be larger than when the first subchannel and the second subchannel are contiguous. A subchannel-specific MCS may take into account signal-to-noise ratio (SNR) or bit error rate (BER) conditions for the subchannel or other subchannels.

[0123] In one embodiment, the SIG of an Omni portion of a preamble (for example, GF-SIG-A 403 of Greenfield preamble 400, or SIG-A 424 of MU preamble 420) may include MCS information on a subchannel basis that is intended for multiple users (for example, a BCC or LDPC coding indicator for multiple users). However, the SIG field of an MU portion of the preamble (for example, GF-SIG-B 405 of Greenfield preamble 400, or SIG-A 428 of MU preamble 420) may include MCS information on a subchannel basis intended for a subset of users (for example, a modulation and coding rate for a specific user).

[0124] In an embodiment, a SIG field of a preamble may include an indication of transmit power control information. Further, a receiver may adjust its transmission power according to the power control information included in the SIG field. The SIG field may indicate a power up command indicating that a transmission power should be increased, a power down command indicating that a transmission power should be decreased, or an absolute power level indicating that a transmission power of the receiver should be adjusted to match the absolute power level.

[0125] Additionally, a SIG field of an Omni portion of a preamble (for example, SIG-A 424 of MU preamble 420 or GF-SIG-A 403 of Greenfield preamble 400) may include a reference transmission power level intended for multiple receivers, whereas a SIG field of an MU portion of a preamble (for example, SIG-B 428 of MU preamble 420 or GF-SIG-B 405 of Greenfield preamble 400) may include an offset transmission power level relative to the reference transmission power level. The offset transmission power level may be

intended for one or more specific receivers of the MU portion of the preamble and the specific receiver may adjust its transmission power level to match a power level that is the aggregate of both the reference transmission power level and the offset transmission power level.

[0126] Transmit power control information may include a quantized representation of an absolute power level, a quantized representation of power up or power down indication, a power difference between two measurement intervals for a specific receiver, a power difference between two receivers, or a power difference between a transmitter and a receiver.

[0127] To improve time and frequency acquisition and channel estimation by a receiver, a midamble or a postamble may be utilized in a transmission as described with reference to FIG. 7.

[0128] FIG. 7 shows a transmission including a preamble, midamble, and a postamble. The transmission 700 comprises a preamble 701, where the preamble 701 includes a SIG field 701_A, as described herein. The transmission also includes data fields 702, 704, 706 which may include any data that is intended for a receiver, a first midamble 703, a second midamble 705 (collectively referred to herein as midambles 703, 705), and a postamble 707. The midambles 703, 705 are placed amidst data fields 702, 704, 706 and may comprise STFs or LTFs that may be used by the receiver for time and frequency acquisition, channel estimation, and the like. The midambles 703, 705 may be necessary when the aggregate of the length of data fields 702, 704, 706 is large and the time and frequency acquisition and channel estimation acquired by the receiver based on the preamble 701 have become stale or non-applicable to current communications conditions.

[0129] To achieve diversity, the preamble 701 and the midambles 703, 705 may each use different or orthogonal subcarriers. Further, if available subcarriers are limited, the preamble 701 or the midambles 703, 705 may re-use the subcarriers. Additionally, the preamble 701 and the midambles 703, 705 may be transmitted on different antennas or on orthogonal antennas, or using a spatially orthogonal covering code. Further, each data field 702, 704, 706 may have an MCS associated with the data field 702, 704, 706 and the MCSs may be the same or different for the data fields 702, 704, 706.

[0130] The SIG field 701_A of the preamble 701 may include an indication of the presence of or a location of a midamble (for example, first midamble 703 or second midamble 705) or the postamble 707 in a transmission 700. The location may be indicated by a symbol offset to the midamble, a number of symbols between the midambles 703, 705, time between midambles 703, 705, or an index to a pre-determined midamble location (for example, every nth OFDM symbol). Further, the indication of a location of the midamble may be determined based on an antenna index or an antenna number.

[0131] The SIG field 701_A of the preamble 701 may also include an indication of a format of the midamble, an index to a format of each midamble, or an index to the format of all preambles. The SIG field 701_A of the preamble 701 may also include an indication of a subcarrier pattern of a midamble. Alternatively, a subcarrier pattern may be implicitly indicated using a location of the midamble.

[0132] In an alternative embodiment, midambles 703, 705 may each have a subsequently transmitted midamble SIG (MSIG) field. Each MSIG field of the midambles 703, 705 may indicate the length of subsequent data fields 704, 706, respectively. In addition, the length of data field 702 may be

indicated by the SIG field 701_A of the preamble **701**. Furthermore, SIG field 701_A or an MSIG field associated with midambles **703**, **705** may indicate the MCS associated with data fields **702**, **704**, **706**.

[0133] A receiver may interpolate channel estimates obtained based on preamble **701**, midambles **703**, **705**, or postamble **707**, and may utilize the interpolated channel estimates to process data fields **702**, **704**, **706**. For example, a receiver may interpolate channel estimates obtained based on midambles **703**, **705** and utilize the interpolated channel estimates to process data field **704** that is received between the midambles **703**, **705**. The interpolation may allow for more robust channel estimation.

[0134] Further, a receiver may obtain a Doppler estimate of a channel based on preamble **701**, midambles **703**, **705**, or postamble **707**. The receiver may also request increasing or decreasing the number of midambles based on the Doppler estimate. The Doppler estimate may be sent to a transmitter and may be used to determine whether to increase or decrease the number of midambles sent to the receiver. Doppler estimates may also be used for formation of a group of receivers, whereby the group of receivers may have requested the same number of midambles.

[0135] In another embodiment, the SIG field of a preamble may indicate usage of a short guard interval (GI) for a subsequent data transmission. The SIG field may indicate usage of a short GI using a bit indicator. Additionally, short GI usage may be indicated using a polarity of the pilot tone values of the SIG field. For example, where a SIG field has four pilot tones, pilot tone values [1 1 -1] may indicate the absence of a short GI, whereas pilot tone values [-1 -1 -1 1] may indicate the presence of a short GI.

[0136] A receiver may process the SIG field and may determine the pilot tone values of the SIG field using, for example, a mean squared error (MSE) metric or another metric. The receiver may further determine the presence or absence of a short GI based on the pilot tone values and may process a data transmission accordingly. It is noted that when multiple SIG fields are used to indicate usage of a short GI, the MSE or any other metric may be averaged to increase robustness.

[0137] FIG. 8 shows a preamble indicating a short GI and a data transmission. The preamble **810** comprises an STF **811**, an LTF **812**, and a SIG field **813** which indicates usage of a short GI. Because of the usage of a short GI, the SIG field **813** is followed by a data transmission **820**.

[0138] In an embodiment, the SIG field of a preamble may indicate whether beamforming is utilized on a subsequent data transmission and whether the preamble is a beamforming preamble. Further, when beamforming is utilized, the beamforming preamble may include an additional STF for beamforming, an additional LTF for beamforming, or both an additional STF and an additional LTF for beamforming.

[0139] FIG. 9 shows a beamforming preamble. The beamforming preamble **900** comprises an STF **901**, an LTF **902**, and a SIG field **903**. In addition, the beamforming preamble **900** includes a beamforming STF (BF-STF) **904**, and one or more beamforming LTFs (BF-LTFs), denoted BF-LTF1 **905**, . . . , BF-LTFN **905_N**, and referred to collectively herein as BF-LTFs **905**. BF-STF **904** may be used for AGC correction, whereas BF-LTFs **905** may be used for improved frequency offset and channel estimation by a receiver. The SIG field **903** of the beamforming preamble **900** may include a one-bit indicator for beamforming. It is noted that BT-STF **904** may be replaced by a beamforming LTF, for example,

BF-LTF, and a receiver may perform AGC and time and frequency acquisition based on the BT-LTF.

[0140] In an embodiment, the SIG field of a preamble may include a length field indicating the length of a data transmission in bits, bytes, or OFDM symbols, or in multiples of bits, bytes, or OFDM symbols (for example, in pairs of OFDM symbols). For example, the length field may comprise n bits and may, thus, indicate any length of the data transmission field between 0 and $2^n - 1$ bits, bytes, or OFDM symbols, or multiples of bits, bytes, or OFDM symbols.

[0141] Whether the length field represents the length of the data transmission in bits, bytes, or OFDM symbols, or in multiples of bits, bytes, or OFDM symbols may depend upon the modulation scheme used. Thus, when a first modulation scheme is used, the length field may represent the length of the data transmission in bits, whereas when a second modulation scheme is used, the length field may represent the length of the data transmission in OFDM symbols. Further and by way of example, the SIG field may represent the length of the data transmission in bytes only for modulation scheme MCS0-Rep2 of IEEE 802.11ah, whereas for all other IEEE 802.11ah modulation schemes, the length field may represent the length of the data transmission in OFDM symbols.

[0142] By way of yet another example, the length field of a SIG field may denote the length of a data transmission in OFDM symbols, whereby a length field of a SERVICE field of an IEEE 802.11 data transmission may indicate the length in bytes of the last OFDM symbol of the data transmission.

[0143] Whether the length field represents a length of transmission in bits or bytes may depend on an aggregation indication. For example, when the SIG field indicates that aggregation is not performed, then the length field indicates the length of the data transmission field in bytes, whereas when the SIG field indicates that aggregation is performed, then the length field indicates the length of the data transmission field in OFDM symbols. Further, in IEEE 802.11 it may be required that an aggregated medium access control (MAC) protocol data unit (AMPDU) be used when a data transmission exceeds 2047 bytes in length.

[0144] In order to allocate additional bits in the SIG field for a length field, space time block coding (STBC), which is typically indicated by one or two bits in the SIG field, may be implicitly indicated and the one or two bits used to indicate STBC may be used instead as additional bits for the length field. Furthermore, to allocate additional bits to the length field, short GI indication, aggregation indication, and N_{STS} indication, which are typically indicated using bits of the SIG field, may instead be implicitly indicated and the bits that were formerly used to indicate a short GI, aggregation, and N_{STS} may be used as additional bits for a length field. The modulation scheme of symbols of the SIG field may indicate a short GI, aggregation, and N_{STS} . For example, the modulation scheme of the first symbol of the SIG field may indicate whether STBC is performed, the modulation scheme of the second symbol of the SIG field may indicate whether a short GI is used, the modulation scheme of the third symbol of the SIG field may indicate whether aggregation is performed, and the modulation scheme of the fourth and fifth symbols of the SIG field may indicate N_{STS} .

[0145] In one embodiment, a preamble may be transmitted stand-alone without a subsequent data transmission in order to perform channel sounding. A SIG field of the preamble may indicate that the preamble is used for the purpose of channel sounding. The SIG field may indicate that the pre-

amble is used for the purpose of channel sounding if the length field of the SIG field is set to zero.

[0146] In one embodiment, an STF may use every other available frequency bin in any mode of operation, such as a 1 MHz mode of operation. For example, when using every other available frequency bin, the STF may use twelve tones out of a total of twenty four tones. By using every other tone, the twelve tones of the STF may be $[-12 -10 -8 -6 -4 -2 2 4 6 8 10 12]$. Further, the values of the twelve tones may be $[-1 -1 1 1 1 1 -1 -1 -1 -1 1 1] \cdot (1+i)$.

[0147] Using a fast Fourier transform (FFT) of size 32, the 12-tone STF has a peak-to-average power ratio (PAPR) of 2.06 decibels (dB). Further, the number of repetitions per OFDM symbol for the 12-tone STF is two and the 12-tone STF results in improved autocorrelation properties and improved packet timing detection.

[0148] In another embodiment, an STF may use every fourth available frequency bin in addition to the direct current (DC) bin in any mode of operation, such as a 1 MHz mode of operation. For example, when using every fourth available frequency bin in addition to DC bin, the STF may use seven tones out of a total of twenty four tones. The tones may be $[-12 -8 -4 0 4 8 12]$. Further, the values of the tones may be $[-1 -1 -1 1 1 -1 1] \cdot (1+i)$.

[0149] Using a fast Fourier transform (FFT) of size 32, the STF has a PAPR of 1.32 dB. Further, the number of repetitions per OFDM symbol for the STF is four. The STF has improved autocorrelation properties and improved packet timing detection.

[0150] A preamble may be constructed using 12-tone STFs enabling robust detection, frequency and time synchronization, and channel estimation as described with reference to FIG. 10A. In the preamble of FIG. 10A, a maximum range of frequency offset estimated may be $\pm \Delta f$, where Δf is frequency spacing.

[0151] FIG. 10A shows a preamble having four 12-tone STFs and four LTFs. The preamble 1000 comprises STFs 1001₁₋₄ and LTFs 1002₁₋₄. The STFs 1001₁₋₄ are each 12-tone STFs and have a duration of 40 μ s. The LTFs 1002₁₋₄ are each 26-tone LTFs and have a duration of 40 μ s.

[0152] In addition, a preamble may be constructed using 12-tone STFs and 6-tone STFs enabling robust detection, frequency and time synchronization and channel estimation as described with reference to FIG. 10B. The preamble of FIG. 10B enables estimation of frequency offsets of up to $\pm 2 \Delta f$.

[0153] FIG. 10B shows a preamble having two 12-tone STFs, two 6-tone STFs and two LTFs. The preamble 1010 comprises STFs 1011₁₋₂, STFs 1012₁₋₂ and LTFs 1013₁₋₂. STFs 1011₁₋₂ are each 6-tone STFs and have a duration of 40 μ s. STFs 1011₁₋₂ may be used for AGC, frequency offset estimation, and coarse timing. STFs 1012₁₋₂ are each 12-tone STFs and have a duration of 40 μ s. STFs 1012₁₋₂ may be used for fine frequency offset estimation, fine timing estimation, and channel estimation. LTFs 1013₁₋₂ are each 26-tone LTFs and have a duration of 40 μ s. LTFs 1013₁₋₂ may be used for channel estimation.

[0154] In an embodiment, the transmission of a SIG field or data may be repeated in order to achieve coding and diversity gain. Repetition may be performed on a block-by-block basis (i.e., block-wise) or on a bit-by-bit basis (i.e., bit-wise). Additionally, the data or the SIG field may be scrambled, error encoded, interleaved, and mapped to a modulation scheme before transmission.

[0155] To increase coding and diversity gain, bit-wise repetition may be performed after error correction encoding and before interleaving as described with reference to FIG. 11A.

[0156] FIG. 11A shows an example of bit-wise repetition performed after forward error correction (FEC) encoding. In FIG. 11A, a SIG field or data is scrambled by a scrambler 1101 and FEC encoded by FEC encoder 1102. Bit-wise repetition 1103 is then performed on the output of FEC encoder 1102. After bit-wise repetition 1103, an interleaver 1104 is applied. The interleaver 1104 may have any number of columns (for example, eight columns). After interleaving, a mapper 1105 for any modulation scheme, such as BPSK, is applied and modulated data may be transmitted.

[0157] In an alternative embodiment, bit-wise repetition may be performed before FEC encoding. FIG. 11B shows bit-wise repetition performed before FEC encoding.

[0158] In another alternative embodiment, bit-wise repetition may be performed before FEC encoding and repeated bits may be separately FEC encoded and interleaved, as described with reference to FIG. 11C.

[0159] FIG. 11C shows bit-wise repetition performed before FEC encoding. In FIG. 11C, a SIG field or data is scrambled by a scrambler 1101 and bit-wise repetition 1103 is then performed on the output of the scrambler 1101. The output of bit-wise repetition 1103 is then separately FEC encoded and interleaved, whereby FEC encoder 1103₁ and interleaver 1104₁ are applied to a first output of the bit-wise repeater 1102, and FEC encoder 1103₂ and interleaver 1104₂ are applied to a second output of the bit-wise repeater 1102. Mapper 1105 is then applied to the output of both interleaver 1104₁ and interleaver 1104₂, and modulated data may be transmitted.

[0160] In another embodiment, block-wise repetition may be performed in place of bit-wise repetition. Block-wise repetition may be performed after FEC encoding, as described with reference to FIG. 12.

[0161] FIG. 12 shows an example of block-wise repetition performed after FEC encoding. In FIG. 12, a scrambler 1201 is applied to a SIG field or data. The output of the scrambler 1201 is then FEC encoded by FEC encoder 1202. The output of FEC encoder 1202 is then separately block-wise encoded and interleaved, whereby block-wise encoder 1203₁ and interleaver 1204₁ are applied to a first output of the FEC encoder 1202, and block-wise encoder 1203₂ and interleaver 1204₂ are applied to a second output of the FEC encoder 1202. The outputs of interleavers 1204₁ and 1204₂ are then combined and provided to mapper 1205 for modulation mapping, and mapped data may be transmitted.

[0162] The use of repetition may be implicitly indicated when bandwidth selection is indicated. For example, if a 1 MHz or a 2 MHz bandwidth is indicated, then the use of repetition is implicitly indicated, and vice-versa. Further, in IEEE 802.11 communication, the use of repetition may be indicated by an RXVECTOR. An RXVECTOR may have a list of parameters that a physical layer (PHY) provides to a local MAC entity. For example, the RXVECTOR may indicate the use of either one of a 1, 2, 4, or 8 MHz bandwidth, or the use of one of a 2, 4, 8, or 16 MHz bandwidth. Further, repetition may be used only when the RXVECTOR indicates the use of either one of a 1, 2, 4, or 8 MHz bandwidth.

[0163] In another embodiment, transmit antenna diversity with cyclic shifting may be employed for transmitting a SIG field or data to increase frequency diversity, as described with reference to FIG. 13. Further, to achieve repetition gain, the

SIG field or data may be bit-wise or block-wise repeated, as described with reference to FIGS. 11A-C and 12, prior to being transmitted using antenna diversity and cyclic shifting. [0164] FIG. 13 shows transmission of a SIG field or data using antenna diversity and cyclic shifts. A SIG field or data that is an output of FIGS. 11A-C or 12 (i.e., a SIG field or data that is scrambled, FEC-encoded, repeated, interleaved, or mapped to a modulation scheme) is provided to an IFFT 1301. The output of the IFFT 1301 is provided to each of four paths. In a first path, a short GI 1303 is inserted, in a second path a first cyclic shift 1302₁ and a short GI 1303 are inserted, in a third path a second cyclic shift 1302₂ and a short GI 1303 are inserted, and in a fourth path a third cyclic shift 1302₃ and a short GI 1303 are inserted. After cyclic shift and short GI insertion, data is transmitted using antennas 1304 for each path. It is noted that repetition and frequency diversity gain are achieved because each path receives from the IFFT 1301 a SIG field, a repeated SIG field, or a combination of a SIG field and a repeated SIG field.

[0165] In an embodiment, a power headroom report may be requested from a receiver, for example, using a power headroom request, and a power headroom report may be provided by a receiver. If there are multiple receivers in a serving area, a power headroom request may be sent to the multiple receivers, for example, using a power headroom poll.

[0166] A power headroom response may be transmitted using round robin reports or simultaneous reporting using orthogonal reporting, such as orthogonal data signatures. Further, a received signal strength indication (RSSI) or a received channel power indication (RCPI) may be measured based on a preamble or a data transmission, and if the RSSI or RCPI changes from a previous measurement, a correction in transmit power may be determined taking into account the power headroom of multiple receivers.

[0167] A CRC code for a SIG field of a preamble may be punctured in order to reduce a number of parity bits. By optimally puncturing a CRC code, a shorter code may be generated. For example, an 8-bit CRC code may be punctured to generate a 4-bit CRC code.

[0168] In an example, an 8-bit CRC may be generated using the polynomial $x^8+x^7+x^6+x^5+1$ for a 26-bit SIG field. A resultant parity check matrix for the CRC code may be described as $H=[P I_8]$, where P is an 8x26 matrix and I_8 is an 8x8 identity matrix. In order to reduce the number of parity bits from 8 to 4, 4 rows may be removed from matrix P to get a 4x26 matrix denoted as P1. A new parity check matrix may be used, where the parity check matrix is $H1=[P1 I_4]$, P1 is a 4x26 matrix, and I_4 is a 4x4 identity matrix.

[0169] In order to avoid a minimum Hamming distance of 1, a requirement may be imposed that no column of the parity check matrix may be composed of all zeros. Therefore, when 4 rows are removed in the example above, it is desirable for the matrix P1 not to have an all-zero column.

[0170] The Hamming Weight (HW) distribution of a code may be derived from the parity check matrix as follows: the number of codewords with HW=i is the number of combinations of i columns of the parity check matrix, such that a linear combination is equal to a zero vector.

[0171] For an 8-bit code, there are 70 combinations of 4-bit puncturing patterns, (i.e., there are 70 ways to puncture an 8-bit code to a 4-bit code). Table 3 shows a HW distribution for 26 information bits when a 4-bit CRC is derived by puncturing from an 8-bit CRC. Table 4, on the other hand, shows a HW distribution for 38 information bits when a 4-bit CRC

is derived by puncturing from an 8-bit CRC. In Tables 3 and 4, the HW distribution is shown for HW=1, 2, 3, 4, and 5. Additionally, c_0 represents the most significant bit (MSB) that is punctured and c_7 represents the least significant bit (LSB) that is punctured.

CRC bits	HW = 1	HW = 2	HW = 3	HW = 4	HW = 5
$C_7C_6C_5C_4$ (LSBs)	3	28	254	1663	8839
$C_3C_2C_1C_0$ (MSBs)	2	24	247	1687	8969
$C_5C_2C_1C_0$	0	31	247	1658	9029
$C_5C_3C_2C_0$	0	34	247	1635	9029
$C_5C_4C_1C_0$	0	27	265	1670	8879
$C_5C_4C_2C_0$	0	31	252	1657	8976
$C_5C_4C_3C_1$	0	29	264	1658	8890
$C_6C_3C_1C_0$	0	35	246	1648	8992
$C_6C_2C_2C_1$	0	29	260	1662	8930
$C_6C_4C_3C_1$	0	31	263	1646	8901
$C_6C_5C_2C_0$	0	33	259	1640	8909
$C_6C_5C_3C_2$	0	32	259	1645	8925
$C_7C_4C_2C_1$	0	33	248	1646	9018
$C_7C_4C_3C_0$	0	29	264	1658	8890
$C_7C_4C_3C_1$	0	29	260	1662	8930
$C_7C_5C_2C_0$	0	34	255	1635	8949
$C_7C_5C_4C_1$	0	32	266	1629	8874
$C_7C_6C_3C_2$	0	29	262	1674	8896

[0172] Table 3 shows a HW distribution when a 4-bit CRC is derived from an 8-bit CRC for 26 information bits.

CRC Bits	HW = 1	HW = 2	HW = 3	HW = 4	HW = 5
$C_7C_6C_5C_4$ (LSBs)	3	52	707	6932	53267
$C_3C_2C_1C_0$ (MSBs)	3	51	697	6947	53377
$C_5C_3C_2C_0$	0	65	692	6867	53564
$C_5C_4C_2C_0$	0	58	711	6942	53325
$C_6C_4C_3C_1$	0	56	720	6938	53292
$C_6C_5C_2C_0$	0	62	704	6894	53426
$C_6C_5C_3C_2$	0	58	717	6906	53339
$C_7C_4C_2C_1$	0	65	699	6865	53501
$C_7C_5C_4C_1$	0	60	721	6876	53323

[0173] Table 4 shows a HW distribution when a 4-bit CRC is derived from an 8-bit CRC for 38 information bits.

[0174] As shown in Tables 3 and 4, puncturing bits $c_7c_6c_5c_4$ (i.e., the four LSBs) or bits $c_3c_2c_1c_0$ (i.e., the four MSBs) does not yield results as good as other alternatives, such as puncturing bits $c_5c_4c_2c_0$, since both $c_7c_6c_5c_4$ and $c_3c_2c_1c_0$ have a minimum hamming distance of 1. Further, any of the puncturing combinations in Tables 3 and 4 may be chosen for a code with a minimum distance 2 to detect all single bit-error patterns.

[0175] It is worth noting that a puncturing combination such as bits $c_5c_4c_1c_0$ shown in Table 3 yields a probability of false positives that is close to that of an optimal 4-bit CRC generated using the polynomial x^4+x+1 .

[0176] In an embodiment, the type of modulation used for SIG field symbols may be used to signal information, such as information as to whether beamforming is utilized, for example, a SIG field may comprise any number of OFDM symbols, such as 5 OFDM symbols or 6 OFDM symbols. Further, the 6 OFDM symbols may be modulated using quadrature binary phase shift keying (QBPSSK) or binary

phase shift keying (BPSK). It is worth noting that according to QPSK, a symbol is modulated using $+/-j$, whereas according to BPSK, a symbol is modulated using $+/-1$.

[0177] The modulation scheme of any one of the OFDM symbols may be used to signal information. For example, the modulation scheme of the first OFDM symbol may be used to signal that beamforming is utilized, whereby if the first OFDM symbol is modulation using BPSK, then the use of beamforming is not indicated, whereas if the first OFDM symbol is modulation using QPSK, then the use of beamforming is indicated.

[0178] Further, the modulation scheme of the OFDM symbols of the SIG field may be used in conjunction with a CRC attachment or FEC encoding to increase the number of information bits signaled using the SIG field.

[0179] FIG. 14A shows an example of coding of SIG field bits. In FIG. 14A, X bits of a SIG field are provided to a CRC attachment unit 1401. The CRC attachment unit 1401 generates A CRC bits. The X+A SIG field bits and CRC attachment bits are provided to an FEC encoder 1402 to generate an output. The output of the FEC encoder 1402 is then provided to a repeater, interleaver, and mapper unit 1403, and the encoded and modulated X+A field bits and CRC attachment bits may be transmitted.

[0180] The number of bits signaled using the SIG field may be increased from X to X+Y while protecting the additional Y SIG fields using CRC encoding as described with reference to FIG. 14B.

[0181] FIG. 14B shows an example of coding of SIG field bits and additional bits. In FIG. 14B, X SIG field bits and Y additional SIG field bits are provided to a CRC attachment unit 1401. The CRC attachment unit 1401 generates A CRC attachment bits based on both the X SIG field bits and Y additional SIG field bits, and provides an output of X+Y+A bits. The X+A bits pertaining to the SIG field and CRC attachment are provided to an FEC encoder 1402 to generate an output. The output of the FEC encoder 1402 is provided to a repeater, interleaver, and mapper unit 1403 in the same manner as described with reference to FIG. 14A.

[0182] However, the Y additional bits may not be transmitted in the same manner as the X+A bits pertaining to the SIG field and CRC attachment. Instead, the Y additional bits may be provided to a SIG symbol modulation unit 1404, which modulates the Y bits using the SIG field OFDM symbols as described above. For example, if the Y bits are [0 0 1 1 1], then five SIG field OFDM symbols may be modulated as [QBBBB] to indicate the Y bits, where a QPSK modulation of a SIG field symbol indicates a zero bit and a BPSK modulation indicates a 1 bit.

[0183] As described with reference to FIG. 14B, the Y additional bits are protected using the A CRC attachment bits. Further, no additional overhead is needed for signaling the Y additional bits. Further, in addition to CRC attachment, the Y additional bits may also be protected by an FEC code, as described with reference to FIG. 14C.

[0184] FIG. 14C shows an example of coding of SIG field bits and additional bits. In FIG. 14C, X SIG field bits and Y additional bits are provided to a CRC attachment unit 1401. The CRC attachment unit 1401 generates A CRC bits and provides an output of X+Y+A bits to the FEC encoder 1402, which generates an output. A first portion of the output of the FEC encoder 1402 is provided to a repeater, interleaver, and mapper unit 1403 and a second portion of the output of the FEC encoder 1402 (for example, 5 or 6 bits) is provided to a

SIG symbol modulation unit 1404, which modulates the Y bits using the SIG field OFDM symbols as described above.

[0185] Further, the modulation scheme of the OFDM symbols of the SIG field may be used to introduce more CRC attachment bits in order to improve the robustness of the CRC attachment. For example, the CRC attachment may be increased from A bits to A+B bits. Further, the additional B CRCs bits may signaled using the modulation of the OFDM symbols. Further, the additional B CRC bits may be further coded using any coding scheme as described with reference to FIG. 14D.

[0186] FIG. 14D shows an example of coding of SIG field bits and additional CRC bits. In FIG. 14D, X SIG field bits are provided to a CRC attachment unit 1401. The CRC attachment unit 1401 generates a CRC attachment of A+B bits (i.e., the CRC attachment unit 1401 generates B additional attachment bits than shown in FIGS. 14A-C). The X SIG field bits and the A CRC attachment bits are provided to FEC encoder 1402 to generate an output. The output of the FEC encoder 1402 is provided to a repeater, interleaver, and mapper unit 1403, and may then be transmitted. On the other hand, the B CRC attachment bits are provided to a (B,Z) encoder 1405. The (B,Z) encoder 1405 encodes the B CRC attachment bits using Z bits, (for example, the (B,Z) encoder may encode B=4 bits using Z=6 bits). The Z bits are provided to a SIG symbol modulation unit 1404 which modulates the Z bits using the SIG field OFDM symbols as described above.

[0187] In an embodiment, a cyclic shift may be applied to Greenfield preamble, such as Greenfield preamble 400. The cyclic shift may prevent unintentional beamforming when identical signals are transmitted on different spatial streams. The cyclic shift may be similar to a cyclic shift used in a subsequent data transmission particularly in the case where the same data transmission is performed over multiple antennas. However, the values of the cyclic shift used in the Greenfield preamble and a subsequent data transmission may be different for different antennas.

[0188] Although features and elements are described above in particular combinations, one of ordinary skill in the art will appreciate that each feature or element can be used alone or in any combination with the other features and elements. In addition, the methods described herein may be implemented in a computer program, software, or firmware incorporated in a computer-readable medium for execution by a computer or processor. Examples of computer-readable media include electronic signals (transmitted over wired or wireless connections) and computer-readable storage media. Examples of computer-readable storage media include, but are not limited to, a read only memory (ROM), a random access memory (RAM), a register, cache memory, semiconductor memory devices, magnetic media such as internal hard disks and removable disks, magneto-optical media, and optical media such as CD-ROM disks, and digital versatile disks (DVDs). A processor in association with software may be used to implement a radio frequency transceiver for use in a WTRU, UE, terminal, base station, RNC, or any host computer.

What is claimed is:

1. A method for receiving a preamble in multi-user (MU) multiple input multiple output (MIMO) communications, the method comprising:

receiving the preamble comprising a short training field (STF), a first long training field (LTF), a first signal

- (SIG) field, at least one additional LTF, and a second SIG field, wherein the preamble is a multi-user (MU) preamble;
 - performing time or frequency acquisition based on the STF;
 - performing channel estimation based on the first LTF;
 - obtaining a first control information from the first SIG field; and
 - obtaining a second control information from the second SIG field, wherein the first control information is associated with multiple receivers and the second control information is associated with a subset of the multiple receivers.
2. The method of claim 1 wherein the first LTF comprises two long training symbols preceded by a double length cyclic prefix.
 3. The method of claim 1 wherein the first SIG field indicates whether the preamble is a single user (SU) preamble or a Multi user (MU) preamble.
 4. The method of claim 1 wherein cyclic redundancy check (CRC) masking of the first SIG field indicates whether the preamble is an SU preamble or an MU preamble.
 5. The method of claim 1 wherein the first SIG field or the second SIG field indicates an operating bandwidth, modulation on a subchannel basis, coding information on a subchannel basis, or whether data transmission is aggregated.
 6. The method of claim 1 wherein the first SIG field indicates a reference transmission power level and the second SIG field indicates an offset transmission power level relative to the reference transmission power level.
 7. The method of claim 1 wherein the first SIG field or the second SIG field includes an indication of a presence of a midamble or an indication of a location of the midamble.
 8. The method of claim 1 wherein the first SIG field or the second SIG field indicates usage of a short guard interval (GI) for a subsequent data transmission or the first SIG field indicates whether beamforming is performed.
 9. The method of claim 1 wherein a modulation scheme indicates whether a length field of the first SIG field indicates length in bits, bytes, or orthogonal frequency division multiplexing (OFDM) symbols, or multiples of bits, bytes, or OFDM symbols.
 10. The method of claim 1 wherein bit-wise repetition is performed on the first SIG field or the second SIG field, and wherein a SIG field and a repeated SIG field are separately forward error correction (FEC) encoded and interleaved prior to modulation.
 11. The method of claim 1 wherein the preamble comprises four 12-tone STFs, and four LTFs or two 12-tone STFs, two 6-tone STFs, and two LTFs.
 12. A wireless transmit/receive unit (WTRU) for receiving a preamble in multi-user (MU) multiple input multiple output (MIMO) communications, the WTRU comprising:

- a receiver configured to receive the preamble, the preamble comprising a short training field (STF), a first long training field (LTF), a first signal (SIG) field, at least one additional LTF, and a second SIG field, wherein the preamble is a multi-user (MU) preamble; and
 - a processor configured to perform time or frequency acquisition based on the STF and channel estimation based on the first LTF, the processor further configured to obtain a first control information from the first SIG field and a second control information from the second SIG field, wherein the first control information is associated with multiple receivers and the second control information is associated with a subset of the multiple receivers.
13. The WTRU of claim 12 wherein the first LTF comprises two long training symbols preceded by a double length cyclic prefix.
 14. The WTRU of claim 12 wherein the first SIG field indicates whether the preamble is a single user (SU) preamble or a Multi user (MU) preamble.
 15. The WTRU of claim 12 wherein cyclic redundancy check (CRC) masking of the first SIG field indicates whether the preamble is an SU preamble or an MU preamble.
 16. The WTRU of claim 12 wherein the first SIG field or the second SIG field indicates an operating bandwidth or whether data transmission is aggregated.
 17. The WTRU of claim 12 wherein the first SIG field indicates a reference transmission power level and the second SIG field indicates an offset transmission power level relative to the reference transmission power level.
 18. The WTRU of claim 12 wherein the first SIG field or the second SIG field includes an indication of the presence of a midamble or an indication of a location of the midamble.
 19. The WTRU of claim 12 wherein the first SIG field or the second SIG field indicates usage of a short guard interval (GI) for a subsequent data transmission or the first SIG field indicates whether beamforming is performed.
 20. The WTRU of claim 12 wherein a modulation scheme indicates whether a length field of the first SIG field indicates length in bits, bytes, or orthogonal frequency division multiplexing (OFDM) symbols, or multiples of bits, bytes, or OFDM symbols.
 21. The WTRU of claim 12 wherein bit-wise repetition is performed on the first SIG field or the second SIG field, and wherein a SIG field and a repeated SIG field are separately forward error correction (FEC) encoded and interleaved prior to modulation.
 22. The WTRU of claim 12 wherein the preamble comprises four 12-tone STFs, and four LTFs, or two 12-tone STFs, two 6-tone STFs, and two LTFs.

* * * * *