



US 20070060946A1

(19) **United States**

(12) **Patent Application Publication**
Keegan et al.

(10) **Pub. No.: US 2007/0060946 A1**

(43) **Pub. Date: Mar. 15, 2007**

(54) **EMBOLIC PROTECTION SYSTEM**

Related U.S. Application Data

(75) Inventors: **Martin Keegan**, Knocknacarra (IE);
Eamon Brady, Elphin (IE); **Brendan Casey**, Barna (IE); **David Vale**,
Clontarf (IE); **John Neilan**, Gort (IE);
Morgan Tierney, Ferbane (IE)

(63) Continuation of application No. 10/379,434, filed on
Mar. 5, 2003, now Pat. No. 7,144,408.

(60) Provisional application No. 60/361,340, filed on Mar.
5, 2002.

Publication Classification

Correspondence Address:
SUGHRUE MION, PLLC
2100 PENNSYLVANIA AVENUE, N.W.
SUITE 800
WASHINGTON, DC 20037 (US)

(51) **Int. Cl.**
A61M 29/00 (2006.01)
(52) **U.S. Cl.** **606/200**

(57) **ABSTRACT**

(73) Assignee: **SALVIAC LIMITED**, Dublin 2 (IE)

An embolic protection filter system comprises a collapsible embolic protection filter **62** having a collapsed configuration for delivery of the filter, and a deployed configuration and a temporary lumen defining member **60**. The lumen defining member **60** is used for loading a filter-containing delivery catheter **63** onto a guidewire **65**. After loading, the member **60** can be removed by pulling on a tab **61**.

(21) Appl. No.: **11/534,004**

(22) Filed: **Sep. 21, 2006**

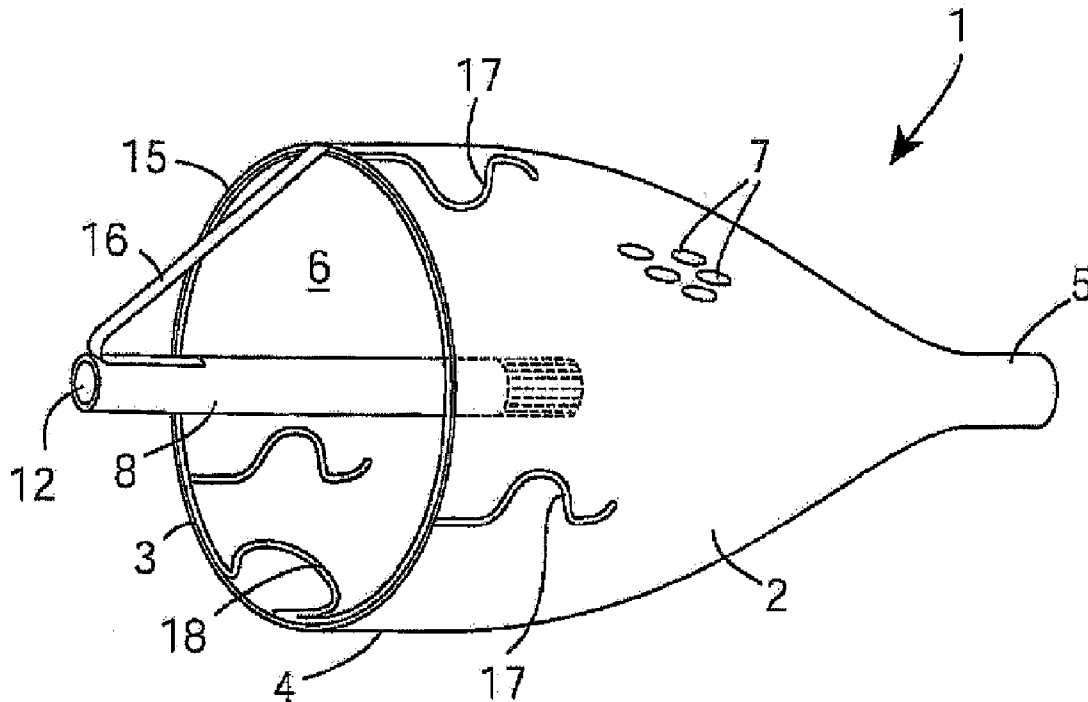

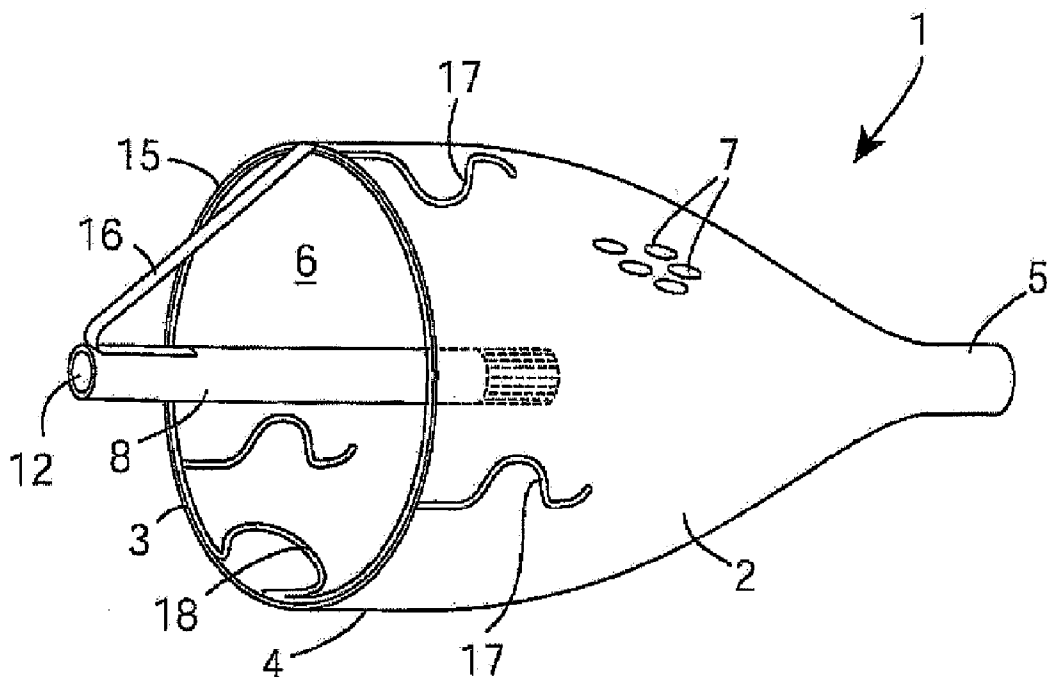

FIG. 1

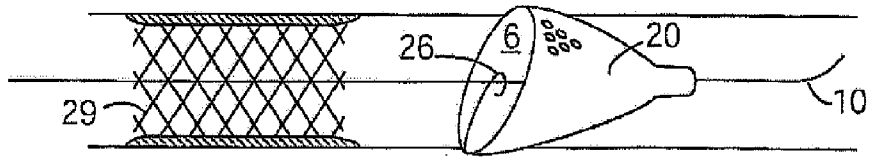
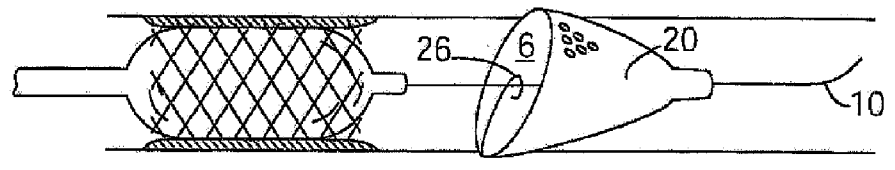
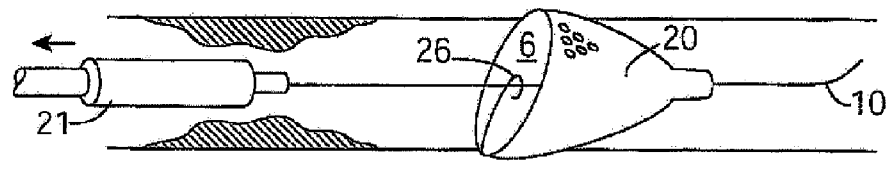
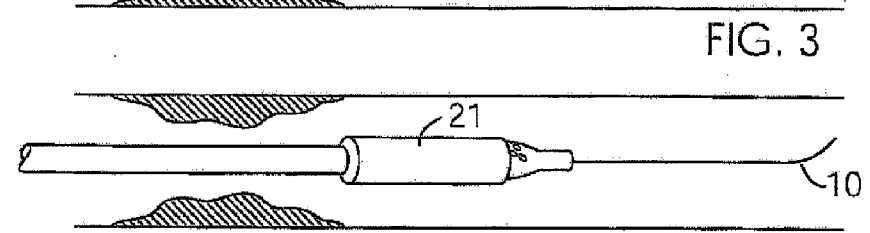
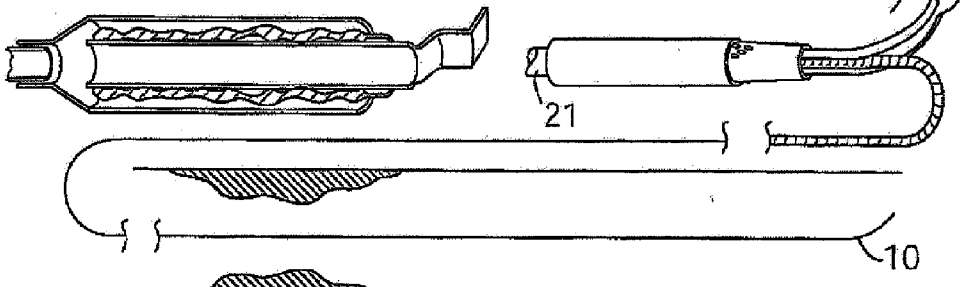
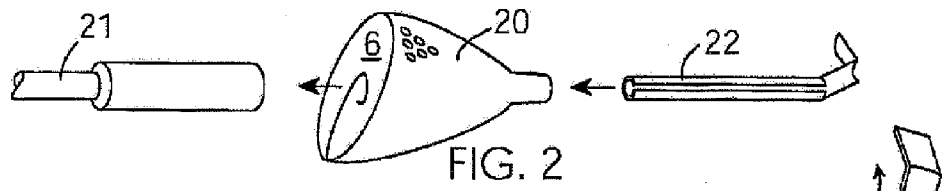

FIG. 7

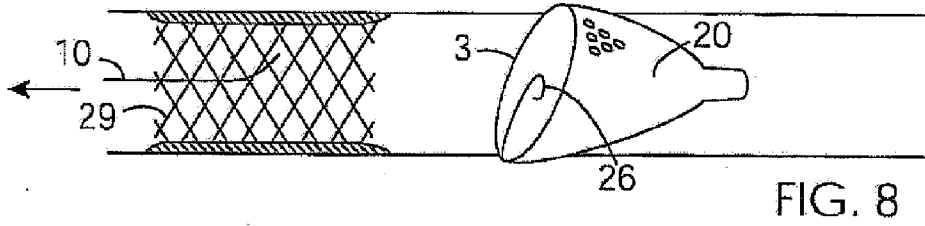

FIG. 8

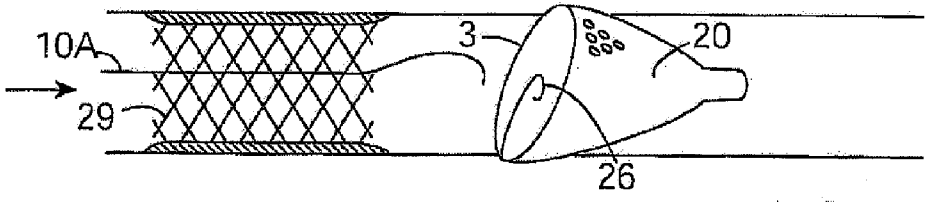

FIG. 9

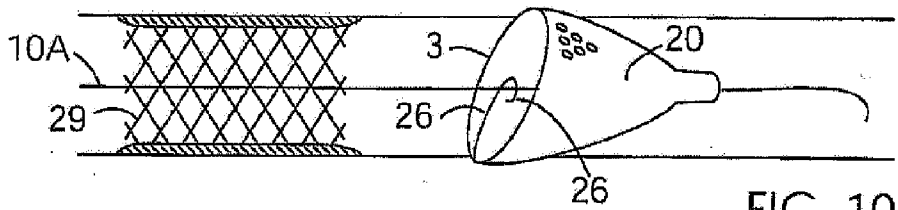

FIG. 10

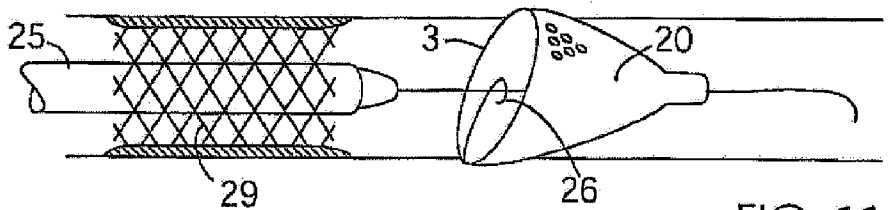

FIG. 11

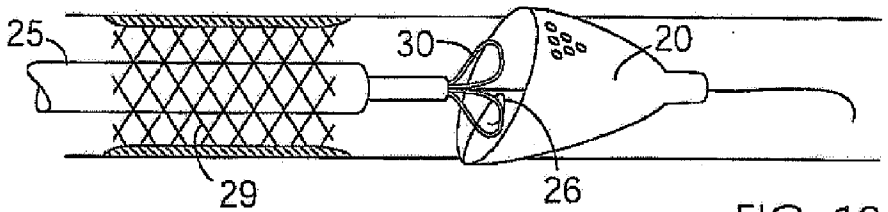

FIG. 12

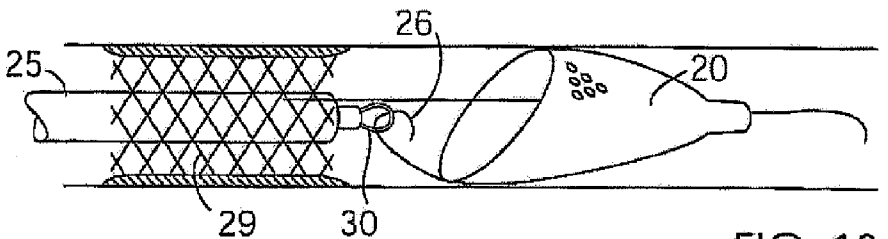

FIG. 13

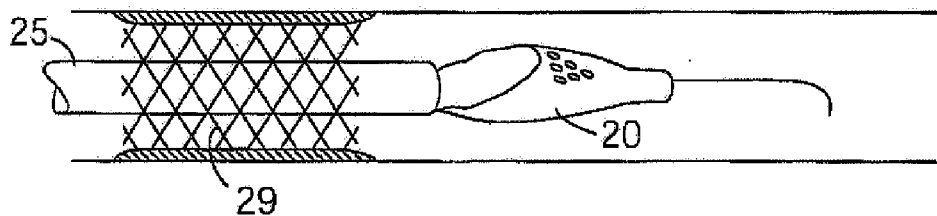

FIG. 14

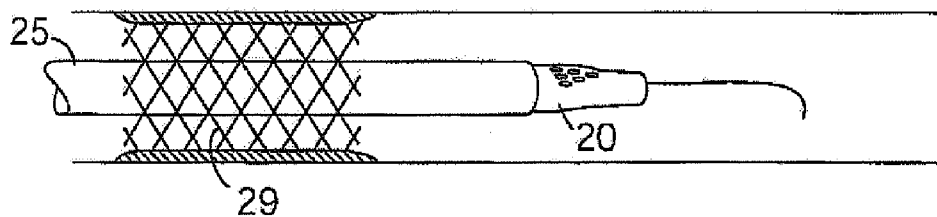

FIG. 15

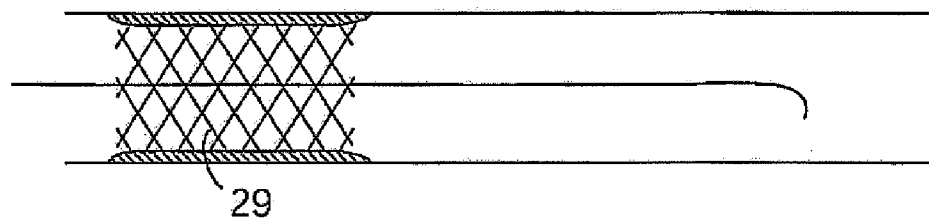

FIG. 16

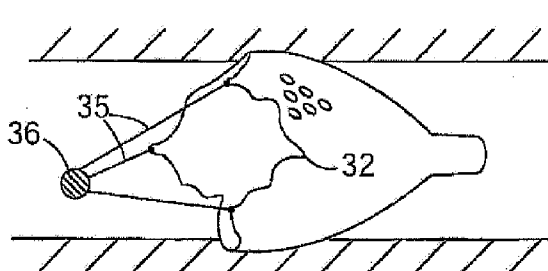
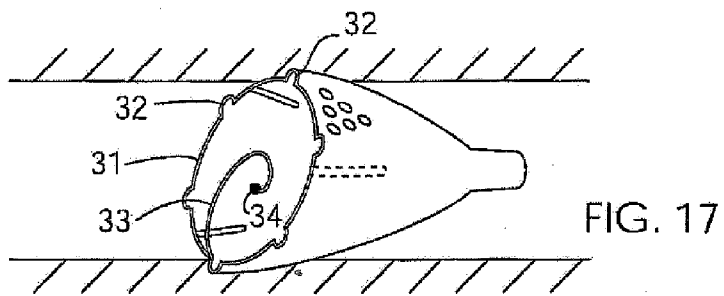

FIG. 18

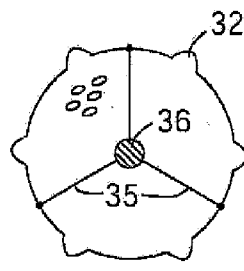

FIG. 19

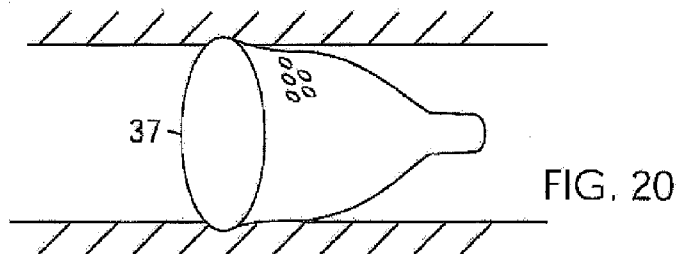

FIG. 20

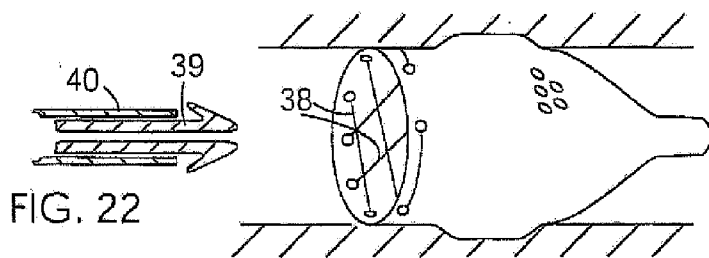

FIG. 22

FIG. 21

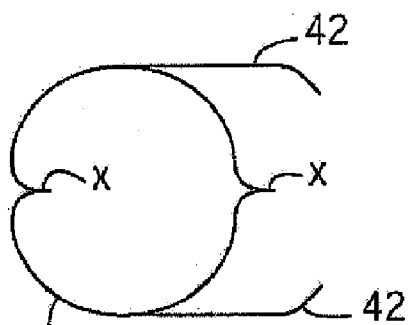

FIG. 23

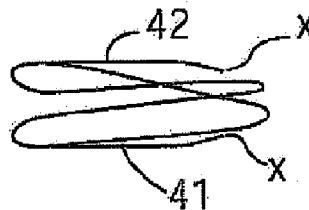

FIG. 24

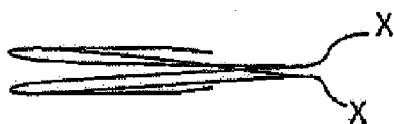

FIG. 25

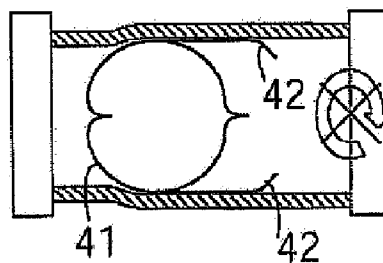

FIG. 26

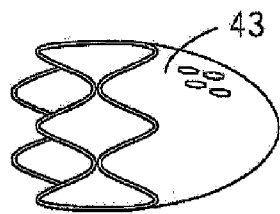

FIG. 27

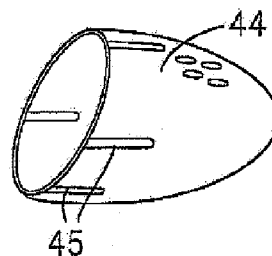

FIG. 28

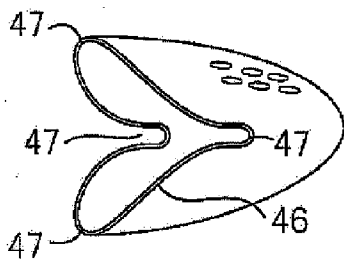

FIG. 29

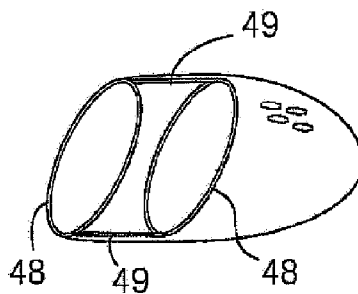

FIG. 30

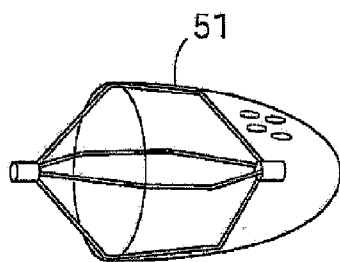
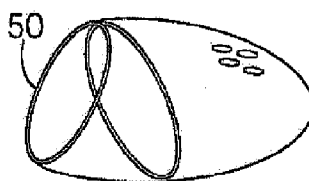

FIG. 31A



50
FIG. 31

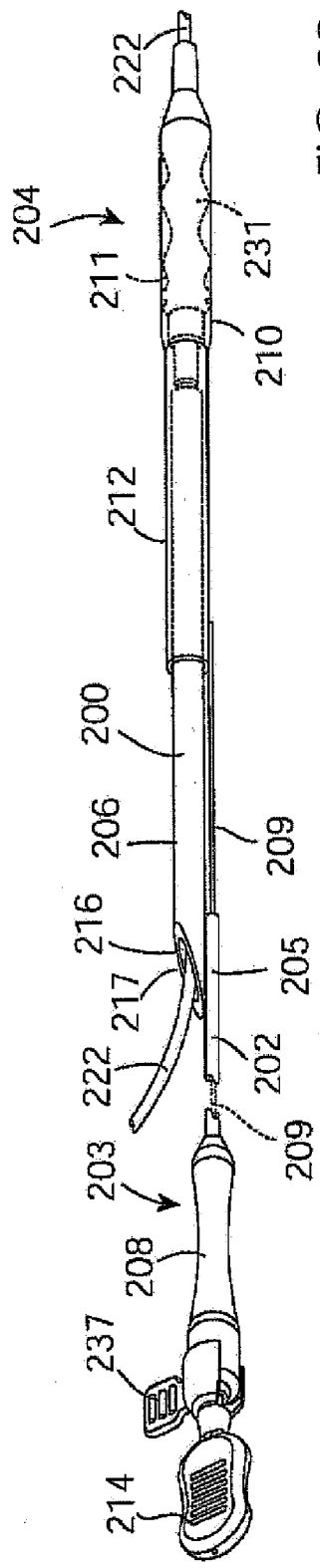

FIG. 32

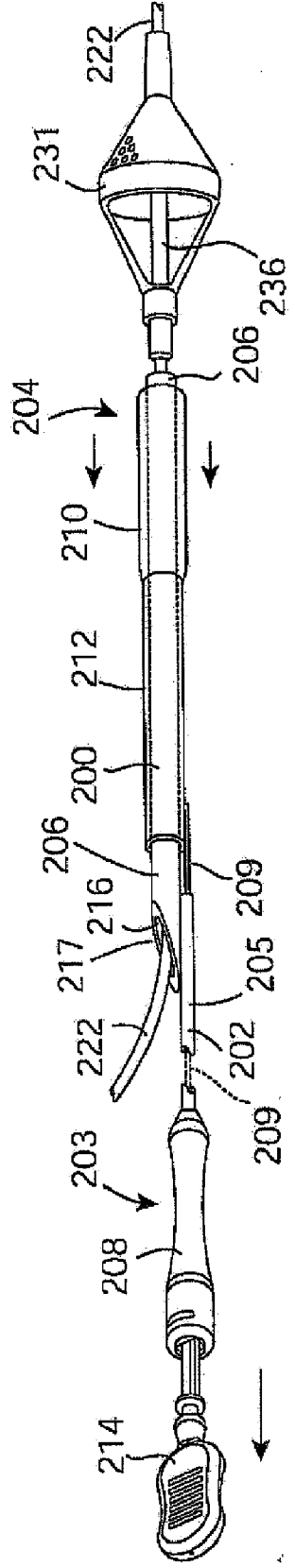

FIG. 33

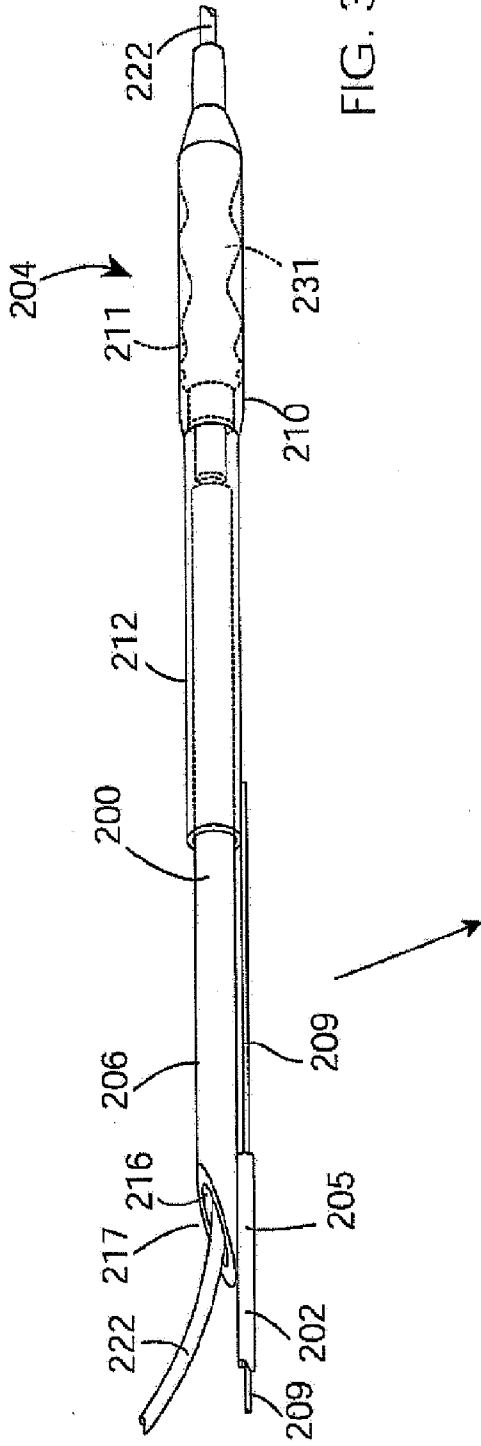

FIG. 34

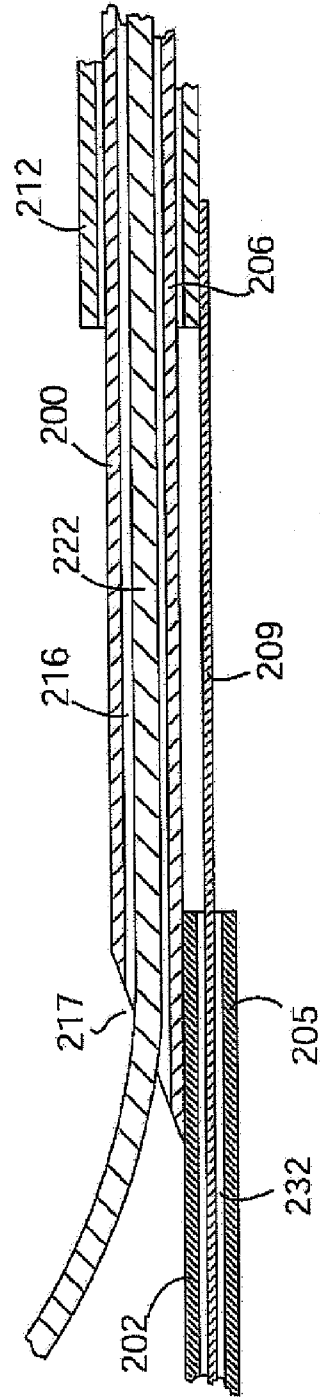

FIG. 35

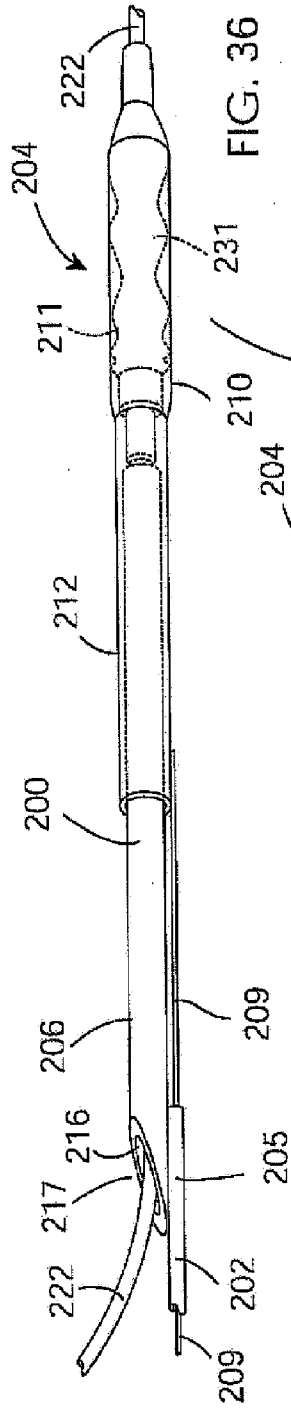

FIG. 36

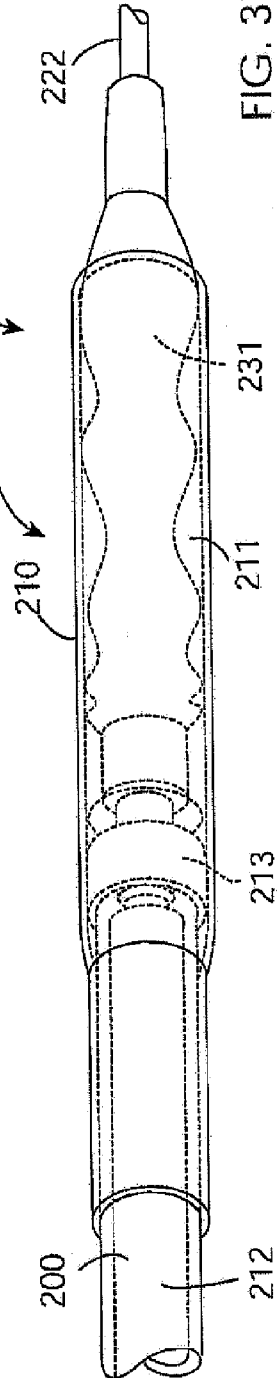

FIG. 37

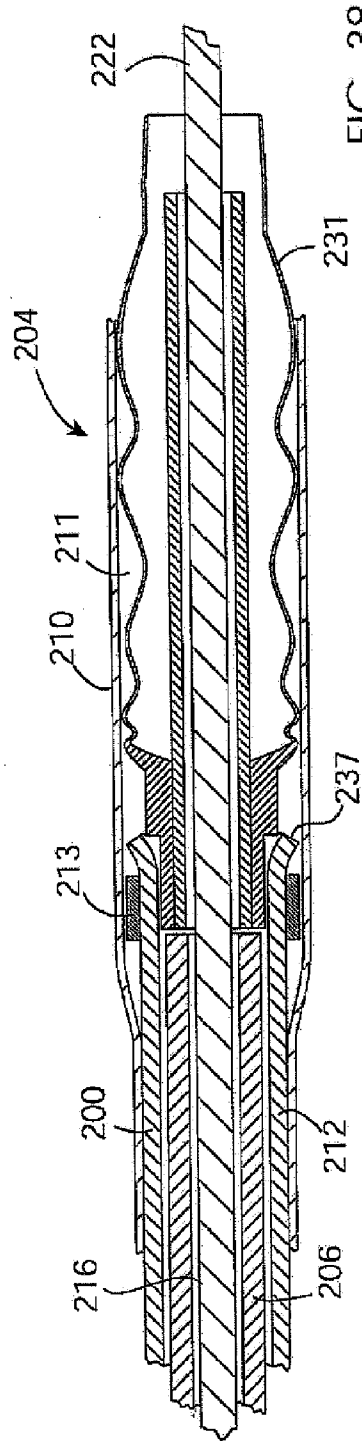

FIG. 38

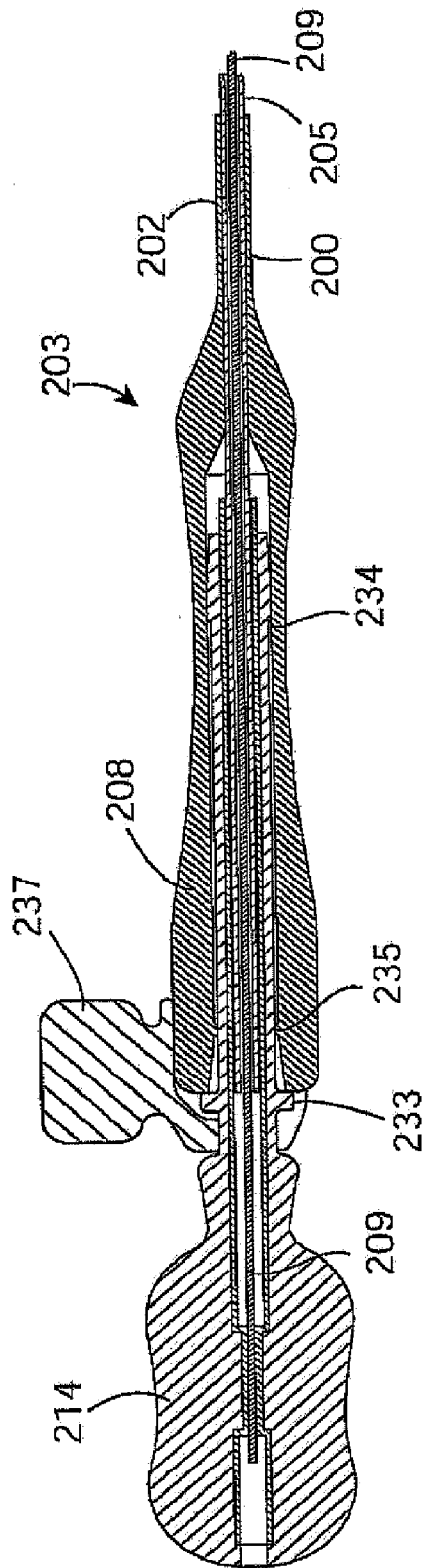

FIG. 39

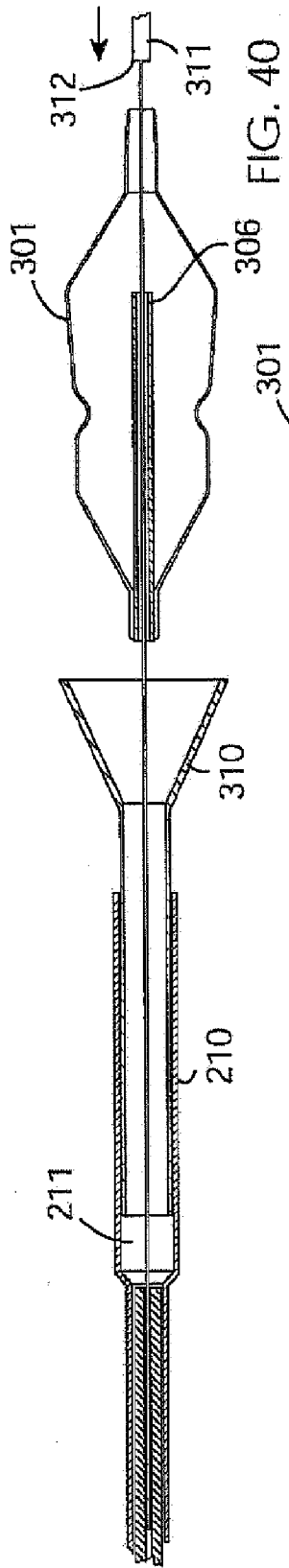

FIG. 40

FIG. 41

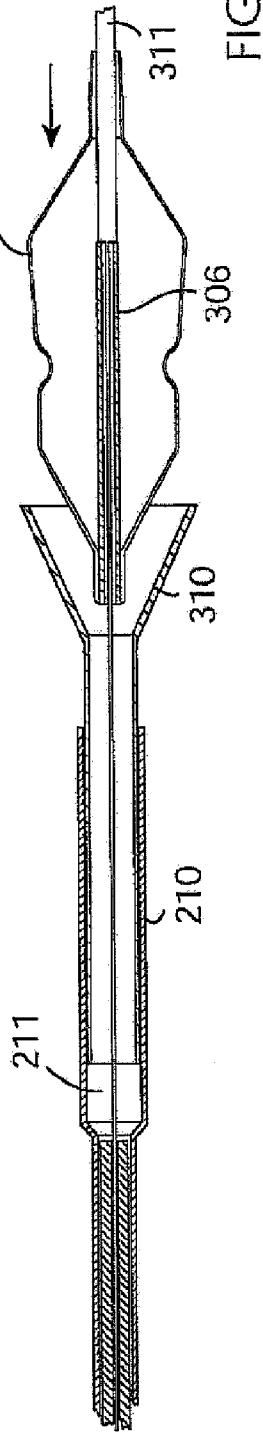

FIG. 42

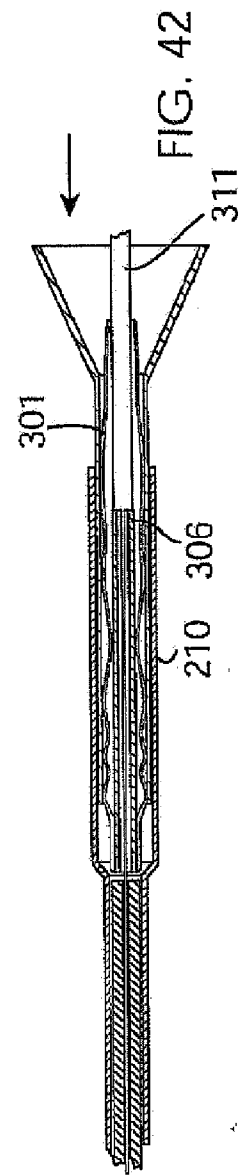

FIG. 43

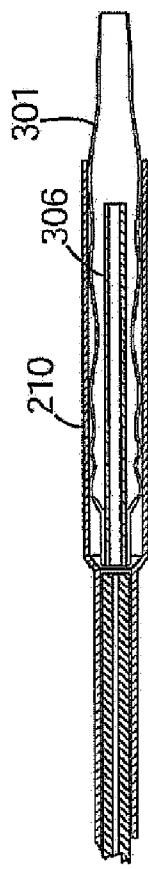
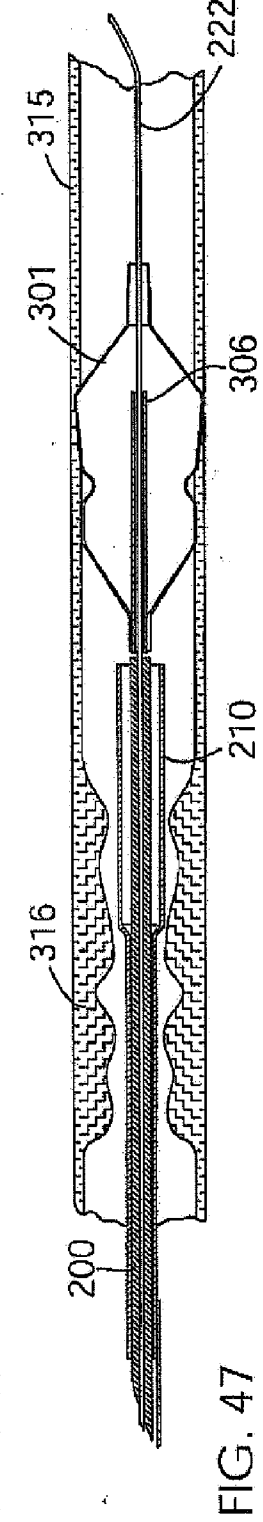
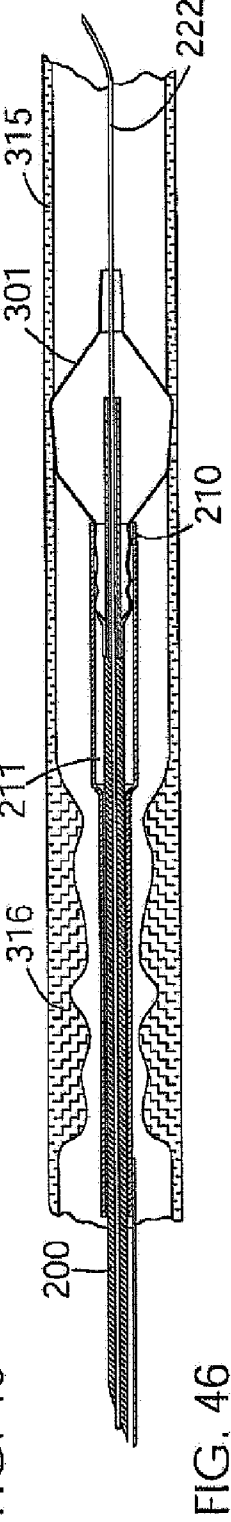
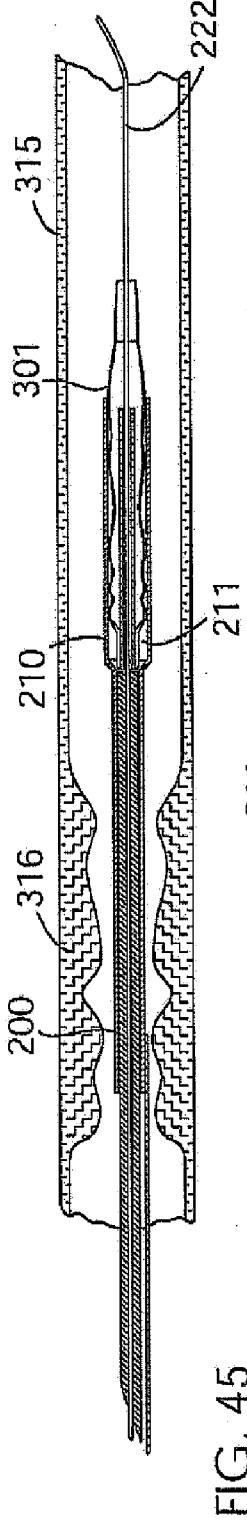
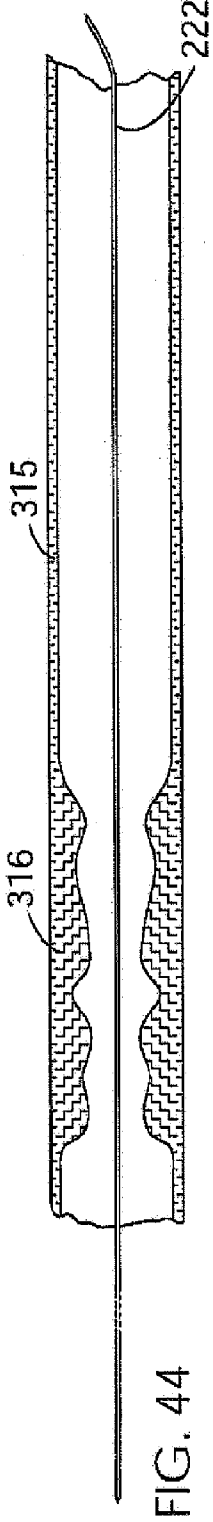

FIG. 43



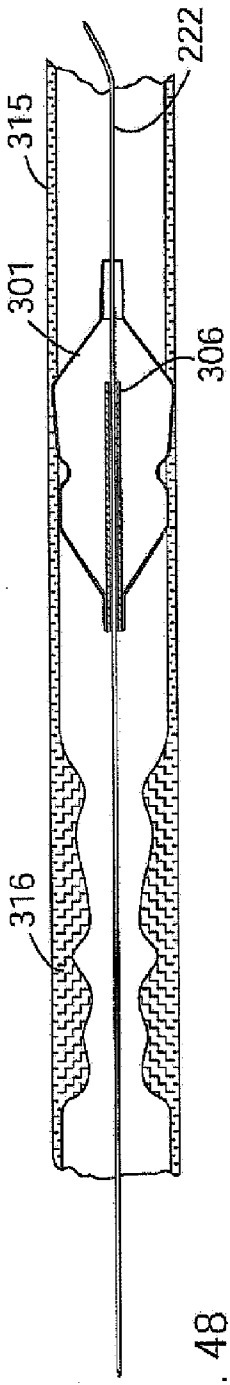

FIG. 48

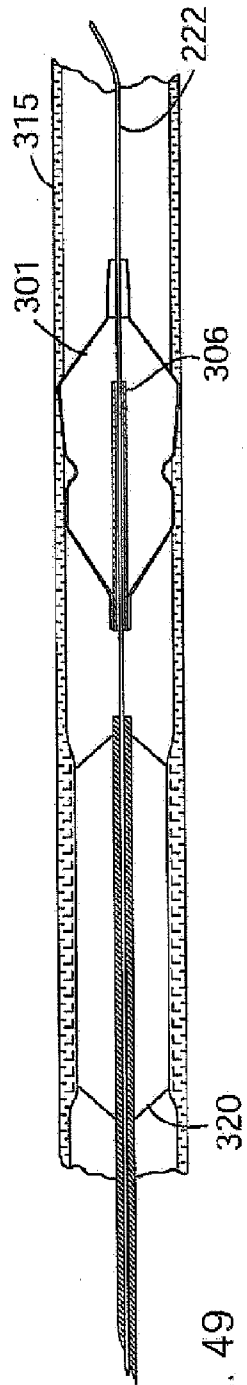

FIG. 49

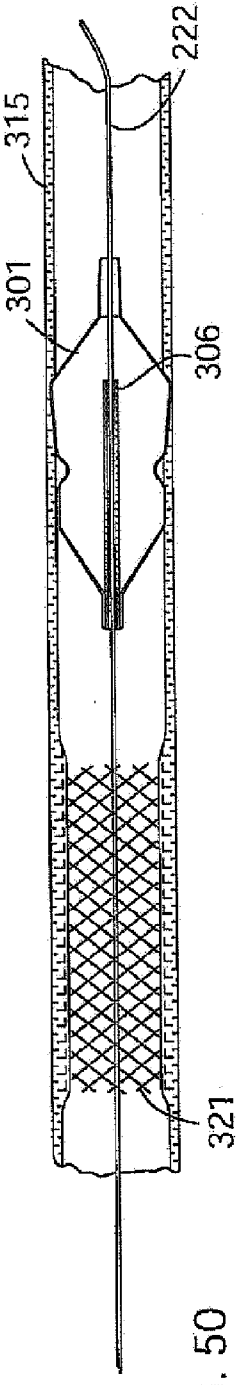

FIG. 50

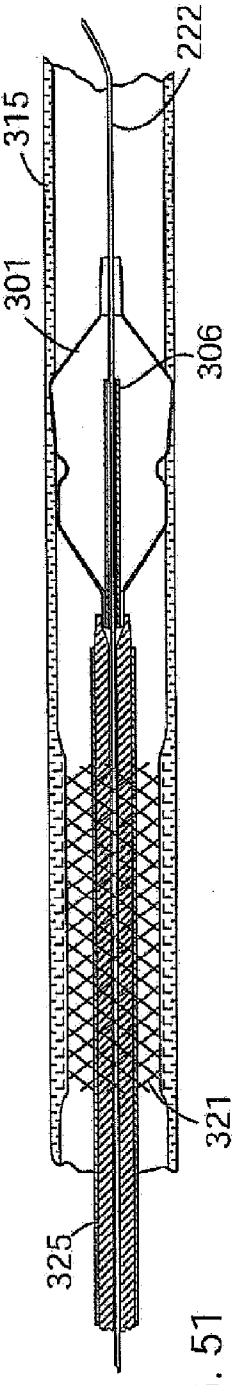

FIG. 51

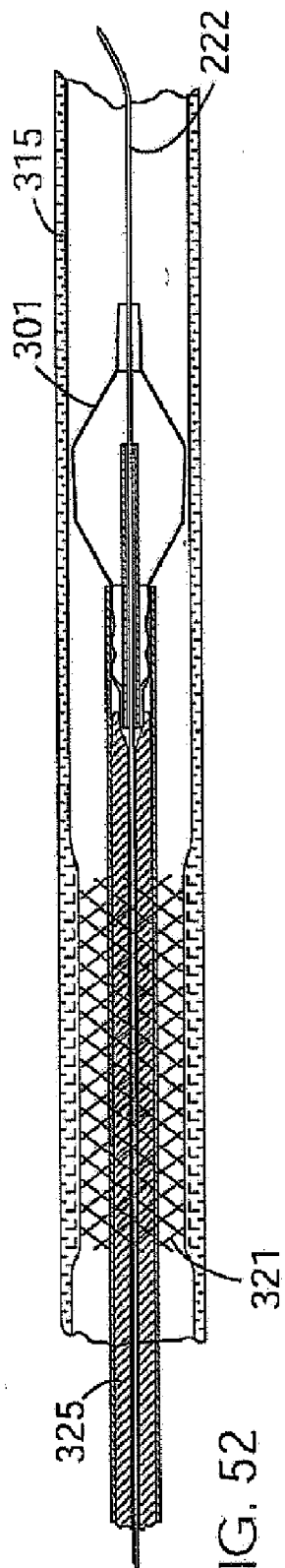

FIG. 52

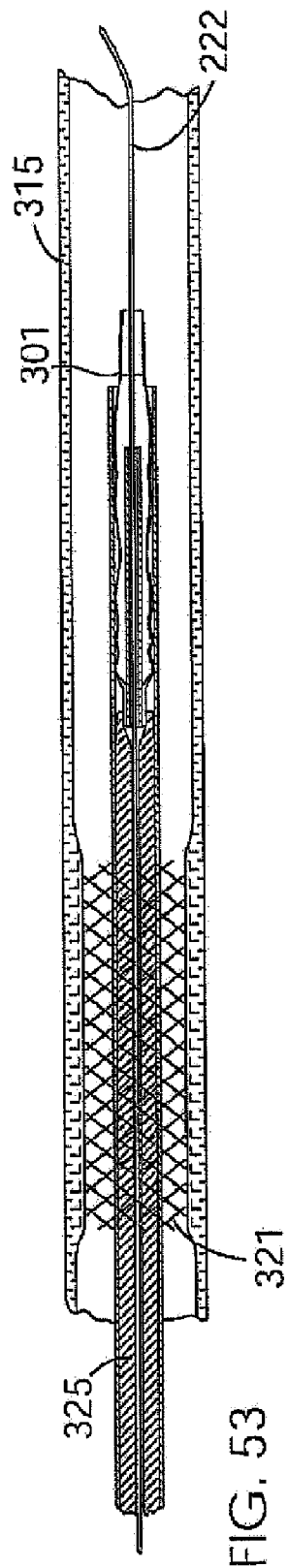

FIG. 53

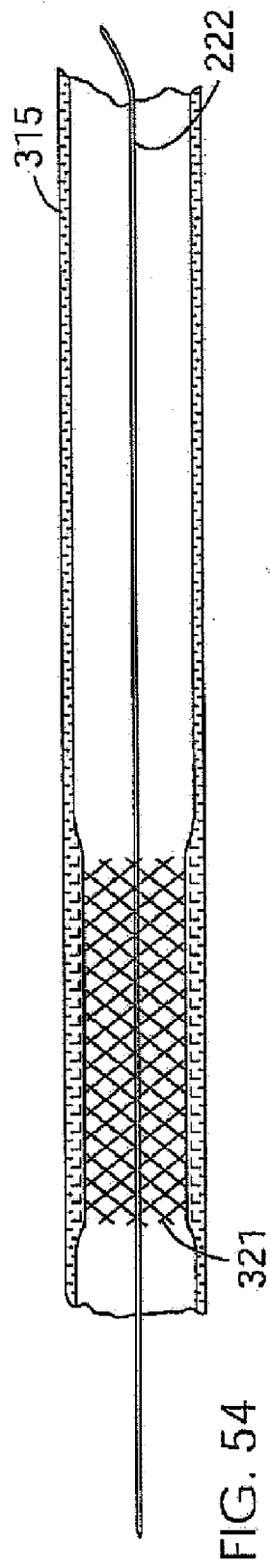

FIG. 54

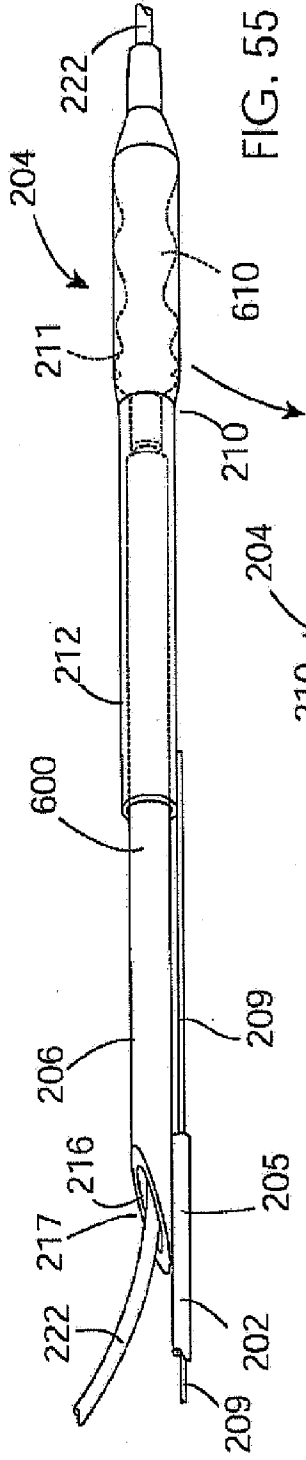

FIG. 55

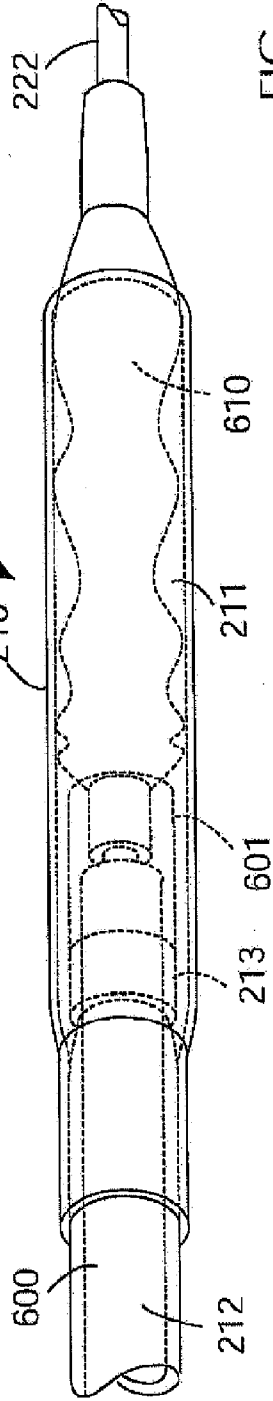

FIG. 56

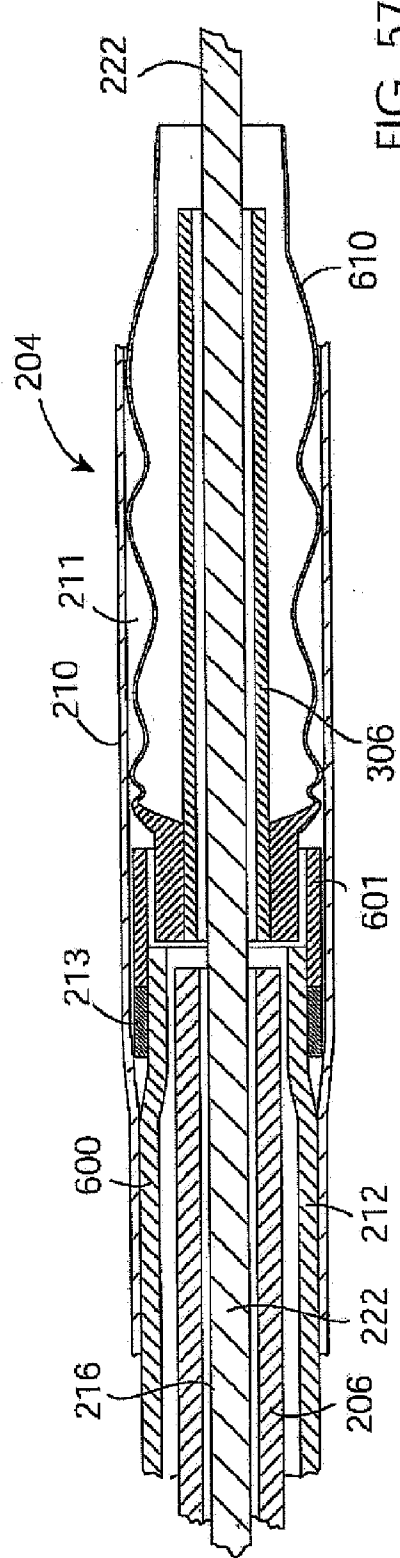

FIG. 57

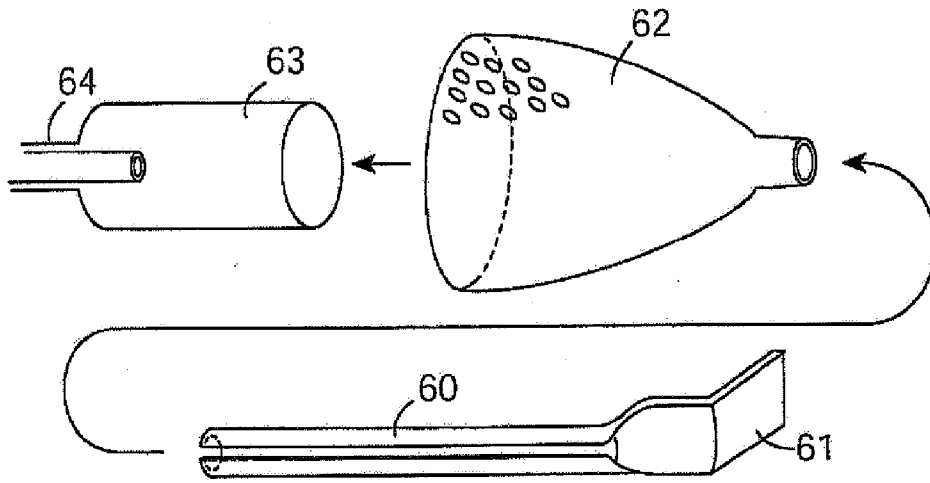

FIG. 58

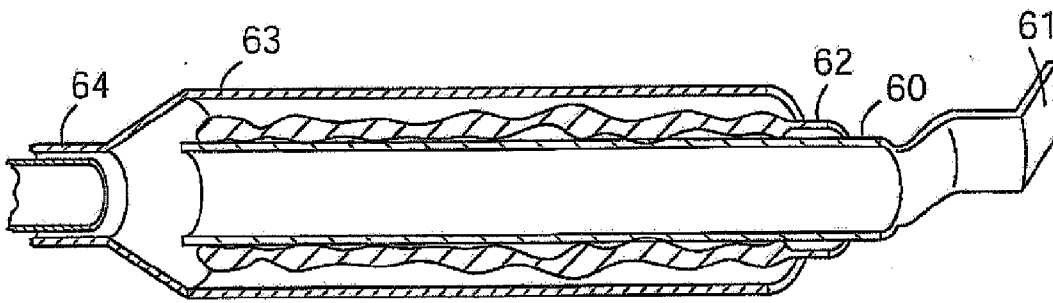

FIG. 59

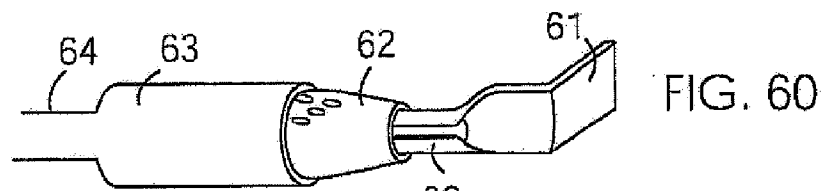

FIG. 60

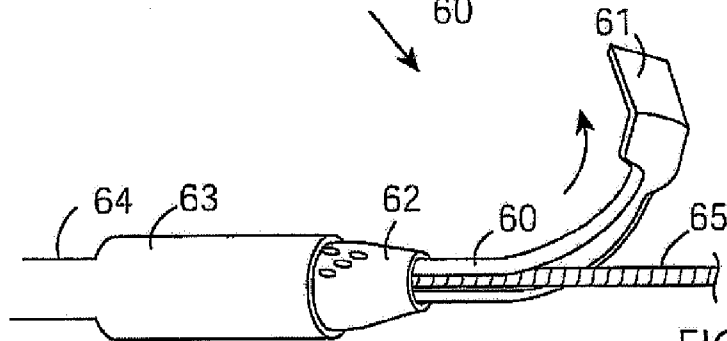

FIG. 61

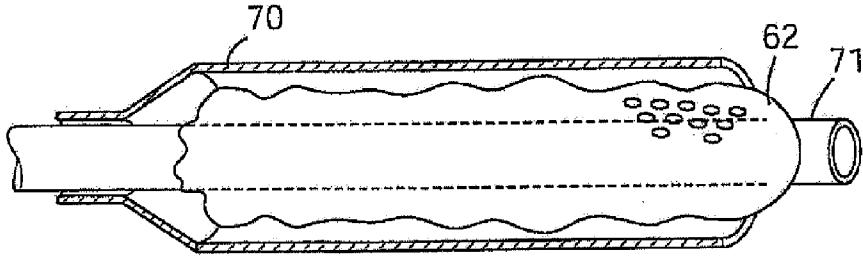

FIG. 62

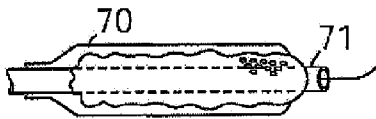

FIG. 63

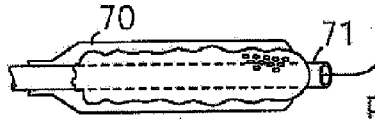

FIG. 66

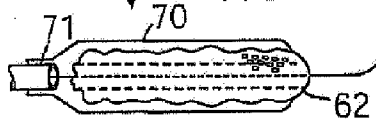

FIG. 64

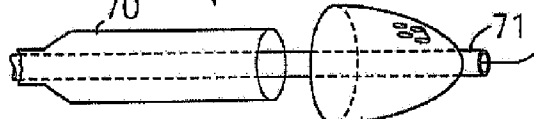

FIG. 67

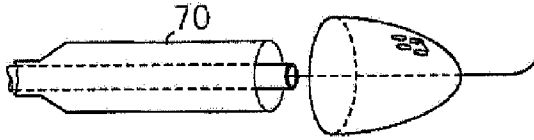

FIG. 65

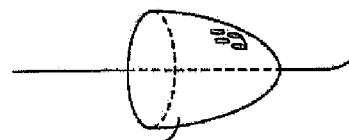

FIG. 68

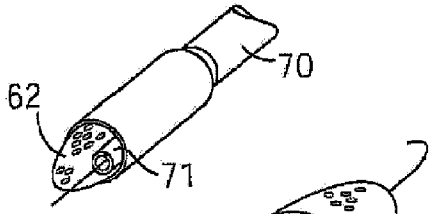

FIG. 69

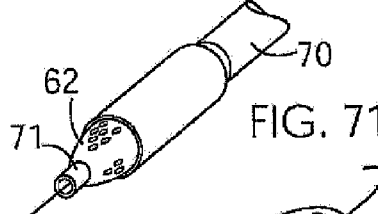

FIG. 71

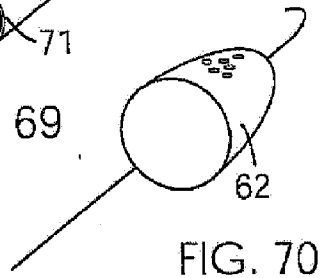

FIG. 70

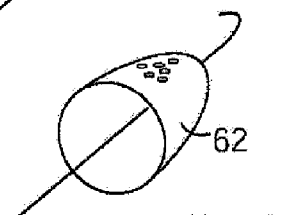

FIG. 72

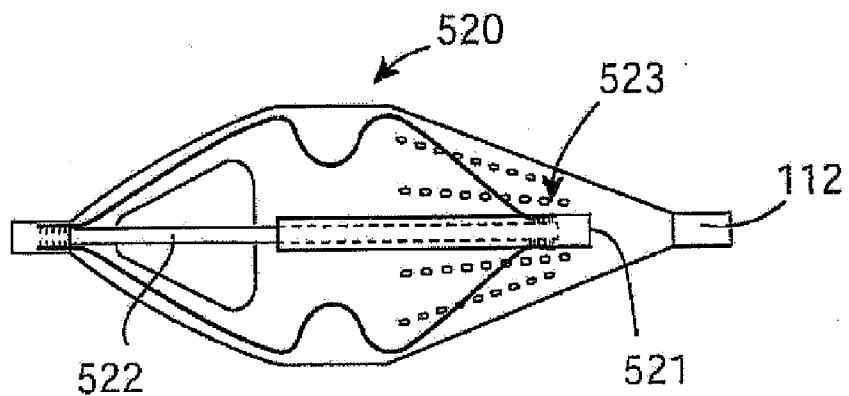

FIG. 73

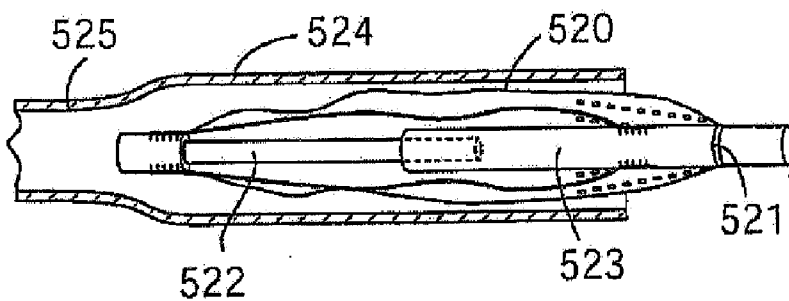

FIG. 74

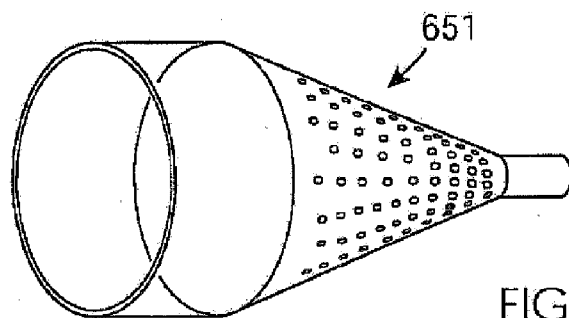

FIG. 75

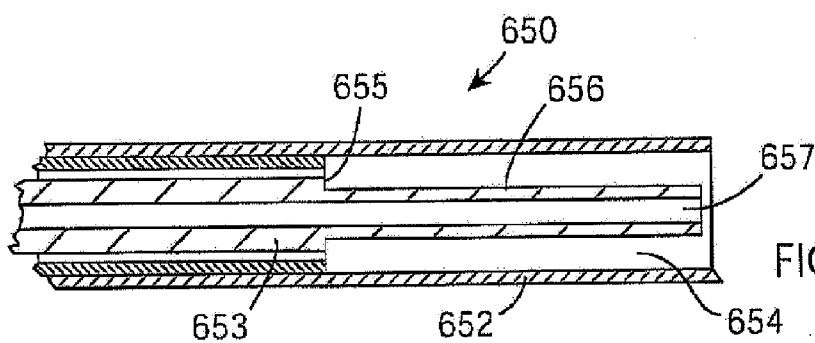

FIG. 76

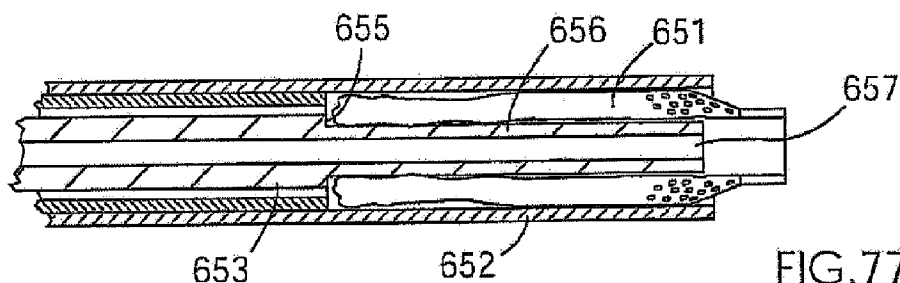

FIG. 77

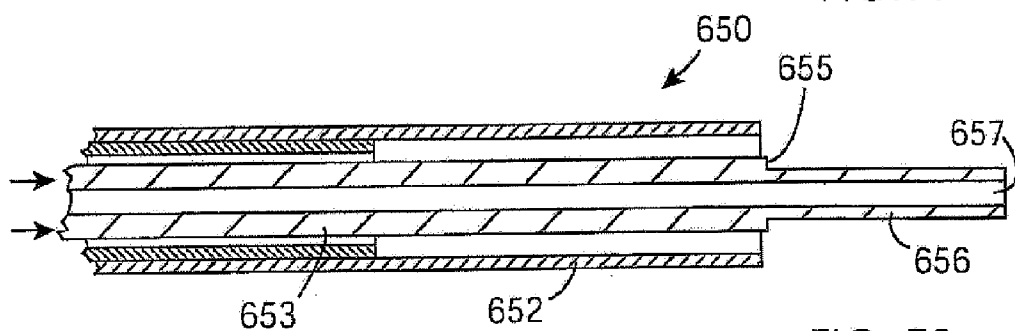

FIG. 78

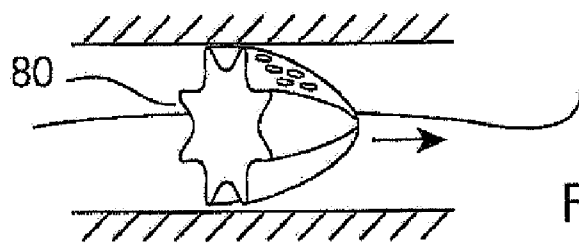

FIG. 79

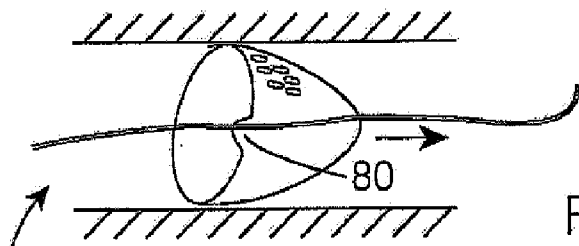

FIG. 80

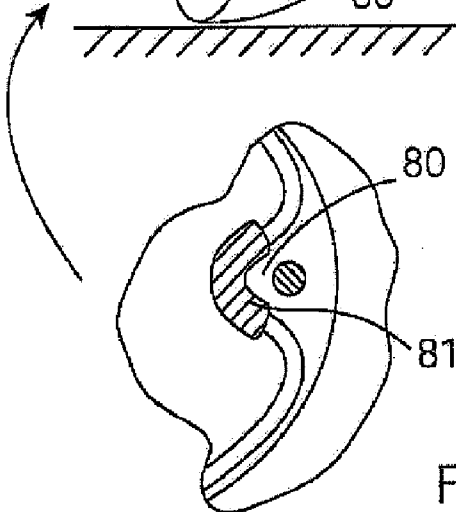

FIG. 81

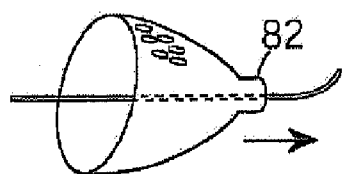

FIG. 82

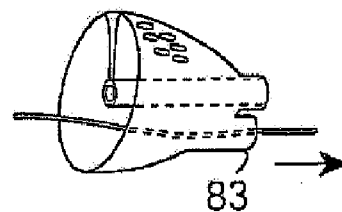

FIG. 83

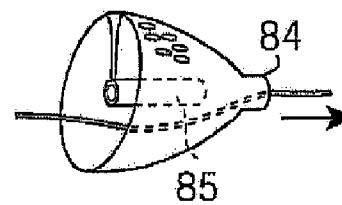

FIG. 84

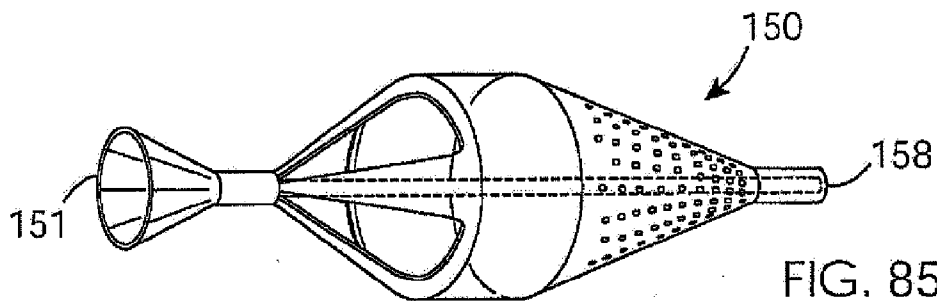

FIG. 85

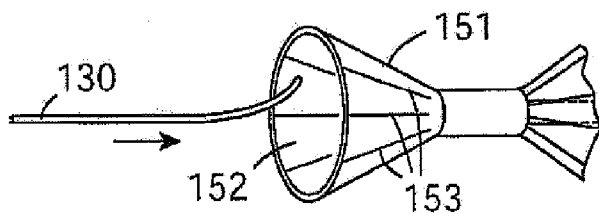

FIG. 86

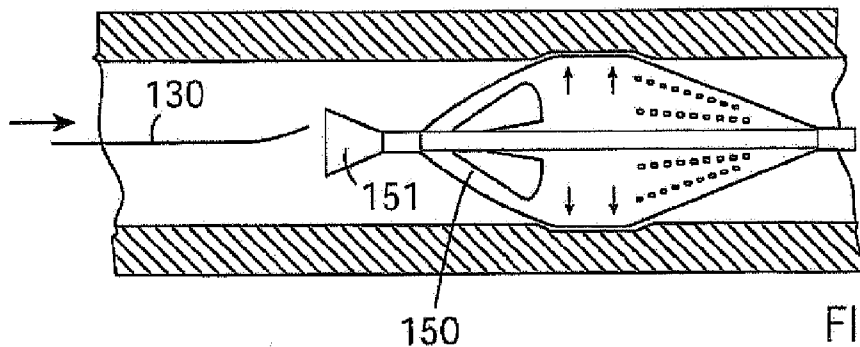

FIG. 87

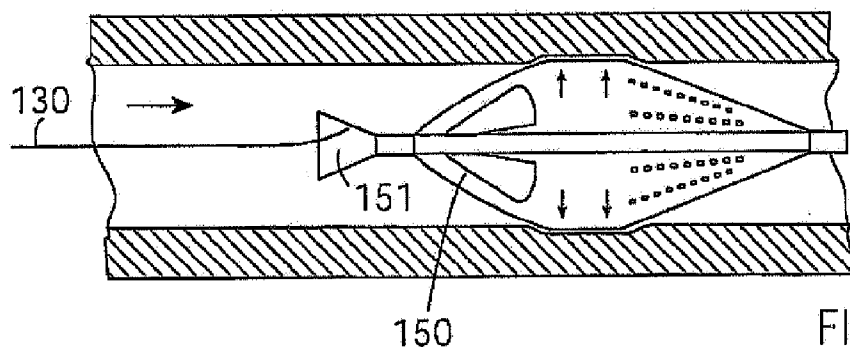

FIG. 88

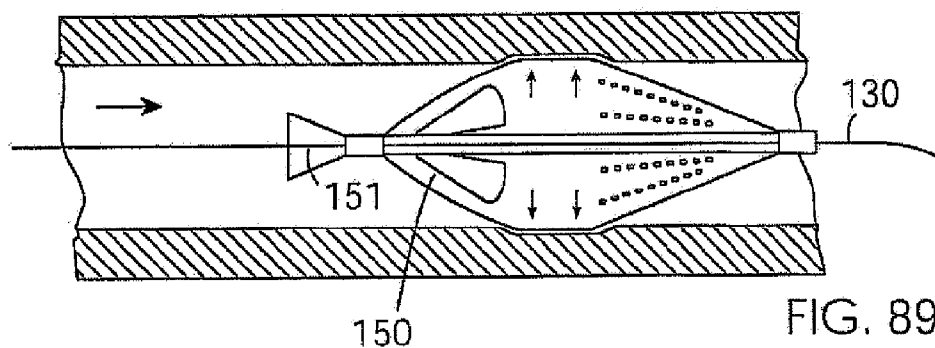

FIG. 89

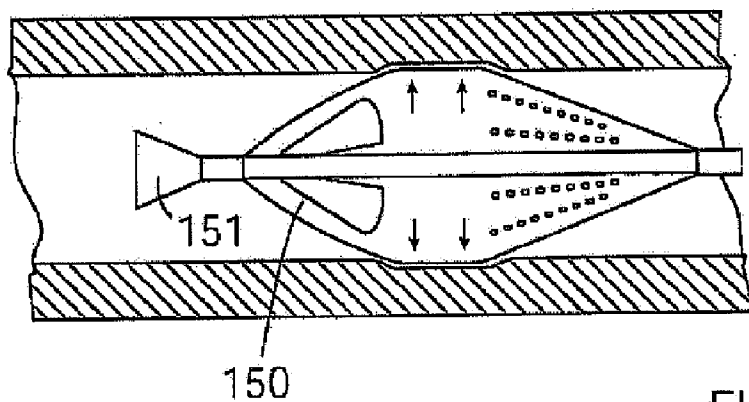

FIG. 90

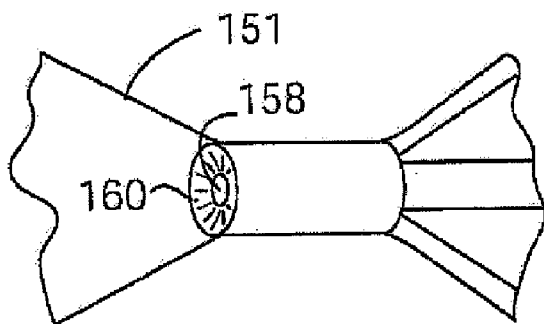

FIG. 91

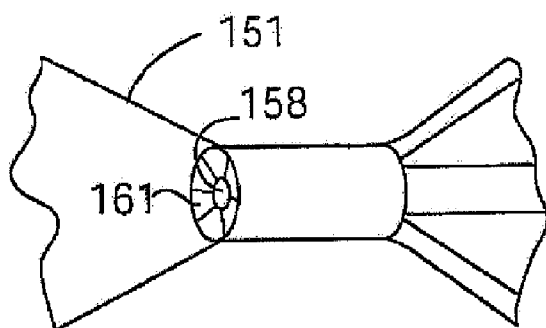

FIG. 92

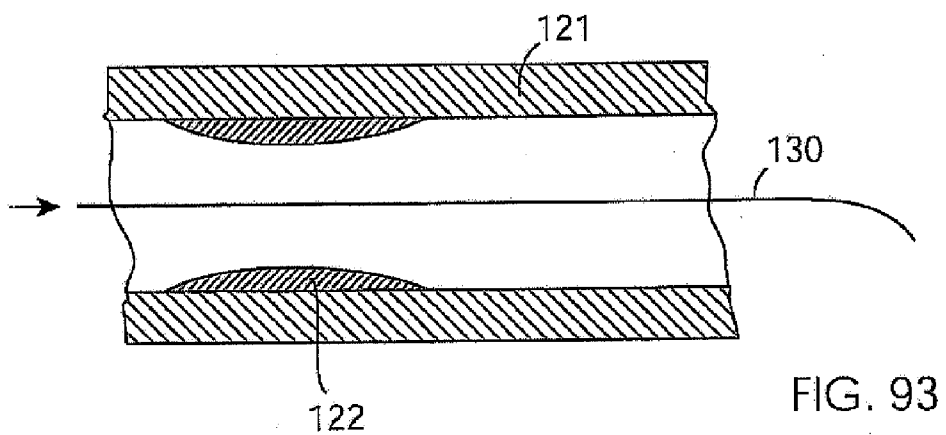

FIG. 93

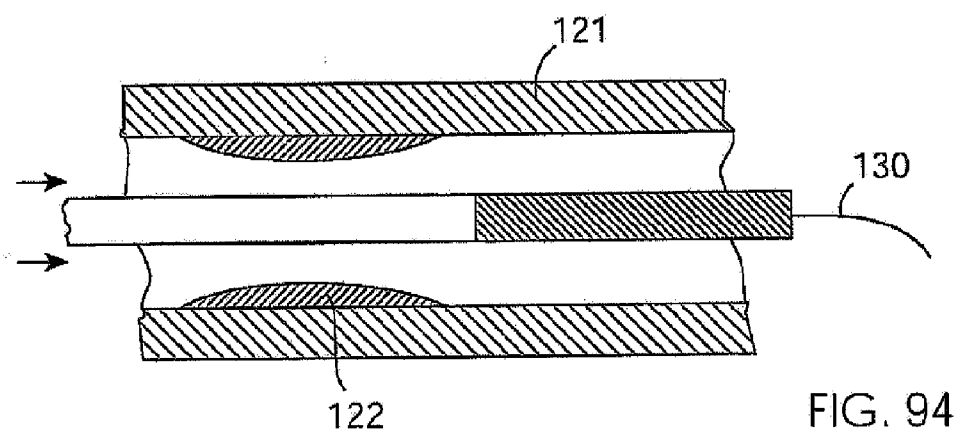

FIG. 94

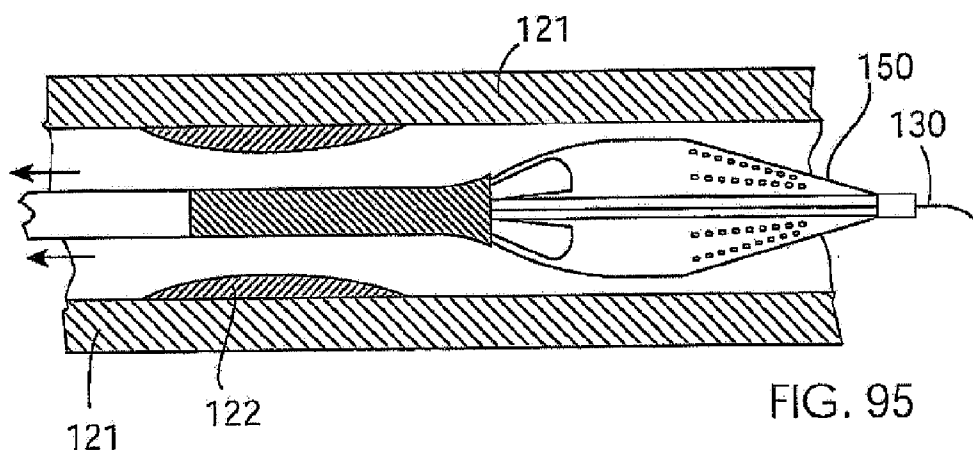
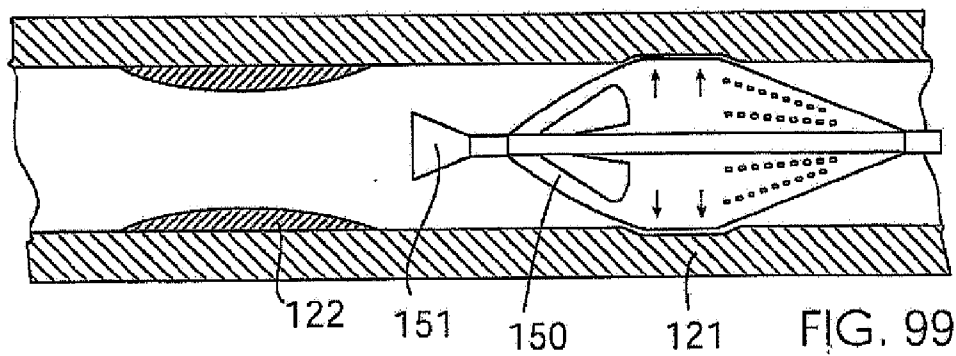
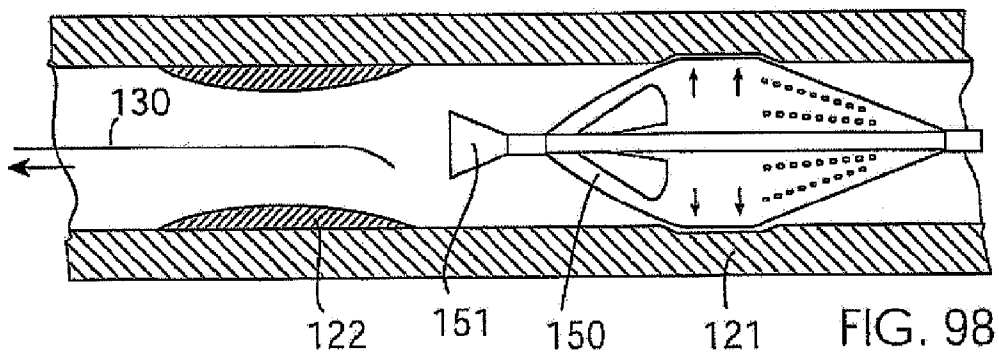
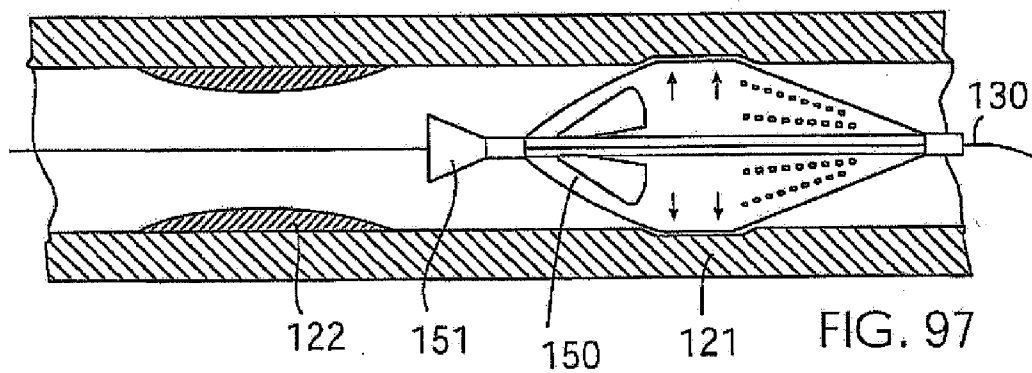
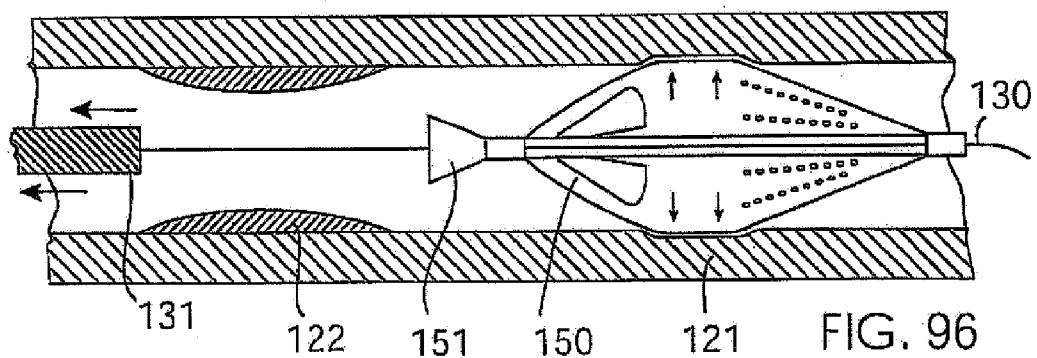
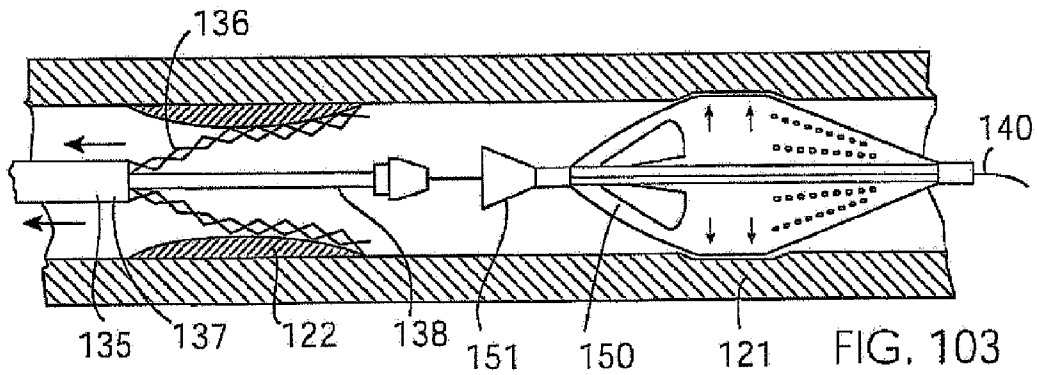
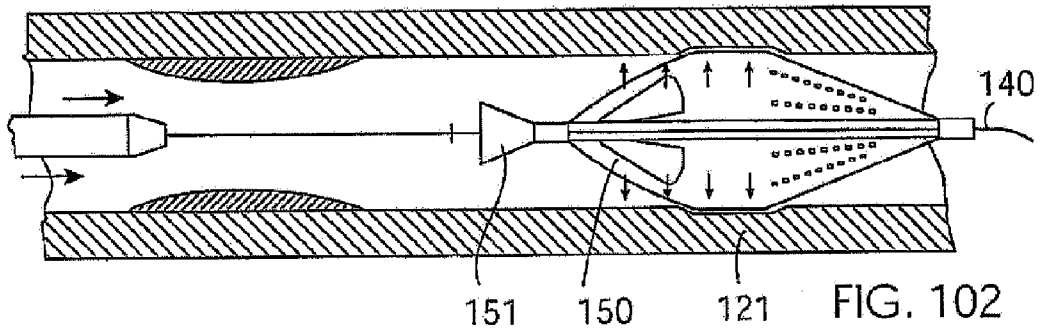
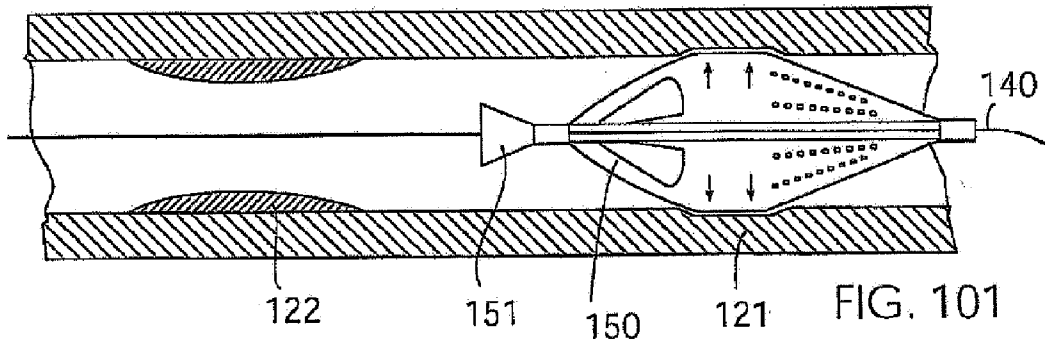
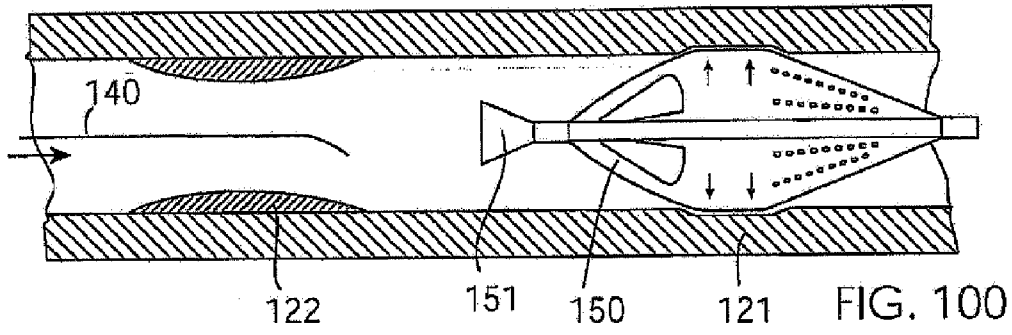
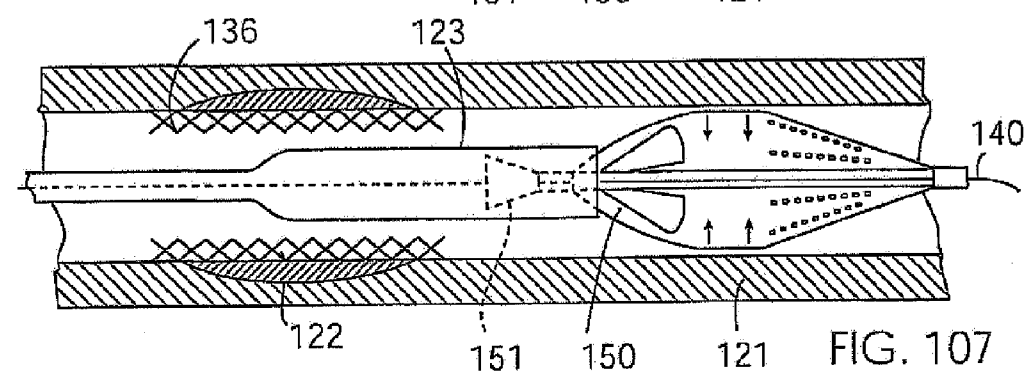
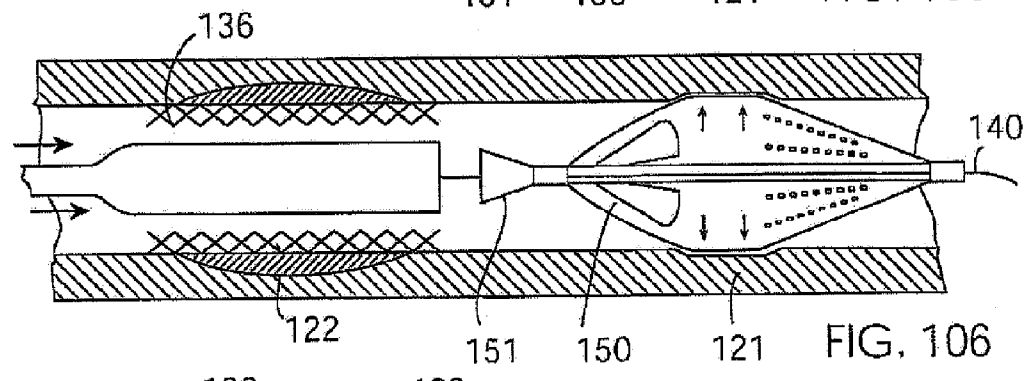
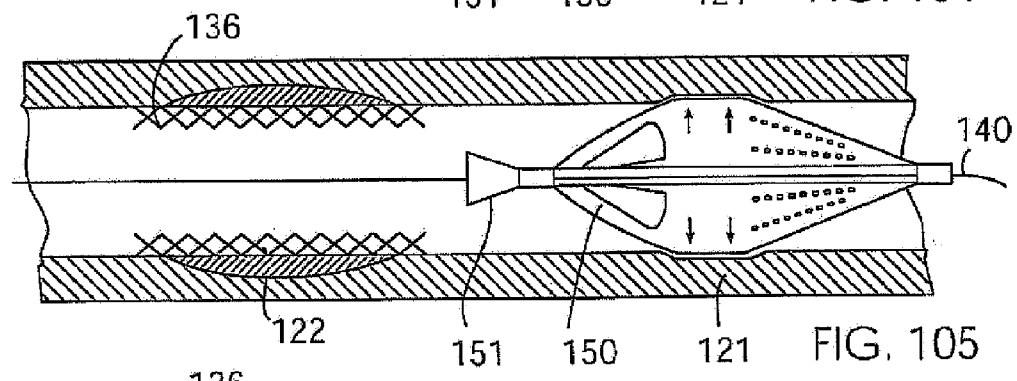
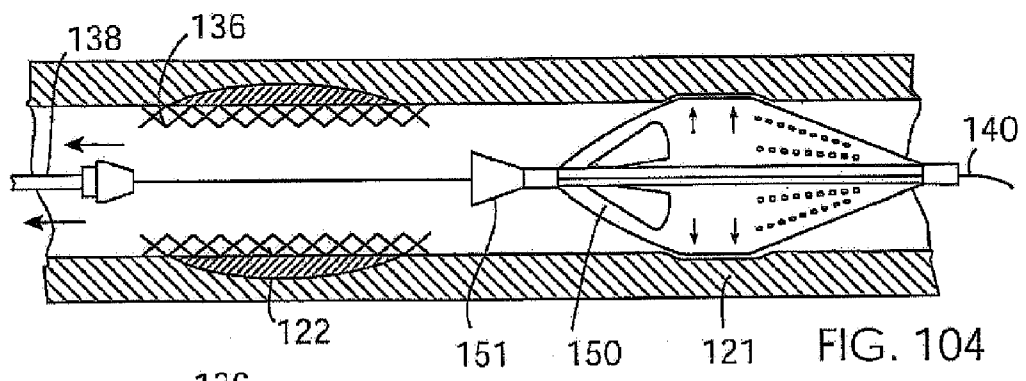
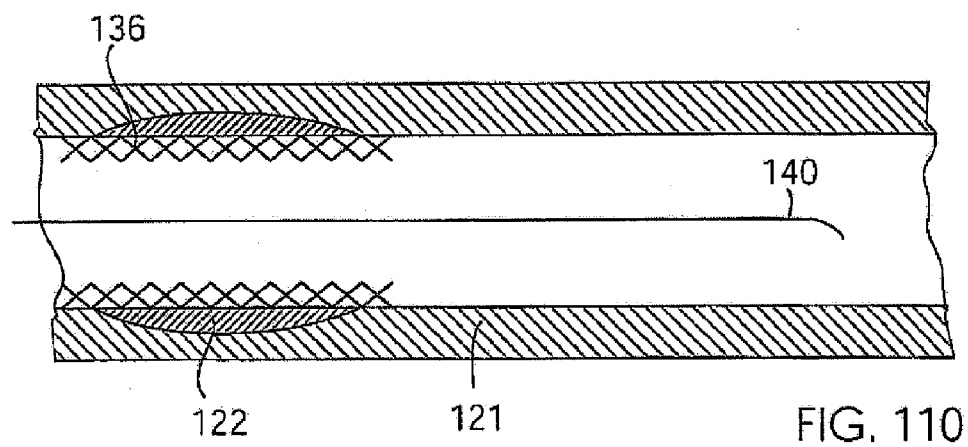
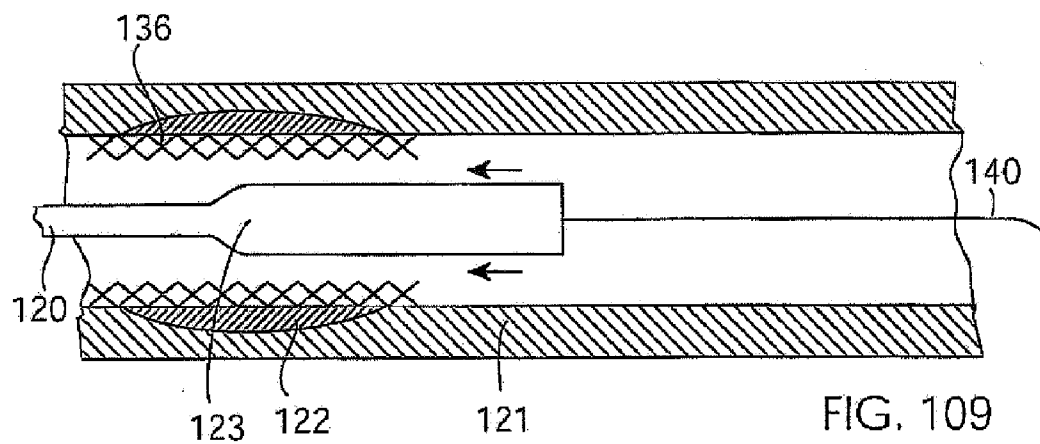
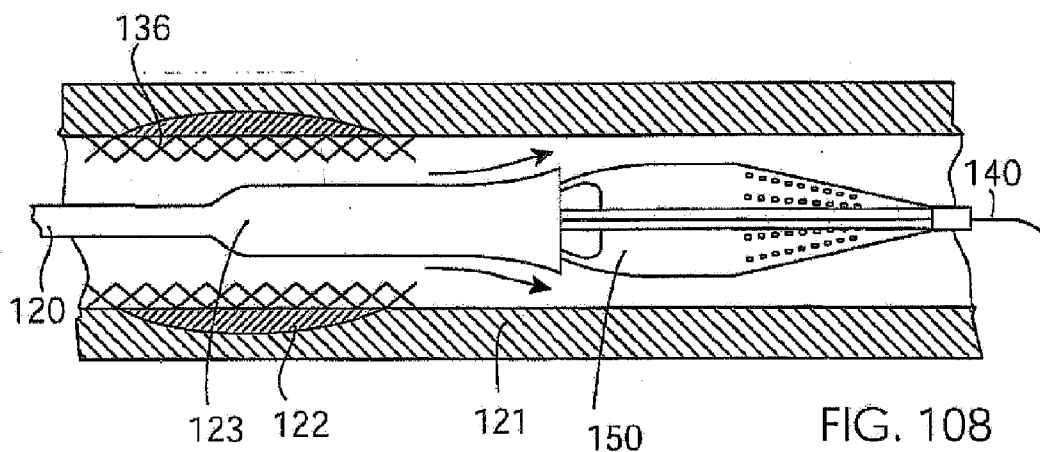

FIG. 95









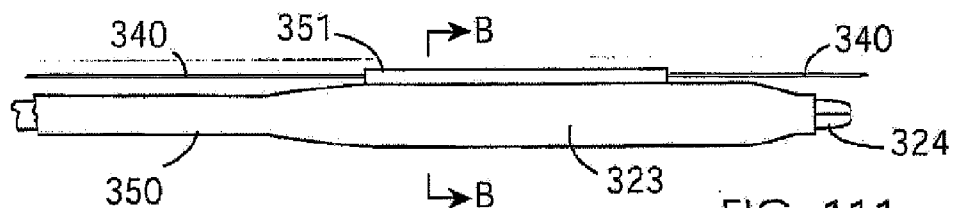

FIG. 111

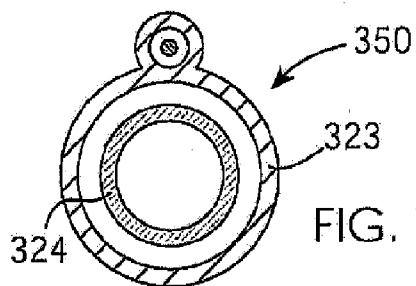

FIG. 112

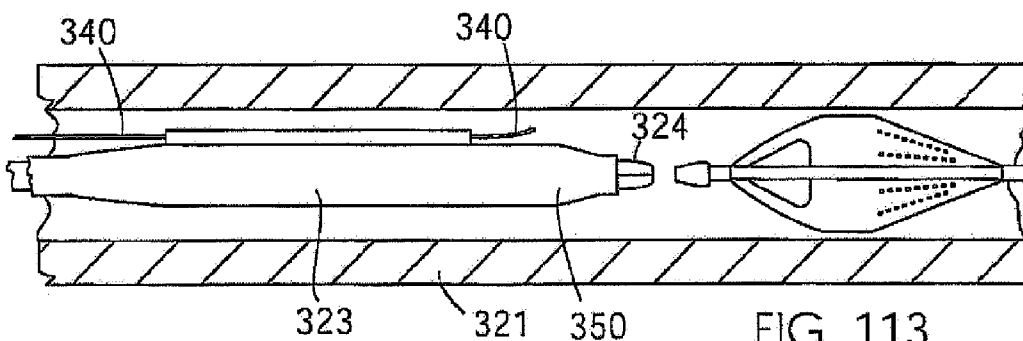

FIG. 113

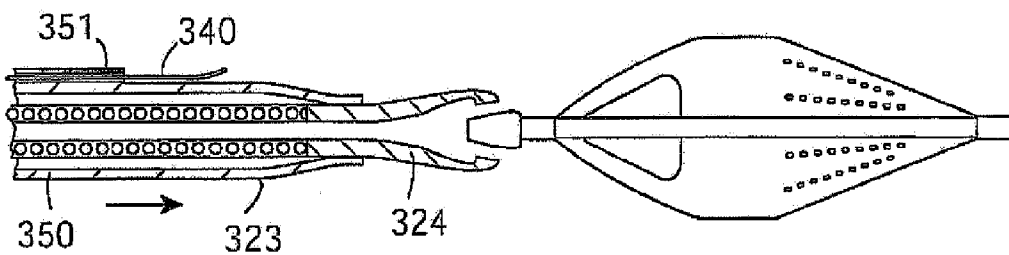

FIG. 114

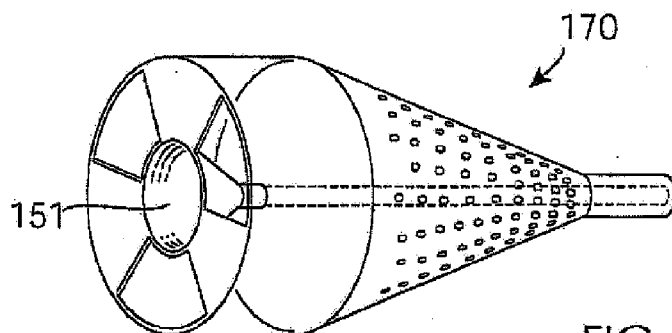

FIG. 115

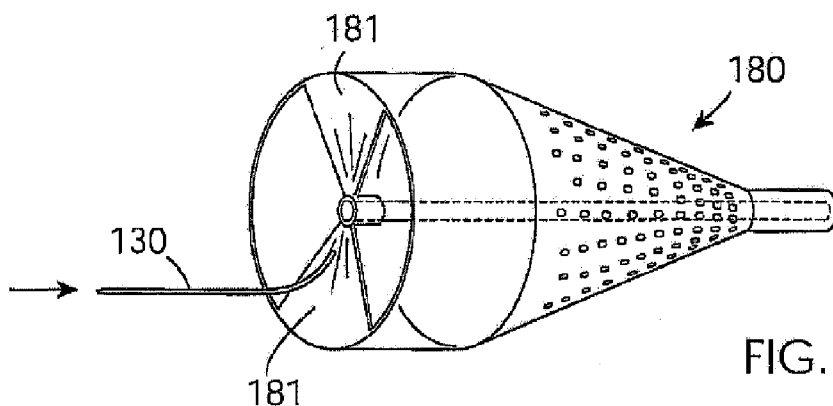

FIG. 116

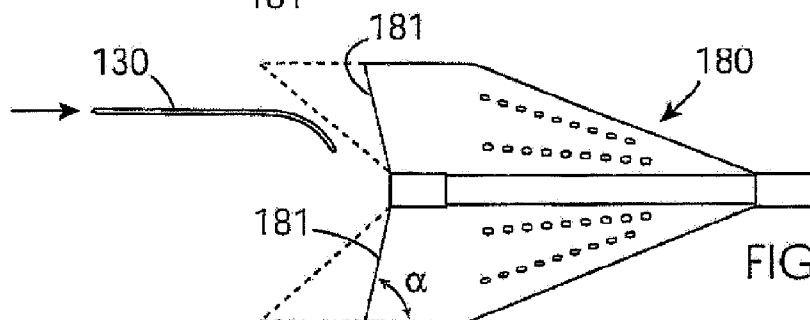

FIG. 117

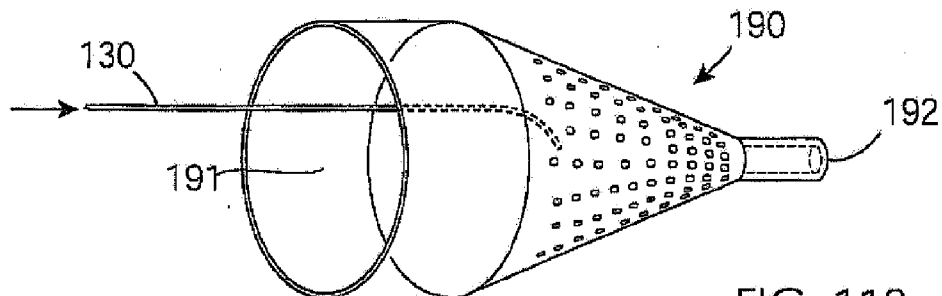
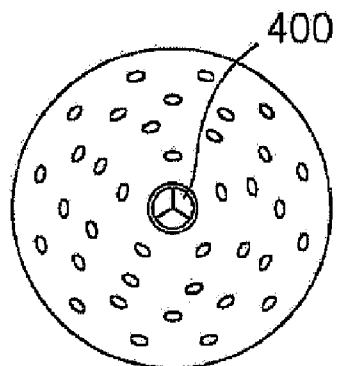
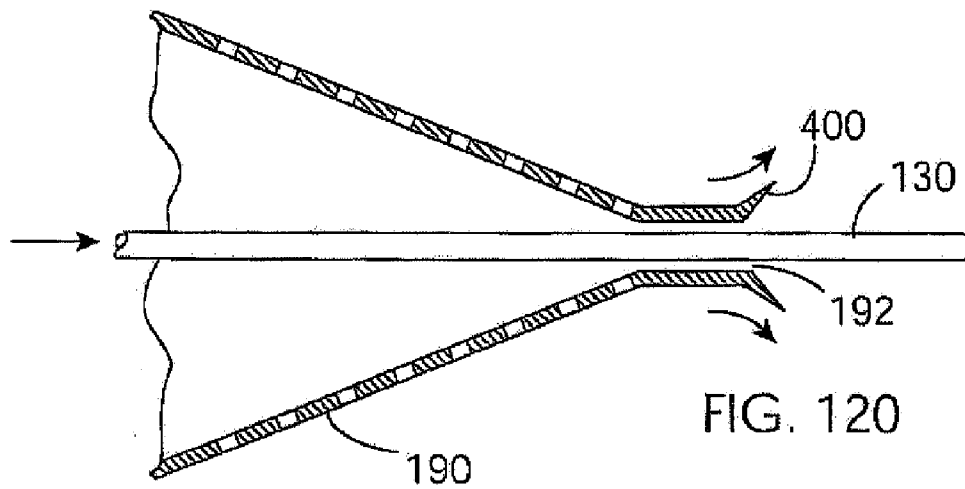
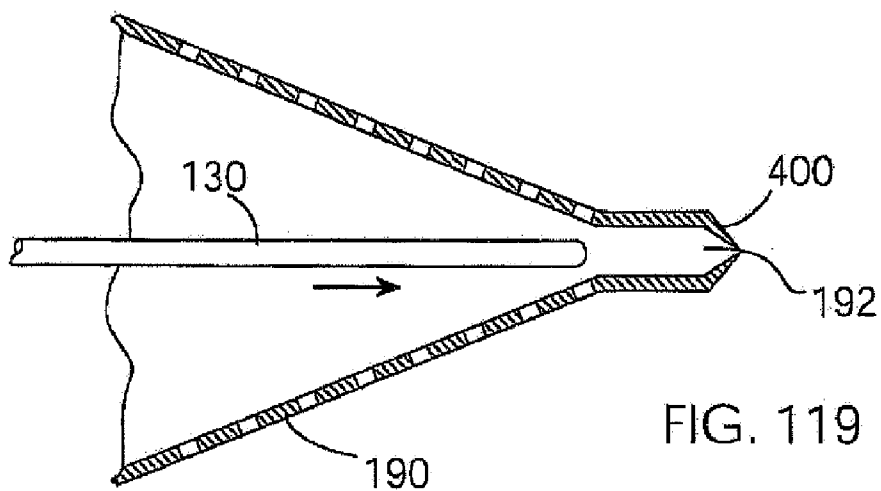

FIG. 118



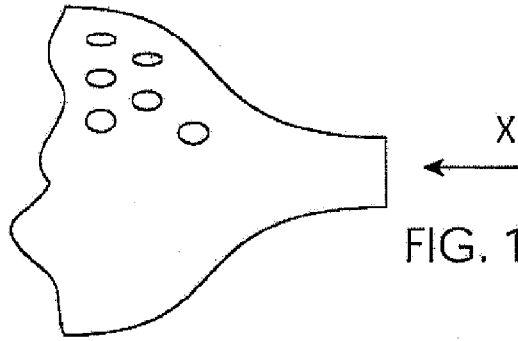

FIG. 122

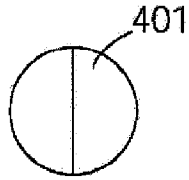

FIG. 123

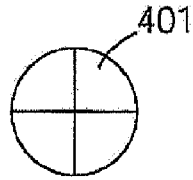

FIG. 124

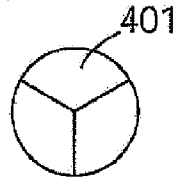

FIG. 125

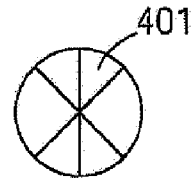

FIG. 126

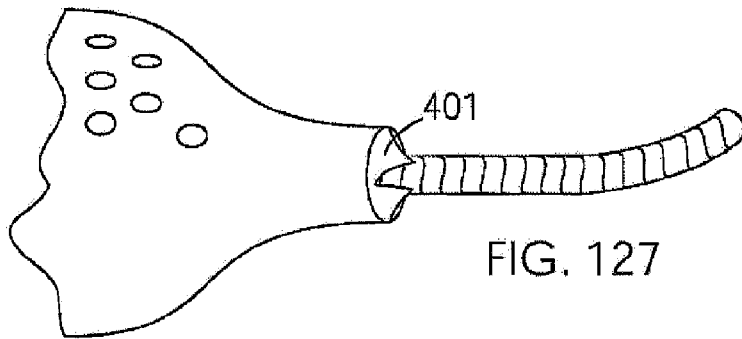

FIG. 127

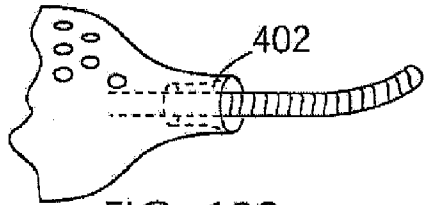

FIG. 128

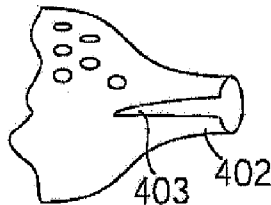

FIG. 129

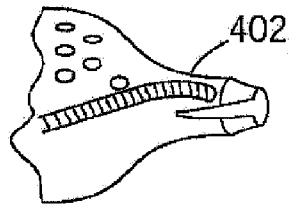

FIG. 130

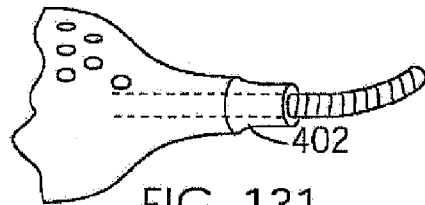

FIG. 131

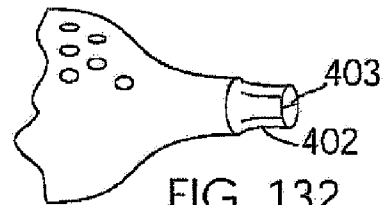

FIG. 132

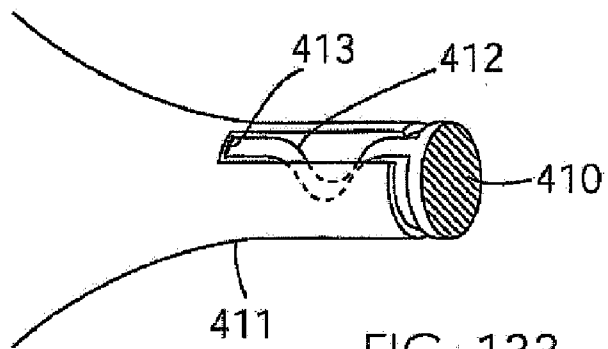

FIG. 133

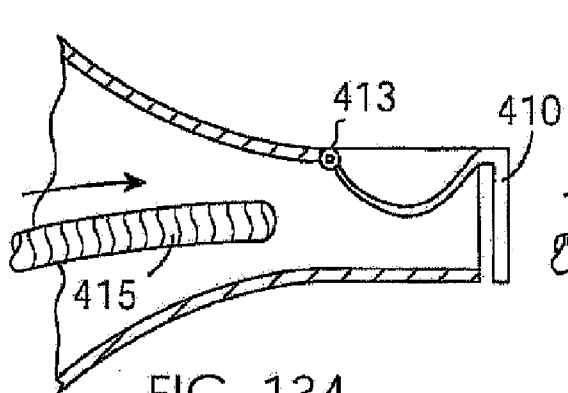

FIG. 134

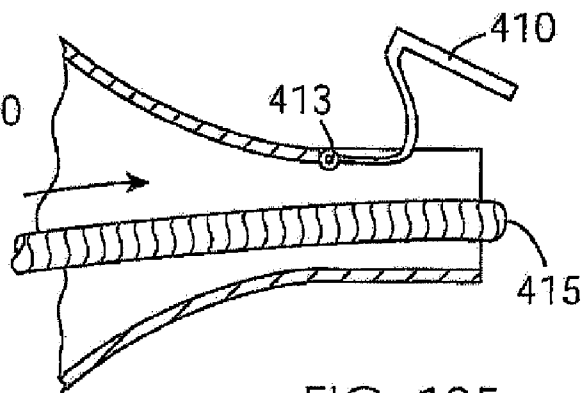

FIG. 135

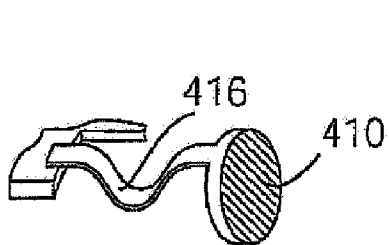

FIG. 136

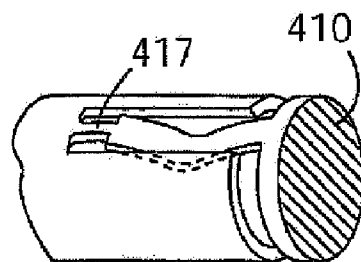

FIG. 137

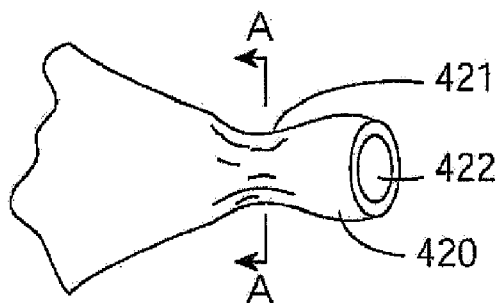

FIG. 138

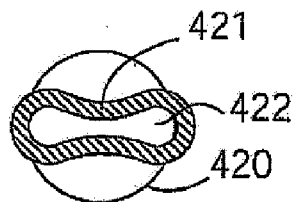

FIG. 139

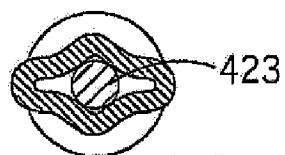

FIG. 140

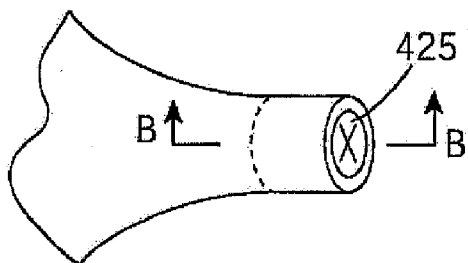

FIG. 141

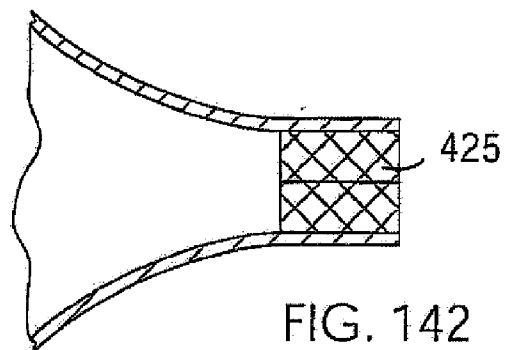

FIG. 142

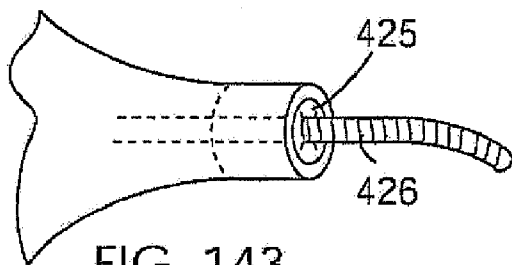

FIG. 143

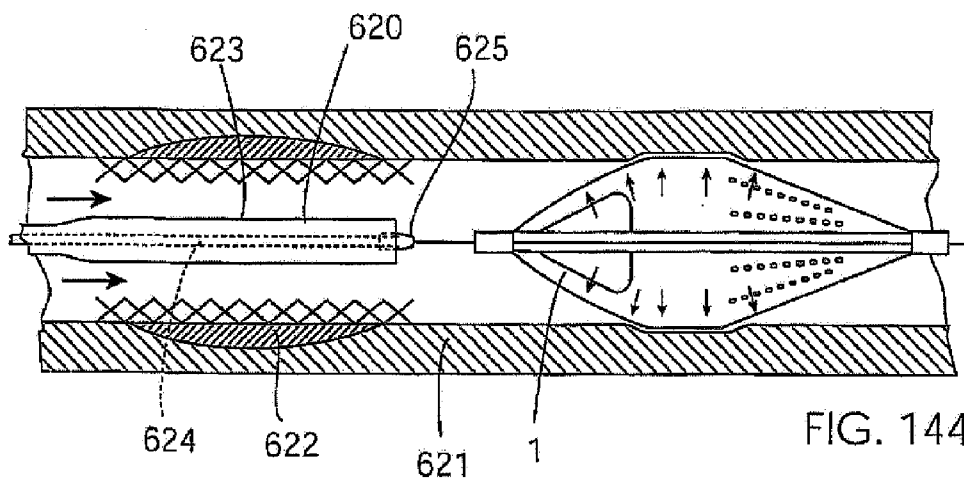

FIG. 144

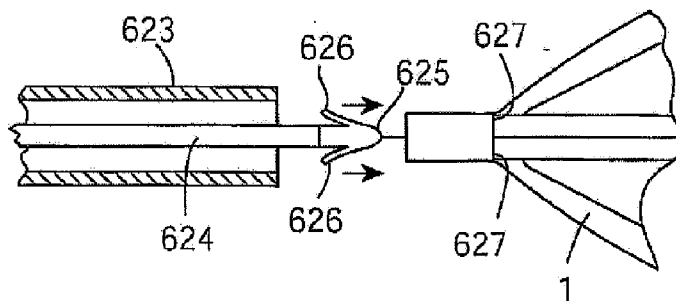

FIG. 145

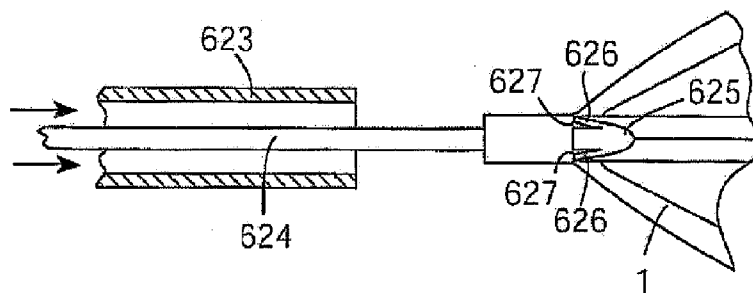

FIG. 146

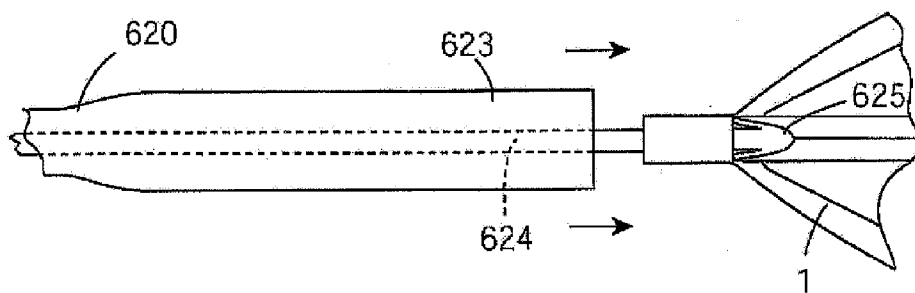

FIG. 147

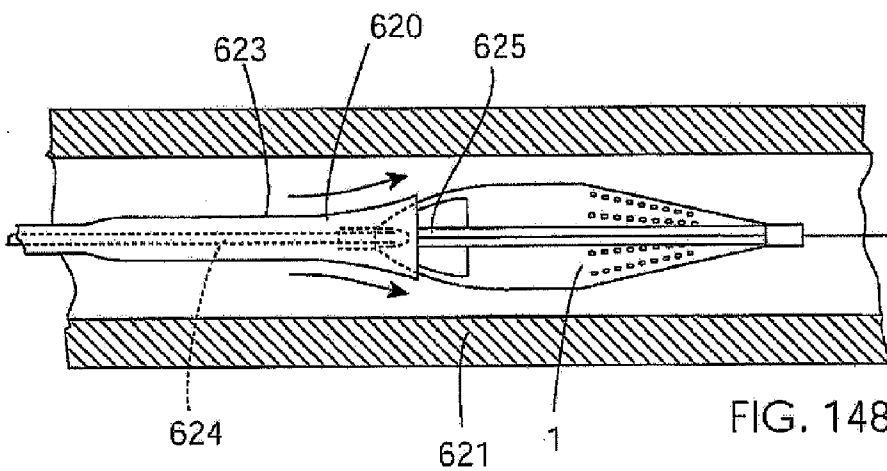

FIG. 148

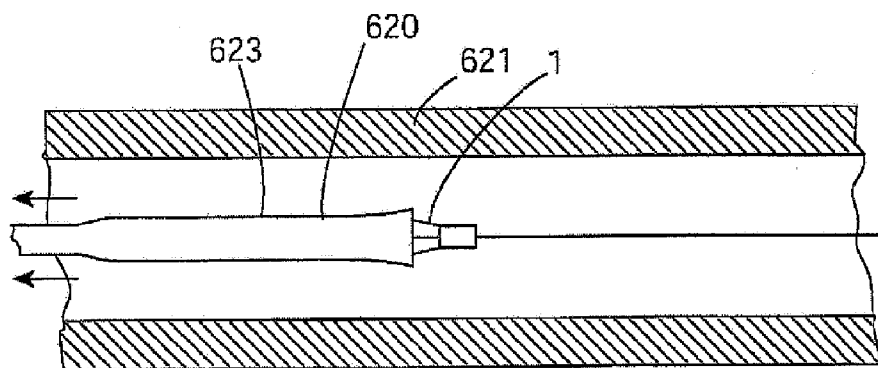

FIG. 149

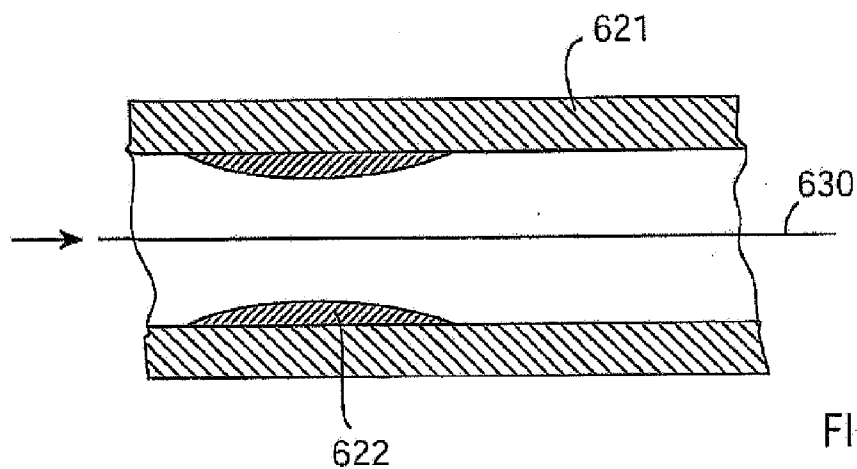

FIG. 150

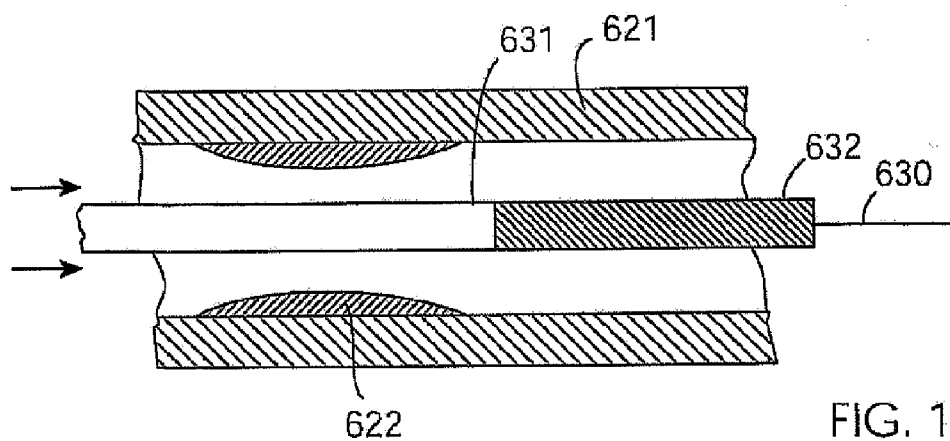

FIG. 151

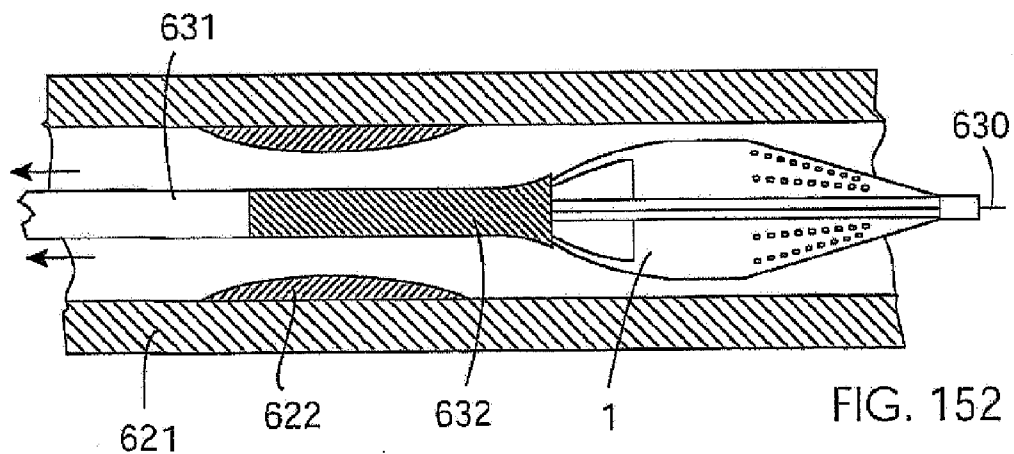
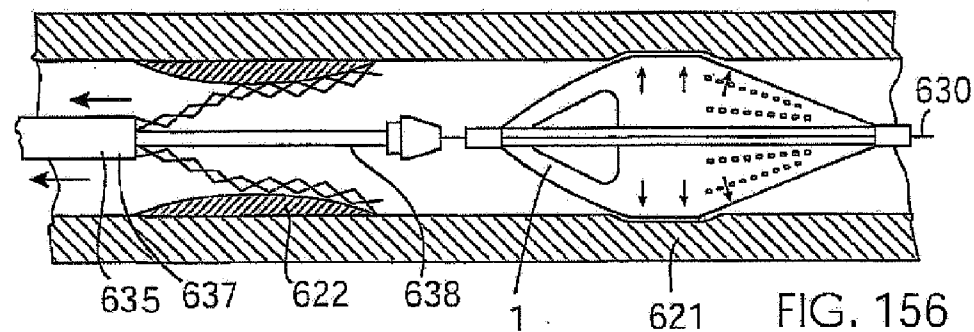
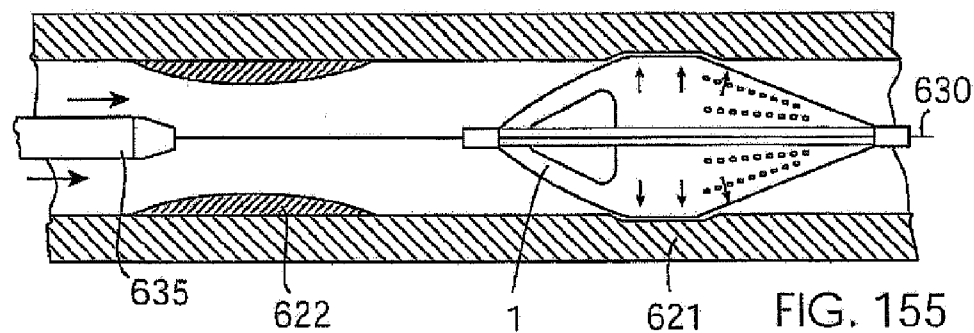
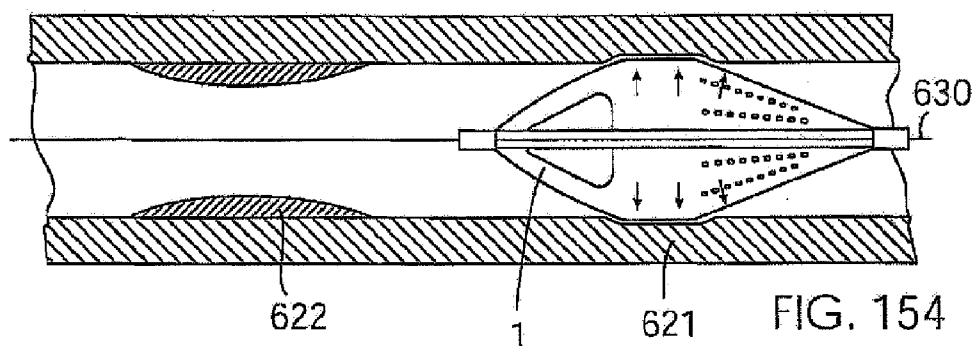
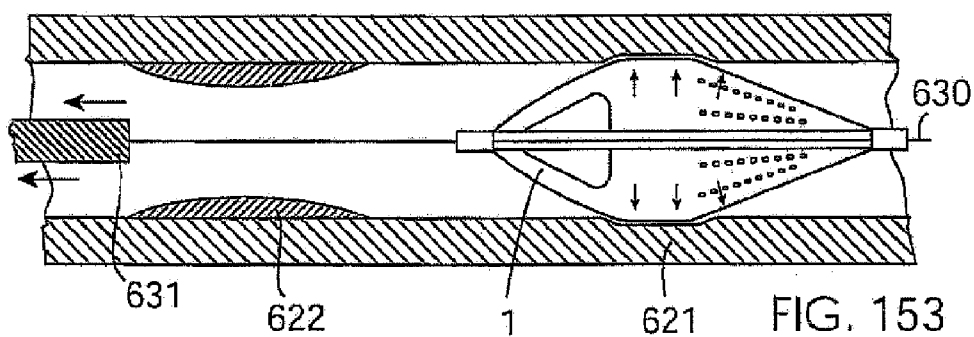
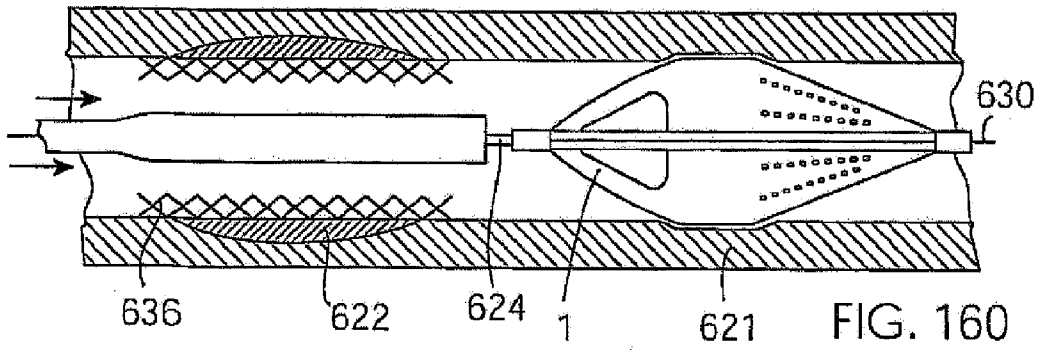
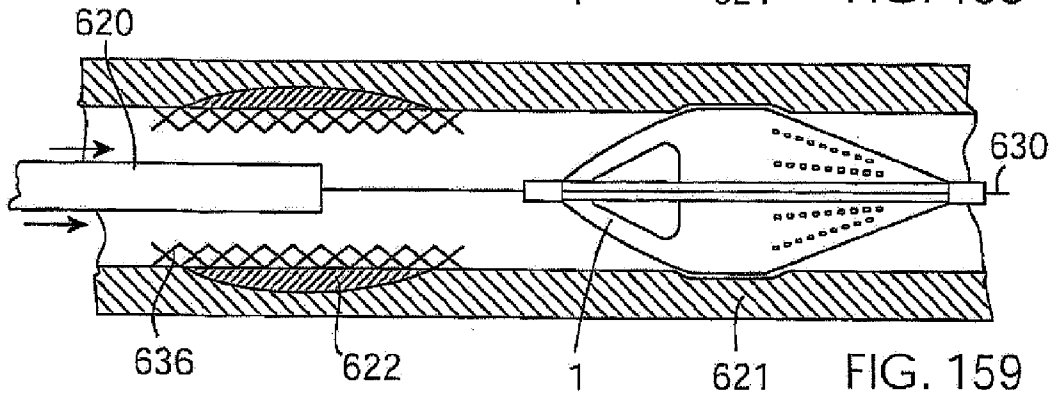
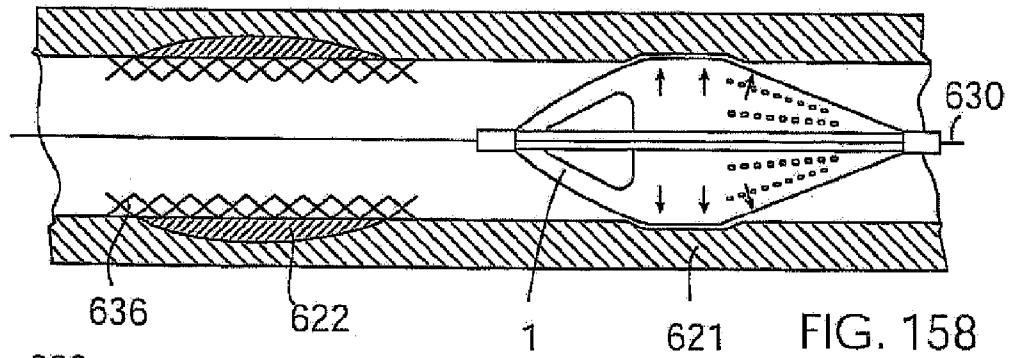
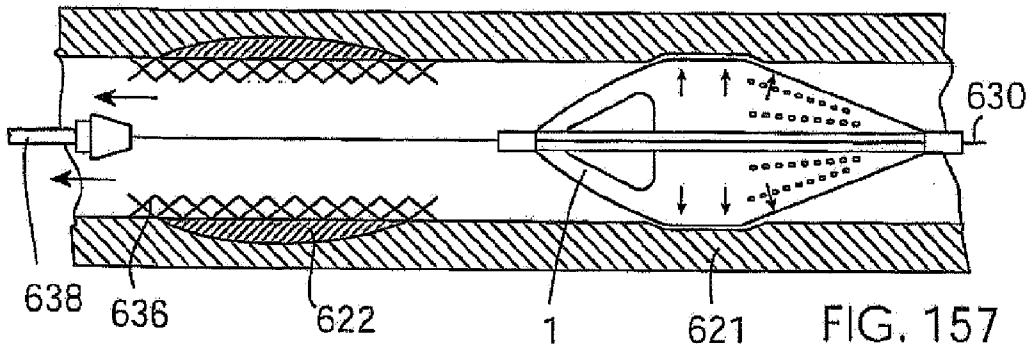
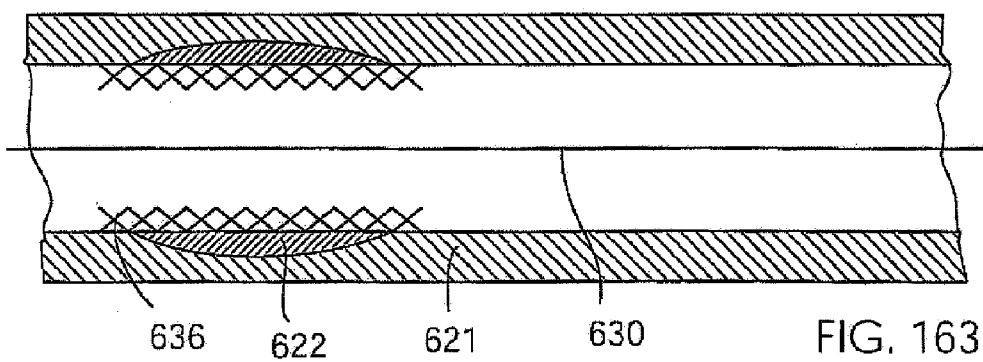
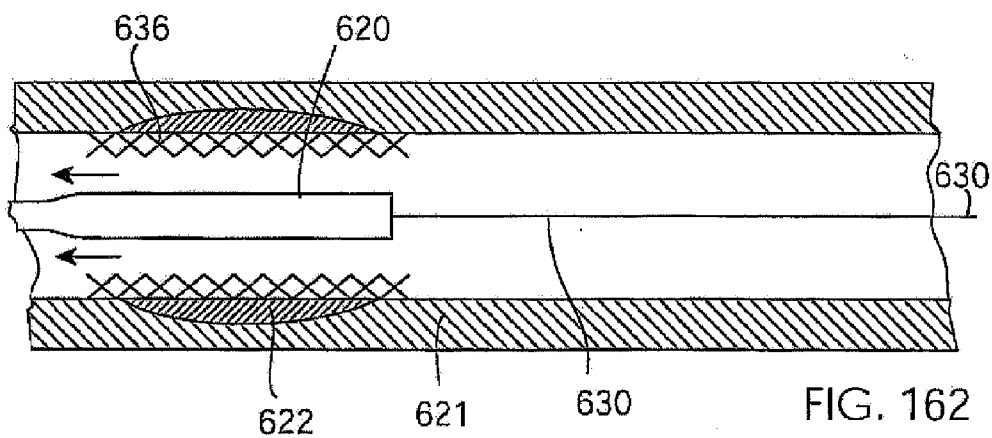
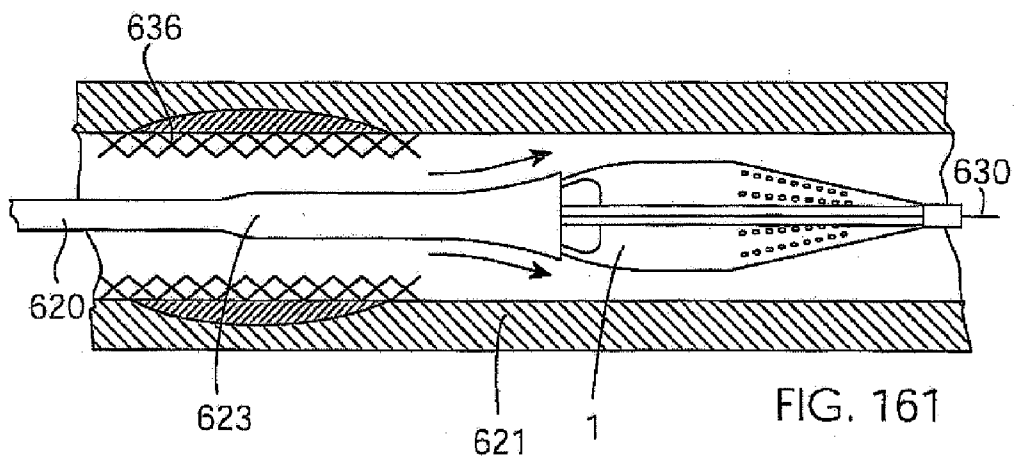

FIG. 152







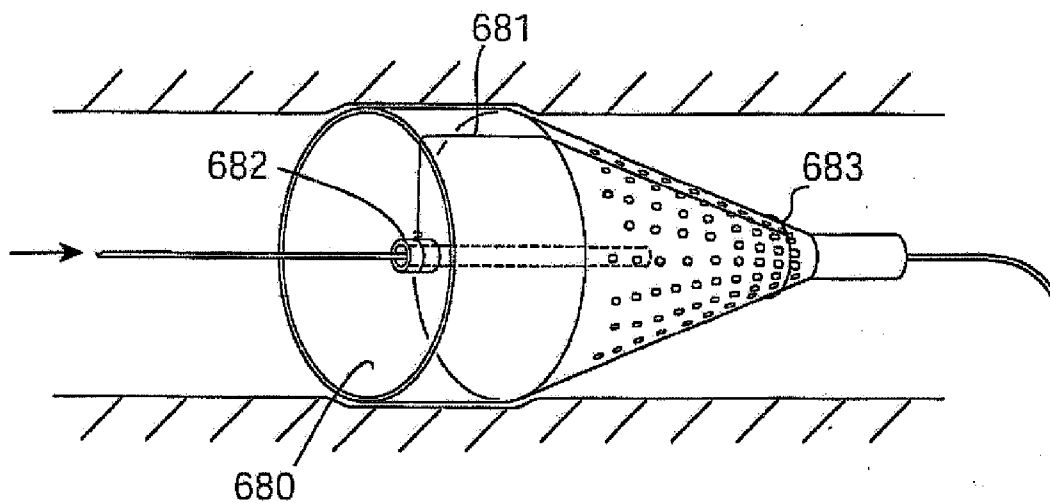

FIG. 164

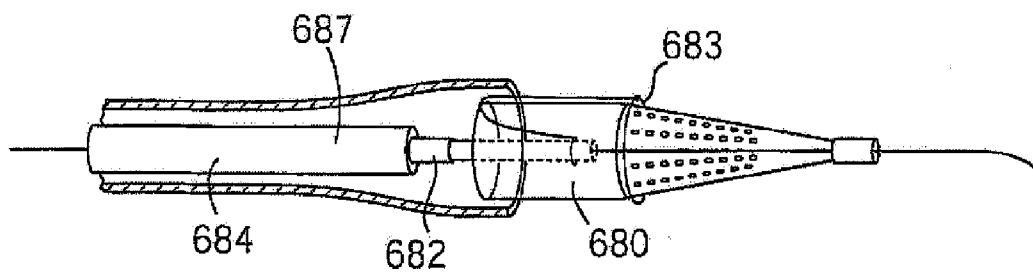

FIG. 165

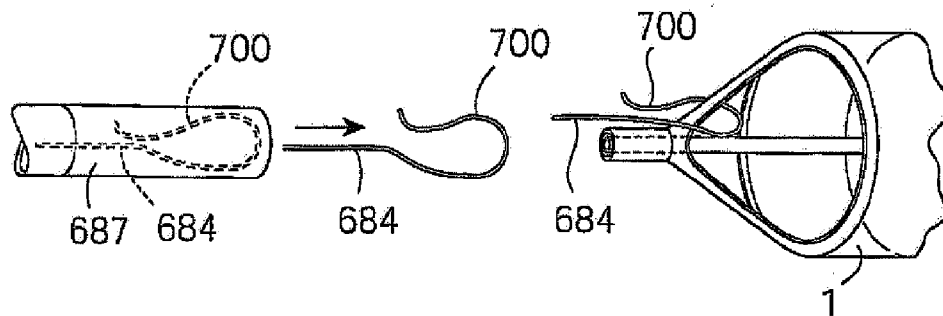

FIG. 166

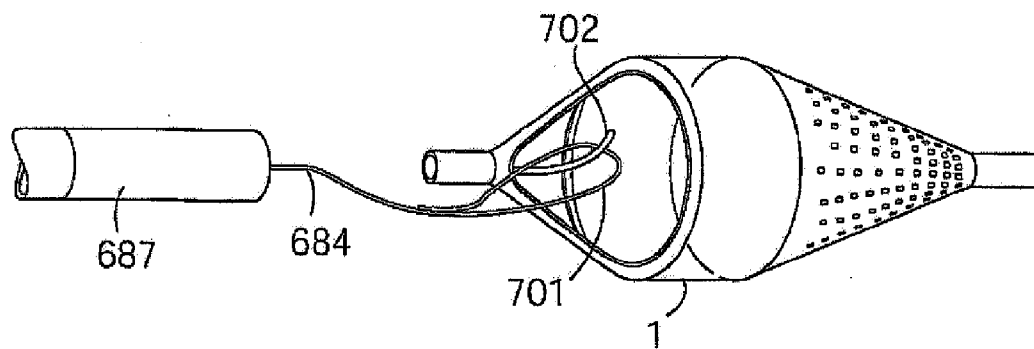

FIG. 167

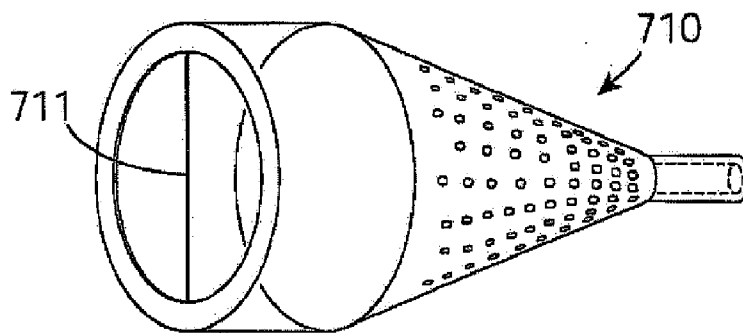

FIG. 168

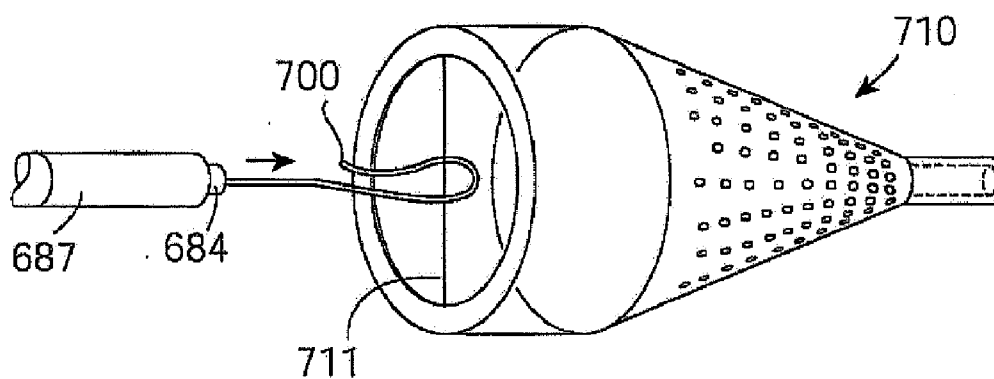

FIG. 169

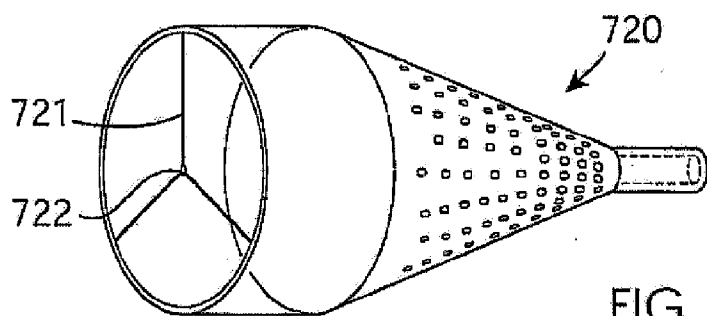

FIG. 170

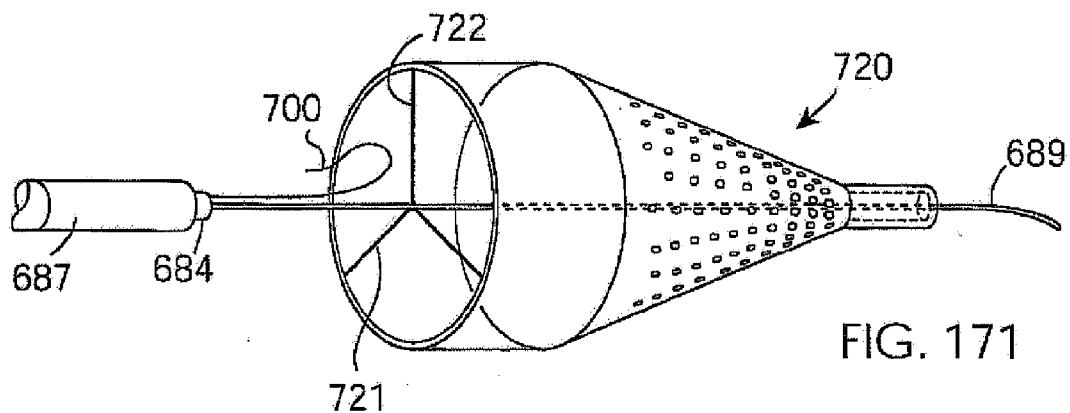

FIG. 171

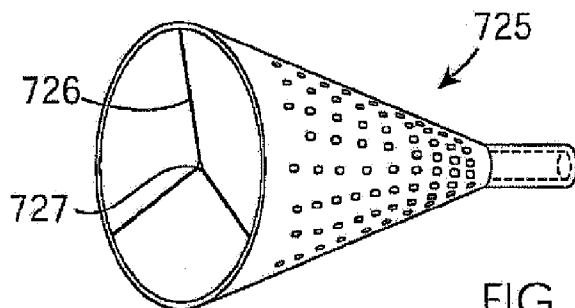

FIG. 172

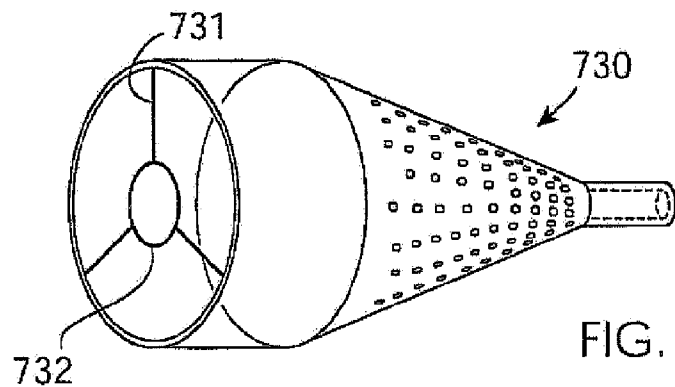
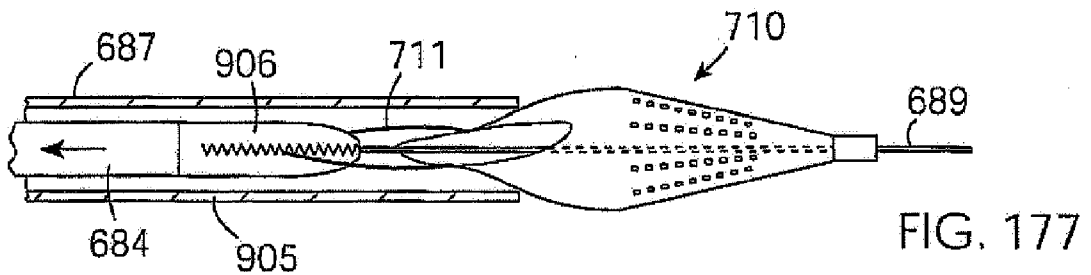
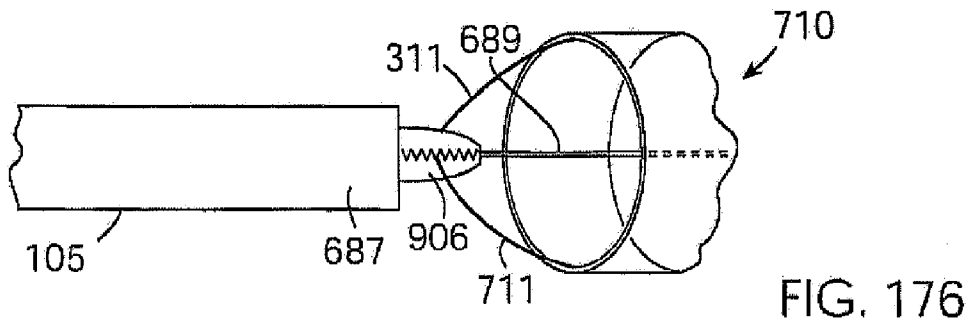
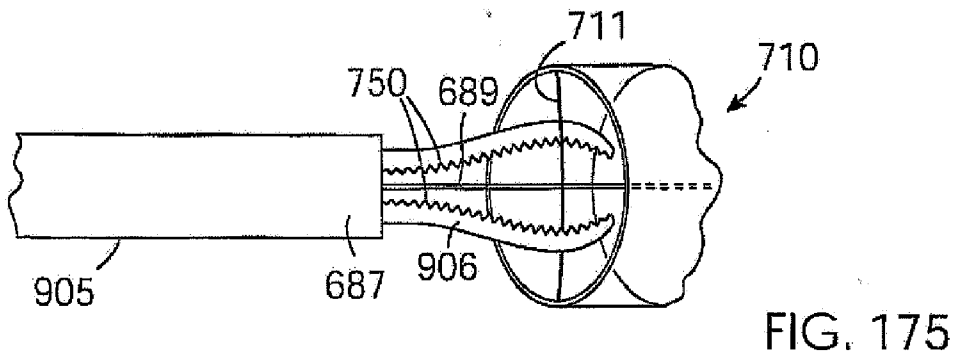
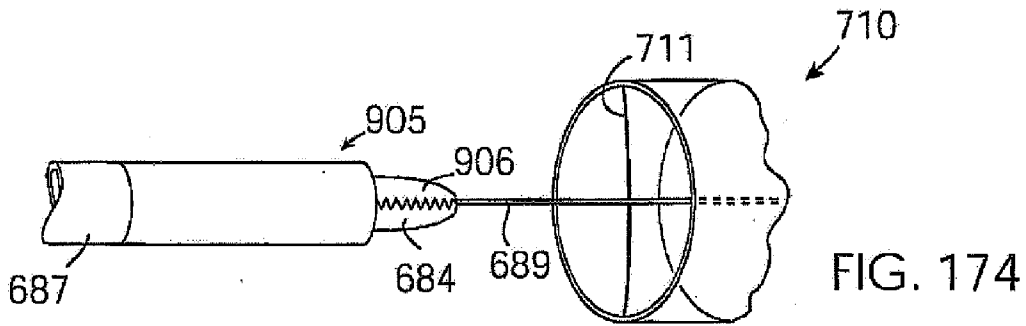

FIG. 173



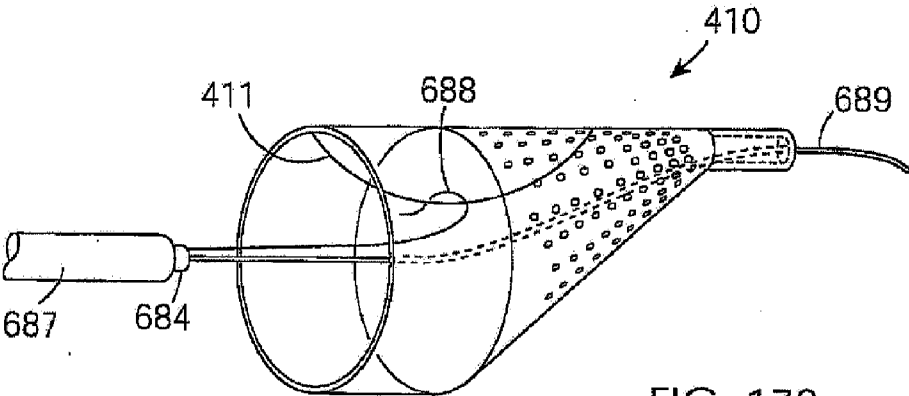

FIG. 179

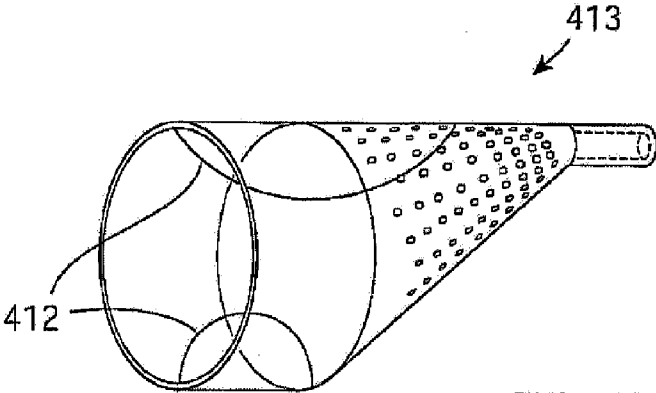
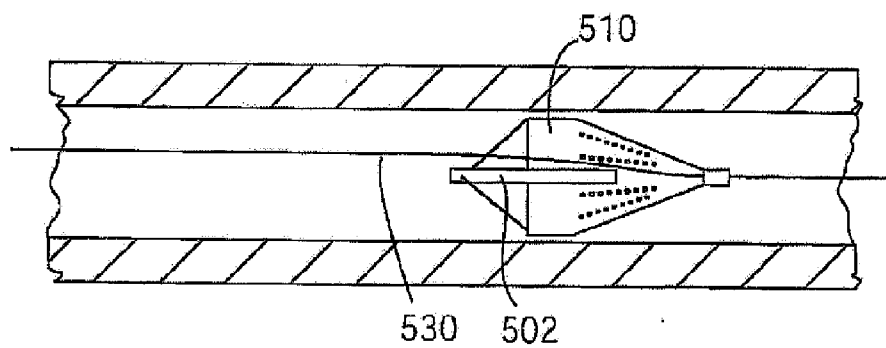
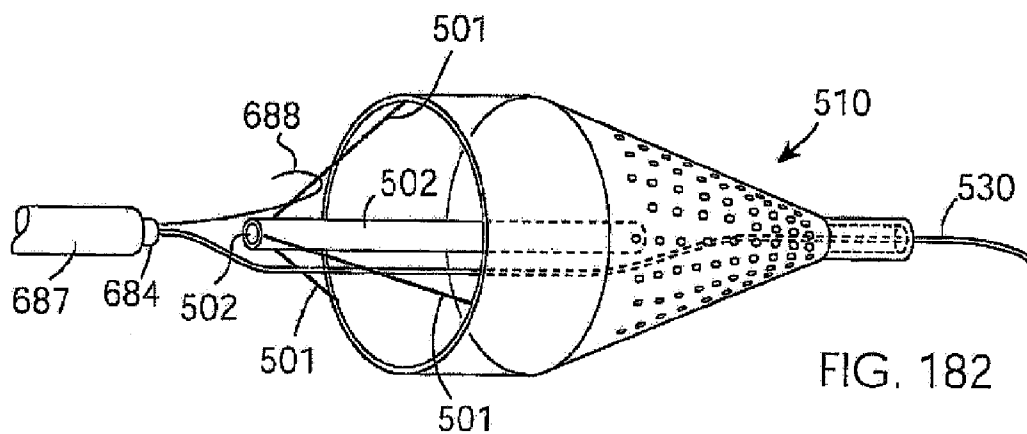
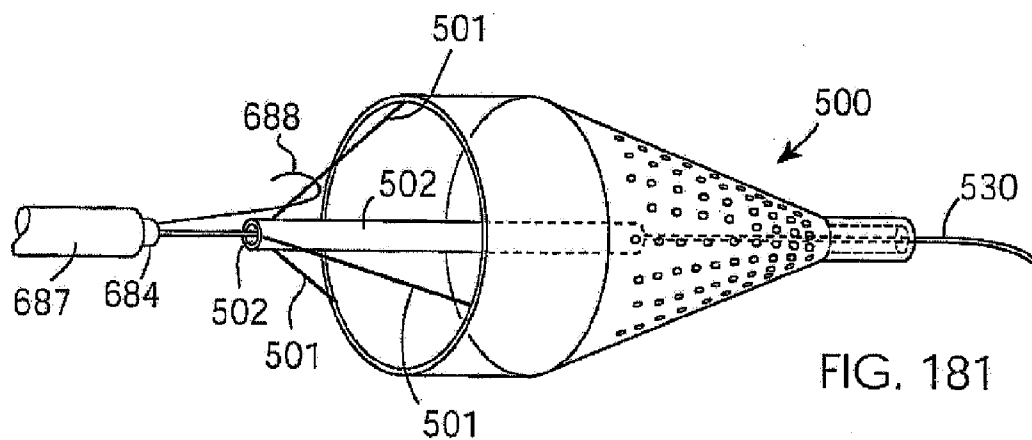

FIG. 180



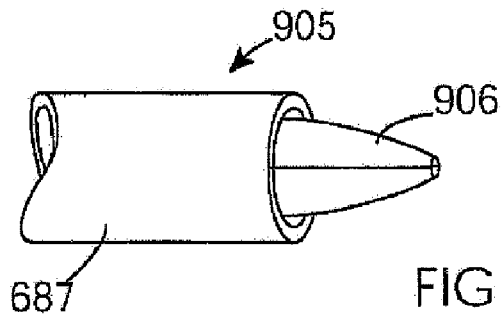

FIG. 184

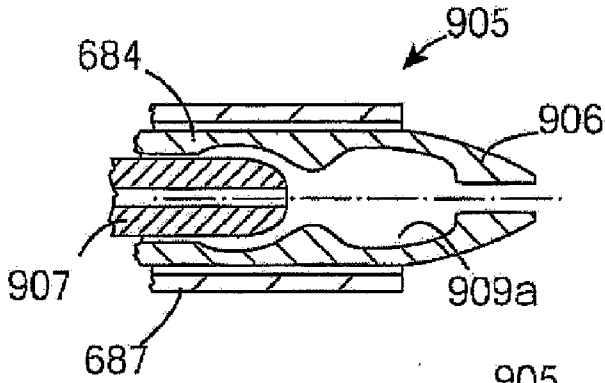

FIG. 185

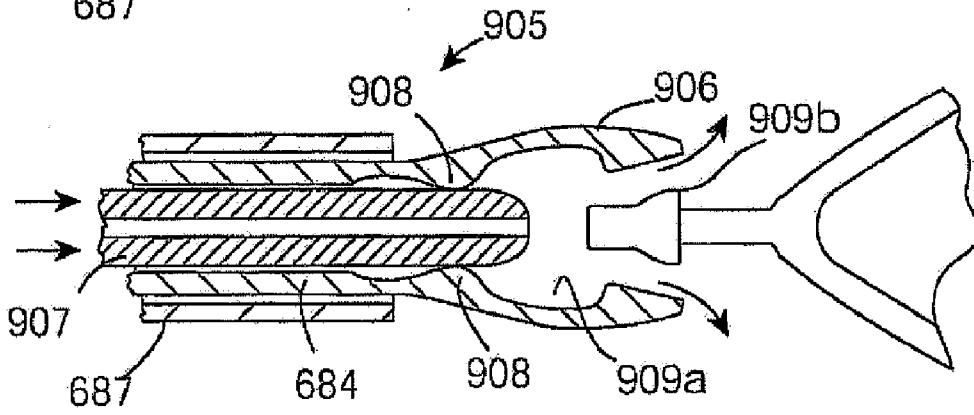

FIG. 186

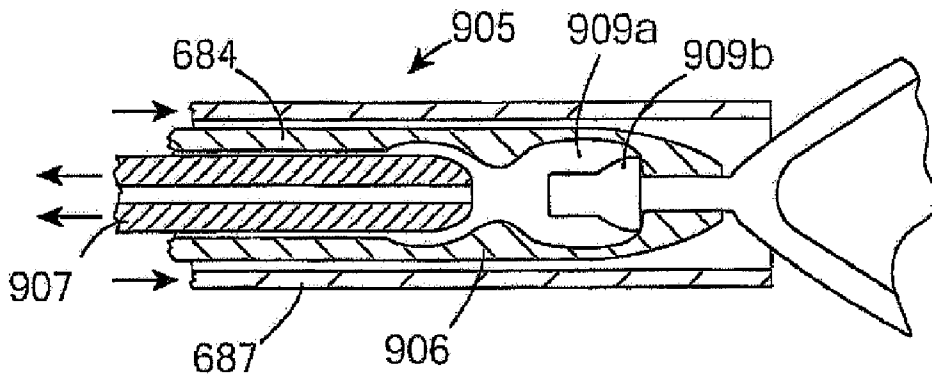

FIG. 187

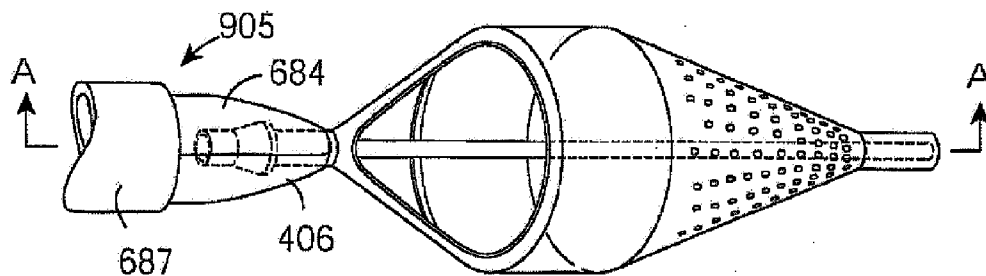

FIG. 188

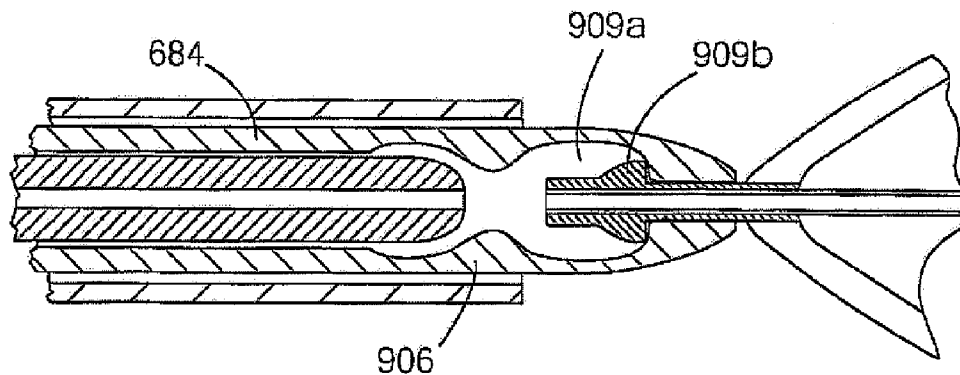

FIG. 189

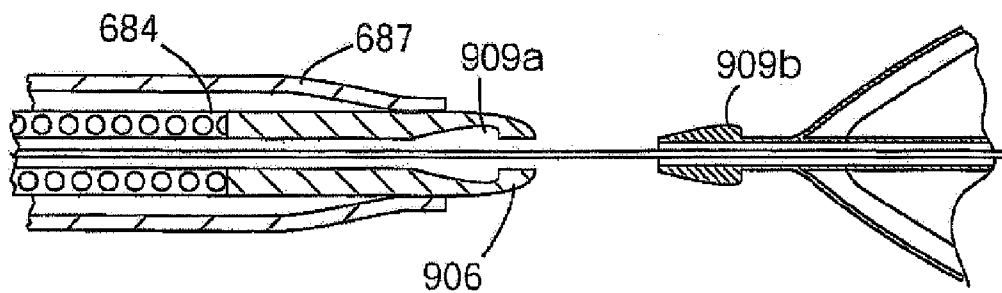

FIG. 190

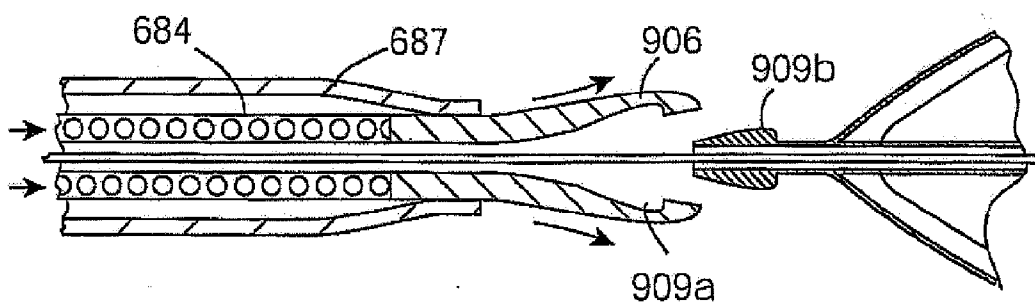

FIG. 191

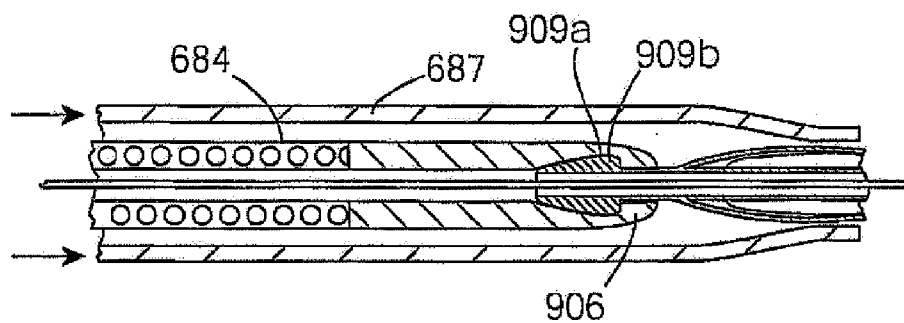

FIG. 192

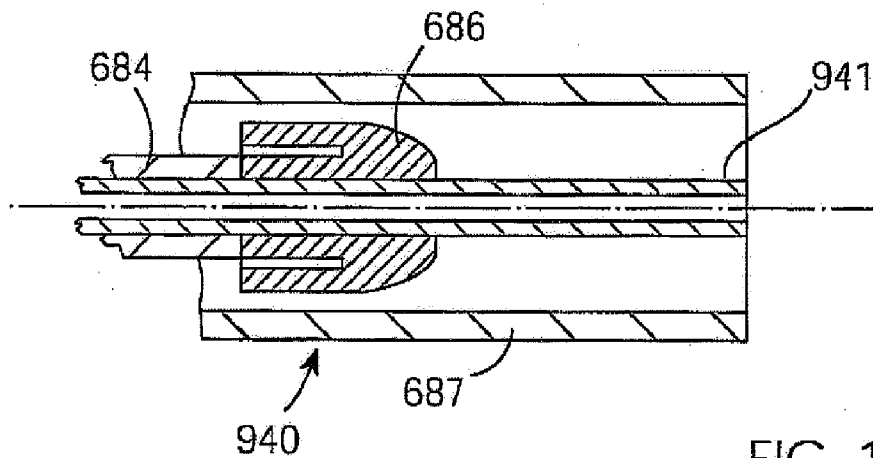

FIG. 193

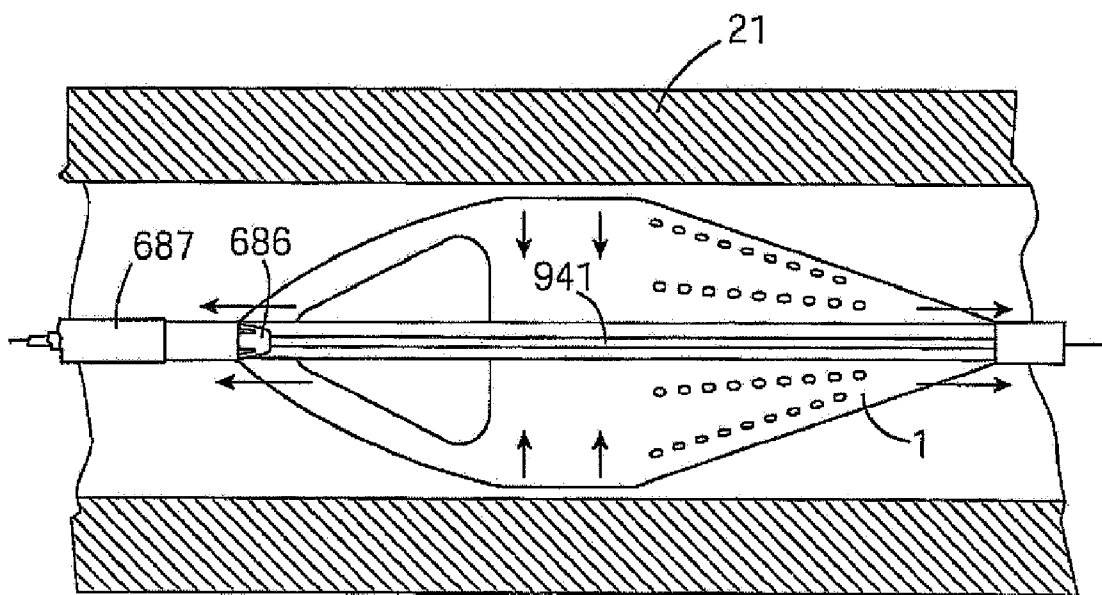

FIG. 194

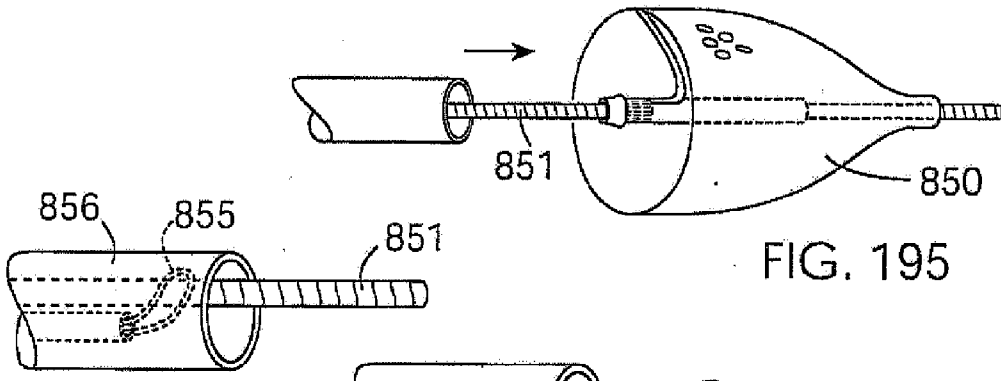

FIG. 195

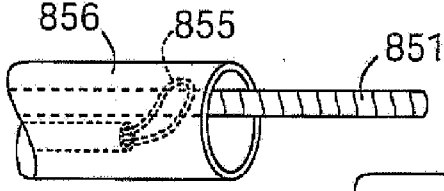

FIG. 196

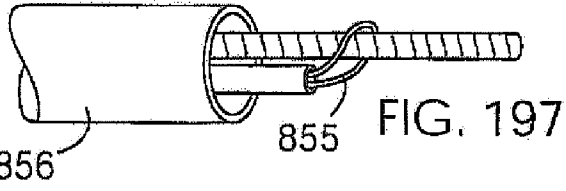

FIG. 197

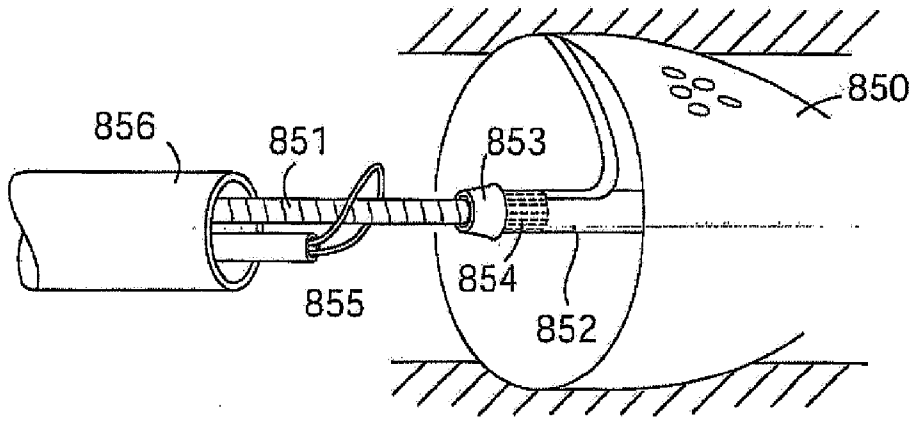

FIG. 198

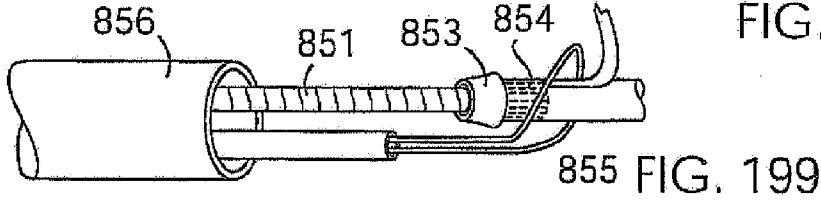

FIG. 199

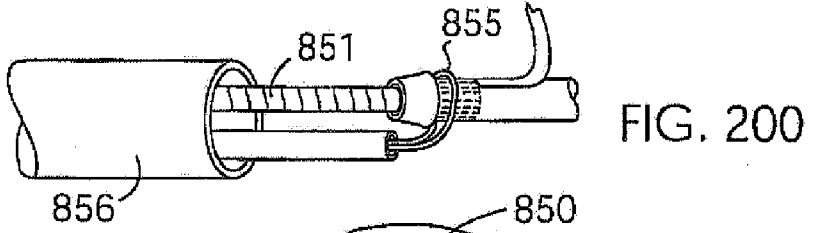

FIG. 200

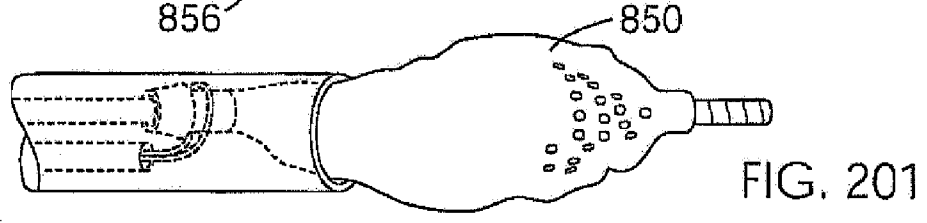
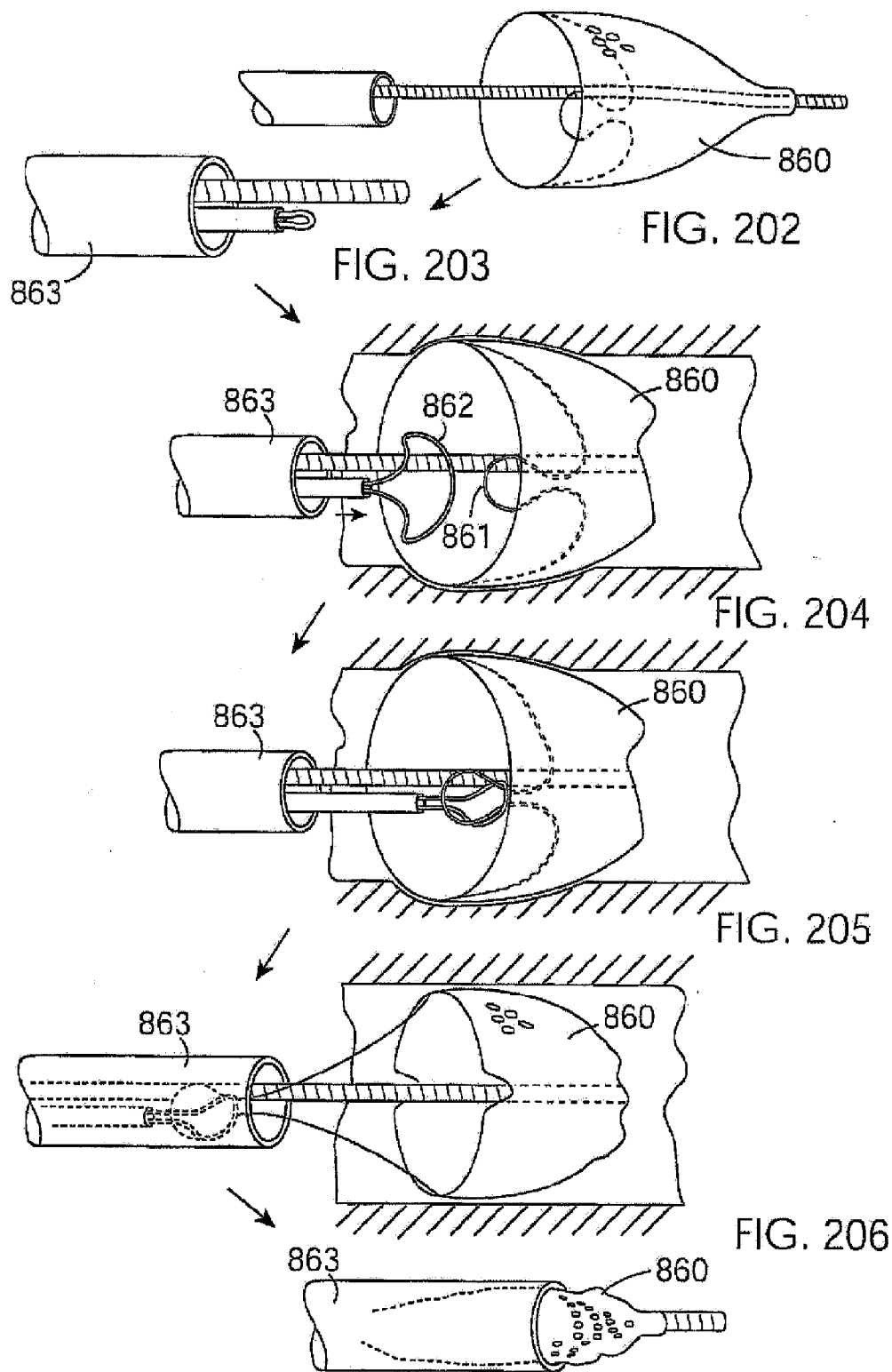
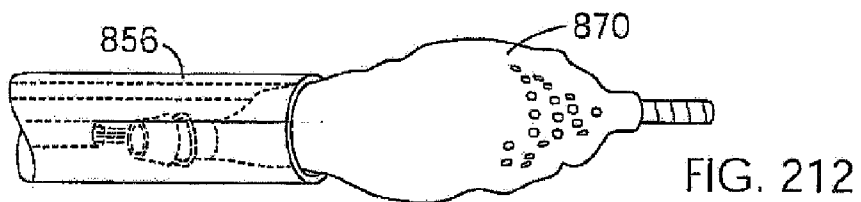
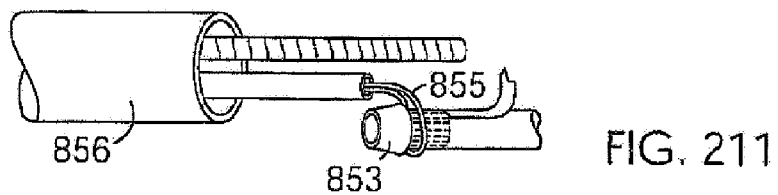
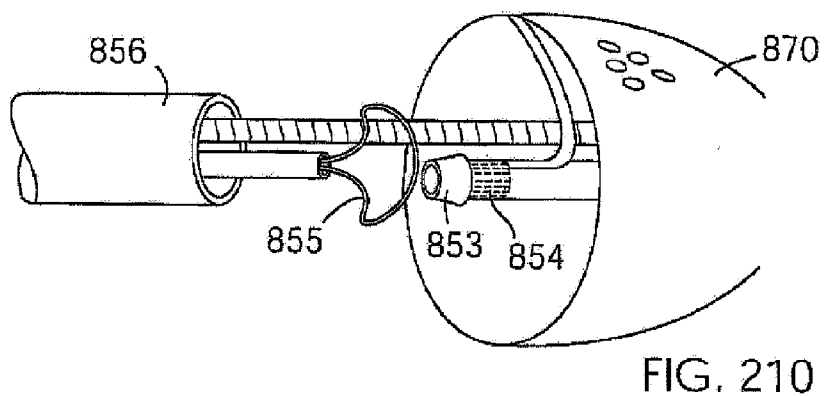
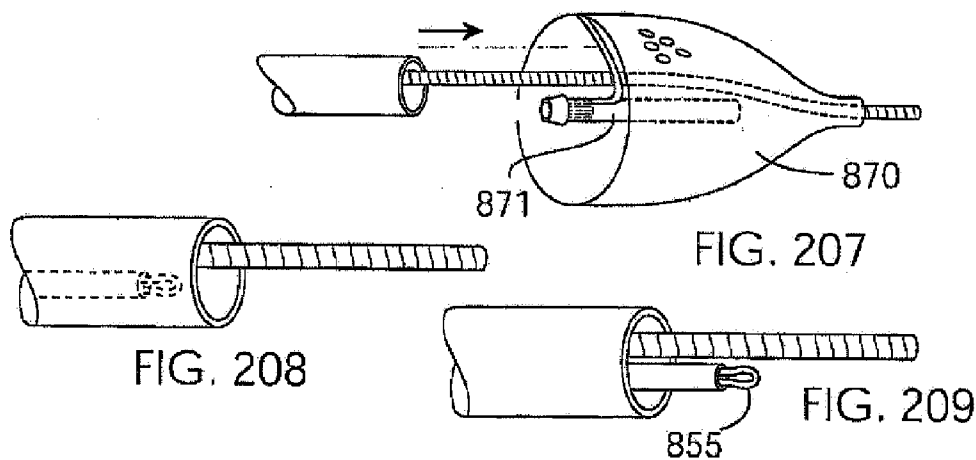
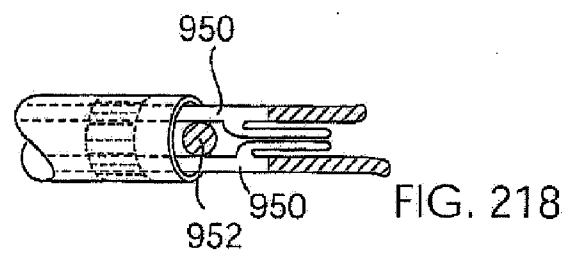
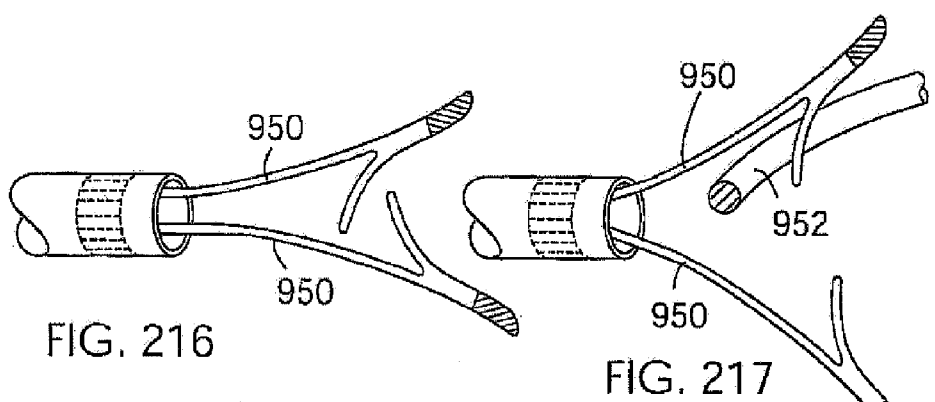
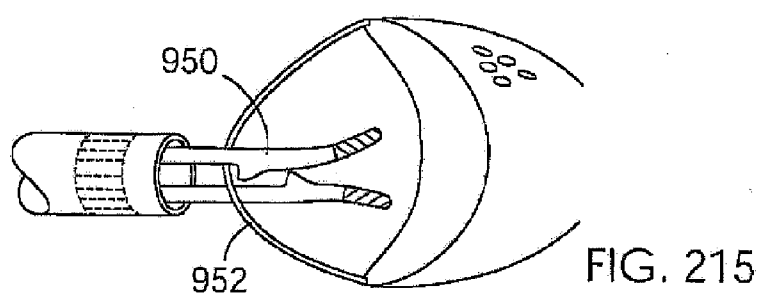
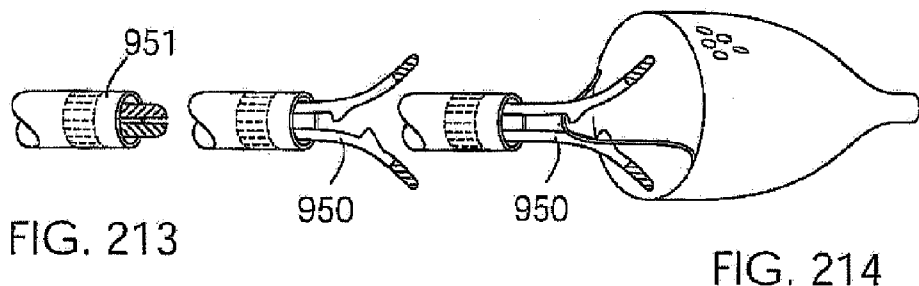

FIG. 201







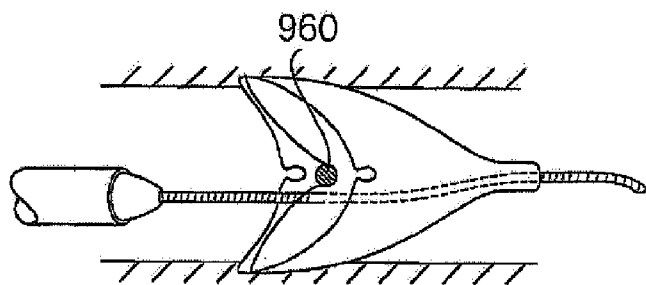

FIG. 219

FIG. 220

FIG. 221

FIG. 222

FIG. 223

FIG. 224

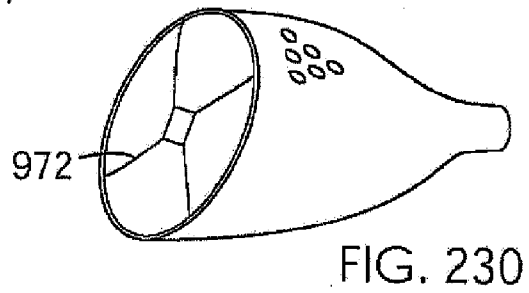
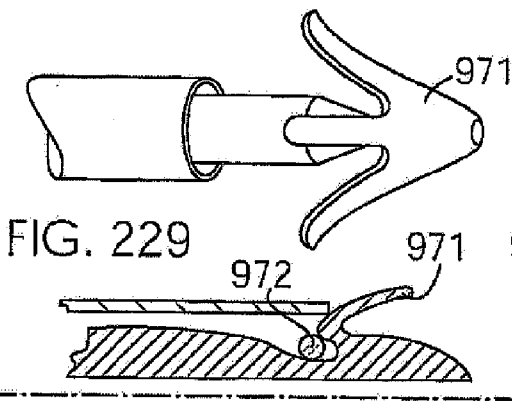
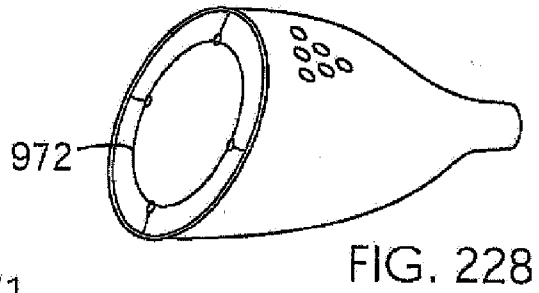
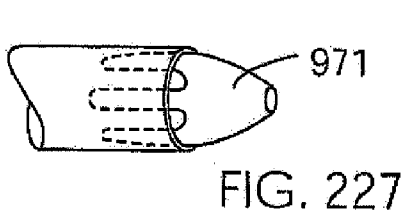
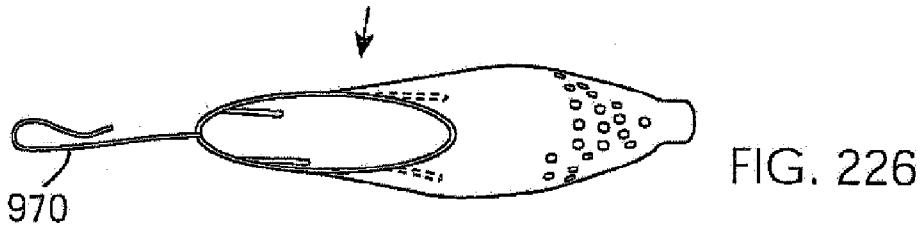
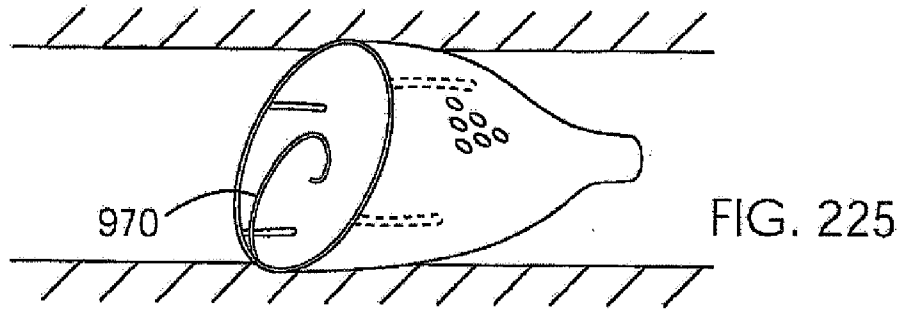
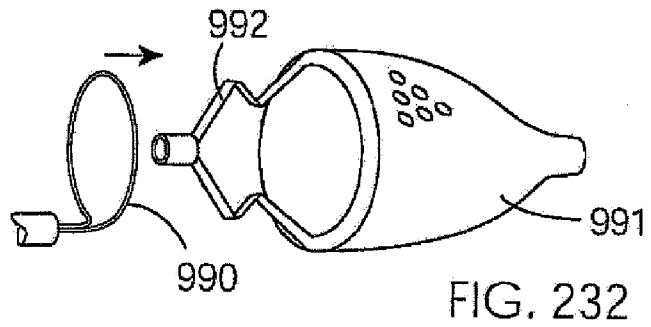
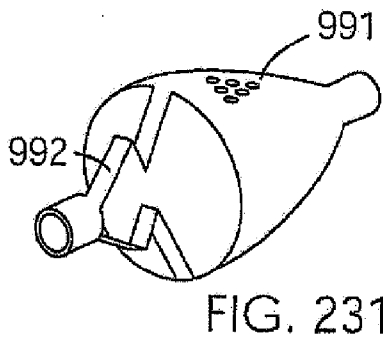
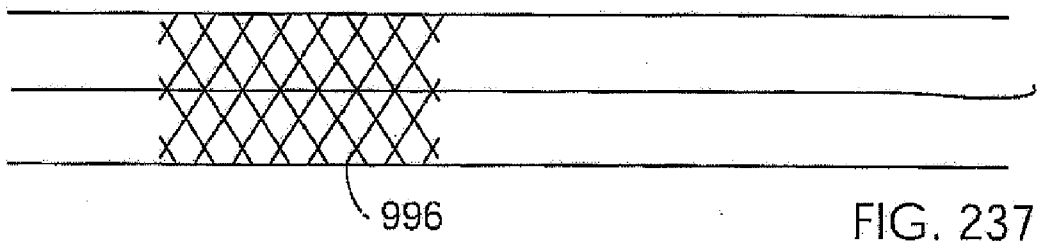
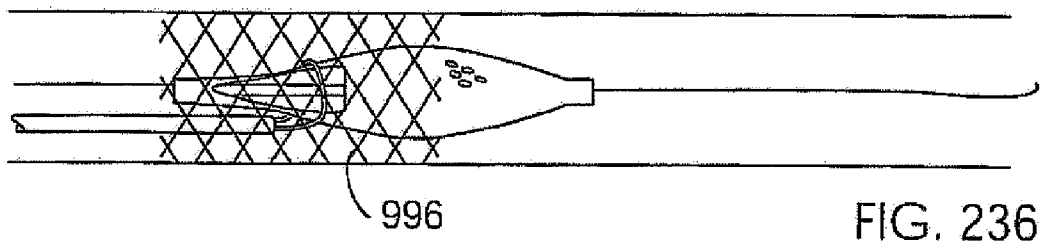
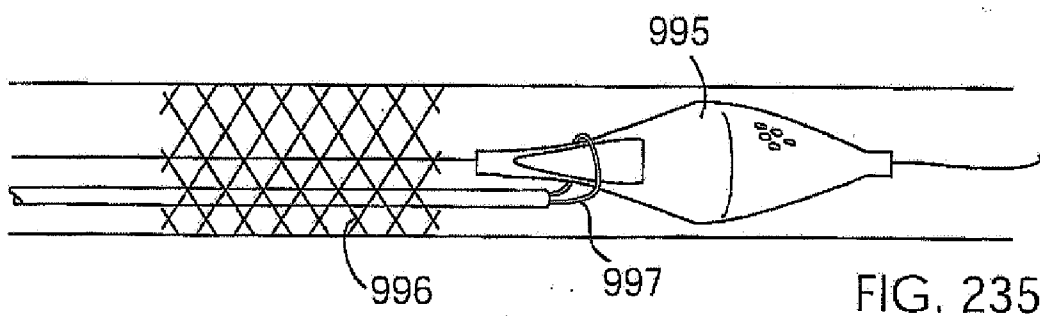
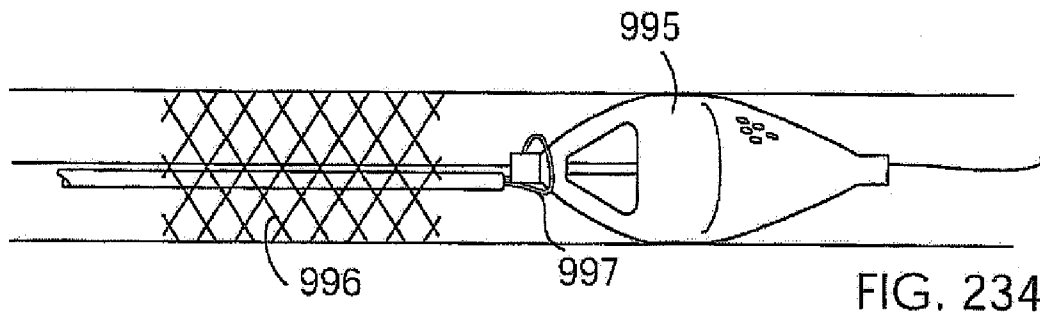
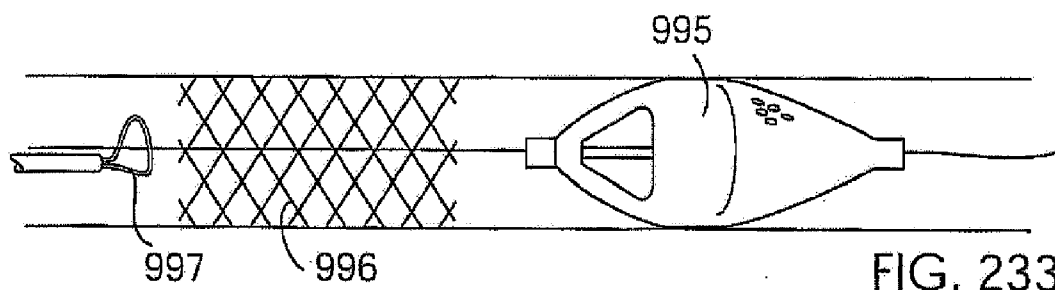

FIG. 229A





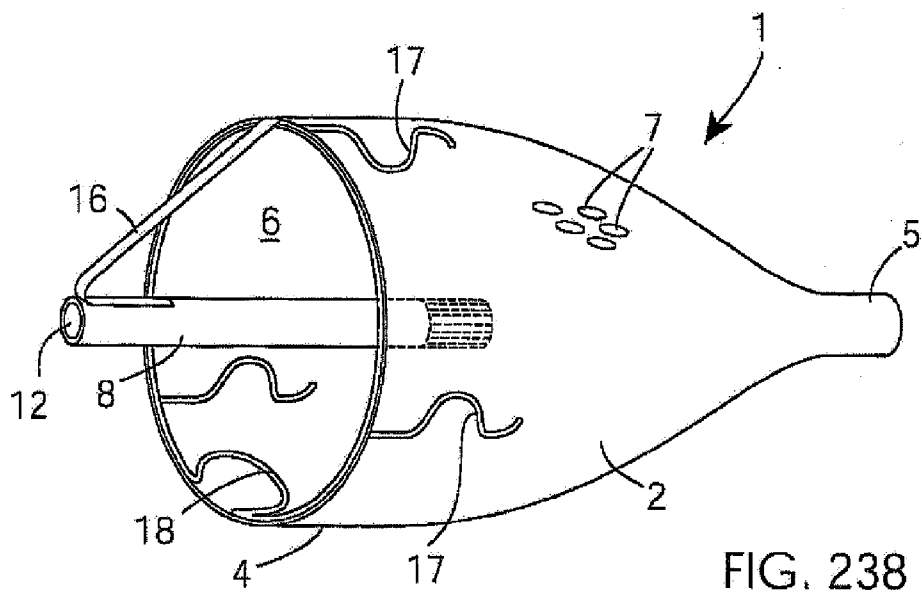

FIG. 238

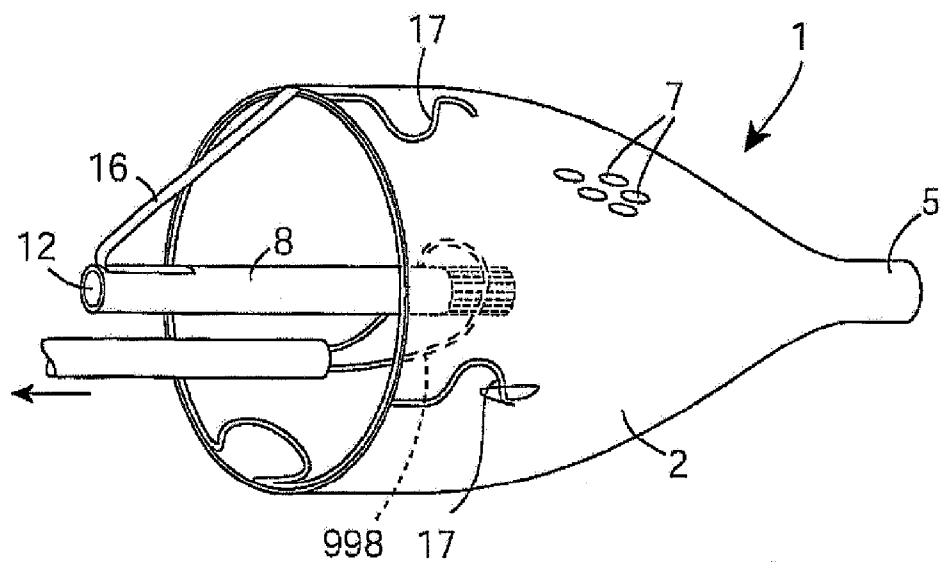

FIG. 239

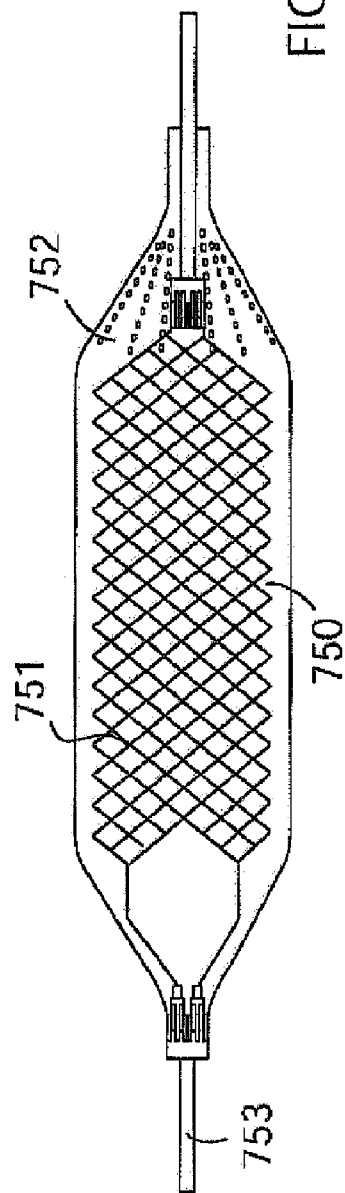

FIG. 240

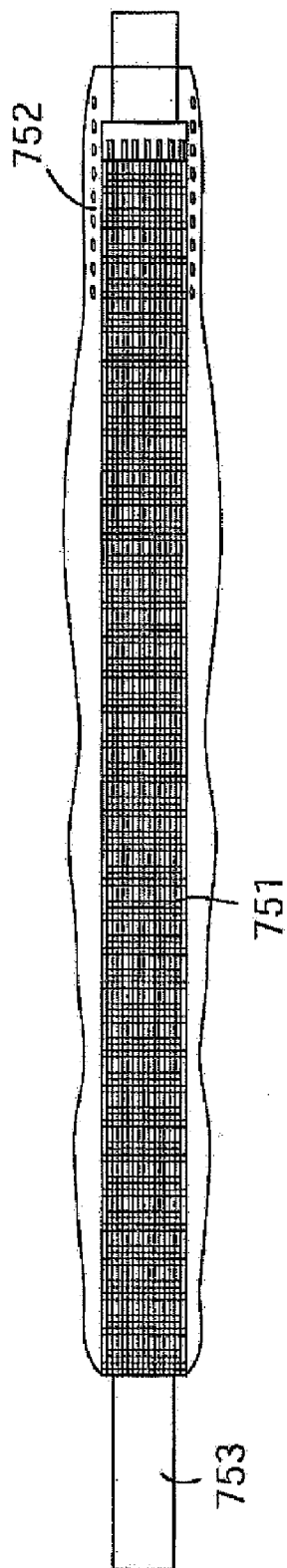

FIG. 241

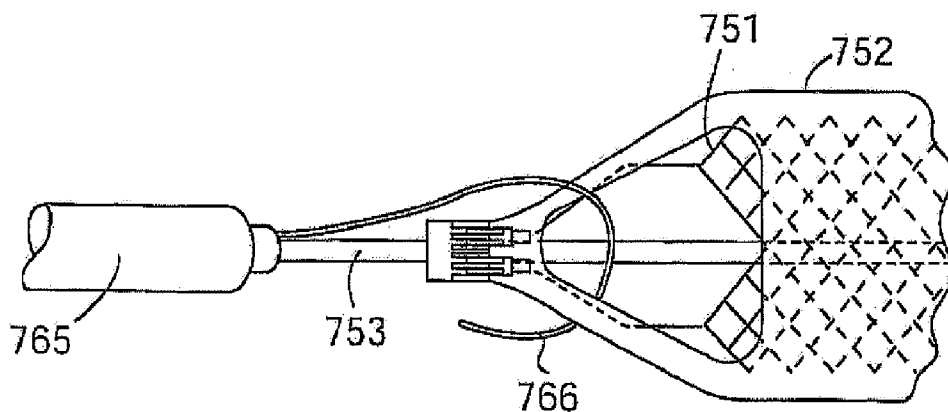

FIG. 242

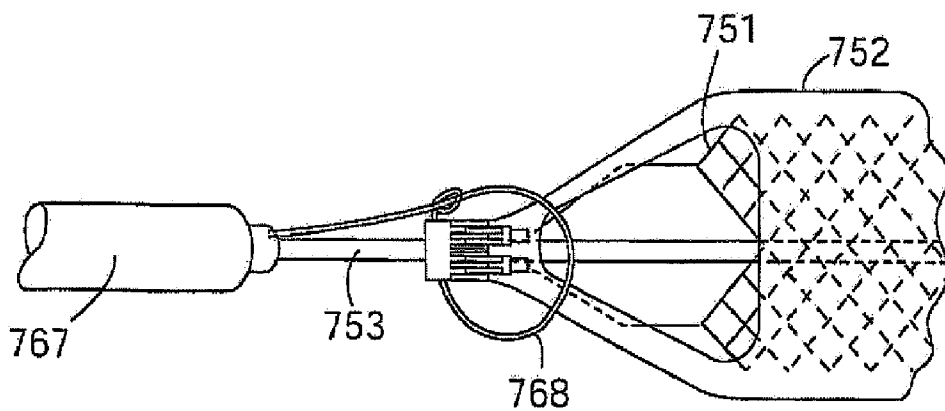
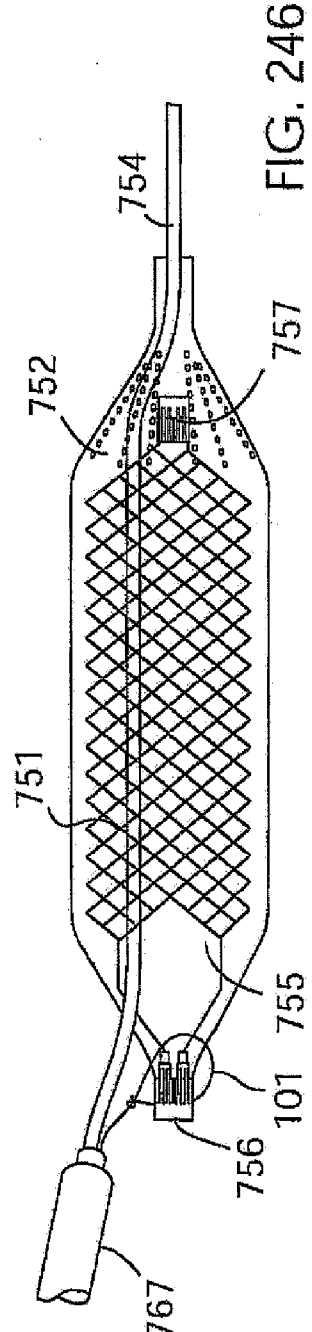
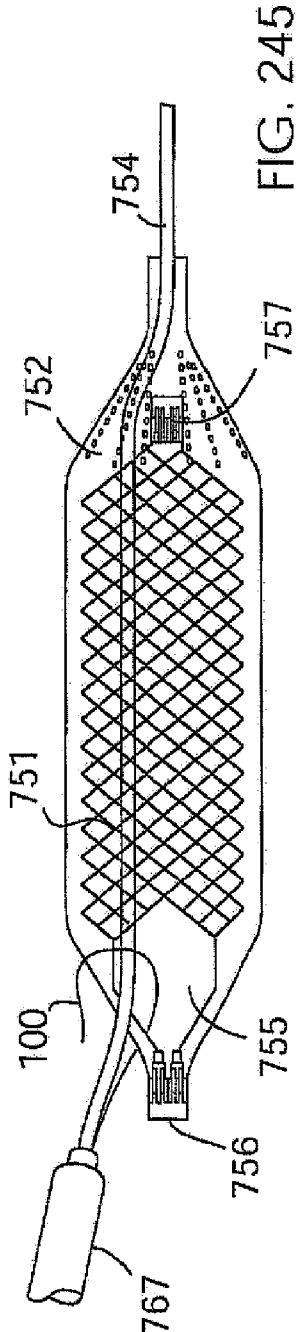
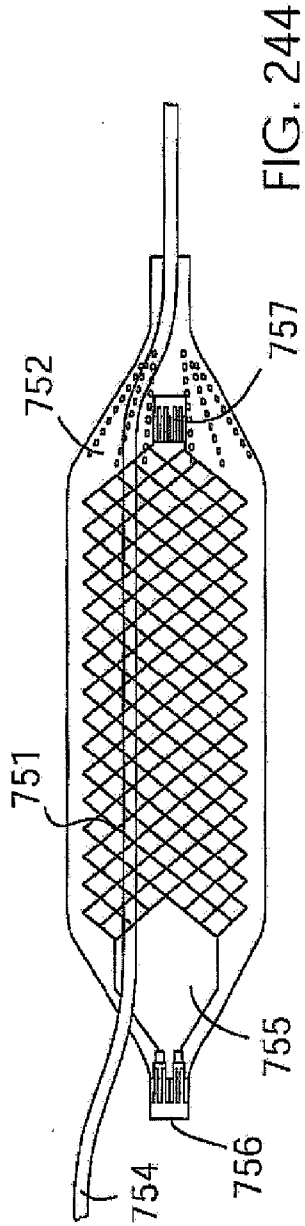

FIG. 243



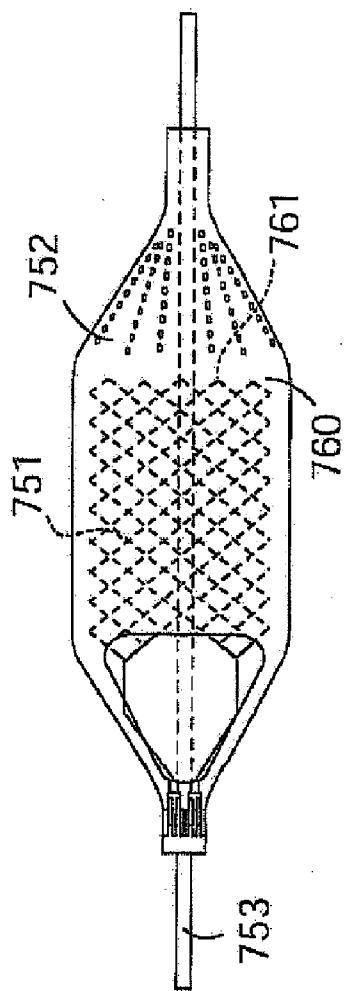

FIG. 247

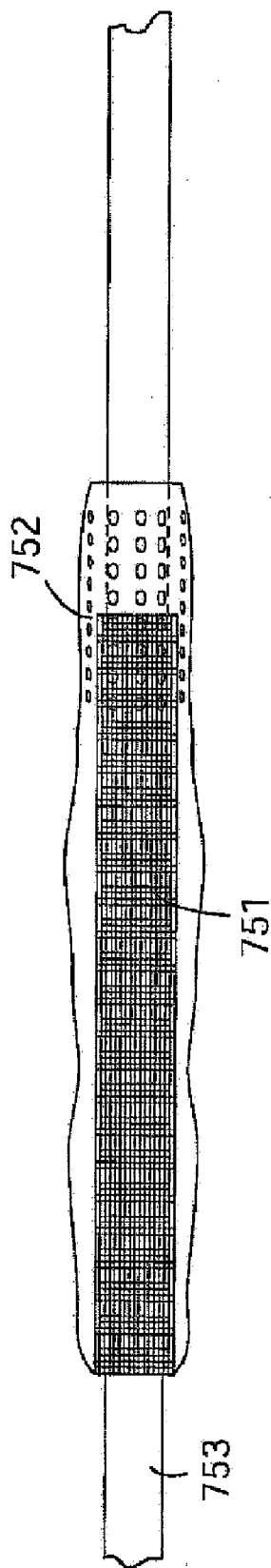

FIG. 248

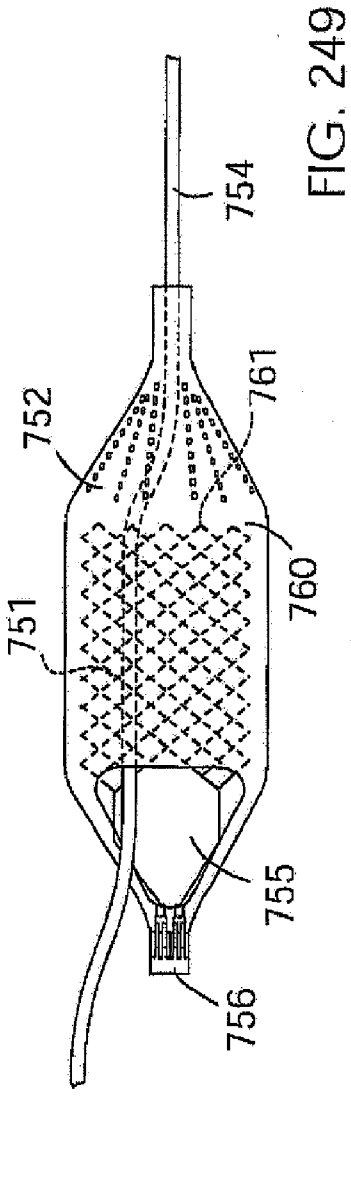

FIG. 249

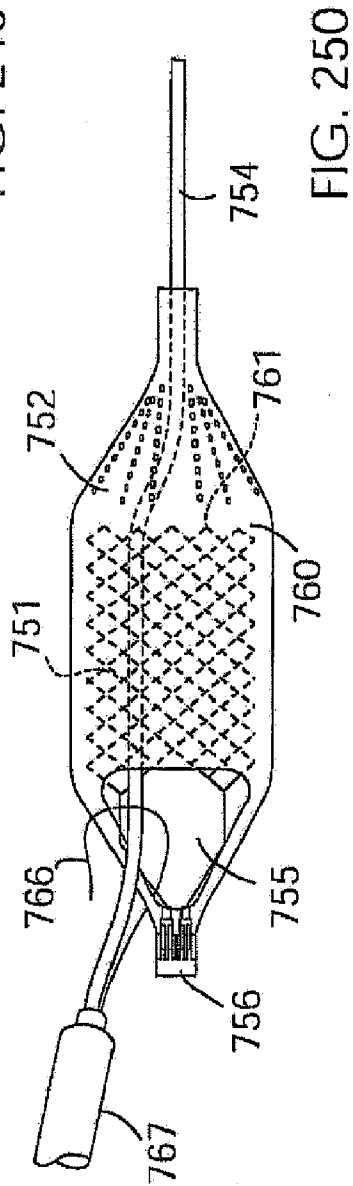

FIG. 250

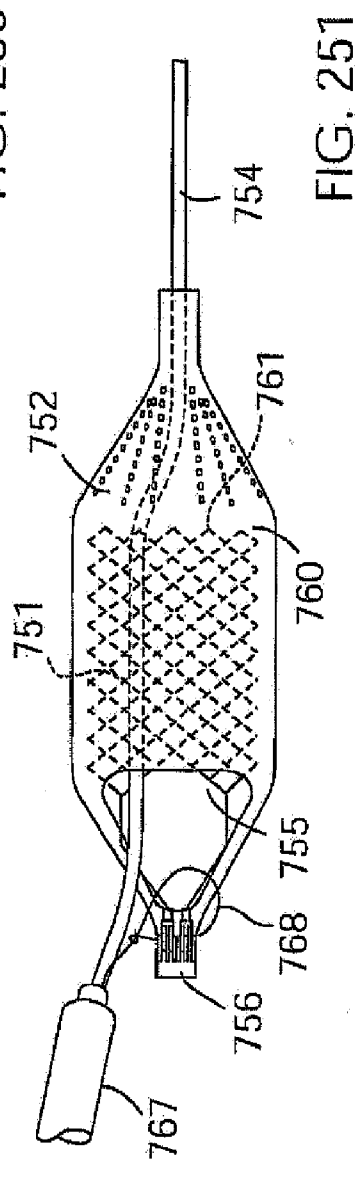

FIG. 251

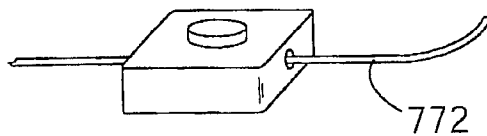

FIG. 252

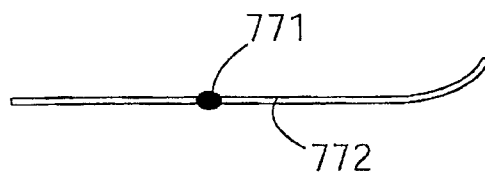

FIG. 256

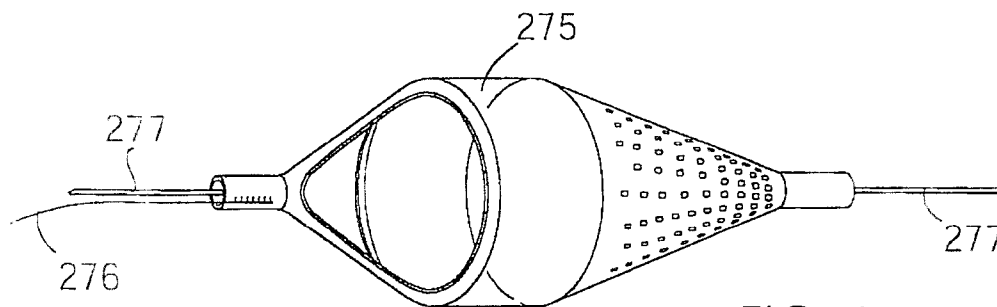

FIG. 257

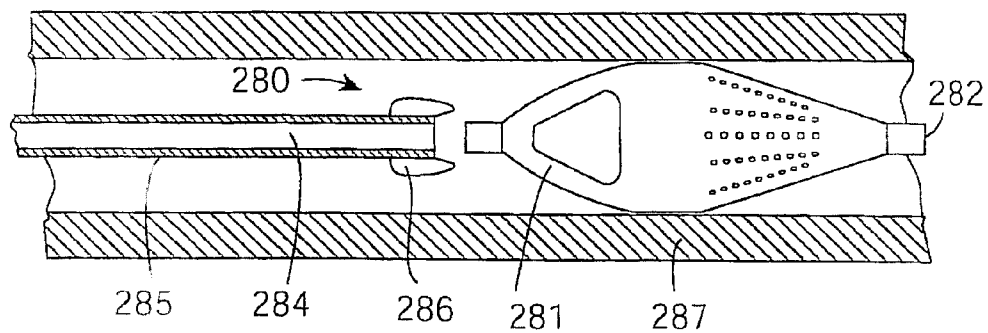

FIG. 258

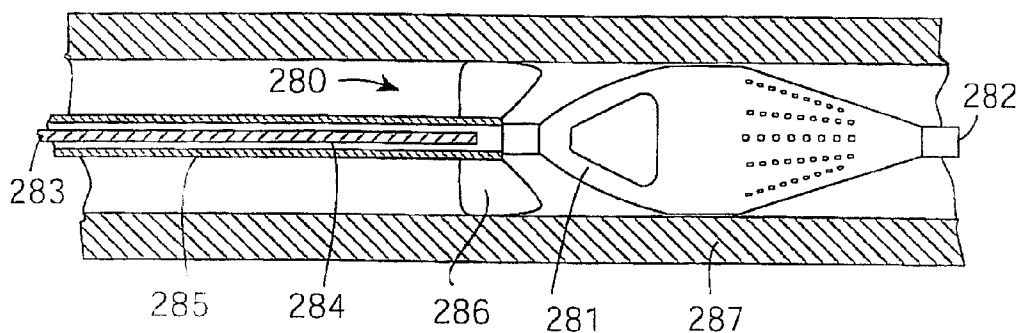

FIG. 259

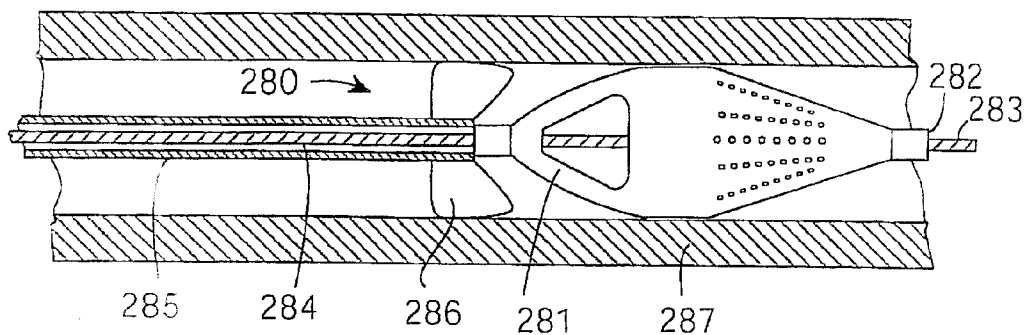

FIG. 260

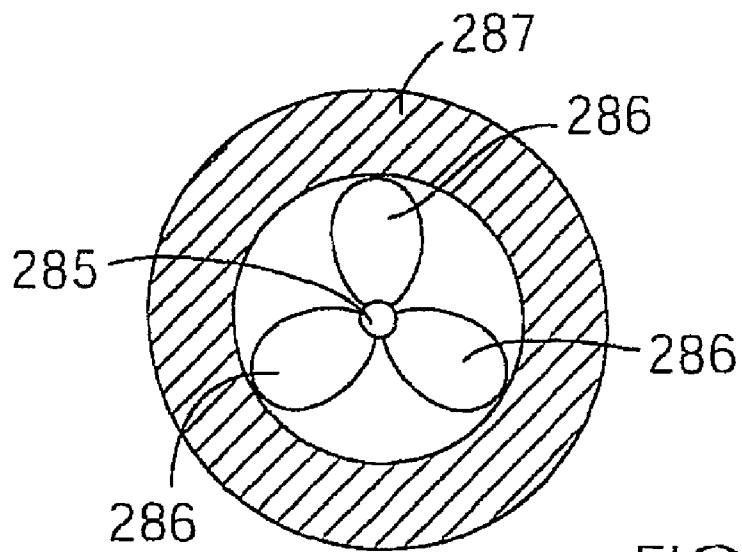

FIG. 261

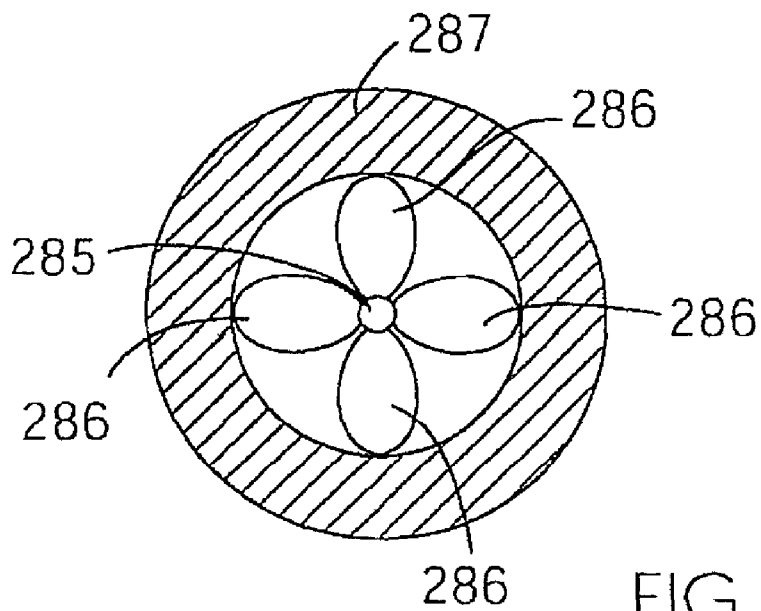

FIG. 262

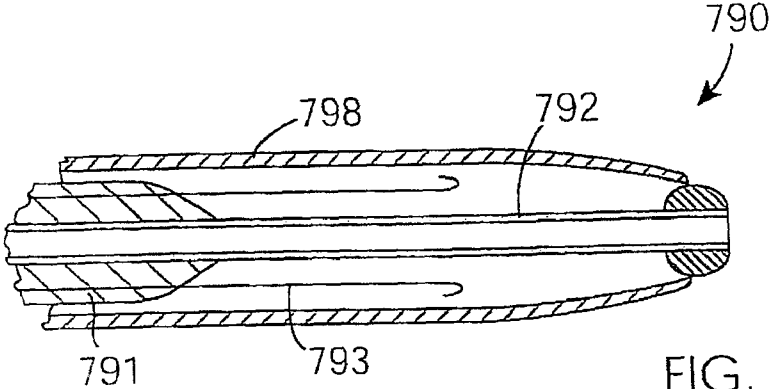

FIG. 263

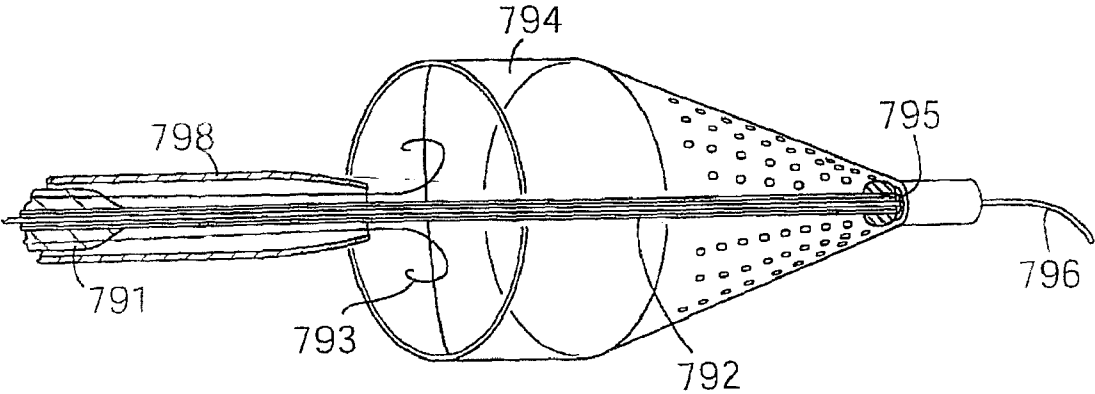

FIG. 264

EMBOLIC PROTECTION SYSTEM

[0001] This is a continuation of application Ser. No. 10/379,434 filed Mar. 5, 2003, which claims benefit of Provisional Application No. 60/361,340 filed Mar. 5, 2002. The entire disclosures of the prior application, application Ser. No. 10/379,434 is considered part of the disclosure of the accompanying continuation application and is hereby incorporated by reference.

INTRODUCTION

[0002] This invention relates to a transvascular embolic protection system for safely capturing and retaining embolic material released during an interventional procedure while maintaining blood flow.

[0003] Embolic protection systems of this general type are described in our published international patent applications WO 01/80776 and WO 01/80777.

[0004] There is an economical and clinical need to provide an embolic protection system which will be easy and convenient for a clinician to prepare for use, to deploy and to retrieve. In addition there is a need to provide such a system which is suitable for use with standard medical equipment and will facilitate a wide range of clinical procedures to be carried out.

Statements of Invention

[0005] According to the invention, there is provided an embolic protection filter for deployment in a vasculature, the filter having an inlet end and an outlet end, the inlet end having one or more inlet openings sized to allow blood and embolic material enter the filter, and the outlet end of the filter having a plurality of outlet openings sized to allow through passage of blood but to retain undesired embolic material within the filter;

[0006] the filter being movable between a collapsed configuration for movement through a vasculature, and an outwardly extended configuration for deployment in a vasculature;

[0007] the filter at least in the collapsed configuration having a guidewire lumen defined at least partially therethrough for passing the filter over a guidewire;

[0008] wherein the guidewire lumen is defined by a lumen-defining member which is movable or removable reactive to the filter.

[0009] In one embodiment, the lumen-defining member is a substantially tubular member.

[0010] In one embodiment, the tubular member has a slit extending the length thereof for removal of the member from a guidewire.

[0011] In another embodiment, the lumen-defining member comprises a portion of a delivery system.

[0012] Preferably the lumen-defining member comprises a pusher element of the delivery system, the pusher being movable from an extended lumen-defining configuration for loading of a filter to a retracted configuration for deployment of the filter.

[0013] According to another aspect of the invention, there is provided an embolic protection filter for deployment in a

vasculature, the filter having an inlet end and an outlet end, the inlet end having one or more inlet openings sized to allow blood and embolic material enter the filter, and the outlet end of the filter having a plurality of outlet openings sized to allow through passage of blood but to retain undesired embolic material within the filter;

[0014] the filter being movable between a collapsed configuration for movement through a vasculature, and an outwardly extended configuration for deployment in a vasculature in apposition with a vasculature wall;

[0015] in the outwardly extended configuration the filter exerting an outward radial force on a vasculature wall sufficient to retain the filter in position against substantial longitudinal movement.

[0016] In one embodiment, the filter comprises a filter body and a filter support frame to support the filter body in the outwardly extended configuration in apposition with a vasculature wall, the filter support frame providing the outward radial force.

[0017] In one embodiment, the filter comprises a low-friction outer layer.

[0018] Preferably the outer layer is of a hydrophilic material.

[0019] In one embodiment, the filter comprises an inflatable member to enhance the outward radial force.

[0020] In another embodiment, the filter defines a guidewire lumen for passing the filter over a guidewire.

[0021] In one embodiment, the filter comprises an anchor for fixing the filter to the vasculature in the deployed configuration.

[0022] In another embodiment, the filter comprises a filter body and a filter support frame to support the filter body in the deployed configuration.

[0023] In one embodiment, the support frame comprises the anchor.

[0024] In one embodiment, the filter body comprises the anchor.

[0025] In another embodiment, the anchor comprises a plurality of anchor elements.

[0026] In one embodiment, the anchor elements are spaced-apart circumferentially around the filter when the filter is in the deployed configuration.

[0027] In one embodiment, the support frame comprises at least one support hoop.

[0028] In another embodiment, the support frame has a longitudinal aspect,

[0029] In a further embodiment, the filter is self supported in a vasculature in the absence of a guidewire.

[0030] According to another aspect of the invention, there is provided an embolic protection filter assembly for deployment in a vasculature, the assembly comprising:

[0031] a filter having an inlet end and an outlet end, the inlet end having one or more inlet openings sized to allow blood and embolic material enter the filter, and the outlet end of the filter having a plurality of outlet

openings sized to allow through passage of blood but to retain undesired embolic material within the filter; and

[0032] a receiver to guide a docking device into association with the filter.

[0033] In one embodiment, the filter has a guidewire lumen for passing the filter over a guidewire, and the receiver is configured to guide a guidewire into the guidewire lumen.

[0034] In one embodiment, the guidewire lumen extends only partially through the filter.

[0035] In another embodiment, the receiver is configured to guide a coupling member towards the filter for coupling to the filter.

[0036] In one embodiment, the receiver comprises a funnel.

[0037] In another embodiment, the funnel is movable between a collapsed configuration for movement through a vasculature, and an outwardly extended configuration for guiding a docking device.

[0038] In one embodiment, the funnel is biased towards the outwardly extended configuration.

[0039] In another embodiment, the funnel comprises a funnel body and a funnel support to support the funnel body in the outwardly extended configuration.

[0040] In one embodiment, the funnel body comprises a membrane.

[0041] In a further embodiment, the funnel support comprises a plurality of pivotable fingers.

[0042] Preferably the receiver comprises an approach channel.

[0043] In one embodiment, the channel is provided by a lumen in a catheter.

[0044] In another embodiment, the receiver is mounted to the filter.

[0045] In one embodiment, the receiver is detachably mounted to the filter.

[0046] In another embodiment, the receiver is separate from the filter.

[0047] In a further embodiment, the receiver has means to space the receiver from the wall of a vasculature.

[0048] Preferably the spacing means comprises an inflatable member to engage the wall of a vasculature.

[0049] In one embodiment, the receiver is at least partially provided by a wall of the filter.

[0050] In another embodiment, the receiver is at least partially provided by a wall of the filter at the inlet end of the filter.

[0051] In a further embodiment, the receiver is at least partially provided by a wall of the filter at the outlet end of the filter.

[0052] In one embodiment, the receiver extends proximally of the inlet end of the filter.

[0053] In another embodiment, the receiver is located distally of the inlet end of the filter.

[0054] In a further embodiment, the receiver is radially offset from the longitudinal axis of the filter.

[0055] According to another aspect of the invention there is provided, an embolic protection system comprising:

[0056] an embolic protection filter assembly as claimed in any of claims 21 to 43; and

[0057] a docking device which may be guided by the receiver into association with the filter.

[0058] In one embodiment, the docking device comprises a guidewire.

[0059] In one embodiment, the docking device comprises a coupling member.

[0060] According to another aspect of the invention, there is provided an embolic protection filter having an inlet end and an outlet end, the inlet end having one or more inlet openings sized to allow blood and embolic material enter the filter, and the outlet end of the filter having a plurality of outlet openings sized to allow through passage of blood but to retain undesired embolic material within the filter;

[0061] the filter having a guidewire aperture for passing the filter over a guidewire; and

[0062] the filter comprising a seal to seal the guidewire aperture.

[0063] Preferably the seal is self-closing.

[0064] In one embodiment, the seal is located at a proximal end of the filter, and/or at a distal end of the filter.

[0065] In one embodiment, the filter has a tubular member extending from the guidewire aperture to define a guidewire lumen through the tubular member.

[0066] In another embodiment, the tubular member extends through at least part of the filter.

[0067] In one embodiment, the tubular member is radially offset from the longitudinal axis of the filter.

[0068] In one embodiment, the seal is an annular member around the guidewire aperture, the annular member being closable down to seal the guidewire aperture.

[0069] Preferably the annular member is a tube.

[0070] In one embodiment, the annular member comprises a soft membrane.

[0071] In one embodiment, the annular member comprises two or more circumferentially overlapping flaps.

[0072] According to a further aspect of the invention, there is provided a retrieval catheter for retrieving a medical device deployed in a vasculature, the catheter comprising:

[0073] an outer catheter body; and

[0074] an inner coupling member having means for coupling to a medical device deployed in a vasculature;

[0075] the catheter body being movable distally relative to the coupling member to retrieve a coupled medical device into the catheter body.

[0076] In one embodiment, the coupling means comprises a male or female member on the coupling member for engagement with a corresponding female or male member on the medical device.

[0077] In one embodiment, the male member is movable between a low-profile configuration and an outwardly protruding configuration.

[0078] In one embodiment, the male member is biased towards the outwardly protruding configuration.

[0079] In another embodiment the male member is of a resilient material.

[0080] Preferably the coupling means is substantially arrow-head shaped.

[0081] In one embodiment, the male member is in the form of a hook for hooking around a female member on the medical device.

[0082] In one embodiment, the male member is in the form of a hook for hooking around a tether arm on the medical device.

[0083] In one embodiment, the tether arm is at a proximal end of the medical device.

[0084] In another embodiment, the tether arm is located within the medical device.

[0085] In one embodiment, the coupling means comprises at least one female member on the coupling member for engagement with at least one male member on the medical device.

[0086] In one embodiment, the female member is in the form of a loop for looping around a protruding male member on the medical device.

[0087] In one embodiment, the coupling means comprises a pair of jaws on the coupling member, the jaws being movable between an outwardly protruding configuration and a low-profile configuration to grasp the medical device.

[0088] In one embodiment, the retrieval catheter comprises an actuator to move the jaws to the outwardly protruding configuration.

[0089] In another embodiment, the actuator is movable longitudinally relative to the jaws to move the jaws in a camming arrangement to the outwardly protruding configuration.

[0090] In a further embodiment, the jaws are biased towards the low-profile configuration.

[0091] In one embodiment, the catheter body is engageable with the jaws to move the jaws to the low-profile configuration.

[0092] In another embodiment, the jaws are biased towards the outwardly protruding configuration.

[0093] In a further embodiment, the coupling member is at least partially of a magnetic material for magnetic coupling to an oppositely charged magnetic portion of the medical device.

[0094] In one embodiment, the retrieval catheter comprises means to axially elongate a deployed medical device

to collapse the medical device to a low-profile configuration for retrieval into the catheter body.

[0095] In one embodiment, the elongation means comprises a second coupling member movable relative to the first coupling member to collapse the medical device.

[0096] In another embodiment, the second coupling member comprises a pusher member movable distally relative to first coupling member to engage a deployed medical device distally of the first coupling means and thereby collapse the medical device.

[0097] In a further embodiment, the catheter body has a guidewire lumen extending partially therethrough for passing the catheter body over a guidewire in a rapid exchange manner.

[0098] In one embodiment, the guidewire lumen is offset radially from the coupling member.

[0099] According to one embodiment, there is provided a retrieval catheter for retrieving an embolic protection filter deployed in a vasculature.

[0100] In another aspect of the invention there is provided an embolic protection filter for deployment in a vasculature, the filter having an inlet end and an outlet end, the inlet end having one or more inlet openings sized to allow blood and embolic material enter the filter, and the outlet end of the filter having a plurality of outlet openings sized to allow through passage of blood but to retain undesired embolic material within the filter;

[0101] the filter being movable between a collapsed configuration for movement through a vasculature, and an outwardly extended configuration for deployment in a vasculature;

[0102] the filter at least in the collapsed configuration having a guidewire lumen defined at least partially therethrough for passing the filter over a guidewire;

[0103] wherein the guidewire lumen is defined by a lumen-defining member which is spaced proximally of the distal end of the filter.

[0104] In one embodiment, the guidewire lumen is defined by a tubular member.

[0105] In another embodiment, the tubular member is mounted to the filter.

[0106] Preferably the filter comprises a snare engaging feature.

[0107] Preferably the snare engaging feature is radiopaque.

[0108] In another aspect the invention provides a method for the capture and removal of embolic material from a vasculature during an interventional procedure comprising the steps of:

[0109] providing a collapsible embolic protection filter having a collapsed configuration for delivery of the filter, and a deployed configuration;

[0110] advancing a guidewire through a vasculature;

[0111] crossing a desired treatment location with the guidewire;

- [0112] deploying the filter distal to the treatment location;
- [0113] carrying out an interventional procedure at the treatment location, embolic material generated during the treatment procedure being captured by the deployed filter;
- [0114] advancing a retrieval device;
- [0115] engaging the filter with the retrieval device independent of the guidewire; and
- [0116] withdrawing the retrieval device and the filter from the vasculature.
- [0117] In one case, after crossing a treatment location with the guidewire the embolic protection device is introduced over the guidewire.
- [0118] In one case, the deployed filter is retained independent of the guidewire against substantial longitudinal movement.
- [0119] In another case, the filter applies a radial force to the vasculature to substantially prevent movement of the filter relative to the vasculature in the deployed configuration.
- [0120] In one case, the filter in the deployed configuration is anchored to the vasculature.
- [0121] In one case, the method comprises the step of releasing the filter from the vasculature before retrieving the filter.
- [0122] In another case, the filter is simultaneously released and retrieved by moving a retrieval catheter distally relative to the filter.
- [0123] In one case the filter is released prior to retrieving the filter.
- [0124] In one case, the method comprises the step of axially elongating the filter to release the filter.
- [0125] According to another aspect the method comprises the steps of:
- [0126] withdrawing the guidewire from the filter and/or the desired treatment location; and
- [0127] subsequently placing a guidewire in the filter.
- [0128] In one case, the same guidewire is placed in the filter.
- [0129] In another case, another guidewire is placed in the filter.
- [0130] In one case, the interventional device is introduced over the guidewire for carrying out the interventional procedure.
- [0131] In one case, the interventional procedure comprises a stenting of the treatment location.
- [0132] In another case, the interventional procedure comprises a balloon angioplasty procedure at the treatment location.
- [0133] According to another aspect the invention provides a method for the capture and removal of embolic material from a vasculature during an interventional procedure comprising the steps of:
- [0134] advancing a guidewire through a vasculature;
- [0135] crossing a desired treatment location with the guidewire;
- [0136] introducing over the guidewire a collapsible embolic protection filter having a collapsed configuration for delivery of the filter, and a deployed configuration;
- [0137] deploying the filter distal to the treatment location;
- [0138] the filter in the deployed configuration being retained in apposition with the vasculature independent of the guidewire against substantial longitudinal movement;
- [0139] carrying out an interventional procedure at the treatment location, embolic material generated during the treatment procedure being captured by the deployed filter;
- [0140] advancing a retrieval device;
- [0141] engaging the filter with the retrieval device; and
- [0142] withdrawing the retrieval device and the filter from the vasculature.
- [0143] In one case, on the filter applies a radial force to the vasculature to substantially prevent movement of the filter relative to the vasculature in the deployed configuration.
- [0144] Preferably the filter in the deployed configuration is anchored to the vasculature.
- [0145] In one case, the filter is engaged with the retrieval device independent of the guidewire.
- [0146] According to another aspect the method comprises the step of releasing the filter from the vasculature before retrieving the filter.
- [0147] According to a further aspect, the retrieval device is a retrieval catheter and the filter is simultaneously released and retrieved by moving the retrieval catheter distally relative to the filter.
- [0148] In one case, the filter is released prior to retrieving the filter.
- [0149] According to one aspect, the method comprises the step of axially elongating the filter to release of the filter.
- [0150] Preferably the method comprises the steps of:
- [0151] withdrawing the guidewire from the filter and the desired treatment location; and
- [0152] subsequently placing a guidewire in the filter.
- [0153] According to a one aspect, the same guidewire is placed in the filter.
- [0154] According to a another aspect, another guidewire is placed in the filter.
- [0155] In one case, the interventional device is introduced over the guidewire for carrying out the interventional procedure.
- [0156] Preferably the interventional procedure comprises a stenting of the treatment location.

[0157] According to one aspect, the interventional procedure comprises a balloon angioplasty procedure at the treatment location.

[0158] According to a further aspect a method for the capture and removal of embolic material from a vasculature during an interventional procedure comprising the steps of:

[0159] providing a collapsible embolic protection filter having a collapsed configuration for delivery of the filter, and a deployed configuration;

[0160] advancing a guidewire through a vasculature;

[0161] crossing a desired treatment location with the guidewire;

[0162] deploying the filter distal to the treatment location;

[0163] withdrawing the guidewire from the filter and/or the desired treatment location; and

[0164] subsequently placing a guidewire in the filter;

[0165] carrying out an interventional procedure at the treatment location, embolic material generated during the treatment procedure being captured by the deployed filter;

[0166] advancing a retrieval device;

[0167] engaging the filter with the retrieval device; and

[0168] withdrawing the retrieval device and the filter from the vasculature.

[0169] In one case, the same guidewire is placed in the filter.

[0170] In another case, another guidewire is placed in the filter.

[0171] In one case the interventional device is introduced over the guidewire for carrying out the interventional procedure.

[0172] In another case, the interventional procedure comprises a stenting of the treatment location.

[0173] In one case, the interventional procedure comprises a balloon angioplasty procedure at the treatment location.

[0174] In one case, the filter is engaged with the retrieval device independent of the guidewire.

[0175] In another case, after crossing a treatment location with the guidewire the embolic protection device is introduced over the guidewire.

[0176] Preferably the deployed filter is retained independent of the guidewire against substantial longitudinal movement.

[0177] In one case, on deployment, the filter applies a radial force to the vasculature to substantially prevent movement of the filter relative to the vasculature in the deployed configuration.

[0178] In one case, the filter in the deployed configuration is anchored to the vasculature.

[0179] In one case, the method comprises the step of releasing the filter from the vasculature before retrieving the filter.

[0180] In another case, the filter is simultaneously released and retrieved by moving a retrieval catheter distally relative to the filter.

[0181] In another case, the filter is released prior to retrieving the filter.

[0182] According to one aspect, the method comprises the step of axially elongating the filter to release the filter.

[0183] According to a further aspect the invention provides a method of retrieving a medical device from a vasculature, the method comprising the steps of:

[0184] advancing a retrieval catheter through a vasculature until a distal end of the retrieval catheter is proximally of the deployed medical device;

[0185] axially elongating an element of the medical device to collapse the medical device; and

[0186] moving the retrieval catheter distally relative to the collapsed medical device to retrieve the medical device into the retrieval catheter.

[0187] In one case, the method comprises the steps of:

[0188] engaging a first coupling member with the element of the deployed medical device;

[0189] engaging a second coupling member with the element of the deployed medical device; and

[0190] moving the coupling members relative to one another to axially elongate the element of the medical device.

[0191] According to another aspect of the invention, there is provided an embolic protection filter for deployment in a vasculature, the filter having an inlet end and an outlet end, the inlet end having one or more inlet openings sized to allow blood and embolic material enter the filter, and the outlet end of the filter having a plurality of outlet openings sized to allow through passage of blood but to retain undesired embolic material within the filter;

[0192] the filter being movable between a collapsed configuration for movement through a vasculature, and an outwardly extended configuration for deployment in a vasculature;

[0193] the filter at least in the collapsed configuration having a guidewire lumen defined at least partially therethrough for passing the filter over a guidewire;

[0194] wherein the tubular member is shortenable upon movement of the filter from the collapsed configuration to the extended configuration.

[0195] In one embodiment, the tubular member comprises at least two telescopic tubes.

[0196] According to another aspect of the invention, there is provided an embolic protection filter for deployment in a vasculature, the filter having an inlet end and an outlet end, the inlet end having one or more inlet openings sized to allow blood and embolic material enter the filter, and the outlet end of the filter having a plurality of outlet openings sized to allow through passage of blood but to retain undesired embolic material within the filter;

- [0197] the filter being movable between a collapsed configuration for movement through a vasculature, and an outwardly extended configuration for deployment in a vasculature;
- [0198] the filter at least in the collapsed configuration having a guidewire lumen defined at least partially therethrough for passing the filter over a guidewire; wherein the filter comprises a support structure, in the collapsed configuration the support structure forming a tubular member to define the guidewire lumen.
- [0199] According to another aspect the invention provides a method for the capture and removal of embolic material from a vasculature during an interventional procedure comprising the steps of:
- [0200] advancing a guidewire through a vasculature;
- [0201] crossing a desired treatment location with the guidewire;
- [0202] introducing over the guidewire a collapsible embolic protection filter having a collapsed configuration for delivery and withdrawal of the filter, and a deployed configuration;
- [0203] deploying the filter distal to the treatment location;
- [0204] carrying out an interventional procedure at the treatment location, embolic material generated during the treatment procedure being captured by the deployed filter;
- [0205] advancing a retrieval catheter;
- [0206] fixing an abutment to the guidewire;
- [0207] engaging the guidewire abutment with the filter to prevent movement of the filter distally of the guidewire abutment;
- [0208] collapsing the filter and retrieving the filter into the retrieval catheter and with it the captured embolic material; and
- [0209] withdrawing the retrieval catheter and the collapsed filter from the vasculature.
- [0210] In one case, the abutment is fixed to the guidewire during deployment of the filter.
- [0211] In another case, the abutment is fixed to the guidewire before advancing the guidewire through the vasculature.
- [0212] According to another aspect of the invention there is provided a retrieval catheter for retrieving a medical device deployed in a vasculature, the catheter comprising:
- [0213] a first coupling member having means for coupling to a medical device deployed in a vasculature; and
- [0214] a second coupling member having means for coupling to the deployed medical device;
- [0215] the coupling members being relatively movable to axially elongate the medical device and collapse the medical device.
- [0216] In one embodiment, the catheter comprises an outer catheter body movable distally relative to the coupling members to retrieve a collapsed medical device into the catheter body.
- [0217] According to another aspect of the invention, there is provided an embolic protection filter for deployment in a vasculature, the filter having an inlet end and an outlet end, the inlet end having one or more inlet openings sized to allow blood and embolic material enter the filter, and the outlet end of the filter having a plurality of outlet openings sized to allow through passage of blood but to retain undesired embolic material within the filter; and
- [0218] the filter comprising an inflatable member to exert an outward radial force on a vasculature wall sufficient to retain the filter in position against substantial longitudinal movement.
- [0219] According to a further aspect of the invention there is provided an embolic protection filter system comprising:
- [0220] a collapsible embolic protection filter having a collapsed configuration for delivery of the filter, and a deployed configuration; and
- [0221] a snare for engaging the filter.
- [0222] In one embodiment, the filter has a snare engaging feature for engagement by the snare.
- [0223] In one embodiment, the filter comprises a support frame and the snare engaging feature is provided by or on the support frame.
- [0224] Preferably the snare is radiopaque at least in a region of engagement with a filter.
- [0225] In one embodiment, the snare engaging feature is radiopaque.
- [0226] In another embodiment, the snare comprises a snaring hoop.
- [0227] According to a further aspect the invention provides a method for the capture and removal of embolic material from a vasculature during an interventional procedure comprising the steps of:
- [0228] providing a collapsible embolic protection filter having a collapsed configuration for delivery of the filter, and a deployed configuration;
- [0229] advancing a guidewire through a vasculature;
- [0230] crossing a desired treatment location with the guidewire;
- [0231] deploying the filter distal to the treatment location;
- [0232] carrying out an interventional procedure at the treatment location, embolic material generated during the treatment procedure being captured by the deployed filter;
- [0233] advancing a snare;
- [0234] engaging the snare with the filter; and
- [0235] withdrawing the snare and the filter.
- [0236] In one case, the filter has a snare engaging feature and the snare is engaged with the snare engaging feature.

[0237] In another case, the snare engaging feature is provided on or by a support frame of the filter.

[0238] In one case, the method comprises the steps of leading the snare into engagement with the snare engaging feature of the filter and monitoring the engagement of the filter with the snare.

[0239] In one case, the snare and/or snare engaging features are radiopaque for external monitoring of the engagement.

[0240] In one case, the snare is engaged with the filter independent of the guidewire.

[0241] In another case, after crossing a treatment location with the guidewire the embolic protection device is introduced over the guidewire.

[0242] According to the invention, there is provided a method for the capture and removal of embolic material from a vasculature during an interventional procedure comprising the steps of:

[0243] advancing a guidewire through a vasculature;

[0244] crossing a desired treatment location with the guidewire;

[0245] introducing over the guidewire a collapsible embolic protection filter having a collapsed configuration for delivery and withdrawal of the filter, and a deployed configuration;

[0246] deploying the filter distal to the treatment location;

[0247] the filter in the deployed configuration being in apposition with the vasculature so that the filter is retained in position against substantial longitudinal movement, on deployment in the vasculature;

[0248] carrying out an interventional procedure at the treatment location, embolic material generated during the treatment procedure being captured by the deployed filter;

[0249] advancing a retrieval catheter;

[0250] collapsing the filter and retrieving the filter at least partially into the retrieval catheter and with it the captured embolic material; and

[0251] withdrawing the retrieval catheter and the collapsed filter from the vasculature.

[0252] In one embodiment of the invention the method comprises the step of releasing the apposition of the filter with the vasculature before collapsing the filter.

[0253] The filter may be simultaneously collapsed and retrieved into the retrieval catheter by moving the retrieval catheter distally relative to the filter.

[0254] Alternatively the filter may be collapsed prior to retrieving the filter into the retrieval catheter. Preferably the method comprises the step of axially elongating the filter to collapse the filter.

[0255] Desirably the method comprises the step of engaging a part of the retrieval catheter with the filter to aid collapsing of the filter.

[0256] In one case the method comprises the steps of:

[0257] withdrawing the guidewire from the filter and the desired treatment location; and

[0258] crossing the desired treatment location with another guidewire.

[0259] The interventional device may be introduced over the other guidewire for carrying out the interventional procedure.

[0260] In one case the interventional procedure comprises a stenting of the treatment location. In another case the interventional procedure comprises a balloon angioplasty procedure at the treatment location.

[0261] In another aspect the invention provides a method for the capture and removal of embolic material from a vasculature during an interventional procedure comprising the steps of:

[0262] advancing a guidewire through a vasculature;

[0263] crossing a desired treatment location with the guidewire;

[0264] introducing over the guidewire a collapsible embolic protection filter having a collapsed configuration for delivery and withdrawal at the filter, and a deployed configuration;

[0265] deploying the filter distal to the treatment location;

[0266] carrying out an interventional procedure at the treatment location, embolic material generated during the treatment procedure being captured by the deployed filter;

[0267] advancing a retrieval catheter;

[0268] fixing an abutment to the guidewire;

[0269] engaging the guidewire abutment with the filter to prevent movement of the filter distally of the guidewire abutment;

[0270] collapsing the filter and retrieving the filter into the retrieval catheter and with it the captured embolic material; and

[0271] withdrawing the retrieval catheter and the collapsed filter from the vasculature.

[0272] The abutment may be fixed to the guidewire during deployment of the filter. Alternatively the abutment may be fixed to the guidewire before advancing the guidewire through the vasculature.

[0273] In a further aspect of the invention, there is provided a retrieval catheter for retrieving a medical device deployed in a vasculature, the catheter comprising:

[0274] an outer catheter body; and

[0275] an inner coupling member having means for coupling to a medical device deployed in a vasculature;

[0276] the catheter body being movable distally relative to the coupling member to retrieve a coupled medical device into the catheter body.

[0277] In one embodiment of the invention the coupling means comprises a male or female member on the coupling

member for engagement with a corresponding female or male member on the medical device.

[0278] In a preferred case the male member is movable between a low-profile configuration and an outwardly protruding configuration. Ideally the male member is biased towards the outwardly protruding configuration. Most preferably the male member is of a resilient material.

[0279] In one case the coupling means is substantially arrow-head shaped.

[0280] In another case the male member is in the form of a hook for hooking around a female member on the medical device. Alternatively the male member may be in the form of a hook for hooking around a tether arm on the medical device. Ideally the tether arm is at a proximal end of the medical device. The tether arm may be located within the medical device.

[0281] In another embodiment of the invention the coupling means comprises at least one female member on the coupling member for engagement with at least one male member on the medical device. The female member may be in the form of a loop for looping around a protruding male member on the medical device.

[0282] In a preferred embodiment the coupling means comprises a pair of jaws on the coupling member, the jaws being movable between an outwardly protruding configuration and a low-profile configuration to grasp the medical device. The retrieval catheter may comprise an actuator to move the jaws to the outwardly protruding configuration. Ideally the actuator is movable longitudinally relative to the jaws to move the jaws in a camming arrangement to the outwardly protruding configuration. Most preferably the jaws are biased towards the low-profile configuration.

[0283] In another embodiment the catheter body is engageable with the jaws to move the jaws to the low-profile configuration. The jaws may be biased towards the outwardly protruding configuration.

[0284] In another embodiment of the invention the coupling means comprises an inflatable member on the coupling member for engagement with the medical device. Preferably the inflatable member is movable inwardly upon inflation to engage the medical device. The coupling means may comprise an engagement surface on the coupling member for engagement with an inflatable member on the medical device.

[0285] In a further embodiment the coupling member is at least partially of a magnetic material for magnetic coupling to an oppositely charged magnetic portion of the medical device.

[0286] The retrieval catheter may comprise means to axially elongate a deployed medical device to collapse the medical device to a low-profile configuration for retrieval into the catheter body. Preferably the elongation means comprises a second coupling member movable relative to the first coupling member to collapse the medical device. Ideally the second coupling member comprises a pusher member movable distally relative to first coupling member to engage a deployed medical device distally of the first coupling means and thereby collapse the medical device.

[0287] In one case the catheter body has a guidewire lumen extending partially therethrough for passing the cath-

eter body over a guidewire in a rapid exchange manner. The guidewire lumen may be offset radially from the coupling member.

[0288] The retrieval catheter of the invention may be for retrieving an embolic protection filter deployed in a vasculature.

[0289] According to another aspect of the invention, there is provided a retrieval catheter for retrieving a medical device deployed in a vasculature, the catheter comprising:

[0290] a first coupling member having means for coupling to a medical device deployed in a vasculature; and

[0291] a second coupling member having means for coupling to the deployed medical device;

[0292] the coupling members being relatively movable to axially elongate the medical device and collapse the medical device.

[0293] In one embodiment the catheter comprises an outer catheter body movable distally relative to the coupling members to retrieve a collapsed medical device into the catheter body.

[0294] In another aspect, the invention provides a method of retrieving a medical device from a vasculature, the method comprising the steps of:

[0295] advancing a retrieval catheter through a vasculature until a distal end of the retrieval catheter is proximally of the deployed medical device;

[0296] axially elongating an element of the medical device to collapse the medical device; and

[0297] moving the retrieval catheter distally relative to the collapsed medical device to retrieve the medical device into the retrieval catheter.

[0298] In one embodiment the method comprises the steps of:

[0299] engaging a first coupling member with the element of the deployed medical device;

[0300] engaging a second coupling member with the element of the deployed medical device; and

[0301] moving the coupling members relative to one another to axially elongate the element of the medical device.

[0302] The invention also provides in another aspect an embolic protection filter for deployment in a vasculature, the filter having an inlet end and an outlet end, the inlet end having one or more inlet openings sized to allow blood and embolic material enter the filter, and the outlet end of the filter having a plurality of outlet openings sized to allow through passage of blood but to retain undesired embolic material within the filter;

[0303] the filter being movable between a collapsed configuration for movement through a vasculature, and an outwardly extended configuration for deployment in a vasculature in apposition with a vasculature wall;

[0304] in the outwardly extended configuration the filter exerting an outward radial force on a vasculature wall sufficient to retain the filter in position against substantial longitudinal movement.

[0305] In one embodiment of the invention the filter comprises a filter body and a filter support frame to support the filter body in the outwardly extended configuration in apposition with a vasculature wall, the filter support frame providing the outward radial force.

[0306] The filter may comprise a low-friction outer layer. Preferably the outer layer is of a hydrophilic material.

[0307] In one case the filter comprises an inflatable member to enhance the outward radial force.

[0308] Ideally the filter defines a guidewire lumen for passing the filter over a guidewire.

[0309] According to another aspect of the invention, there is provided an embolic protection filter for deployment in a vasculature, the filter having an inlet end and an outlet end, the inlet end having one or more inlet openings sized to allow blood and embolic material enter the filter, and the outlet end of the filter having a plurality of outlet openings sized to allow through passage of blood but to retain undesired embolic material within the filter; and

[0310] the filter comprising a central tether extending proximally of the filter.

[0311] Ideally the tether is a generally central tether.

[0312] The tether may comprise a wire, preferably the wire is configured to facilitate passage of a medical device over the wire.

[0313] The invention also provides in a further aspect, an embolic protection filter for deployment in a vasculature, the filter having an inlet end and an outlet end, the inlet end having one or more inlet openings sized to allow blood and embolic material enter the filter, and the outlet end of the filter having a plurality of outlet openings sized to allow through passage of blood but to retain undesired embolic material within the filter; and

[0314] the filter comprising an inflatable member to exert an outward radial force on a vasculature wall sufficient to retain the filter in position against substantial longitudinal movement.

[0315] In another aspect, the invention provides a method for the capture and removal of embolic material from a vasculature during an interventional procedure comprising the steps of:

[0316] advancing a first guidewire through a vasculature;

[0317] crossing a desired treatment location with the first guidewire,

[0318] introducing over the first guidewire a collapsible embolic protection filter having a collapsed configuration for delivery and withdrawal of the filter, and a deployed configuration;

[0319] deploying the filter distal to the treatment location;

[0320] withdrawing the first guidewire from the filter and the desired treatment location;

[0321] crossing the desired treatment location with a second guidewire;

[0322] introducing over the second guidewire an interventional device;

[0323] carrying out an interventional procedure at the treatment location, embolic material generated during the treatment procedure being captured by the deployed filter;

[0324] advancing a retrieval catheter;

[0325] collapsing the filter and retrieving the filter into the retrieval catheter and with it the captured embolic material; and

[0326] withdrawing the retrieval catheter and the collapsed filter from the vasculature.

[0327] In one embodiment of the invention the method comprises the step of leading the second guidewire through the filter prior to carrying out the interventional procedure. The method may comprise the step of guiding the second guidewire through the filter. Ideally the second guidewire remains proximal of the deployed filter.

[0328] In another embodiment the method comprises the steps of:

[0329] withdrawing the second guidewire from the filter and the desired treatment location;

[0330] advancing a third guidewire to the filter; and

[0331] advancing the retrieval catheter over the third guidewire.

[0332] In one case collapsing the filter into the retrieval catheter comprises the step of releasing the filter from apposition with the vasculature wall.

[0333] The diameters of the guidewires may differ. The material properties of the guidewires may differ.

[0334] The invention provides in a further aspect an embolic protection filter assembly for deployment in a vasculature, the assembly comprising:

[0335] a filter having an inlet end and an outlet end, the inlet end having one or more inlet openings sized to allow blood and embolic material enter the filter, and the outlet end of the filter having a plurality of outlet openings sized to allow through passage of blood but to retain undesired embolic material within the filter; and

[0336] a receiver to guide a docking device into association with the filter.

[0337] In one embodiment the filter has a guidewire lumen for passing the filter over a guidewire, and the receiver is configured to guide a guidewire into the guidewire lumen. The guidewire lumen may extend only partially through the filter.

[0338] Preferably the receiver is configured to guide a coupling member towards the filter for coupling to the filter.

[0339] In one case the receiver comprises a funnel. Preferably the funnel is movable between a collapsed configuration for movement through a vasculature, and an outwardly extended configuration for guiding a docking device. Ideally the funnel is biased towards the outwardly extended configuration.

[0340] In one embodiment the funnel comprises a funnel body and a funnel support to support the funnel body in the outwardly extended configuration. Preferably the funnel body comprises a membrane. Ideally the funnel support comprises a plurality of pivotable fingers.

[0341] In another embodiment the receiver comprises an approach channel. Preferably the channel is provided by a lumen in a catheter.

[0342] The receiver may be mounted to the filter. Preferably the receiver is detachably mounted to the filter.

[0343] Alternatively the receiver may be separate from the filter.

[0344] In a preferred embodiment the receiver has means to space the receiver from the wall of a vasculature. Ideally the spacing means comprises an inflatable member to engage the wall of a vasculature.

[0345] In one embodiment the receiver is at least partially provided by a wall of the filter. Preferably the receiver is at least partially provided by a wall of the filter at the inlet end of the filter. Alternatively the receiver may be at least partially provided by a wall of the filter at the outlet end of the filter.

[0346] In one case the receiver extends proximally of the inlet end of the filter. In another case the receiver is located distally of the inlet end of the filter.

[0347] In a further embodiment the receiver is radially offset from the longitudinal axis of the filter.

[0348] According to a further aspect of the invention, there is provided an embolic protection system comprising:

[0349] an embolic protection filter assembly of the invention; and

[0350] a docking device which may be guided by the receiver into association with the filter.

[0351] In one embodiment the docking device comprises a guidewire.

[0352] In another case the docking device comprises a coupling member.

[0353] In another aspect, the invention provides an embolic protection filter having an inlet end and an outlet end, the inlet end having one or more inlet openings sized to allow blood and embolic material enter the filter, and the outlet end of the filter having a plurality of outlet openings sized to allow through passage of blood but to retain undesired embolic material within the filter;

[0354] the filter having a guidewire aperture for passing the filter over a guidewire; and

[0355] the filter comprising a seal to seal the guidewire aperture.

[0356] The seal may be self-closing.

[0357] Ideally the seal is located at a proximal end of the filter, and/or at a distal end of the filter.

[0358] The filter may have a tubular member extending from the guidewire aperture to define a guidewire lumen through the tubular member. In one case the tubular member

extends through at least part of the filter. Preferably the tubular member is radially offset from the longitudinal axis of the filter.

[0359] In one embodiment the seal is an annular member around the guidewire aperture, the annular member being closable down to seat the guidewire aperture. In one case the annular member is a tube. In another case the annular member comprises a soft membrane. The annular member may comprise two or more circumferentially overlapping flaps.

[0360] The invention provides in another aspect an embolic protection filter for deployment in a vasculature, the filter having an inlet end and an outlet end, the inlet end having one or more inlet openings sized to allow blood and embolic material enter the filter, and the outlet end of the filter having a plurality of outlet openings sized to allow through passage of blood but to retain undesired embolic material within the filter; the filter being movable between a collapsed configuration for movement through a vasculature, and an outwardly extended configuration for deployment in a vasculature;

[0361] the filter at least in the collapsed configuration having a guidewire lumen defined at least partially there-through for passing the filter over a guidewire.

[0362] The guidewire lumen may be defined by a tubular member extending at least partially through the filter.

[0363] In one case the tubular member is mounted to the filter. In another case the tubular member is spaced proximally of a distal end of the filter.

[0364] Preferably the tubular member is shortenable upon movement of the filter from the collapsed configuration to the extended configuration. Ideally the tubular member comprises at least two telescopable tubes.

[0365] In one embodiment the tubular member is provided by a catheter.

[0366] The catheter may be a retrieval catheter, or a delivery catheter.

[0367] In another embodiment of the invention the filter comprises a support structure, in the collapsed configuration the support structure forming a tubular member to define the guidewire lumen.

BRIEF DESCRIPTION OF DRAWINGS

[0368] The invention will be more clearly understood from the following description of some embodiments thereof, given by way of example only, with reference to the accompanying drawings, in which:

[0369] FIG. 1 is a perspective of an embolic protection filter according to the invention;

[0370] FIGS. 2 to 16 are partially cross-sectional, side views illustrating the use of an embolic protection filter;

[0371] FIG. 17 is a perspective view of another filter of the invention;

[0372] FIG. 18 is a side view of a further filter of the invention;

[0373] FIG. 19 is an end view of the filter of FIG. 18;

- [0374] FIG. 20 is a side view of another filter of the invention;
- [0375] FIGS. 21 and 22 are side views of another filter, in use;
- [0376] FIGS. 23 to 26 are diagrams illustrating a filter of the invention, in use;
- [0377] FIGS. 27 to 31 are perspective views of various alternative constructions of filters;
- [0378] FIGS. 32 to 39 are various views of a delivery catheter which may be used in the invention;
- [0379] FIGS. 40 to 54 are side, partially cross sectional views illustrating various steps in the method of the invention;
- [0380] FIGS. 55 to 57 are various views of another delivery catheter which may be used in the invention;
- [0381] FIGS. 58 to 61 are views illustrating the use of a temporary lumen-defining member for filter delivery;
- [0382] FIGS. 62 to 68 are views illustrating the use of a part of the delivery system to provide a temporary lumen-defining member;
- [0383] FIGS. 69 and 70 are perspective views of such a lumen-defining member extending to a side of a filter;
- [0384] FIGS. 71 and 72 are perspective views of such a lumen-defining member extending through a filter;
- [0385] FIG. 73 is a schematic view of another embolic protection filter according to the invention in a deployed configuration;
- [0386] FIG. 74 is a schematic view of the filter of FIG. 73 collapsed in a delivery catheter;
- [0387] FIG. 75 is a perspective view of another embolic protection filter according to the invention;
- [0388] FIG. 76 is a cross-sectional, side view of a delivery catheter according to the invention in a delivery configuration;
- [0389] FIG. 77 is a cross-sectional, side view of the filter of FIG. 75 collapsed in the delivery catheter of FIG. 87;
- [0390] FIG. 78 is a cross-sectional, side view of the delivery catheter of FIG. 76 in a deployment configuration;
- [0391] FIGS. 79 and 80 are views of a filter with a guidewire passageway at the side thereof;
- [0392] FIG. 81 is an enlarged view of a detail of FIG. 80;
- [0393] FIGS. 82 to 84 are perspective views illustrating different guidewire paths;
- [0394] FIG. 85 is a perspective view of another embolic protection filter according to the invention;
- [0395] FIG. 86 is an enlarged, perspective view of a receiver of the embolic protection filter of FIG. 85;
- [0396] FIGS. 87 to 89 are partially cross-sectional, side views illustrating guiding of a guidewire through the embolic protection filter of FIG. 85;
- [0397] FIG. 90 is a partially cross-sectional, side view of the embolic protection filter of FIG. 85 deployed in a vasculature;
- [0398] FIGS. 91 and 92 are enlarged, perspective views of seals of the embolic protection filter of FIG. 90;
- [0399] FIGS. 93 to 110 are partially cross-sectional, side views of the embolic protection filter of FIG. 85 in use;
- [0400] FIG. 111 is a side view of another retrieval catheter according to the invention passing over a guidewire;
- [0401] FIG. 112 is a view along line B-B in FIG. 111;
- [0402] FIGS. 113 and 114 are partially cross-sectional, side views illustrating retrieval of the filter of FIG. 1 using the retrieval catheter of FIG. 51(a);
- [0403] FIG. 115 is a perspective view of another embolic protection filter according to the invention;
- [0404] FIGS. 116 and 117 are perspective and cross-sectional, side views respectively of another embolic protection filter according to the invention;
- [0405] FIG. 118 is a perspective view of a further embolic protection filter according to the invention guiding a guidewire through the embolic protection filter;
- [0406] FIGS. 119 and 120 are partially cross-sectional, side views of the embolic protection filter of FIG. 118 guiding a guidewire through the embolic protection filter;
- [0407] FIG. 121 is an end view of the embolic protection filter of FIG. 118;
- [0408] FIG. 122 is a side view of a distal end of a filter;
- [0409] FIGS. 123 to 126 are end views in the direction of the arrow X of FIG. 122 of various outlet seals;
- [0410] FIG. 127 is a perspective view of the filter of FIGS. 122 to 126, in use;
- [0411] FIGS. 128 to 132 are various views of a filter with an alternative outlet seal;
- [0412] FIG. 133 is a perspective view of an alternative outlet seal;
- [0413] FIGS. 134 and 135 are cross-sectional views of the seal of FIG. 133, in use;
- [0414] FIGS. 136 and 137 are perspective views of further outlet seals;
- [0415] FIG. 138 is a perspective view of a further outlet seal;
- [0416] FIGS. 139 and 140 are cross-sectional views on the line A-A of FIG. 138 in different configurations of use;
- [0417] FIGS. 141 to 143 are views of a further outlet seal arrangement;
- [0418] FIGS. 144 to 149 are partially cross-sectional side views illustrating retrieval of an embolic protection device;
- [0419] FIGS. 150 to 163 are partially cross-sectional, side views of an embolic protection filter and a retrieval catheter in use;
- [0420] FIGS. 164 to 165 are partially cross-sectional, side views illustrating retrieval of another embolic protection filter according to the invention;
- [0421] FIGS. 166 and 167 are schematic side views illustrating retrieval of an embolic protection filter using other retrieval catheters according to the invention;

[0422] FIG. 168 is a perspective view of another embolic protection filter according to the invention;

[0423] FIG. 169 is a perspective view illustrating retrieval of the filter of FIG. 168;

[0424] FIG. 170 is a perspective view of another embolic protection filter according to the invention;

[0425] FIG. 171 is a perspective view illustrating retrieval of the filter of FIG. 170;

[0426] FIGS. 172 and 173 are perspective views of further embolic protection filters according to the invention;

[0427] FIGS. 174 to 178 are schematic views illustrating retrieval of the embolic protection filter of FIG. 168;

[0428] FIGS. 179 and 180 are perspective views of further embolic protection filters according to the invention;

[0429] FIGS. 181 and 182 are perspective views illustrating retrieval of another embolic protection filter according to the invention;

[0430] FIG. 183 is a perspective view of another embolic protection filter deployed in a vasculature;

[0431] FIG. 184 is a side view of part of another retrieval catheter according to the invention;

[0432] FIG. 185 is a cross-sectional, side view of the retrieval catheter of FIG. 184;

[0433] FIGS. 186 to 188 are schematic side views illustrating retrieval of an embolic protection filter using the retrieval catheter of FIG. 184;

[0434] FIG. 189 is a side view along line A-A in FIG. 188;

[0435] FIGS. 190 to 192 are cross-sectional side views illustrating retrieval of an embolic protection filter using another retrieval catheter of the invention;

[0436] FIG. 193 is a cross-sectional, side view of part of another retrieval catheter according to the invention;

[0437] FIG. 194 is a partially cross-sectional, side view illustrating collapse of an embolic protection filter using the retrieval catheter of FIG. 193;

[0438] FIGS. 195 to 201 are various views illustrating the snaring of an embolic protection device of the invention;

[0439] FIGS. 201 to 206 are various views illustrating snaring of another filter;

[0440] FIGS. 207 to 212 are various views illustrating snaring of a further filter;

[0441] FIGS. 213 to 218 are views illustrating another retrieval system;

[0442] FIGS. 219 to 234 are views of the snaring of a filter of the invention;

[0443] FIGS. 225 and 226 are views of another filter of the invention;

[0444] FIGS. 227 to 230 illustrate retrieval of filters;

[0445] FIGS. 231 and 232 illustrate snaring of another filter;

[0446] FIGS. 233 to 237 are side, partially cross-sectional views of the snaring of any filter;

[0447] FIGS. 238 and 239 illustrate the snaring of another filter;

[0448] FIG. 240 is a partially cross-sectional, side view of an embolic protection filter according to the invention in an expanded configuration;

[0449] FIG. 241 is a partially cross-sectional, side view of the filter of FIG. 240 in a collapsed configuration;

[0450] FIGS. 242 and 243 are partially cross-sectional, side views illustrating retrieval of the filter of FIG. 240;

[0451] FIG. 244 is a partially cross-sectional, side view of the filter of FIG. 240 after being recrossed with a guidewire;

[0452] FIGS. 245 and 246 are partially cross-sectional, side views illustrating retrieval of the filter of FIG. 244.

[0453] FIGS. 247 to 251 are views similar to FIGS. 90, 91, and 94 to 96 respectively of another embolic protection filter according to the invention;

[0454] FIG. 252 is a schematic view illustrating fixing of an abutment to a guidewire;

[0455] [253 to 255 are not used]

[0456] FIG. 256 is a schematic view of the guidewire and the abutment;

[0457] FIG. 257 is a perspective view of another embolic protection filter according to the invention passing over a guidewire;

[0458] FIGS. 258 to 260 are partially cross-sectional side views illustrating guiding of a guidewire through an embolic protection filter;

[0459] FIG. 261 is a cross-sectional, end view of a catheter according to the invention;

[0460] FIG. 262 is a cross-sectional, end view of a catheter according to the invention;

[0461] FIG. 263 is a cross-sectional, side view of another retrieval catheter according to the invention; and

[0462] FIG. 264 is a partially cross-sectional, side view illustrating retrieval of an embolic protection filter using the retrieval catheter of FIG. 263.

Detailed Description

[0463] The invention provides an embolic protection system which has a number of features which allows the system to be used in placing a guide catheter proximal to lesion as per standard practice and advance any suitable guidewire across the lesion. A load filter is loaded into the delivery catheter in such a way as to provide a lumen through the loaded device through which the guidewire will pass. The loaded device is advanced over the guidewire and across the lesion. The filter is deployed from the delivery catheter and the delivery catheter is removed. The filter remains stable in the vessel without any user control. Standard interventional procedures (angioplasty, stent etc . . .) can be performed. The guidewire may be replaced by simply removing the initial wire and advancing a replacement wire through the guide catheter, across the lesion and through the filter. The filter may be retrieved by advancing a retrieval catheter over the guidewire and up to the filter. An inner member of the retrieval catheter may be engaged with the filter. Then outer

retrieval sheath is advanced to collapse the filter and retrieve. The guidewire may be left in place if desired.

[0464] Referring to the drawings and initially to FIG. 1 there is illustrated an embolic protection filter 1 according to the invention, the filter 1 being suitable for deployment in a vasculature to filter undesired embolic material from the blood stream flowing through the vasculature.

[0465] The filter 1 comprises a collapsible filter body 2 which in this case is supported by a collapsible filter support frame 3. In this case the filter support is mounted on an inner tube 8.

[0466] The filter body 2 has an inlet end 4 and an outlet end 5. The inlet end 4 has one or more, and in this a single, large inlet opening 6 which are sized to allow blood and embolic material enter the filter body 2. The outlet end 5 has a plurality of small outlet openings 7 which are sized to allow through passage of blood but to retain undesired embolic material within the filter body 2. In this way, the filter 1 captures and safely retains any undesired embolic material in the blood stream within the filter body 2 while facilitating continued flow of blood through the vascular system. Emboli are thus prevented from flowing further downstream through the vascular system, which could otherwise have potentially catastrophic results.

[0467] The relatively large inlet opening 6 provide for the possibility of aspirating embolic material from within the filter body 2. This may be particularly advantageous if it is desired to leave the filter 1 in place in a vasculature for a long period of time, for example overnight, to assist in vascular recovery.

[0468] The filter body 2 may have a low-friction outer layer, for example a hydrophilic coating, to minimise frictional resistance during deployment and retrieval of the filter 1, and the filter body 2 may be of an oriented polymeric material, as described in International patent application No. PCT/IE01/00087, the relevant contents of which are incorporated herein by reference.

[0469] The inner tube 8 has a guidewire lumen 12 there-through for passing the filter 1 over a guidewire 10. A guidewire 10 can pass through the filter, however, in the deployed configuration the filter is independent of the guidewire. Thus, the guidewire can be moved independently of the filter without any associated movement of the filter. The arrangement allows relatively large radial forces to be exerted on the vascular wall without the risk of abrasion caused by movement of the deployed filter. In this way damage to the endothelium can be avoided.

[0470] The filter 1 is movable between a low-profile, collapsed configuration for movement through the vasculature, and an outwardly extended configuration for deployment in the vasculature in apposition with the vasculature wall.

[0471] In the outwardly extended configuration, the filter body 2 is supported in an expanded position by the filter support 3 so as to maximise the internal volume of the filter body 2 to capture and safely retain as much embolic material as possible.

[0472] The filter support 3 supports the filter body 2 in the outwardly extended configuration in apposition with the

vasculature wall to prevent blood flow bypassing the filter 1 between the filter body 2 and the vasculature wall.

[0473] The support frame in this case defines a proximal support hoop 15 which is connected to the tubular member 8 by a support arm 16. The support 3 in this case also comprises a number of axially extending portions 17 which assist in providing body support to the filter in a vessel and assist in preventing rotation of the filter when deployed in the deployed configuration. The support may be of wire and may also comprise one or more stabilising hoops(s) 18.

[0474] In this case the tubular member 8 terminates proximally of the distal end 5 of the filter. This has a number of advantages. It facilitates recrossing of the filter 1 with a guidewire and the distal free end of the tubular member 8 may be readily snared for snaring and/or retrieval of the filter when it is desired to remove the filter from the vasculature.

[0475] In the outwardly extended configuration, the filter support 3 exerts an outward radial force on the filter body 2 and the vasculature wall which results in a frictional force between the filter body 2 and the vasculature wall sufficient to retain the filter 1 in position against substantial longitudinal movement.

[0476] In the invention the filter will not rotate or collapse in the absence of guidewire support. Conventional filters are coupled (directly or indirectly) to a wire—this wire enhances the stability of the filter. This invention describes a filter which will remain fully open and opposed to the vessel wall in the absence of any support from a guidewire. This is achieved by using a support frame which does not allow rotation in the vessel lumen. In general, a frame which lies in only one plane cannot remain apposed to the vessel wall without support from the guidewire. The design of the system is such that the filter must do considerable work to move longitudinally.

[0477] In order to ensure that the filter is retained in position the filter apposition force generates a frictional force between the filter and the vessel. The frictional force generated by the filter is dependent on the contact area, the apposition force generated by the filter and the coefficient of static friction between the filter and the vessel. Locating the filter using frictional forces alone is a worst-case analysis as it does not include the effect of tapered vessels. These will increase the apposition force generated by the filter as it moves distally into a lumen of decreasing diameter.

[0478] The radial apposition force of the filter support 3 is sufficient to retain the deployed filter 1 in position in the vasculature against substantial longitudinal movement, even if the guidewire, over which the filter 1 is delivered, is moved. No step, abutment or other stop means is required on the guidewire to prevent the filter 1 from migrating downstream in the vasculature. In this manner, the invention enables an interventional procedure to be performed using a standard guidewire. This enhances clinician freedom by enabling a clinician to choose the most appropriate medical guidewire for a particular interventional procedure, and/or a particular patient anatomy.

[0479] In the case of a filter which has an integral tubular member the tubular member defines a lumen through which a guidewire can pass. In the invention such a guidewire passageway may be provided by a component of the delivery system such as a portion of a deployment pusher.

Alternatively, the tubular member may be a separate component which is removed after the guidewire has passed through the filter. Thus, the member defining a guidewire pathway through the filter may be a movable or removable component.

[0480] Referring to FIGS. 2 to 16 there are illustrated various steps in the use of an embolic protection device during an interventional procedure. Various steps in the method will be described and it will be appreciated that the various steps and the features of the various apparatus used in the method may be used independently of one another, for example in the methods and apparatus of other aspects of the invention.

[0481] The filter does not necessarily itself have a predetermined lumen for passage of a guidewire. At various stages a lumen is defined when such a lumen is required. On loading of a filter 20 into a delivery catheter 21 a guidewire lumen is defined (FIG. 2) which is used for delivery of the filter 20 over a pre-positioned guidewire 10 (FIG. 3). The lumen-defining member 22 may be removed (FIG. 3) and the filter is advanced to and deployed distal to a treatment location in the vasculature (FIGS. 4 and 5). Various procedures may be carried out such as balloon angioplasty and stenting (FIGS. 6 and 7). The filter may be retrieved into a retrieval catheter 25 (FIGS. 11 to 15) and the filter removed.

[0482] In this case the filter 20 comprises a filter body supported in the deployed configuration by a support frame 3 defining a large proximal opening 6 and having a snaring engaging element in the form of a hook 26. In use, the filter is loaded into a delivery catheter L6 by inserting a tubular element 22 through the filter. The delivery catheter may be threaded onto a pre-deployed bare guidewire 10, the tubular element 22 guiding the guidewire 10 through the filter 20 at the distal end of the delivery catheter 21. Once the guidewire 10 has entered the delivery catheter 21 proximal to the filter 20 the tubular element 22 may be removed. To facilitate this, the tubular element may be of C-shape in transverse cross section. The delivery catheter 21 is then advanced over the guidewire 10 to a location which is distal of a treatment site. The filter 20 is deployed by pushing it out from the distal end of the delivery catheter, for example by using a pusher. The filter is then in the deployed open configuration distal to a treatment location (FIG. 5). Various procedures may be carried out at the treatment location, and embolic material released during the treatment procedures being captured in the filter. The treatment procedures may include deployment of a stent 29 from a stent delivery catheter threaded over the guidewire 10. When it is desired to retrieve the filter a retrieval catheter 25 is delivered over the guidewire 10. The retrieval catheter 25 may be a snare catheter or a separate snare catheter may be delivered through the retrieval catheter. The snare may comprise a lasso 30 or the like which engages the snaring hook 26 of the filter support frame. The guidewire 10 may then be withdrawn or left in place.

[0483] In certain circumstances the guidewire 10 could be retracted, or even removed completely (FIG. 8), without disturbing the position of the deployed filter in the vasculature. Another guidewire 10A may be advanced through the filter (FIGS. 9 and 10). This may be particularly advantageous in the case of certain interventional procedures, for example in coronary applications as will be described in more detail below.

[0484] The support 3 may be configured to distribute the outward radial force over a relatively large area of the vasculature wall to minimise local stress distributions.

[0485] Many different designs of filter may be used such that on deployment, the filter applies a local radial force to the vasculature to substantially prevent movement of the filter relative to the vasculature in the deployed configuration. In the deployed configuration the filter is anchored to the vasculature. In some cases the filter comprises a filter body and a filter support frame to support the filter in the deployed configuration. The support frame and/or the filter body may comprise the anchor. The anchor may comprise a plurality of anchor elements which may be spaced-apart circumferentially around the filter when the filter is in the deployed configuration.

[0486] Referring to FIG. 17 the filter frame includes a proximal support hoop 31 with radially projecting vessel indentors or stabilisers 32 to prevent longitudinal movement of the filter in the vessel. The frame may include a snaring feature 33 which may have a radiopaque marker 34.

[0487] Referring to FIGS. 18 and 19 the vessel indentors or stabilisers 32 may also provide convenient attachment locations for attachment of tethers 35. The tethers 35 may be interconnected at the proximal end by a connector 36 which may be radiopaque for ease of location to snare the filter for retrieval.

[0488] Referring to FIG. 20 the filter may have an enlarged lip 37 at the proximal end for engagement in a vessel to anchor the filter in a desired position.

[0489] Referring to FIGS. 21 and 22 there is illustrated another filter which is apposed in a vessel. The filter has a retrieval mechanism somewhat like a closed drawstring arrangement with a mesh-like structure 38, when deployed, which may be engaged by the distal tip 39 of a centering catheter (or any suitable snare) for collapsing the filter and drawing it into a retrieval catheter 40.

[0490] Another filter frame is illustrated in FIGS. 23 to 26. The frame has a proximal hoop 41 and distally projecting arm 42. X denotes terminations of the bifilar type to facilitate wrap-down of the filter as illustrated in FIGS. 24 and 25. Thus, the parking space occupied by the filter is optimised. In the deployed configuration in a vessel as schematically illustrated in FIG. 26 the filter apposes the vessel wall and rotation and translation of the filter in relation to the vasculature is prevented.

[0491] In general, the filter applies sufficient radial force to remain stable in a vessel when in the deployed configuration. In addition, the filter remains correctly orientated even without a guidewire in place. Some filters of this type are illustrated in FIGS. 27 to 31. In FIG. 27 the filter 43 has body support. In FIG. 28 the filter 44 has stabilising arms 45. The filter of FIG. 29 is in the form of a hoop 46 with a number of inflection points 47. There may be four or more such inflection points as illustrated.

[0492] In FIG. 30 the filter has two axially spaced-apart support hoops 48 which are interconnected by connecting arms 49. The filter of FIG. 31 has two offset hoops 50. Any of these filters may be connected to a central tubular member by a rigid member(s) and/or by a tether(s). Many more arrangements with support in more than one place are envisaged.

[0493] The filter 51 of FIG. 32 has body support provided by a nitinol tube or wire.

[0494] To retrieve the filter 710, any suitable means, such as the hooked retrieval catheter (FIG. 250), or the looped retrieval catheter (FIG. 251) may be used, in a manner similar to that described previously with reference to FIGS. 242 and 243.

[0495] Referring to FIGS. 32 to 39 there is illustrated a delivery catheter 200 which may be used with a filter of the invention. This catheter is described in detail in our co-pending U.S. Ser. No. 10/180,980, the relevant contents of which are incorporated herein by reference. The delivery catheter 200 comprises a catheter body 202 which extends between a proximal end 203 and a distal end 204, a restraining sheath 210 at the distal end 204 of the catheter body 202, and an elongate actuator, which is provided in this case in the form of a stainless steel wire 209.

[0496] The catheter body 202 comprises a proximal hypotube portion 205 and a radially offset distal spring pusher 206. As illustrated in FIGS. 34 and 35, the pusher 106 is fixedly attached to the hypotube 205 in a side-by-side overlapping arrangement with the proximal end of the pusher 206 located proximally of the distal end of the hypotube 205.

[0497] The pusher 206 has a guidewire lumen 16 extending through the pusher 206 with an opening 217 at the proximal end of the lumen 216 for passage of a guidewire 222 through the lumen 216 and out through the proximal guidewire opening 217 (FIG. 35). The delivery catheter 200 is thus configured to be passed over the guidewire 22 in a rapid-exchange manner.

[0498] The pusher 206 tapers proximally inwardly at the opening 217 for a smooth crossing profile.

[0499] When assembled, the hypotube 205 and the pusher 206 are located substantially side-by-side. This side-by-side assembly of the hypotube 205 relative to the pusher 206 enables the guidewire 222 to exit through the proximal guidewire opening 217 smoothly and substantially parallel to the longitudinal axis of the catheter 200. In particular, the passage of the guidewire 222 through the proximal guidewire opening 217 does not increase the overall profile of the catheter 200.

[0500] A connector shaft 212 is fixed to the sheath 210 with the shaft 212 extending proximally over the pusher 206 towards the distal end of the hypotube 205. The proximal end of the sheath 210 overlaps the distal end of the shaft 212, and a marker band 213 is located at the distal end of the shaft 212 between the shaft 212 and the sheath 210.

[0501] The actuator wire 209 extends distally through an actuator lumen 232 in the hypotube 205, out of the actuator lumen 232 at the distal end of the hypotube 205, externally along the pusher 6 to the proximal end of the shaft 212. The wire 209 is attached to the exterior surface of the shaft 212, for example by bonding. By attaching the wire 209 to the exterior of the shaft 212, this arrangement provides for more space within the pusher lumen 216 for guidewire passage. In addition, attachment of the actuator wire 209 to the exterior of the shaft 212 is an easier step to achieve from a manufacturing viewpoint than attachment to the interior of the relatively long shaft 12.

[0502] The restraining sheath 210 and the connector shaft 212 are movable in a sliding manner relative to the catheter body 202. When the sheath 210 extends distally of a distal end of the spring pusher 206, the sheath 210 defines an internal reception space 211, as illustrated in FIGS. 36 to 38. A collapsed embolic protection filter 301 may be received within the reception space 211, where the filter 231 will be restrained by the sheath 210 in a low-profile configuration during delivery to a desired site in a vasculature. A suitable material for the sheath 210 is polyethyleneterephthalate (PET).

[0503] The distal end of the shaft 212 is flared outwardly (FIG. 38). During delivery of the filter 231, the distal end of the pusher 206 is spaced proximally of the distal end of the shaft 212, and the proximal end of an inner tubular member 236 of the filter is partially inserted into the flared shaft 212. This arrangement provides a bridge in stiffness between the relatively stiff shaft 212 and the relatively stiff inner tubular member 236 of the filter 231. Thus the possibility of buckling of the relatively flexible sheath 10 is minimised. The distal end of the pusher 206 is engagable with the inner tubular member 236 of the filter 231 upon retraction of the sheath 210 to deploy the filter 231 out of the reception space 211.

[0504] As illustrated in FIG. 39, at the proximal end 203 of the catheter 200 a distal handle 208 is provided for gripping the catheter body 202 and a proximal handle 214 is provided for gripping the actuator wire 209. The distal handle 208 is injection moulded over the hypotube 205 and the proximal handle 214 is crimped to the proximal end of the wire 209.

[0505] The handles 208, 214 are movable relative to one another in a telescoping manner with the proximal handle 214 sliding within the distal handle 208. Movement of the handles 208, 214 is limited by means of stop means. Abutment of an outward annular protrusion 233 on the proximal handle 214 against the proximal end of the distal handle 208 prevents further movement of the proximal handle 214 distally relative to the distal handle 208. Engagement of a shoulder 234 on the proximal handle 214 with an inward annular protrusion 235 on the distal handle 208 prevents further movement of the proximal handle 214 proximally relative to the distal handle 208. A releasable safety clip 237 is provided to maintain the handles 208, 214 fixed relative to one another.

[0506] When the catheter 200 is assembled the sheath 10 is directly connected to the proximal handle 214, and the pusher 206 is directly connected to the distal handle 208. Movement of the proximal handle 214 proximally relative to the distal handle 208 moves the wire 209, the connector shaft 212 and the sheath 210 proximally relative to the pusher 206 to facilitate deployment of the filter 231 from within the reception space 211.

[0507] The delivery catheter 200 may be used to deliver the embolic protection filter 231 through a vasculature and to deploy the embolic protection filter 231 downstream of a stenosed region in the vasculature to prevent potentially harmful emboli, which may be released into the blood stream during treatment of the stenosis, such as by a stenting procedure, from migrating further through the vascular system.

[0508] Referring to FIGS. 40 to 54 the use of the delivery catheter 200 will now be described in relation to a filter 301

of the invention which has tubular member 306 with a distal end that is spaced proximally from the distal end of the filter. Such an arrangement facilitates removal/replacement of a guidewire and can also be readily snared and retrieved as described herein.

[0509] In use, a loading device 310 is partially inserted into the reception space 211 of the sheath 210. A pushing device 311 is then threaded through the tubular member 306 of the filter 301 and extended into the reception space 211, as illustrated in FIG. 40.

[0510] By moving the pushing device 311 proximally, an engagement stop 312 on the pushing device 311 engages the distal end of the tubular member 306 and the filter 301 is moved towards the loading device 310 (FIG. 10). Continued proximal movement of the pushing device 311 pushes the filter 301 through the loading device 310, thereby collapsing the filter 301, and into the reception space 11 (FIG. 41).

[0511] The catheter 200 with the collapsed filter 301 received within the reception space 11 are then moved together proximally away from the loading device 310 (FIG. 42).

[0512] The method of collapsing the filter 301 and loading the filter 301 into the reception space 211 is similar to that described in International patent application number PCT/IE01/00052, the relevant contents of which are incorporated herein by reference.

[0513] Next the guidewire 222 is inserted into a vasculature 315 and advanced through the vasculature 315 until the guidewire 222 has crossed a site of interest in the vasculature 315 (FIG. 44). A typical site of interest is a stenosed or diseased region 316 of the vasculature 315. The delivery catheter 200 is then threaded over the guidewire 222 by inserting the proximal end of the guidewire 222 into the guidewire lumen 216 at the distal end of the pusher 206, through the lumen 216, and out of the lumen 216 through the proximal guidewire opening 217. The catheter 200 is advanced over the guidewire 222 in a rapid-exchange manner until the reception space 211 is located downstream of the stenosis 316 (FIG. 45).

[0514] To deploy the filter 301 at the desired site in the vasculature 315 downstream of the stenosis 316, the proximal handle 14 is moved proximally while holding the distal handle 208 fixed, thereby causing the pull wire 209 and the connector shaft 212 to be pulled proximally. Because the connector shaft 212 is attached to the sheath 210, the sheath 210 also moves proximally while the pusher 206 does not move. In this way, the collapsed filter 301 is uncovered by the sheath 10 while the distal end of the pusher 206 abuts the proximal end of the tubular member 306 of the filter 301. The delivery catheter 200 thus enables the self-expanding filter 301 to expand outwardly to a deployed configuration. The distal end of the pusher 6 acts as an abutment for a controlled, accurate deployment of the filter 301 at the desired site in the vasculature 315.

[0515] When the filter 230 has been fully deployed at the desired site in the vasculature 315, the delivery catheter 200 is withdrawn from the vasculature 315 over the guidewire 222 in a rapid-exchange manner to leave the deployed filter 301 in place in the vasculature 315 (FIG. 48).

[0516] Various procedures can be carried out using the guidewire such as an angioplasty using a balloon 320 (FIG.

49) or a stenting procedure with a stent 321 (FIG. 50). On completion of the procedures a retrieval device such as a retrieval catheter 325 or snare may be used to retrieve the filter (FIGS. 51 to 53). The guidewire 222 may be left in place or removed.

[0517] In FIGS. 55 to 57 there is illustrated another delivery catheter 600 according to the invention, which is similar to the delivery catheter 200 and similar elements are assigned the same reference numerals. In this case the distal end of the shaft 212 is not flared outwardly, and the proximal end of the inner tubular member 306 is not inserted into the shaft 212, during delivery of the embolic protection filter 610.

[0518] Instead a bridging sleeve 601 is provided mounted around the shaft 212 distally of the marker band 213, as illustrated in FIG. 57. The sleeve 601 extends distally of the distal end of the shaft 212, such that the proximal end of the inner tubular member 306 of the filter 610 may be partially inserted into the sleeve 601 during delivery of the filter 610 (FIG. 57). This arrangement provides a bridge in stiffness between the relatively stiff shaft 212 and the relatively stiff inner tubular member 306 of the filter 610. Thus the possibility of buckling of the relatively flexible sheath 210 is minimised.

[0519] It is noted that the filter 610 of FIGS. 57(a) to 57(c) is of a different configuration to the filter described previously. In particular the inner tubular member 306 of the filter 610 does not have any step formations or protrusions at the proximal end of the inner tubular member 306.

[0520] The delivery catheter of the invention is also suitable for over-the-wire exchange over a guidewire. The rapid exchange configuration is not essential.

[0521] Referring to FIGS. 58 to 61 there is illustrated one means of temporarily providing a tubular lumen in a filter to facilitate delivery of the filter to a desired location. In this case an introducer tool is in the form of a C-shaped tubular member 60 with a distal peel-back feature 61. The tool is inserted into the distal end of the filter 62 as illustrated in FIG. 58. The filter is loaded into a distal pod 63 of a delivery catheter 64 (FIG. 58) and the distal end of the delivery catheter 64 is threaded over the proximal end of a deployed guidewire 65. When the guidewire has passed through the filter the introducer may be pulled away and removed as illustrated in FIG. 61.

[0522] In another arrangement illustrated in FIGS. 62 to 65 the delivery catheter 70 may itself be provided with a member 71 defining a temporary tubular member for a guidewire. The tubular member may also function as a pusher. In one case once the guidewire has traversed the filter 62 the tubular member 71 may be positioned proximal of the filter during delivery and deployment (FIGS. 63 to 65). In another case (FIGS. 66 to 68) the tubular member 71 may extend through the filter up to the stage when the delivery catheter is being withdrawn.

[0523] The pusher 71 may pass through the centre (FIGS. 71 and 72) of the filter or may run beside the filter (FIGS. 69 and 70).

[0524] In FIGS. 73 and 74, there is illustrated another embolic protection filter 520 according to the invention. In the case of filter 520, the guidewire lumen 521 through the

filter **520** is defined by two telescoping tubes **522**, **523**. The proximal tube **522** is fixed to the filter **520** at the proximal end of the filter **520**, and the distal tube **523** is fixed to the filter **520** at the distal end of the filter **520**.

[0525] In the deployed configuration of FIG. 73, the distal tube **523** telescopes proximally over the proximal tube **522** so that the overall parking space of the filter **520** in a vasculature is minimised. In addition the distal tube **523** is spaced distally of the guidewire aperture **112** to facilitate crossing of the filter **520** with a guidewire without requiring the guidewire to be threaded through the tubes **522**, **523**.

[0526] In the collapsed configuration of FIG. 74, the distal tube **523** telescopes distally over the proximal tube **522** so that the guidewire lumen **521** is defined through the entire length of the filter **520** when collapsed, for example in a pod **524** of a delivery catheter **525**.

[0527] The invention also envisages the use of a delivery catheter **650**, as illustrated in FIGS. 75 to 89, which is particularly suitable for delivering an embolic protection filter **651**, as illustrated in FIG. 77, the filter **651** not having an inner tubular member to define a guidewire lumen through the filter **651**.

[0528] The delivery catheter **650** comprises an outer tubular member **652**, and an inner tubular member **653**, the inner tubular member **653** being movable distally relative to the outer tubular member **652** from a delivery configuration (FIG. 76) to a deployment configuration (FIG. 78).

[0529] In the delivery configuration, the catheter **650** defines a reception space **654** for receiving the filter **651** in a collapsed configuration, as illustrated in FIG. 77. When the inner tubular member **653** is moved distally relative to the outer tubular member **652**, the filter **651** is pushed distally out of the reception space **654** by means of an engagement between a shoulder **655** of the inner tubular member **653** and the collapsed filter **651**.

[0530] The invention provides features to enable a guidewire to be repositioned across the filter. It may be necessary to be able to replace the guidewire if the wire became accidentally withdrawn by the user during the procedure. It may then be necessary to replace the wire in order to access the lesion with other devices such as a balloon or stent catheter or even the filter retrieval catheter. Merely advancing a wire up to the filter is unlikely to provide sufficient support in all cases. Guidewire replacement may also be needed if the user desires to use a wire with different properties during the procedure. For example a very torqueable wire may be ideal for initially accessing and crossing the lesion, and may have adequate support to enable the filter to be delivered and deployed, but may not have sufficient support to enable a stiffer stent delivery system to reach the lesion. The invention facilitates removal of the first wire and replacement with a more supportive guidewire to facilitate use of the stent delivery system. This may be achieved without having to use an additional exchange catheter.

[0531] This invention describes a filter which comprises a guidewire recrossing feature, wherein this feature may comprise some or all of a guiding funnel, a pathway and a blood restrictor. A guiding funnel is used as this operation will be performed “blind”. In general, it would be difficult to replace a guidewire through a tubular lumen while the filter is in the

patient. In the invention the guidewire may be passed through the distal filter neck. The distal cone of the filter will act as a guiding channel. However the guidewire tip is very flexible—if it is to open a “valve” or blood restrictor it will need to have good push. In order to provide this push it is necessary to restrain the guidewire tip within a relatively narrow channel—this channel is provided by the filter neck. A restrictor may be provided to prevent any loss of embolic material while the first guidewire was absent—during which period the neck of the filter would be an open hole if no restrictor were present. This restrictor is intended simply to close and prevent blood flow in the absence of a guidewire. Once there is no blood flow through the filter neck embolic material will not collect there and will not restrict the passage of the second guidewire.

[0532] Various guideways may be provided for a guidewire to assist crossing of a filter. Referring to FIGS. 79 to 81 the pathway may be provided around the filter, for example in a side channel **80**. A radiopaque feature **81** may be provided on the filter to guide a user to the passageway. Alternatively the pathway may be through the filter to a single exit **82** (FIG. 82), a separate exit **83** (FIG. 83) or through the same exit **84** using a shortened tubular member **85** illustrated in FIG. 84 and described in more detail herein. In these cases the guidewire passage/hole may be sealed to prevent passage of embolic therethrough as will be described in more detail below.

[0533] Referring now to FIGS. 85 to 92, there is illustrated another embolic protection filter **50** according to the invention. The filter **150** comprises a receiver to guide a docking device into association with the filter **150**. In this case, the receiver is configured to guide a guidewire, such as the guidewire **130**, into the guidewire lumen **112**. The receiver is provided by a funnel **151** which diverges outwardly proximally, the funnel **151** being mounted to the filter **150** to extend proximally of the inlet end of the filter **150**.

[0534] In this specification, the term funnel will be understood to mean any orifice with a cross-sectional area that decreases with distance.

[0535] The funnel **151** may comprise a collapsible funnel body in the form of a membrane **152**, which in this case is supported by a collapsible funnel support, in the form of a plurality of support fingers **153**. The fingers **153** are pivotally mounted to the filter **50** and are biased to move the filter membrane **152** from a collapsed configuration for movement through the vasculature, to an outwardly extended configuration for guiding the guidewire **130**, as illustrated in FIG. 86. The funnel **151** may be of a radiopaque material.

[0536] The funnel **151** may be used to guide the guidewire **130** along a pathway that enables the guidewire **130** to cross the filter **150**. The funnel **151** allows the procedure of leading the small diameter guidewire **130** through the small diameter guidewire lumen of the filter **150** to be performed more easily by guiding the tip of the guidewire **130** towards the proximal end of the guidewire lumen **158**.

[0537] Use of the funnel **151** is particularly beneficial in the case where it is desired to lead the guidewire **130** through the guidewire lumen while the filter **150** is deployed in the vasculature, as illustrated in FIGS. 87 to 89. The funnel **151** enables a clinician to accurately and quickly thread the guidewire **130** through the guidewire lumen without risk of

puncturing the filter body or of disturbing the filter **50** from its deployed position in the vasculature in apposition with the wall of the vasculature.

[0538] The filter **150** further comprises at least one, and in this case two, seals **160, 161** to seal the guidewire lumen **158** to prevent embolic material from passing through the guidewire lumen **158**, when the filter **150** is in use in the vasculature.

[0539] The seals **160, 161** are self-closing. In this case one seal **160** located at the proximal end of the filter **150**, and the other seal **161** located at the distal end of the filter **150**.

[0540] The proximal seal **160** may be in the form of a tubular member of a soft membrane material. The guidewire lumen **158** extends through the tubular seal **160** and the seal **160** is closable down to seal the guidewire lumen **158**.

[0541] The distal seal **61** is in the form of a tubular member with two or more, and in this case seven, circumferentially overlapping flaps, as illustrated in FIG. **92**. This seal **161** is also closable down to seal the guidewire lumen **158**.

[0542] It will be appreciated that the guidewire lumen **158** can be provided as any suitable passageway through the filter **150**. The guidewire lumen **158** does not have to be located along the central axis of the filter **150**. The guidewire lumen **158** may be radially offset from the longitudinal axis of the filter **150**.

[0543] When the guidewire **30** is extended through the guidewire lumen **158**, the seals **160, 161** self-close around the guidewire **130** to prevent emboli flowing through the guidewire lumen **158**. Upon removal of the guidewire **130** from the guidewire lumen **158** while the filter **150** is deployed in the vasculature, the seals **160, 161** self-close down to completely close off the guidewire lumen **158**.

[0544] In this manner, the seals **160, 161** ensure that no blood flow potentially carrying harmful embolic material can pass through the guidewire lumen **158**. All blood flows into the filter body through the inlet openings and out of the filter body through the small outlet openings, thereby trapping and safely retaining the undesired embolic material within the filter **150**.

[0545] After an embolic protection filter has been delivered over a guidewire and deployed in a vasculature, it is not always possible to withdraw the guidewire from the vasculature before collapsing and withdrawing the filter from the vasculature.

[0546] However in some cases it may be necessary to withdraw the guidewire over which the filter was delivered while leaving the filter deployed in the vasculature.

[0547] Examples of when this need may arise are:

[0548] when a high torque guidewire is used to facilitate filter delivery and deployment, and a stiffer guidewire is subsequently used to provide additional support during delivery and deployment of a stent;

[0549] when a guide catheter has prolapsed;

[0550] when a guidewire is withdrawn into a guide catheter to accelerate rate of resolution of a spasm.

[0551] When this need does arise, the filter **50** of the invention may be used to filter potentially harmful emboli from a vasculature when the guidewire is withdrawn, while the filter remains deployed in the vasculature, as illustrated in FIGS. **93** to **110**.

[0552] A first guidewire **130** is introduced into and advanced through the vasculature **121** to cross the treatment location **122** (FIG. **93**), and the filter **150** is delivered through the vasculature **121** and deployed distally of the treatment location **122** (FIGS. **94** to **97**), in a manner similar to that described previously.

[0553] In the outwardly extended configuration, the deployed filter **150** is retained in position in the vasculature **121** against substantial longitudinal movement by the radial apposition force of the filter body against the wall of the vasculature **121**. The first guidewire **130** can thus be withdrawn from the guidewire lumen of the filter **150**, and completely withdrawn from the vasculature **121** without disturbing the outwardly extended configuration of the filter **150** in the vasculature **121**.

[0554] The deployed filter **150** is retained in position in the vasculature **121** against substantial longitudinal movement by means of the radial apposition force exerted by the filter support on the filter body and the vasculature wall, as described previously.

[0555] A second guidewire **140** is then introduced into the vasculature **121** and advanced through the vasculature **121** until the second guidewire **140** crosses the desired treatment location **122**. The tip of the second guidewire **140** is guided towards the proximal end of the guidewire lumen by engagement of the guidewire tip with the funnel **151**, and the second guidewire **140** is then lead through the guidewire lumen.

[0556] A stent **136** may then be delivered through the vasculature **121**, and deployed at the treatment location **122** using the stent delivery catheter **135**. In this case, the stent delivery catheter **135** passes over the second guidewire **140**. After completion of the interventional procedure, the retrieval catheter **120** is advanced to cross the stent **136** and the treatment location **122**, and the tip **125** is engaged with the filter **150**. As the tip **125** passes through the funnel **151**, the funnel **115** is caused to collapse down to the collapsed configuration. The filter **150** is then collapsed and retrieved into the retrieval catheter **120** and withdrawn from the vasculature **121**. Upon collapse of the filter **150**, the apposition of the filter with the vasculature **121** is released.

[0557] The filter **150** ensures any embolic material generated during the interventional procedure is captured and safely removed from the vasculature **121**.

[0558] The second guidewire **140** may be of a different diameter, or have different material properties to the first guidewire **130**. It may thus be easier or more suitable for the clinician to advance the stent delivery catheter **35** over the second guidewire **140** rather than over the first guidewire **130**. For example, it is sometimes the case that a high torque guidewire **130** is used to facilitate filter delivery and deployment, and a stiffer guidewire **140** is used subsequently to provide additional support during delivery and deployment of a stent.

[0559] In some cases, it may be necessary or desirable to withdraw the second guidewire **140** from the filter **150** and

the treatment location **122** after deployment of the stent **136**, and then to advance a third guidewire through the vasculature **121** to the filter, the retrieval catheter **120** then being advanced over the third guidewire to retrieve the filter **150**. This invention enables such a procedure to be carried out.

[0560] Furthermore withdrawing a guidewire into a guide catheter may accelerate the resolution of spasm and reduce the risk of ischaemia.

[0561] Referring to FIGS. **111** to **114**, there is illustrated another retrieval catheter according to the invention, which is similar to the retrieval catheter of FIGS. **190** to **192**. In this case, the catheter body **23** defines a guidewire lumen **151** radially offset from the coupling member **24**. The guidewire lumen **151** extends through only part of the catheter body **23** to facilitate passage of the catheter body **23** over a guidewire, such as the guidewire **140**, in a rapid exchange manner.

[0562] In use, the retrieval catheter **150** may be used to retrieve the filter **1** deployed in the vasculature **21**.

[0563] In one possible procedure, the second guidewire **140** is not led through the guidewire lumen **12** of the filter **1**. Instead the second guidewire **140** is advanced until the guidewire **140** has crossed the treatment location and the guidewire tip is proximally of the filter **1** (FIG. **113**). The filter **1** is then retrieved into the catheter body **23**. During this procedure the retrieval catheter **150** may be advanced distally off the end of the guidewire **140**.

[0564] FIG. **115** illustrates another filter **170** according to the invention. In this case, the funnel **151** is mounted to the filter **170** distally of the inlet end of the filter **170**, so that the funnel **151** is located at least partially within the filter **170**.

[0565] It will be appreciated that the receiver may be detachably mounted to the filter. For example, the receiver may be mounted to the filter after deployment in a vasculature, and/or may be detached from the filter before retrieval of the filter from a vasculature.

[0566] In addition, the receiver may be radially offset from the longitudinal axis of the filter.

[0567] Referring to FIGS. **116** and **117**, there is illustrated another filter **180** according to the invention. The funnel is provided, in the case of filter **180**, by sloping walls **181** of the filter body at the inlet end. As the guidewire **130** is advanced to the filter **180**, the tip of the guidewire **130** meets the sloping walls **181** of the filter body and is guided distally inwardly towards the proximal end of the guidewire lumen. In this manner, the sloping walls **181** enable the guidewire **130** to be easily and quickly threaded into the guidewire lumen.

[0568] The angle of inclination α of these sloping walls **181** can be altered, as indicated in FIG. **117**, to suit the characteristics of the interventional procedure, and/or the vasculature, and/or the guidewire.

[0569] The large inlet openings enable substantially unrestricted flow into the filter body, and the sloping walls **81** may be radiopaque material to aid guidewire passage.

[0570] FIG. **118** illustrates a further filter **190** according to the invention. In this case, the filter **190** has a guidewire aperture **192** for passing the filter **190** over the guidewire **130**, and the filter **190** has a single, large inlet opening **191**

at the inlet end of the filter **190**. The single, large inlet opening **191** provides no resistance to blood flow into the filter body.

[0571] The sloping walls **192** at the outlet end of the filter **190** provides the funnel, in this case, to guide the guidewire **130** towards the guidewire aperture **192**.

[0572] It will be appreciated that the outlet openings are smaller, in this case, than the guidewire diameter, thus the guidewire **130** does not snag or pass through the outlet openings but instead the guidewire **130** is guided distally inwardly to the guidewire aperture **192**.

[0573] The filter **90** may have a guidewire aperture **112** for passing the filter **90** over the guidewire **30**, and the filter **90** has a single, large inlet opening **91** at the inlet end **4** of the filter **90**. The single, large inlet opening **91** provides no resistance to blood flow into the filter body **2**.

[0574] The sloping walls **190** at the outlet end of the filter **190** provides the funnel, in this case, to guide the guidewire **130** towards the guidewire aperture **192**, as illustrated in FIGS. **119** and **120**.

[0575] It will be appreciated that the outlet openings are smaller, in this case, than the guidewire diameter, thus the guidewire **130** does not snag or pass through the outlet openings but instead the guidewire **30** is guided distally inwardly to the guidewire aperture **192**.

[0576] As illustrated in FIGS. **119** to **121** the filter **190** further comprises a distal seal at the guidewire aperture **192** in the form of an elastomeric self-sealing valve **400**. The valve **400** has co-operating flaps which meet centrally to close off the guidewire aperture **192** when the guidewire is not extended through the aperture **192**, as illustrated in FIGS. **119** and **121**. As the guidewire is pushed through the guidewire aperture **192**, the flaps of the valve **400** are forced apart to permit passage of the guidewire **130**, as illustrated in FIG. **120**.

[0577] It will be appreciated that the valve **400** could alternatively be provided in the form of four, two, or any other number of co-operating flaps.

[0578] Referring to FIGS. **122** to **127** the guidewire exit hole may be sealed with a thin flexible membrane **401** which can withstand any pressure differential across the filter but can be deformed by the guidewire tip to open the seal/membrane. Various options are possible such as those illustrated in FIGS. **123** to **126**.

[0579] Another option is to provide a seal in the form of an invertible flexible tube **402**. The tube may have slits **403** for additional flexibility. FIG. **128** shows an initial guidewire in position, FIG. **129** shows the wire removed and the tube collapsed, sealing the hole. In FIG. **130** a new wire is shown being advanced through the filter, the advancing of the wire pushing the tube out of the filter neck and forming a seal with the new wire as illustrated in FIG. **131**. The tube may be slits or slots for added flexibility as illustrated in FIG. **132**.

[0580] The guidewire exit hole may also be sealed by a flap valve or the like. Referring to FIGS. **133** to **135** a closure flap **410** is hingedly connected to the filter **411** by a curved lever **412**. The hinge point **413** is stepped back proximally from the flap **410** so that the pressure drop across the flap

410 does not cause the flap **410** to open. The flap **410** is opened against the biasing of the lever **412** on insertion of a guidewire **415** as illustrated in FIGS. **134** and **135**.

[**0581**] It will be appreciated that the hinge may have a range of different constructions. For example, as illustrated in FIG. **136** a hinge **416** may be provided by a flattened wire or a hinge **417** may be formed by a narrowing of the lever as illustrated in FIG. **137**.

[**0582**] In another embodiment illustrated in FIGS. **138** to **140** a distal end **420** of a filter may have a flattened neck section **421** which normally seals a guidewire aperture **422** but which can be opened to facilitate passage of a wire **423**.

[**0583**] A further embodiment is illustrated in FIGS. **141** to **143** in which the filter distal guidewire aperture has a foam-like insert **425** with slits to facilitate deformation of the foam as a guidewire **426** is inserted whilst still maintaining a sealing engagement with the guidewire **426**.

[**0584**] In the invention the retrieval device grips and retrieves the filter. Conventional filters are retrieved by using the guidewire to engage with the filter. This invention describes a retrieval device with one member which engages with and restrains the filter while a second member may envelop the filter. The retrieval device may function in the absence of a guidewire so that the filter can be retrieved even if the user has removed the guidewire and failed to replace it. This retrieval process may involve three stages: 1) Engage with the filter, 2) Decouple filter from vessel, 3) Retrieve the filter. Alternatively the retrieval may involve two stages: 1) Engage with the filter, 2) Retrieve the filter.

[**0585**] The retrieval process is simple and reliable. The snare (or loop or lasso) designs described provide one of the most reliable and versatile methods. There is preferably a feature on the filter with which this snare will engage easily. This feature and the snare loop are preferably radiopaque for ease of visibility and positioning. For example a large radiopaque ball (or shepherds crook) inside the filter may be pulled proximal to the filter when snared and wrapped down.

[**0586**] Referring in particular to FIGS. **144** to **146**, there is illustrated a retrieval catheter **620** according to the invention. The retrieval catheter **620** is suitable for retrieving a filter, deployed in a vasculature **621** distally of a treatment location **622**, such as a region of stenosis.

[**0587**] The catheter **620** comprises an outer catheter body **623** and a coaxial inner coupling member **624**, the coupling member **624** having means for coupling to the filter especially a filter deployed in the vasculature **621** to be retrieved.

[**0588**] The coupling means is provided, in this case, by an arrow-head shaped tip **625** on the coupling member **624**. The tip **625** has two male fingers **626** for engagement with two corresponding female recesses **627** on the filter **1**.

[**0589**] The male fingers **626** are moveable between a low-profile configuration and an outwardly protruding configuration for engagement with the filter. In this case, the fingers **626** are of a resilient material, and are biased towards the outwardly protruding configuration.

[**0590**] During introduction of the retrieval catheter **620** through the vasculature **621**, the tip **625** protrudes only partially distally of the distal end of the catheter body **623**, so that the resilient fingers **626** are maintained in the

low-profile configuration. The protruding tip **625** prevents snagging of the open mouth of the catheter body **623** against any protruding parts of the vasculature wall. In addition the tip **625** tapers distally inwardly for a smooth crossing profile.

[**0591**] When the retrieval catheter **620** has crossed the treatment location **622**, the coupling member **624** is moved distally relative to the catheter body **623**, to release the resilient fingers **626** to move to the outwardly protruding configuration. The coupling member **624** is then moved further distally into the filter until the fingers **626** engage with the recesses **627** of the filter.

[**0592**] The recesses **627** may be defined in a more pronounced manner by providing inwardly protruding steps or abutments on the proximal end of the filter support against which the fingers **626** may engage.

[**0593**] The catheter body **623** is next moved distally relative to the engaged filter **1** by maintaining the position of the coupling member **624**, the distal end of the catheter body **623** is engaged with the proximal end of the filter body, the catheter body **623** is further advanced and thus the coupled filter **1** is collapsed down releasing the apposition force and is retrieved into the catheter body **623**. When the collapsed filter **1** has been fully retrieved into the catheter body **623**, the retrieval catheter **620** is withdrawn with the filter **1** from the vasculature **621**.

[**0594**] The coupling member **624** of the retrieval catheter **620** enables a deployed medical device, such as the filter **1**, to be retrieved into the retrieval catheter **620** with any retained embolic material within the filter **1** without requiring a step, or a clamp or any special stop features on the guidewire. Thus the retrieval catheter **620** enables the filter **1** to be used in combination with any standard guidewire.

[**0595**] In addition, it is not necessary to retract the guidewire to facilitate retrieval of the filter **1**.

[**0596**] In certain circumstances if the guidewire was withdrawn from the deployed filter **1** it would still be possible to retrieve the filter **1** using the retrieval catheter of the invention. This could speed up the overall procedure. Also in some cases it may be difficult to recross the filter **1** with a guidewire. Furthermore by obviating the need to recross the filter **1** with a guidewire, the possibility of a spasm being caused is minimised.

[**0597**] FIGS. **152** to **165** illustrate the embolic protection filter **1** and the retrieval catheter **620** according to the invention, in use.

[**0598**] A guidewire **630** is introduced into and advanced through the vasculature **621** until the guidewire **630** crosses the desired treatment location **622**. A delivery catheter **631** is then used to deliver the embolic protection filter **1** through the vasculature **621** over the guidewire **630**, the filter **1** being housed within a distal pod **632** of the delivery catheter **631** in the collapsed configuration.

[**0599**] The filter **1** may in one case be loaded into a delivery catheter **631** as described in International patent applications Nos. PCT/IE01/00052 and PCT/IE01/00053, the relevant contents of which are incorporated herein by reference. It will be appreciated that other loading alternatives are also possible.

[**0600**] When the distal pod **632** has been advanced to a desired site distal to the treatment location **622**, the pod **632**

is moved proximally relative to an inner pusher to deploy the filter 1 out of the pod 632 into the outwardly extended configuration, as described in further detail in International patent applications Nos. PCT/IE01/00052 and PCT/IE01/00053. After complete deployment of the filter 1, the delivery catheter 631 is withdrawn from the vasculature 621 (FIG. 11).

[0601] In the outwardly extended configuration the filter 1 is in apposition with the vasculature 621, thereby preventing blood flow from bypassing the filter 1 between the filter 1 and the vasculature 621. The radial apposition force of the filter support against the filter body and the wall of the vasculature 621 retains the filter 1 in position against substantial longitudinal movement, even if the guidewire 630 is moved or indeed removed. In this way the filter 1 is prevented from migrating downstream in the vasculature 621.

[0602] An interventional procedure is then carried out at the treatment location 622. In the case illustrated, the interventional procedure is a stenting procedure using a self-expanding stent. However, a range of procedures are possible as alternatives to, or in addition to stenting, for example a balloon angioplasty procedure, a balloon-expandable stenting procedure, an atherectomy procedure, a lysis.

[0603] A stent delivery catheter 635 is used to deliver a stent, such as a self expanding stent 636, through the vasculature 621, the stent 636 being held in a collapsed configuration by a restraining sheath 637 of the stent delivery catheter 635.

[0604] When the stent delivery catheter 635 has been advanced to the treatment location 622, the sheath 637 is moved proximally relative to an inner body 638 of the catheter 635 to facilitate deployment of the stent 636 at the treatment location 622.

[0605] After complete deployment of the stent 636, the stent delivery catheter 635 is withdrawn from the vasculature 621 leaving the deployed filter 1 and the deployed stent 636 in the vasculature 621.

[0606] Any embolic material generated during delivery or deployment of the stent 636, or during withdrawal of the stent delivery catheter 639 is captured and safely retained in the deployed filter 1.

[0607] After completion of the interventional procedure, the retrieval catheter 620 is introduced into the vasculature 621, and advanced through the vasculature 621 until the stent 636 and the treatment location 622 have been crossed.

[0608] The filter 1 is simultaneously collapsed and retrieved into the catheter body 623 of the retrieval catheter 620 and with it the captured embolic material, by engaging the tip 625 with the filter 1, and then advancing the catheter body 623 distally over the coupling member 624 and the engaged filter 1.

[0609] Upon collapse of the filter 1, the apposition of the filter 1 with the vasculature 621 is released.

[0610] When the filter 1 has been fully collapsed and retrieved into the retrieval catheter 620, the retrieval catheter 620 with the collapsed filter 1 and retained emboli therein are withdrawn from the vasculature 621, leaving the deployed stent 636 in place at the treatment location 622 in the vasculature 621.

[0611] In this way, the filter 1 may be used to capture and safely remove any embolic material which has been generated during the interventional procedure.

[0612] An expandable balloon may be provided on the filter to enhance the outward radial force on the vasculature wall to retain the filter in position against substantial longitudinal movement. In use, the balloon may be inflated after deployment at the desired site in the vasculature to effectively anchor the filter in position. The balloon may be subsequently deflated before retrieval of the filter.

[0613] FIGS. 164 and 165 illustrate another embolic protection filter 300 according to the invention. The filter 300 comprises a capture tether 301 which extends externally of the filter body 2 from a proximal ring 302, to which the tether 301 is fixed, to a distal capture hoop 303. The capture hoop 303 is located around the distal core at the outlet end 5 of the filter 300 when the filter 300 is in the outwardly extended configuration, as illustrated in FIG. 164. The capture hoop 303 is slidable over the filter body. To collapse and retrieve the filter 300 into the retrieval catheter 20, the coupling member 24 engages the capture tether 301 and causes the capture hoop 303 to move proximally. The coupling member 24 may be engaged with the capture tether 301 using a hook, or loop, or any other suitable coupling means, as described previously. In this manner the filter 100 is compressed for retrieval into the catheter body 23, as illustrated in FIG. 165.

[0614] The coupling means may alternatively be provided by a male member in the form of a hook 700, as illustrated in FIG. 166 for hooking around a receiver on the filter 1. The hook 700 may be used to couple the coupling member 24 to any suitably configured embolic protection filter.

[0615] For example, an embolic protection filter 710, illustrated in FIGS. 168 and 169, has a tether arm 711 at a proximal end of the filter 710 around which the hook 700 may be extended to couple the deployed filter 710 with the coupling member 24 and thereby facilitate retrieval of the filter 710 into the catheter body 23.

[0616] FIGS. 170 to 173 illustrate further embolic protection devices 720, 725, 730 according to the invention.

[0617] The filter 720 of FIG. 170 has three tether arms 721 which extend radially inwardly from the filter body 2 to meet at a central point 722. The hook 700 may be extended around any one of the tether arms 721 to couple the coupling member 24 to the filter 720. This tether arrangement enables the filter 720 to be retrieved with a central, axial pull force.

[0618] In the filter 725 of FIG. 172, the three tether arms 726 extend radially inwardly and distally to the central point 727. In this manner the central point 727 is stepped back distally from the single, large inlet opening 6 to minimise the possibility of embolic material becoming caught or hung up on the tether arms 726.

[0619] The filter 730 of FIG. 173 has a central ring 332 to which the tether arms 331 are fixed.

[0620] FIGS. 174 to 178 illustrate the embolic protection filter 710, being retrieved into the catheter body 24 using grasping jaws 906. In this case, the jaws 906 comprise serrated edges 750 to achieve a secure grasping of the tether arm 711. In this manner, the filter 710 may be coupled to the coupling member 24 and retrieved into the catheter body 23.

The retrieval catheter **905** is withdrawn from the vasculature after retrieving the filter **710** leaving the guidewire **30** remaining in the vasculature.

[0621] The tether arms of any of the above described embodiments may be mechanically attached at the central point, and/or at the central ring, and/or to the filter body **2**, for example by bonding, or welding, or brazing. Alternatively the tether arms may be provided integral with the mesh/membrane of the filter body **2**. The tether arms could also be provided as a fibre from such a mesh.

[0622] In the embolic protection filter **410** of FIG. **179** the tether arm **411** is located within the filter **410**. To couple the coupling member **24** to the filter **410**, the hook **100** is extended into the filter **410** and hooked around the tether arm **411**.

[0623] In the filter **413** of FIG. **180**, two tether arms **412** are provided. It will be appreciated that any suitable number of tether arms may be provided at either end of an embolic protection filter, and/or within the filter.

[0624] Referring to FIGS. **181** and **182**, there is illustrated another embolic protection filter **500** according to the invention, which is similar to the filter **720**.

[0625] In this case, the filter **500** comprises an inner tubular member **502** to which the three tether arms **501** are fixed. The tubular member **502** defines a guidewire lumen **503** therethrough for passing a guidewire **530** through the tubular member **502** (FIG. **181**).

[0626] The tubular member **502** extends through only part of the filter **500**. As illustrated in FIG. **182**, this enables the guidewire **530** to cross the filter **500** without having to tread the guidewire **530** through the relatively small diameter guidewire lumen **503**.

[0627] This configuration may be particularly advantageous when it is desired to cross the filter **500** with a guidewire while the filter **500** remains deployed in a vasculature. In this circumstance, the distal end cone of the filter body may act as a guide to guide the guidewire **530** through the guidewire aperture **112**.

[0628] The tubular member **502** of the embolic protection filter **510** illustrated in FIG. **183** also extends only partially through the filter **510** to facilitate crossing of the filter **510** with the guidewire **530** without requiring threading of the guidewire **530** through the tubular member **502**.

[0629] It will be appreciated that any other suitable means for coupling the deployed filter **1** with the coupling member **24** of the retrieval catheter **20** may be employed to facilitate retrieval of the filter **1** into the catheter body **23**, for example the coupling member **24** may be provided with one or more female recesses for engagement with one or more corresponding male protrusions on the filter **1**.

[0630] Alternatively a female member on the coupling member **24** may be provided in the form of a loop **701**, as illustrated in FIG. **167**, for looping around a male stub **702** protruding from the filter **1**.

[0631] Referring to FIGS. **184** to **189** there is illustrated another retrieval catheter **905** according to the invention. In this case, the coupling member **24** comprises a pair of jaws **906** at the distal end of the coupling member **24**. The jaws

906 are movable between an outwardly protruding configuration (FIG. **186**) and a low-profile configuration (FIG. **187**) to grasp the filter **1**.

[0632] The jaws **906** are biased towards the low-profile configuration and may be moved outwardly by moving an inner elongate actuator **907** longitudinally distally relative to the jaws **906** to engage elbows **908** on the Jaws **906** and thereby move the jaws **906** outwardly in a camming arrangement (FIG. **186**).

[0633] The jaws **906** define a recessed portion **909a** for co-operation with a protruding neck **909b** on the proximal end of the filter **1** during grasping of the filter **1**, as illustrated in FIG. **187**.

[0634] In use, the retrieval catheter **905** is advanced through the vasculature **21** in the low-profile configuration until the jaws **906** are proximally adjacent to the deployed filter **1**. The actuator **907** is then moved distally relative to the jaws **906** to cam the jaws **906** open, and the opened jaws **906** are advanced until the recessed portion **909a** of the jaws **906** are around the protruding neck **909b** of the filter **1**. By moving the actuator **907** proximally relative to the coupling member **24** the jaws **906** are released to move inwardly to grasp the filter **1** around the neck **909b**. The grasped filter **1** may then be retrieved into the catheter body **23** by moving the catheter body **23** distally relative to the coupling member **24**.

[0635] It will be appreciated that the jaws **906** may grasp any suitable part of the filter **1** to facilitate retrieval. For example, the jaws **906** may grasp the filter **1** at the inlet openings **6**, as illustrated in FIGS. **188** and **189**.

[0636] As illustrated in FIGS. **190** to **191**, the jaws **906** may alternatively be biased outwardly. During advancement of the retrieval catheter **905** through the vasculature **21**, the jaws **906** are restrained in the low-profile configuration by the catheter body **23** (FIG. **190**). To move the jaws **906** outwardly, the coupling member **24** is moved distally relative to the catheter body **23** to release the jaws **906** to spring outwardly (FIG. **191**).

[0637] To subsequently move the jaws **906** inwardly when the recessed portion **909a** of the jaws **906** are around the protruding neck **909b** of the filter **1**, the catheter body **23** is moved distally relative to the coupling member **24** to engage the jaws **906** and move the jaws **906** inwardly to grasp the filter **1** around the neck **909b**. The filter **1** is then retrieved into the catheter body **23** by advancing the catheter body **23** filter distally relative to the coupling member **24** and the grasped filter **1** (FIG. **192**).

[0638] Alternatively, the coupling member **24** may have a magnetic tip **25** for magnetic coupling to an oppositely charged magnetic portion of the filter **1**.

[0639] FIGS. **193** and **194** illustrate another retrieval catheter **940** according to the invention. In this case, the retrieval catheter **940** comprises a second coupling member **941**, which is movable relative to the first coupling member **24**. In this way, the second coupling member **941** may be used to axially elongate an element of the deployed filter **1**, such as the filter support frame **3**, to collapse the filter **1** to the low-profile configuration for retrieval into the catheter body **23**. In this case, the second coupling member **941** acts as a pusher and is movable distally relative to the tip **25**. By

engaging the tip 25 with the filter support 3 and then moving the second coupling member 41 distally to engage a distal end 42 of the filter support 3, the filter support 3 is axially elongated and the filter 1 is collapsed from the outwardly extended configuration of FIG. 194 to the collapsed configuration.

[0640] The collapsed filter 1 may then be retrieved by moving the catheter body 23 distally relative to the tip 25 and the engaged filter 1.

[0641] Referring to FIGS. 195 to 201 there is illustrated another filter retrieval system of the invention. In this case a snare type retrieval is used for a filter 850 with a guidewire 851 extending through a tubular member 852. The tubular member 852 has a projecting head portion 853 with an associated marker band 854 for engagement by a lasso or loop 855 delivered through a retrieval catheter 856 into which the filter is retrieved as illustrated.

[0642] Another embodiment is illustrated in FIGS. 202 to 206 which is used for retrieval of a filter 860 which does not have a tubular member. In this case the filter frame has a snare receiving projection 861 which is engaged by a snare lasso/loop 862 and the filter 860 is retrieved into a retrieval catheter 863, as illustrated.

[0643] FIGS. 207 to 212 illustrate an embodiment in which a filter 870 is used which has a partial tubular member 871 but the guidewire does not extend through the tubular member. This arrangement is similar to that of FIGS. 195 to 201 above and like parts are assigned the same reference numerals. The snare loop is in this case free of the guidewire and may be more easily manipulated. In both cases the snare loop may be rendered radiopaque to facilitate snaring with the filter for retrieval.

[0644] Further retrieval devices are illustrated in FIGS. 213 to 218 in which the retrieval devices have arms 950 which open out when an outer sheath 951 is retracted and thus create a large inlet mouth which can readily trap the filter frame, particularly if radiopaque features such as marker bands are used. When the arms 950 are in position distal to the snare feature of the frame/filter the arms are closed again, for example by re-advancing a sheath 951 which collapses the arms 950 and traps tether feature 952 of the filter, for example behind a step or tooth on the arm(s).

[0645] Referring to FIGS. 219 to 224 the filter frame may have a retrieval feature such as a nodule 960 which may be engaged by a suitable snare such as a snare loop or lasso 961 which is then tightened or simply pulled back to collapse the frame and retrieve the filter. The centering tip 962 may be used to assist guiding of the snare loop.

[0646] Various alternative filter designs with an integral snare feature are possible. For example, in FIGS. 225 and 226 the filter frame has a projecting arm 970 which may be engaged by a snare.

[0647] An expandable engagement member 971 may be used to catch a drawstring type arrangement 972 (FIGS. 227, 228) or to catch internal wires/tethers/fibers/strings of the filter (FIGS. 229, 230).

[0648] Referring to FIGS. 231 and 232 there is illustrated the size of a snare 990 to snare a filter 991. The snare engagable features of the filter in this case are provided by indents 992 in the support arms over which the snare loop 990 is engaged.

[0649] The snaring of a filter of any type is illustrated in FIGS. 233 to 237. In this case the filter 995 is positioned distal to a stent 996 and a snare loop 997 is advanced through the stent to engage the filter as illustrated, allowing the filter to be at least partially collapsed for retrieval.

[0650] In FIGS. 238 and 239 there is illustrated the snaring of a filter 1 as illustrated in FIG. 1 using a snare loop 998.

[0651] A further embolic protection filter 700 according to the invention is illustrated in FIGS. 240 and 241. The filter 700 comprises a collapsible filter support structure 701 and a collapsible filter body 702.

[0652] In the expanded, deployed configuration of FIG. 240, the support structure 701 does not have an inner tubular member to define a guidewire lumen for passing a guidewire 703 through. When the filter 700 is collapsed, the support structure collapses down into a smaller diameter tubular structure, as illustrated in FIG. 241. In this collapsed configuration, the support structure 701 defines the guidewire lumen for the guidewire 703. In this manner the support structure 701 isolates the filter body 702 from the guidewire 703, and thus prevents the filter body 702 from becoming fixed to the guidewire 703 during delivery or retrieval of the filter 700.

[0653] The filter 700 may be retrieved using any suitable means, such as the hooked retrieval catheter (FIG. 242), in a manner similar to that described previously or the hooped retrieval catheter (FIG. 243), in a manner similar to that described previously.

[0654] If it is desired to remove the guidewire 703 from the filter 700 and recross the filter 700 with a second guidewire 704, the guidewire 704 may be threaded through one of the relatively large inlet openings 705 instead of through the relatively small proximal collar 706 of the support structure 701, as illustrated in FIG. 244. This enables a faster and more convenient means of recrossing the filter 700.

[0655] In addition, the distal collar 707 of the filter support structure 701 is spaced proximally of the distal end of the filter 700 to facilitate crossing of the filter 700 with the second guidewire 704 without requiring the guidewire 704 to be threaded through the distal collar 707 (FIG. 244).

[0656] The filter 700 can be retrieved after crossing the filter 700 with the second guidewire 704 using any suitable means (FIGS. 245 and 246).

[0657] Referring to FIGS. 247 and 248, there is illustrated another embolic protection filter 710 according to the invention, which is similar to the embolic protection filter 700 of FIGS. 240 and 241, and similar elements in FIGS. 247 and 248 are assigned the same reference numerals.

[0658] The filter 710 is longitudinally shorter than the filter 700. In addition the filter support structure 701 ends in an open distal mouth 711 in the filter 710 and no distal collar is provided in the filter 710, as illustrated in FIG. 247.

[0659] In the filter 710, the filter body 702 is isolated from the guidewire 703 by the collapsed filter support structure 701 (FIG. 248), in a manner similar to that described previously with reference to FIG. 241.

[0660] The filter 710 may be recrossed by the second guidewire 704 by threading the guidewire 704 through one

of the relatively large inlet openings 705 (FIG. 249), in a manner similar to that described previously with reference to FIG. 244.

[0661] Referring to FIGS. 252 to 256 the position of the filter 1 in the vasculature 21 may be controlled by an abutment 200 on a guidewire 201. By engaging the abutment 200 with an abutment surface on the filter 1, the filter 1 is prevented from moving distally of the guidewire abutment 200. In this manner, the position of the filter 1 in the vasculature 21 may be controlled, if necessary.

[0662] The abutment 200 may be fixedly attached to the guidewire 201 by a suitable means, such as by crimping, before introducing the guidewire 201 into the vasculature 21. Alternatively the abutment 200 may be fixed to the guidewire 201 during deployment of the filter 1.

[0663] As illustrated in FIG. 257 the filter 205 according to the invention may have a tether 206 fixed to the filter 205, extending proximally of the filter 205. The tether 206 may be used by a clinician to control the position of the filter 205 in the vasculature 21 from a location externally of the vasculature 21. The tether 206 may be in the form of a wire, and may be of any suitable material.

[0664] In use, the filter 205 may be deployed over a guidewire 207. If appropriate or necessary, the guidewire 207 may then be withdrawn from the filter 205 and the vasculature 21. The tether wire 206 may then be used as a platform for advancing further devices through the vasculature 21, for example the retrieval catheter 20.

[0665] Referring to FIGS. 258 to 260, there is illustrated another embolic protection filter assembly 115 according to the invention. The assembly 115 comprises a filter and a receiver to guide the guidewire 30 into the guidewire lumen 12. The receiver is provided, in this case, by an approach channel 116 for the guidewire 30 in the form of a lumen in a separate catheter 117. The catheter 117 has one or more inflatable balloons 118 at the distal end of the catheter 117. The shape and/or position of the balloons 118 is configured to ensure that the blood flow through the vasculature 21 will not be occluded upon inflation of the balloon(s) 118. In one case, the catheter 117 has three balloons 118 spaced circumferentially around the catheter 117, as illustrated in FIG. 261. In another case, the catheter 117 has four circumferentially spaced balloons 118 (FIG. 262).

[0666] In use, the catheter 117 is introduced into the vasculature 21 and advanced through the vasculature 21 until the catheter distal end is proximally adjacent the filter 1 (FIG. 56). The balloon 118 is then inflated until the balloon 118 engages the wall of the vasculature 21. By engaging the balloon 118 with the wall of the vasculature 21 the catheter 117 is spaced from the wall of the vasculature 21 to assist in locating the catheter approach channel 116 centrally in the vasculature 21. The guidewire 30 may then be introduced into the channel 116 and advanced through the catheter 117. Because the channel 116 is located centrally in the vasculature 21, the guidewire 30 is guided into the guidewire lumen 12 of the filter 1 as it passes out of the distal end of the channel 116. The balloon 118 may be deflated to a low profile configuration during introduction and withdrawal of the catheter 117 from the vasculature 21.

[0667] It will be appreciated that any number of seals may be provided to prevent embolic material passing through the

guidewire lumen or the guidewire aperture, and the seals may be positioned at any suitable point along the guidewire lumen or the guidewire aperture.

[0668] It will further be appreciated that the receiver may be configured to guide a docking device in the form of a coupling member, such as those described previously, towards the filter for coupling to the filter. In such a manner, the receiver may be used to assist retrieval of the filter. The coupling means may be achieved by numerous alternatives, for example male-female inter-engagement, or magnetic coupling, or hook and eyelet means.

[0669] FIG. 263 illustrates another retrieval catheter 600 according to the invention. The coupling member 24, in this case, has a tubular extension part 601 which extends distally of the hooks 100. In use, the tubular extension 601 may be extended through an embolic protection filter 602 to be retrieved, as illustrated in FIG. 264. The tubular extension 601 in this way defines the guidewire lumen 603 through the filter 602 through which a guidewire 604 may be passed.

[0670] The retrieval catheter 600 is particularly suitable for retrieving filters, such as the filter 602 which do not have an inner tubular member to define a guidewire lumen through the filter 602. Filters which do not have an inner tubular member are liable to becoming fixed against the guidewire 604 when the filter is collapsed down. When this occurs it is no longer possible to retrieve the filter while the guidewire remains in situ in the vasculature.

[0671] By defining the guidewire lumen 603 using the tubular extension 601 of the retrieval catheter 600, this serves to isolate the collapsing filter 602 from the guidewire 604, and thus prevents the filter 602 from becoming fixed to the guidewire 604.

[0672] The tubular extension 601 may be advanced to the distal end of the filter 602 before retrieving the filter 602 into the catheter body 23, as illustrated in FIG. 85.

[0673] Alternatively the tubular extension 601 may be advanced until the tubular extension 601 is distally of the distal end of the filter 602 before retrieving the filter 602 into the catheter body 23.

[0674] The invention is not limited to the embodiments hereinbefore described, with reference to the accompanying drawings, which may be varied in construction and detail.

1. An embolic protection filter having an inlet end and an outlet end, the inlet end having one or more inlet openings sized to allow blood and embolic material enter the filter, and the outlet end of the filter having a plurality of outlet openings sized to allow through passage of blood but to retain undesired embolic material within the filter;

the filter having a guidewire aperture for passing the filter over a guidewire; and

the filter comprising a seal to seal the guidewire aperture.

2. A filter as claimed in claim 1, wherein the seal is self-closing.

3. A filter as claimed in claim 1, wherein the seal is located at a proximal end of the filter, and/or at a distal end of the filter.

4. A filter as claimed in claim 1, wherein the filter has a tubular member extending from the guidewire aperture to define a guidewire lumen through the tubular member.

5. A filter as claimed in claim 4, wherein the tubular member extends through at least part of the filter.

6. A filter as claimed in claim 4, wherein the tubular member is radially offset from the longitudinal axis of the filter.

7. A filter as claimed in claim 1, wherein the seal is an annular member around the guidewire aperture, the annular member being closable down to seal the guidewire aperture.

8. A filter as claimed in claim 7, wherein the annular member is a tube

9. A filter as claimed in claim 7, wherein the annular member comprises a soft membrane.

10. A filter as claimed in claim 7, wherein the annular member comprises two or more circumferentially overlapping flaps.

* * * * *