



US00D839080S

(12) **United States Design Patent**
Iellimo

(10) **Patent No.:** **US D839,080 S**

(45) **Date of Patent:** **** Jan. 29, 2019**

- (54) **STRUCTURAL MEMBER**
- (71) Applicant: **Frazier Industrial Company**, Long Valley, NJ (US)
- (72) Inventor: **Domenick Iellimo**, Forked River, NJ (US)
- (73) Assignee: **Frazier Industrial Company**, Long Valley, NJ (US)
- (**) Term: **15 Years**

6,106,184 A * 8/2000 Daniels F16B 5/025
403/282

6,315,137 B1 * 11/2001 Mulford A47B 57/565
211/193

D481,619 S * 11/2003 Hightower D8/382

D608,183 S * 1/2010 Meyer D8/354

D635,810 S * 4/2011 Boyer D6/566

D639,587 S * 6/2011 Selinger D25/126

D682,069 S * 5/2013 Lehane D8/349

(Continued)

Primary Examiner — Jennifer Rivard
Assistant Examiner — Alison M Otstun
 (74) *Attorney, Agent, or Firm* — Dilworth & Barrese, LLP

(21) Appl. No.: **29/593,178**

(22) Filed: **Feb. 7, 2017**

(51) **LOC (11) Cl.** **08-05**

(52) **U.S. Cl.**
USPC **D8/354**

(58) **Field of Classification Search**
 USPC D8/60, 61, 77, 82, 342, 349, 354, 355,
 D8/356, 367, 382, 396, 499; D25/113,
 D25/114, 119, 120-125, 131, 136, 199
 CPC E04C 3/07; E04C 2003/046; E04B 1/19;
 E04B 2001/1963
 See application file for complete search history.

(56) **References Cited**

U.S. PATENT DOCUMENTS

3,094,197 A * 6/1963 Attwood A47B 96/1408
29/521

3,127,961 A * 4/1964 Frazier A47B 96/1408
52/633

3,769,772 A * 11/1973 Oetiker A47C 17/64
52/646

D285,047 S * 8/1986 Dean D8/349

5,315,803 A * 5/1994 Turner E04B 2/706
248/351

D356,488 S * 3/1995 Gehiere D8/354

D374,579 S * 10/1996 Nilsson D6/709

D378,748 S * 4/1997 Miller D12/223

(57) **CLAIM**

The ornamental design for a structural member, as shown and described.

DESCRIPTION

FIG. 1 is a front perspective view of a structural member showing my new design;
 FIG. 2 is a rear perspective view thereof showing my new design;
 FIG. 3 is a rear view thereof showing my new design;
 FIG. 4 is a front view thereof showing my new design;
 FIG. 5 is a left side view thereof showing my new design;
 FIG. 6 is a right side view thereof showing my new design;
 FIG. 7 is a top view thereof showing my new design;
 FIG. 8 is a bottom view thereof showing my new design;
 and,
 FIG. 9 is a front perspective view thereof, shown in an environment of use.
 The broken lines are shown for the purpose of illustrating environmental subject matter and portions of the article, none of which form part of the claim.
 The article is shown with a symbolic break in its length. The appearance of any portion of the article between the break lines forms no part of the claimed design.

1 Claim, 8 Drawing Sheets

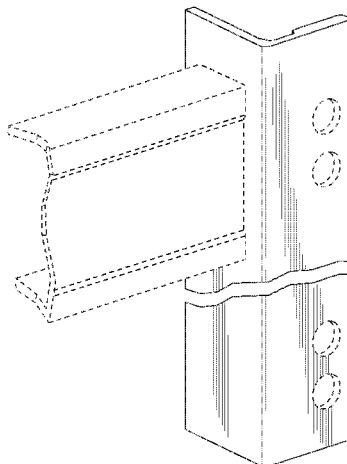

(56)

References Cited

U.S. PATENT DOCUMENTS

D732,708 S * 6/2015 Stauffer D25/133
D777,024 S * 1/2017 Lee D8/396
9,631,366 B2 * 4/2017 Mei E04C 3/122
2006/0254192 A1 * 11/2006 Fennell, Jr. E04B 7/02
52/699
2018/0119409 A1 * 5/2018 Bergeron E04B 1/2403

* cited by examiner

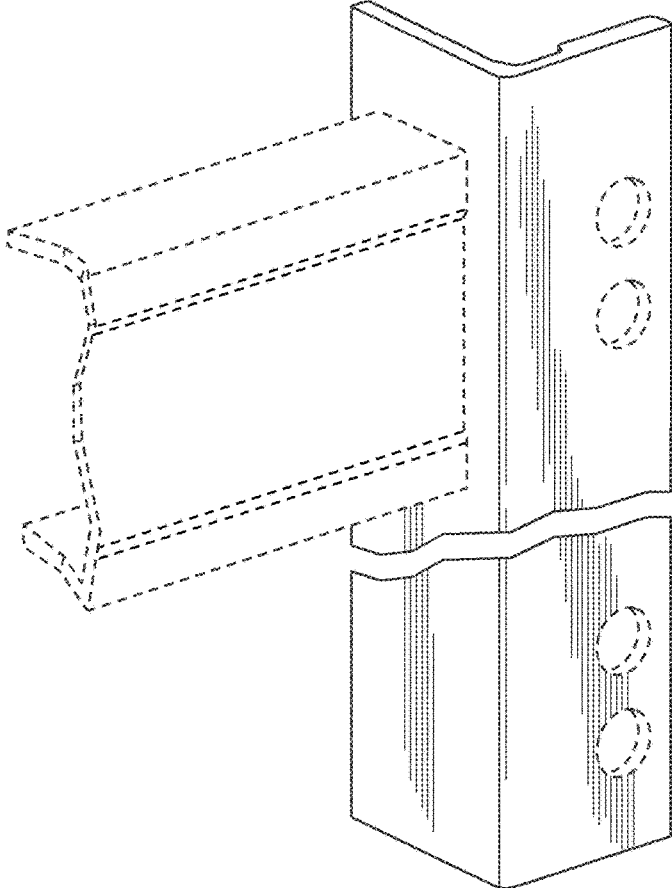

FIG. 1

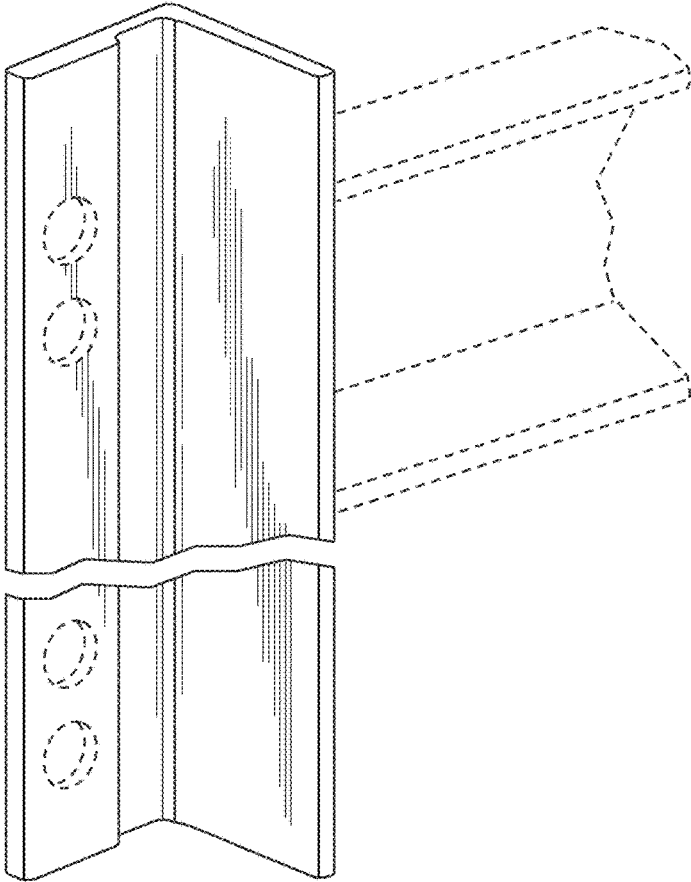

FIG. 2

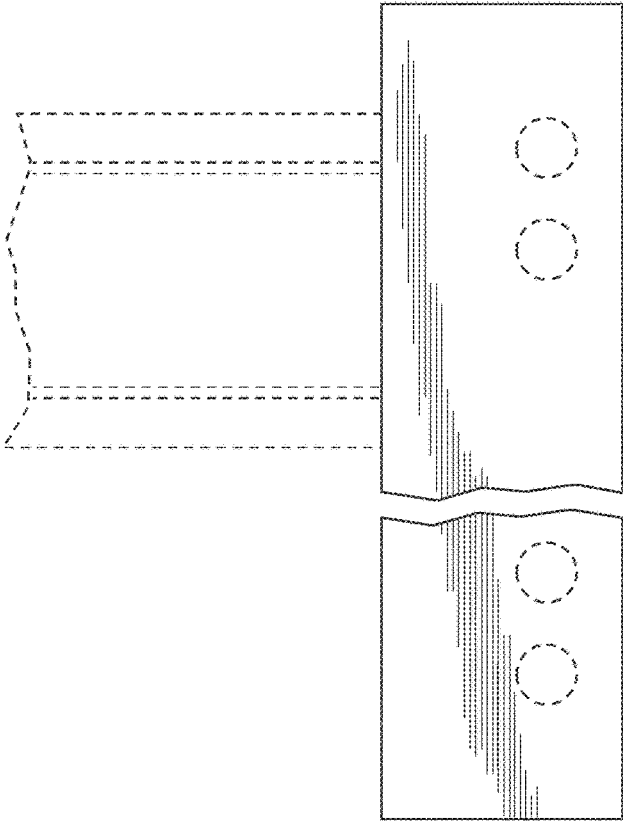

FIG. 3

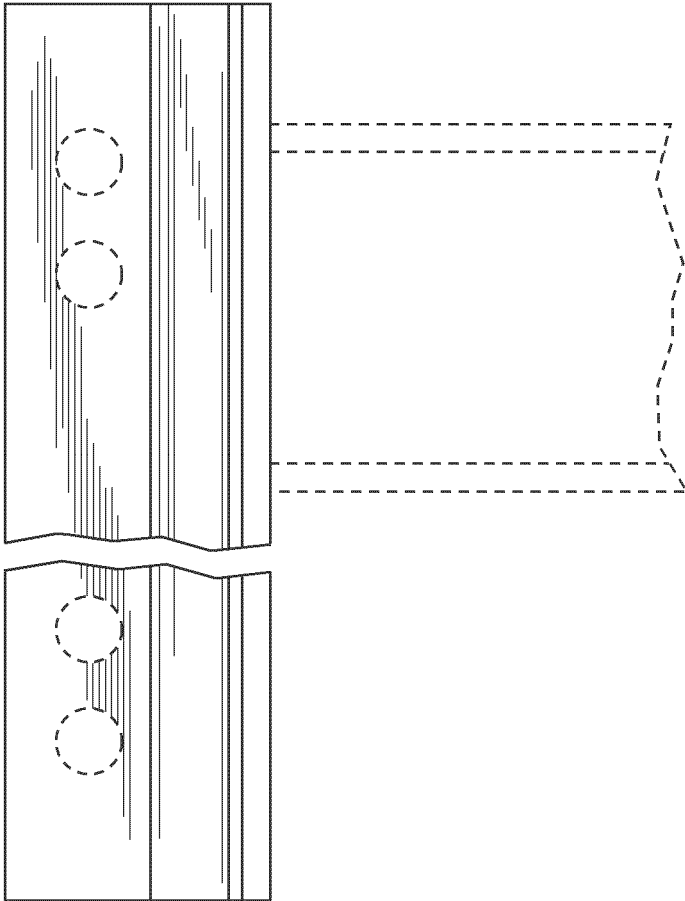

FIG. 4

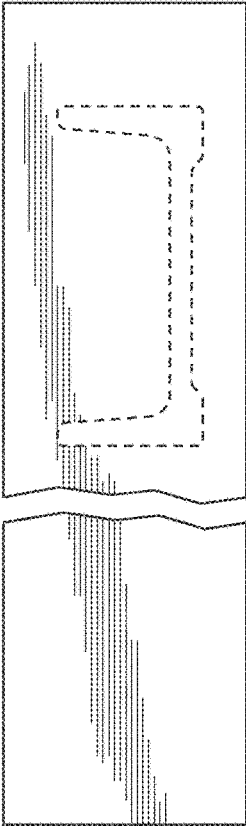

FIG. 5

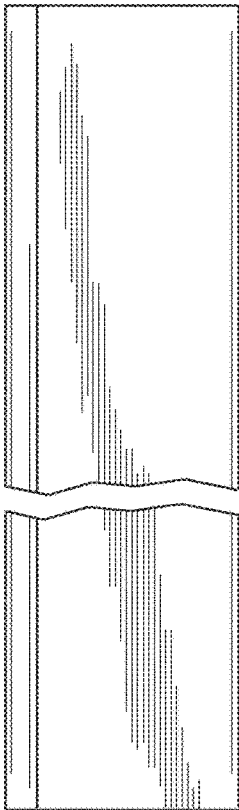

FIG. 6

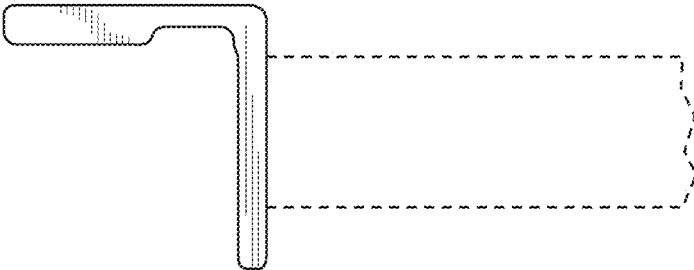

FIG. 7

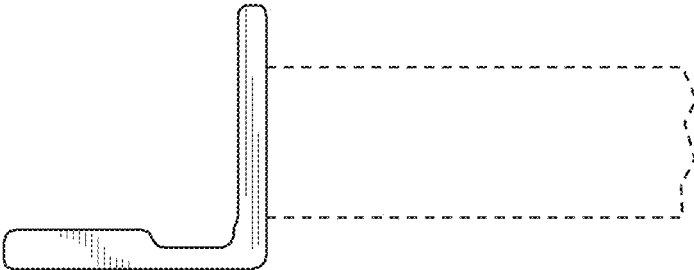

FIG. 8

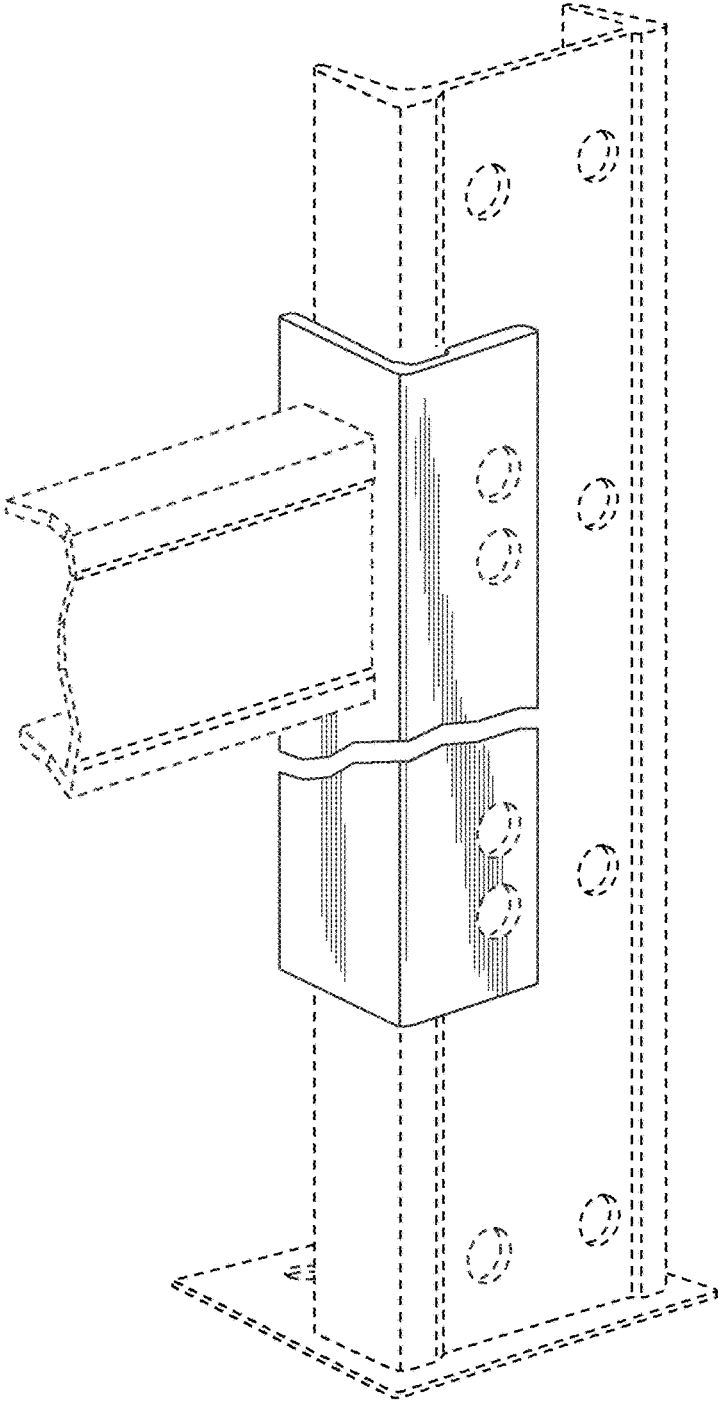

FIG. 9