



US 20060040170A1

(19) **United States**

(12) **Patent Application Publication**  
LIU et al.

(10) **Pub. No.: US 2006/0040170 A1**

(43) **Pub. Date: Feb. 23, 2006**

(54) **FLAT PANEL DIRECT METHANOL FUEL CELL AND METHOD FOR MAKING THE SAME**

(30) **Foreign Application Priority Data**

Aug. 18, 2004 (TW)..... 093124831

**Publication Classification**

(76) Inventors: **Yung-Yi LIU**, Taipei Hsien (TW);  
**James SHANG**, Taoyuan (TW);  
**Yi-Chen Chen**, Taoyuan County (TW)

(51) **Int. Cl.**  
**H01M 4/86** (2006.01)  
**H01M 8/10** (2006.01)  
**H01M 2/08** (2006.01)  
**H01M 8/24** (2006.01)

(52) **U.S. Cl.** ..... **429/44; 429/32; 429/36**

Correspondence Address:  
**NORTH AMERICA INTELLECTUAL  
PROPERTY CORPORATION  
P.O. BOX 506  
MERRIFIELD, VA 22116 (US)**

(57) **ABSTRACT**

A flat panel DMFC (direct methanol fuel cell) includes an integrated cathode electrode sheet, a set of membrane electrode assemblies, an intermediate bonding layer, an integrated anode electrode sheet, and a fuel container base. The integrated cathode/anode electrode sheets are manufactured by using PCB compatible processes.

(21) Appl. No.: **10/908,301**

(22) Filed: **May 6, 2005**

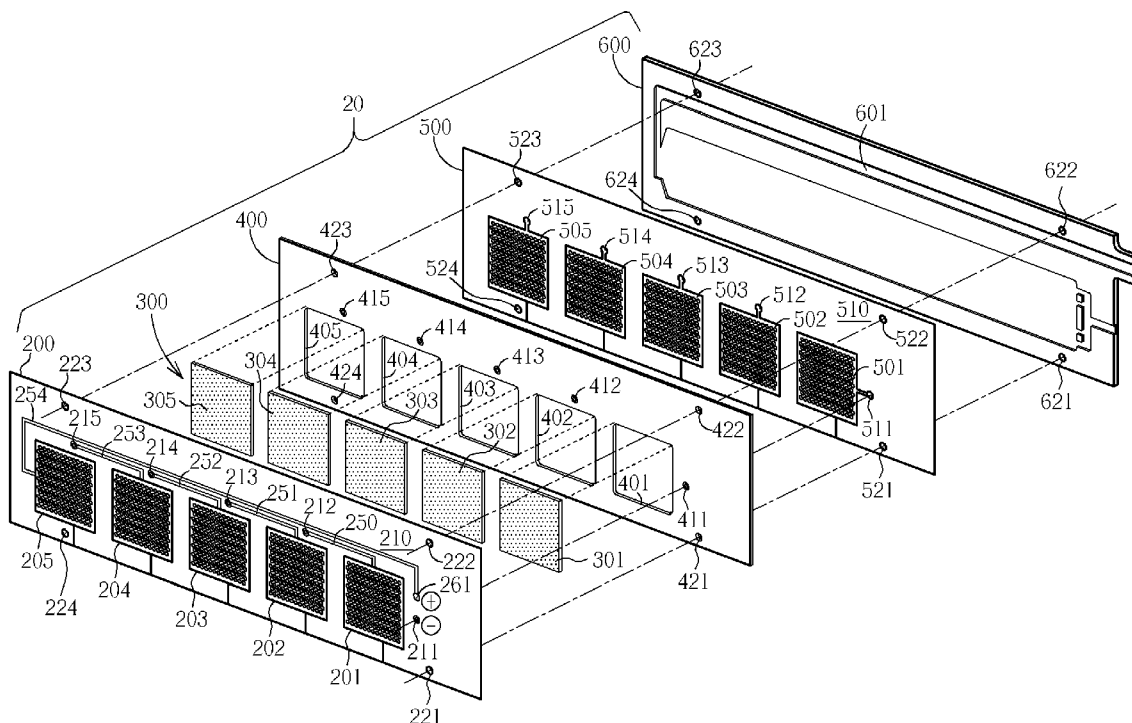

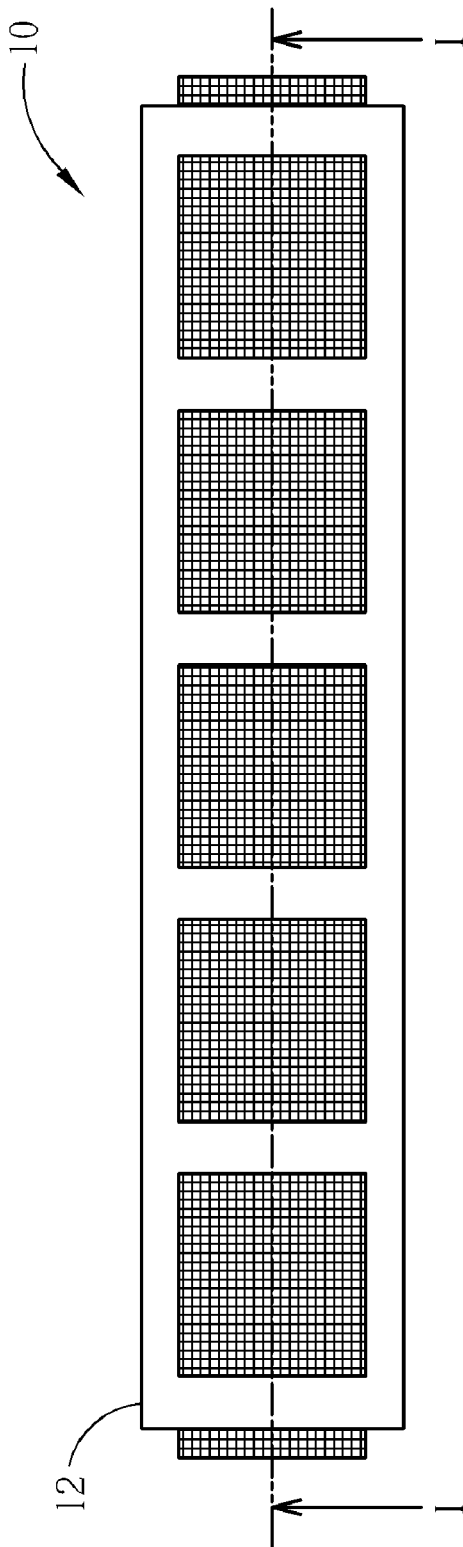

Fig. 1 Prior art

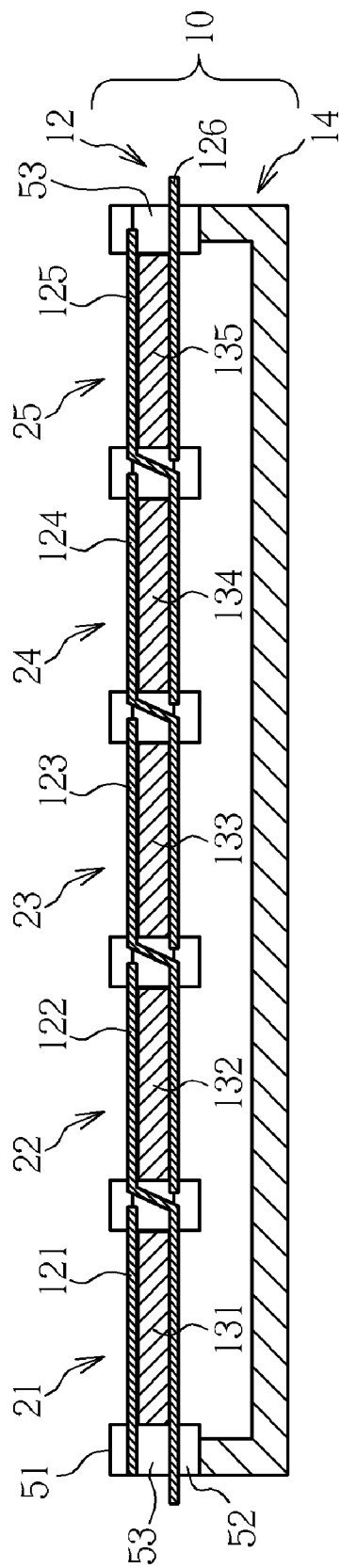

Fig. 2 Prior art

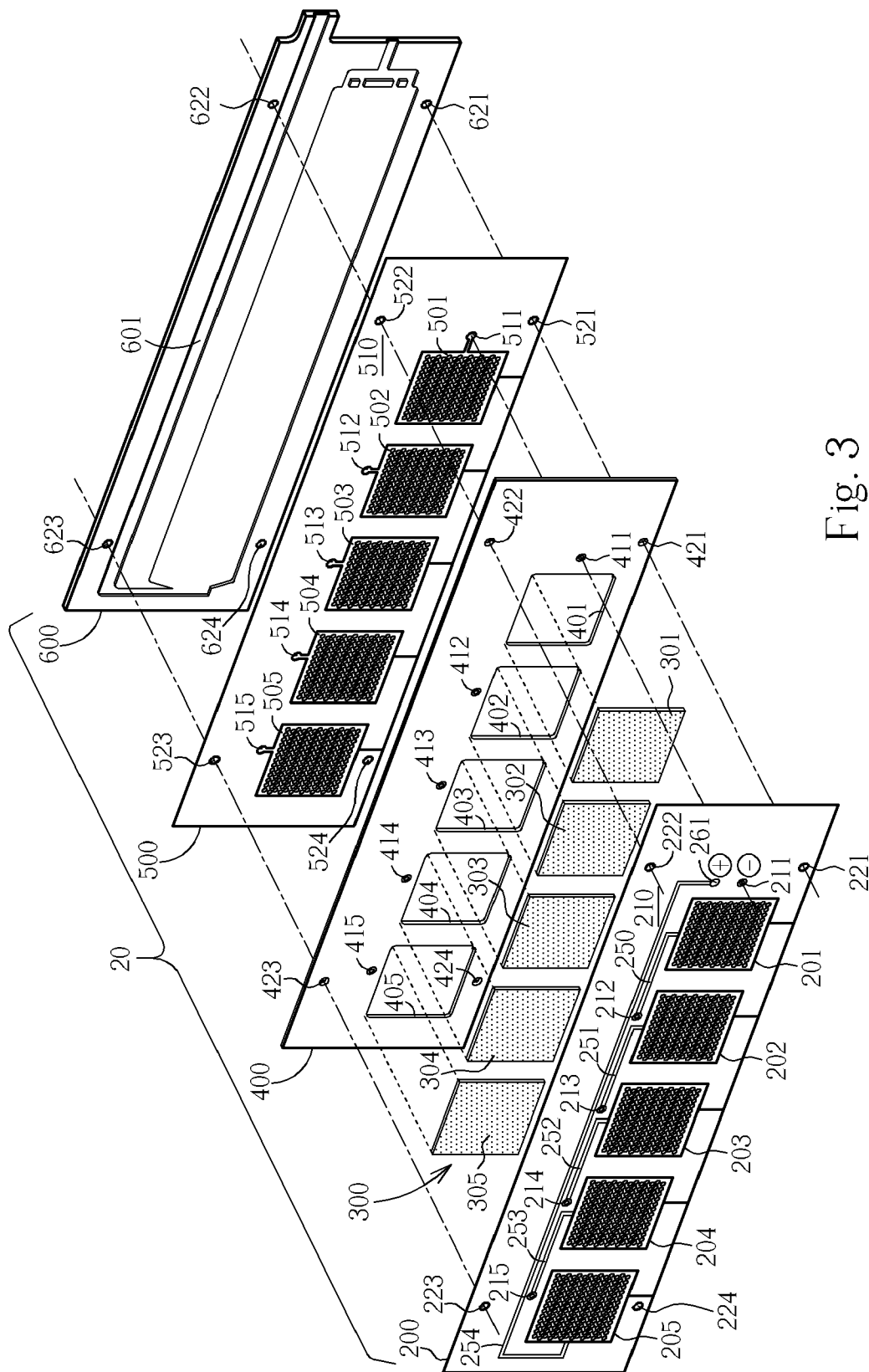

Fig. 3

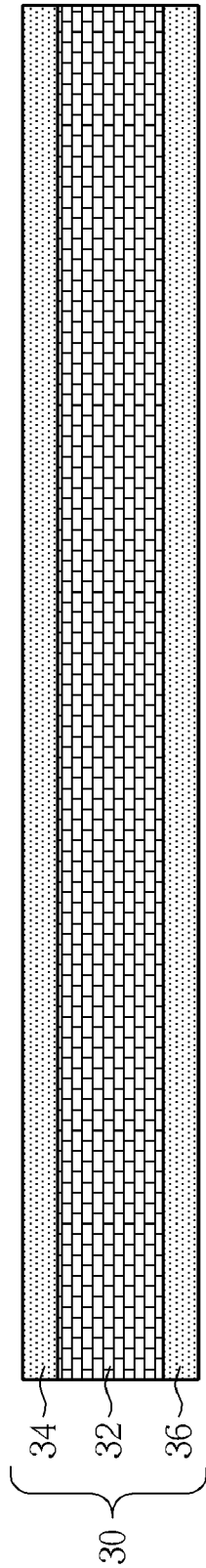

Fig. 4

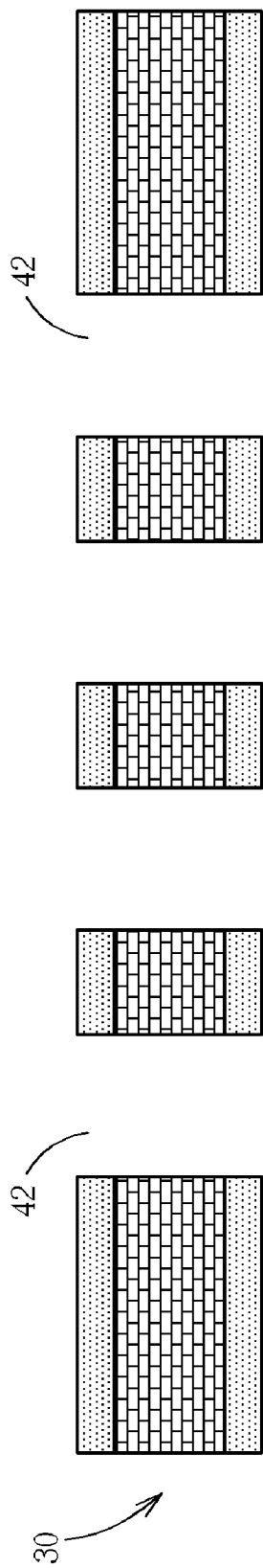

Fig. 5

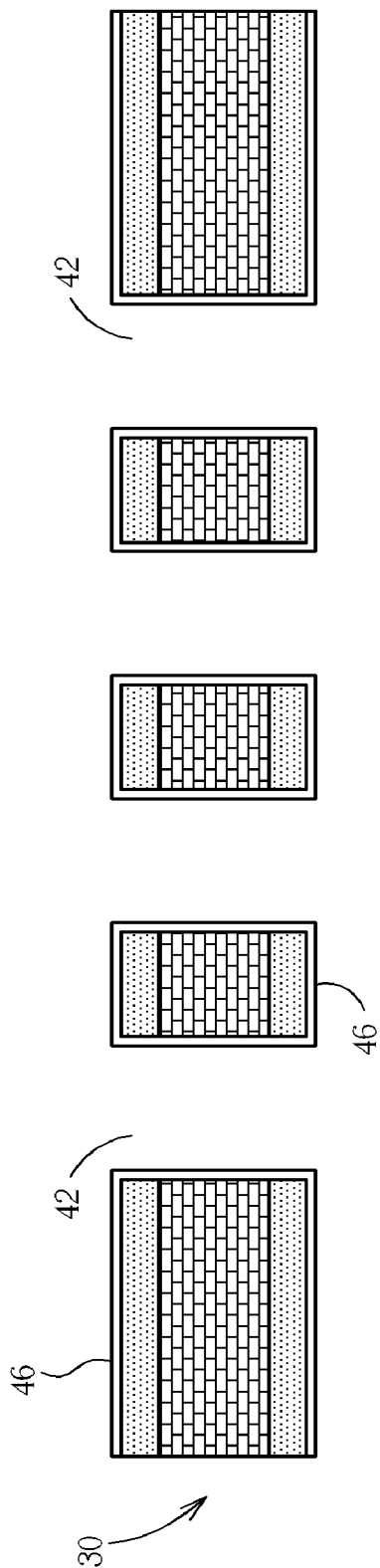

Fig. 6

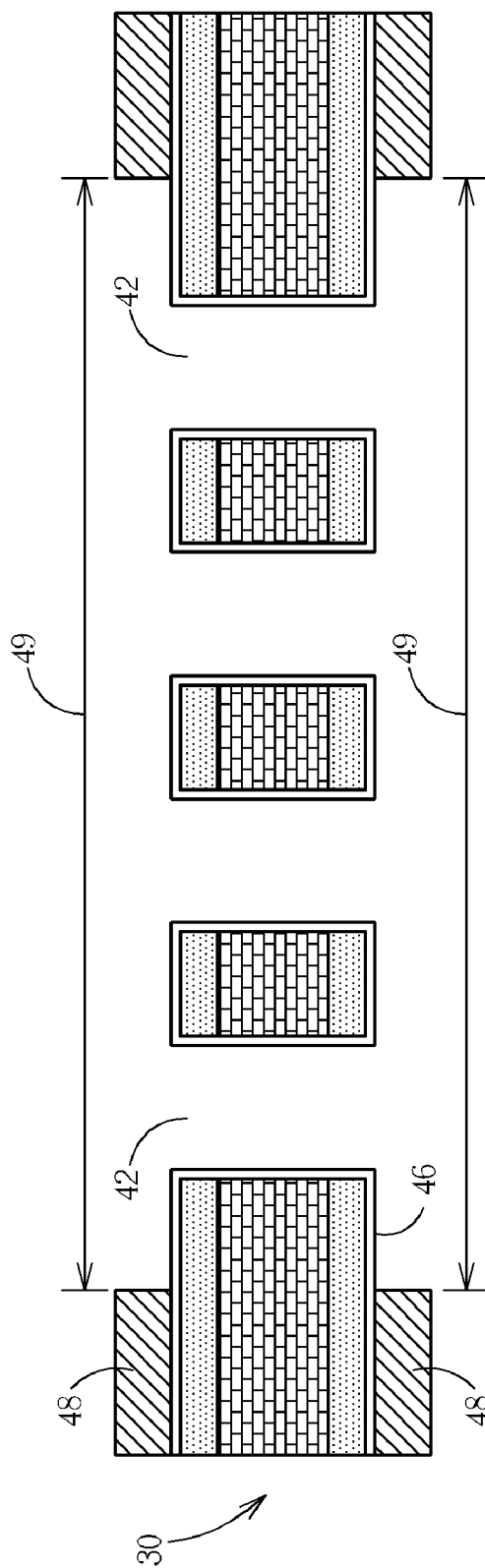

Fig. 7



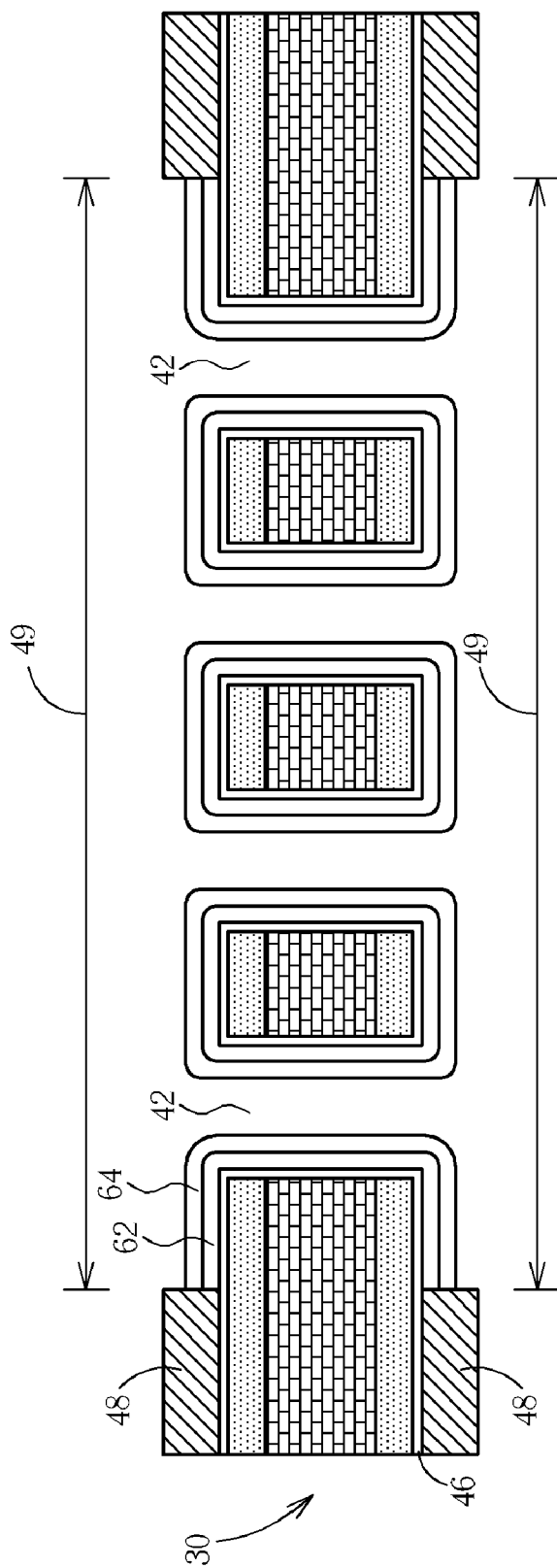

Fig. 8

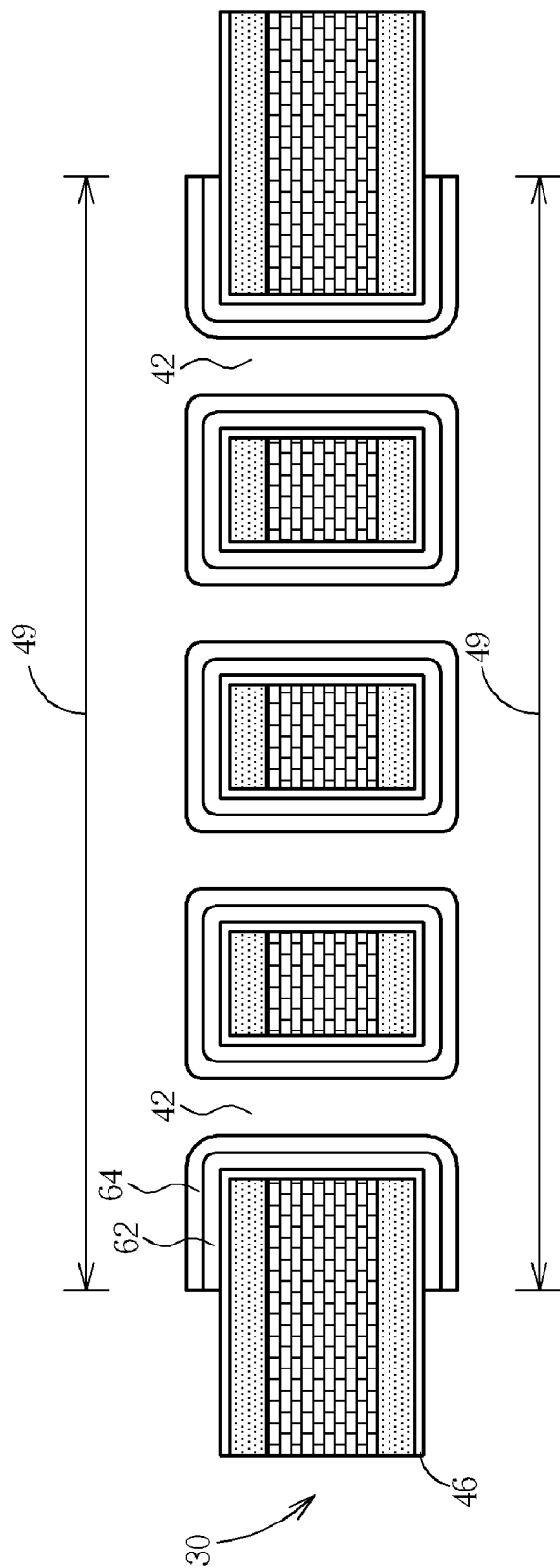

Fig. 9

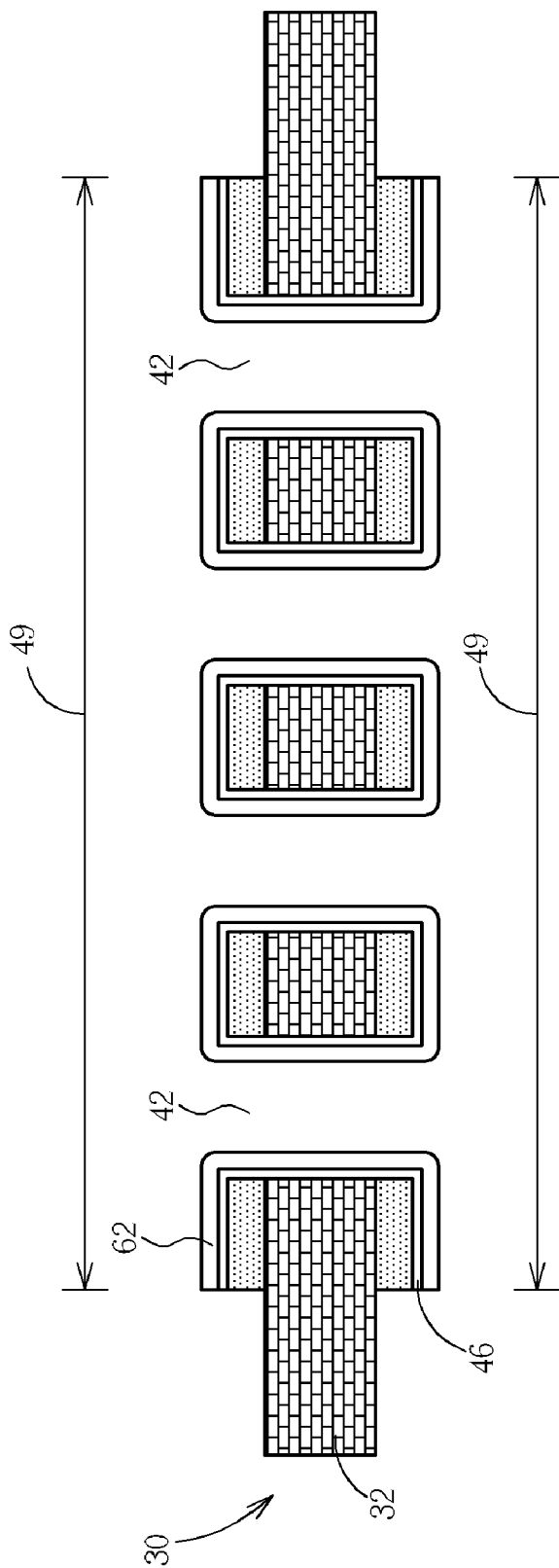

Fig. 10

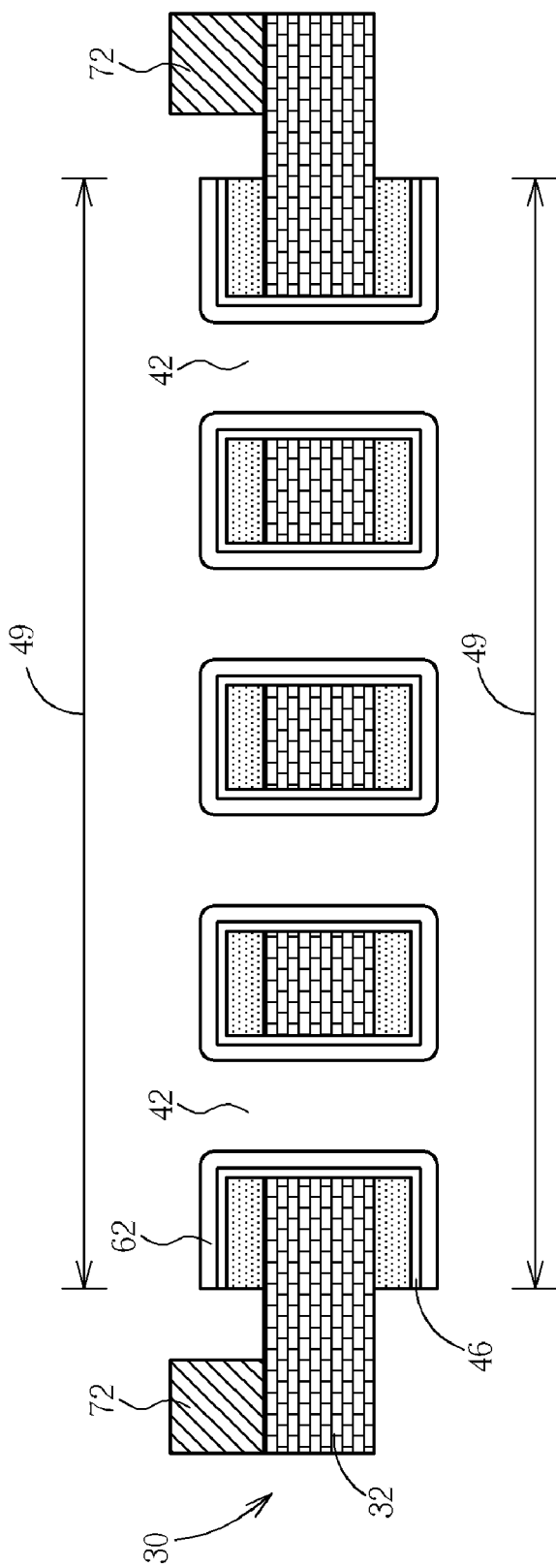

Fig. 11

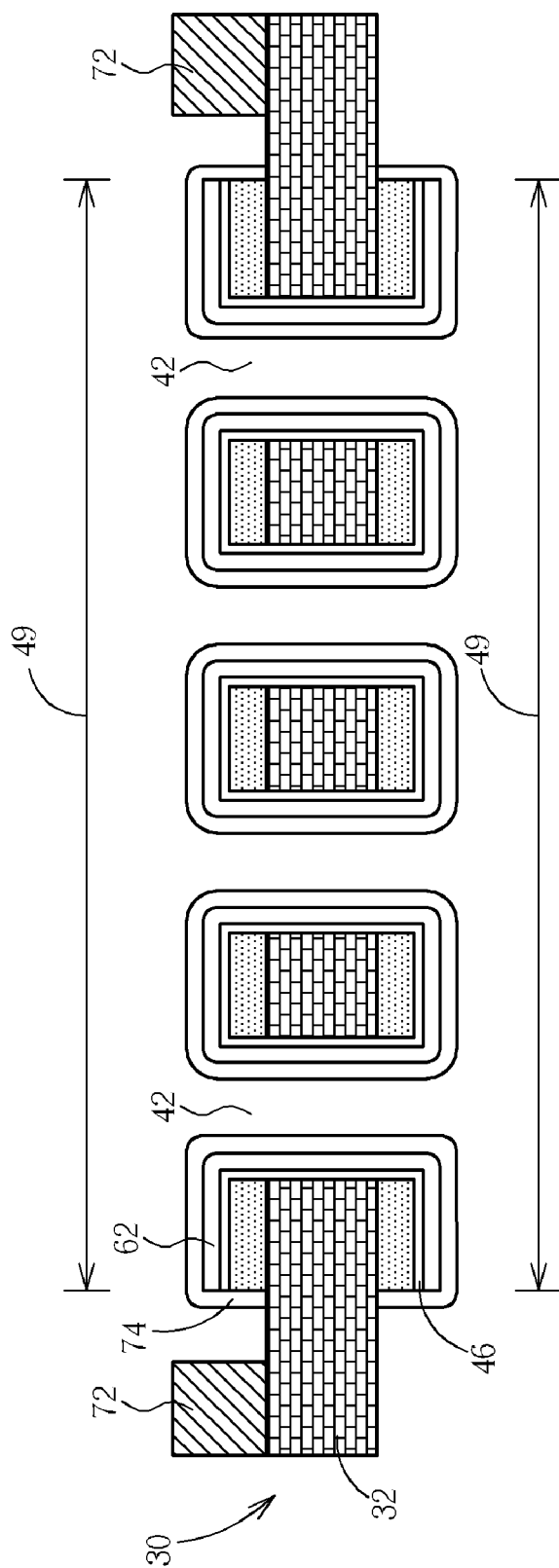

Fig. 12

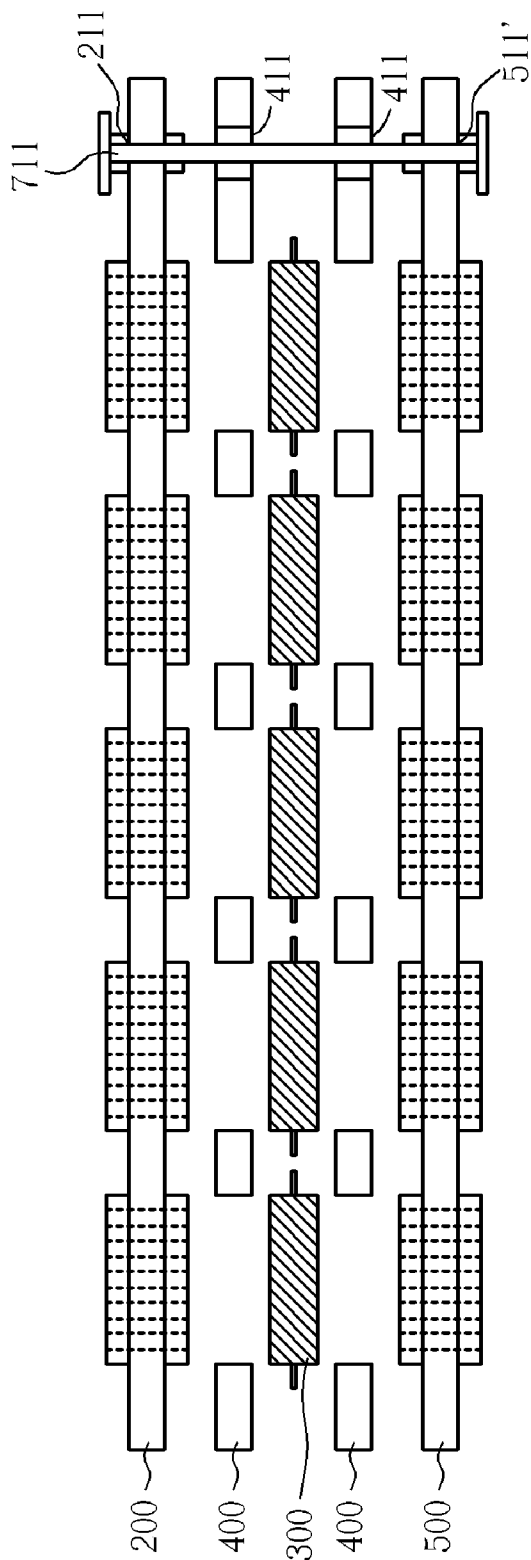

Fig. 13

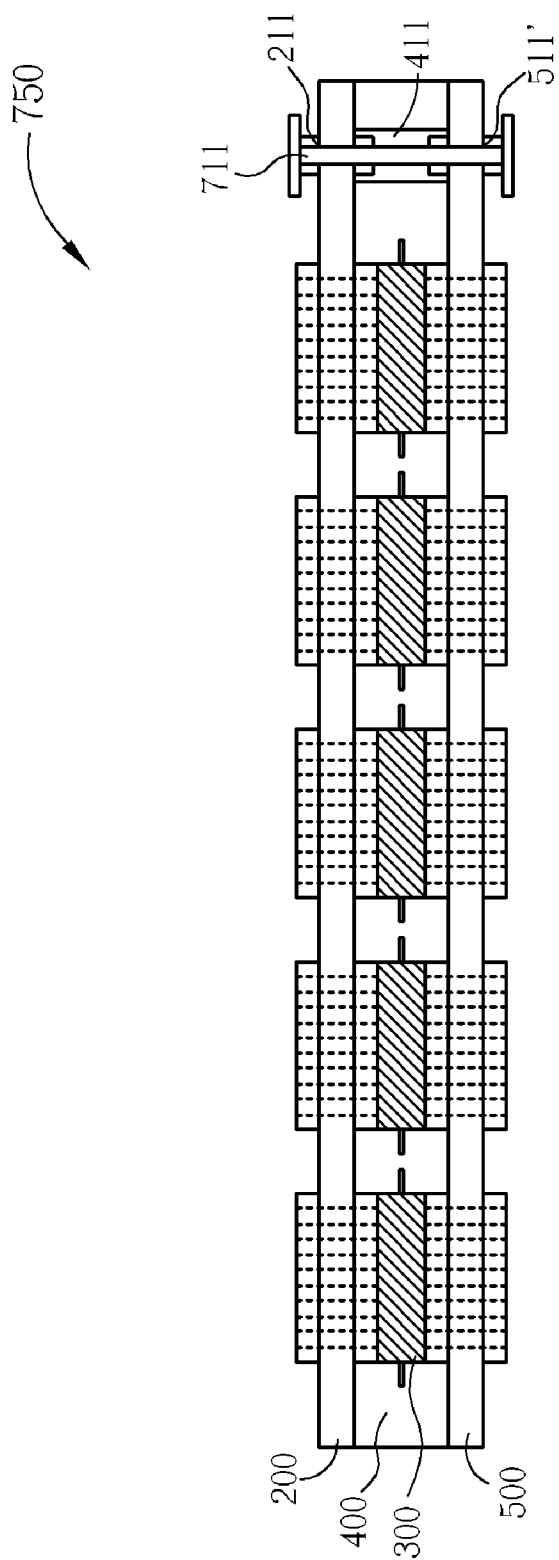

Fig. 14

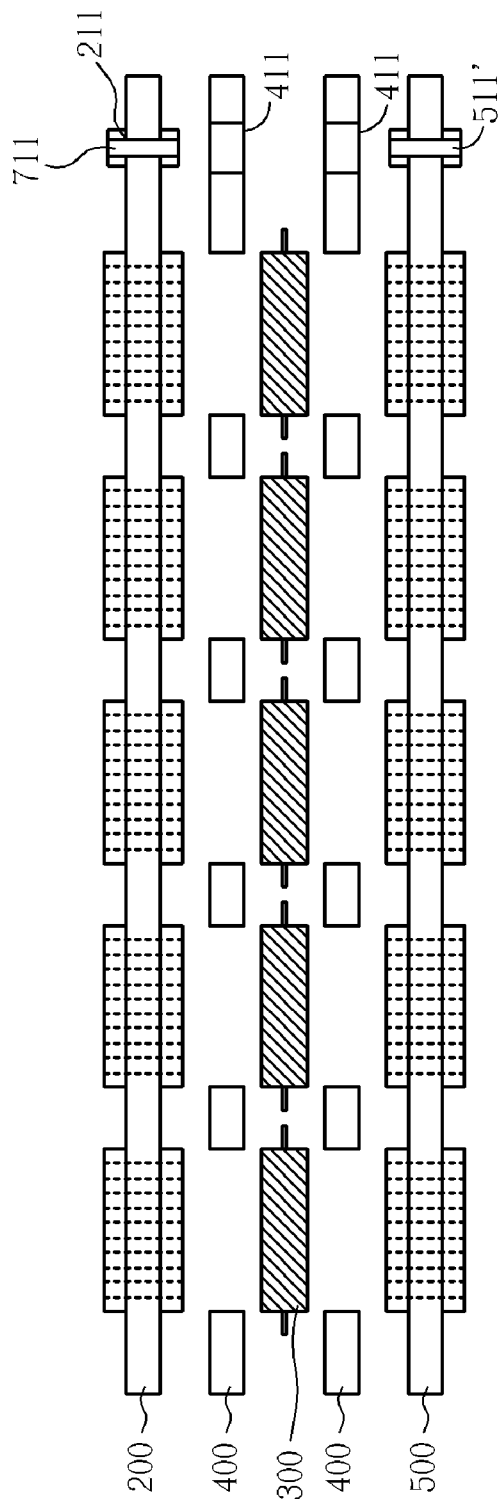

Fig. 15



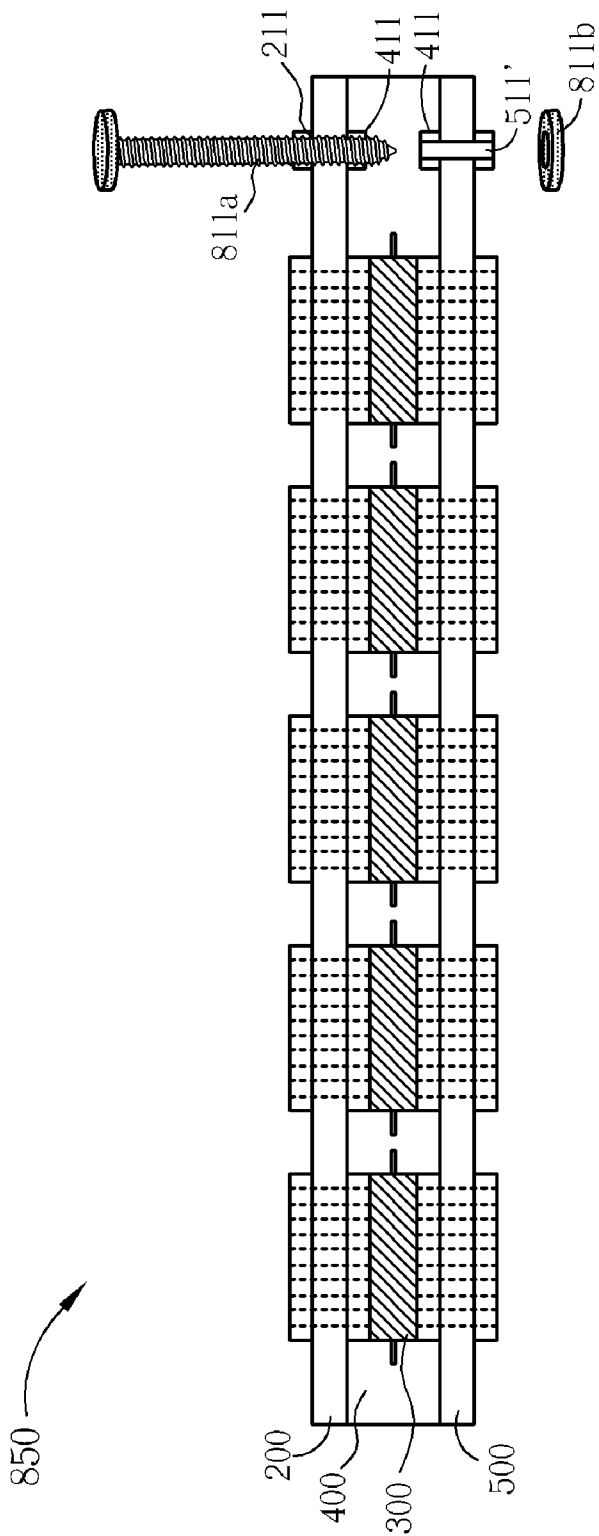

Fig. 16

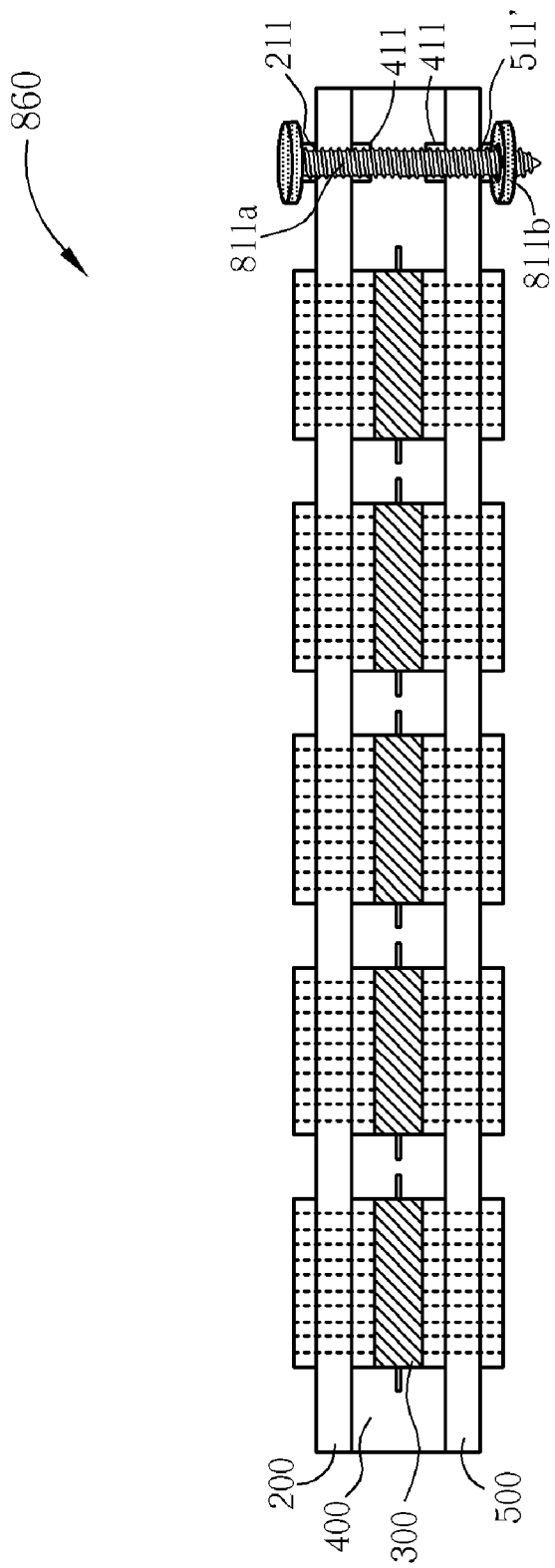

Fig. 17

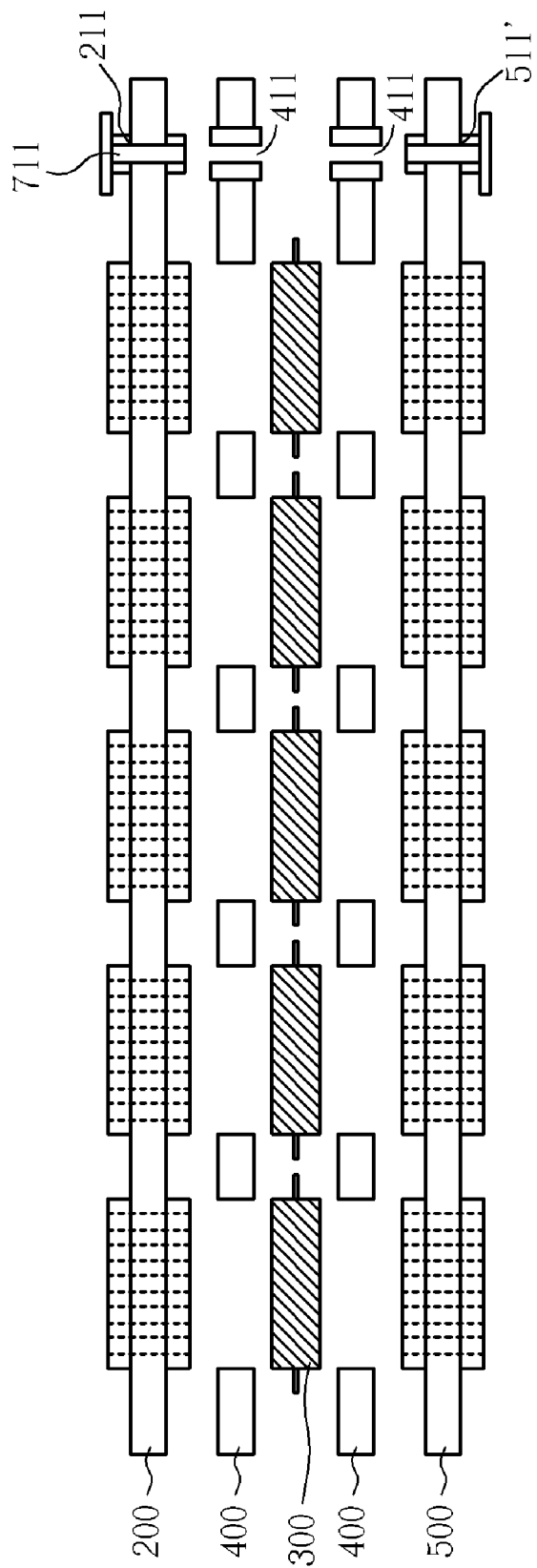

Fig. 18

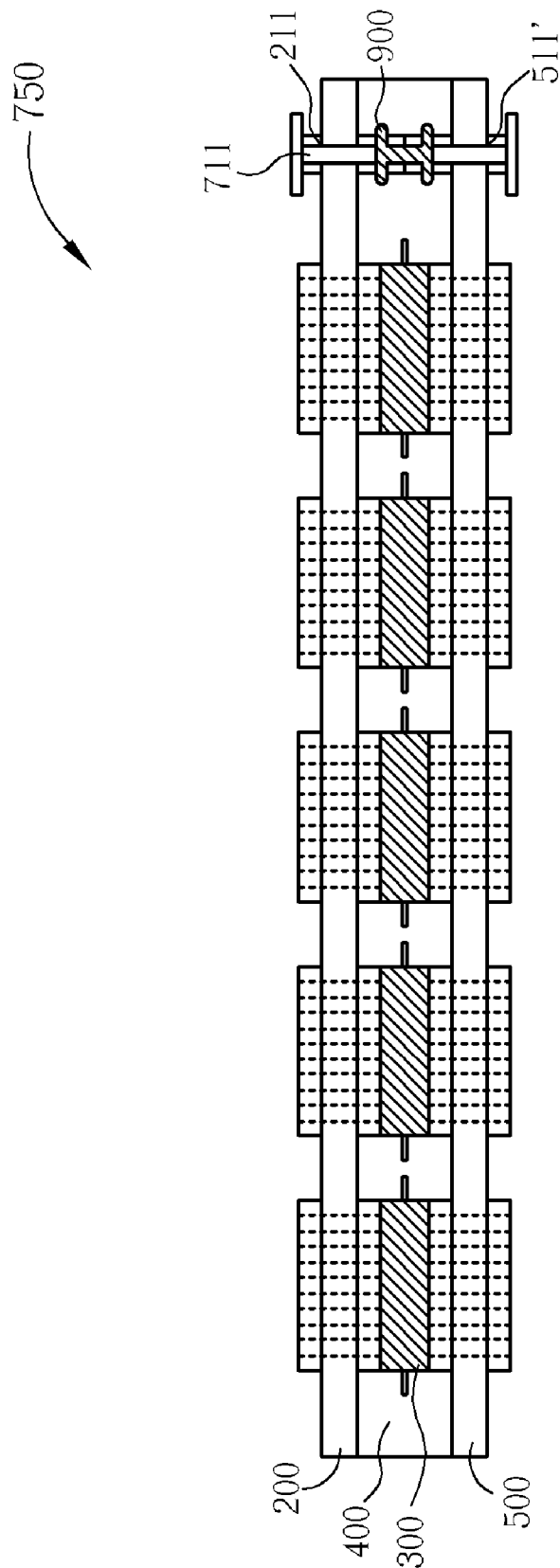

Fig. 19

## FLAT PANEL DIRECT METHANOL FUEL CELL AND METHOD FOR MAKING THE SAME

### BACKGROUND OF INVENTION

#### [0001] 1. Field of the Invention

[0002] The present invention relates generally to the field of fuel cells. More particularly, the present invention relates to a flat panel Direct Methanol Fuel Cell (DMFC) and method of making the same.

#### [0003] 2. Description of the Prior Art

[0004] A fuel cell is an electrochemical cell in which a free energy change resulting from a fuel oxidation reaction is converted into electrical energy. Fuel cells utilizing methanol as fuel are typically called Direct Methanol Fuel Cells (DMFCs), which generate electricity by combining gaseous or aqueous methanol with air. DMFC technology has become widely accepted as a viable fuel cell technology that offers itself to many application fields such as electronic apparatuses, vehicles, military equipment, the aerospace industry, and so on.

[0005] DMFCs, like ordinary batteries, provide DC electricity from two electrochemical reactions. These reactions occur at electrodes (or poles) to which reactants are continuously fed. The negative electrode (anode) is maintained by supplying methanol, whereas the positive electrode (cathode) is maintained by the supply of air. When providing current, methanol is electrochemically oxidized at the anode electrocatalyst to produce electrons, which travel through the external circuit to the cathode electrocatalyst where they are consumed together with oxygen in a reduction reaction. The circuit is maintained within the cell by the conduction of protons in the electrolyte. One molecule of methanol (CH<sub>3</sub>OH) and one molecule of water (H<sub>2</sub>O) together store six atoms of hydrogen. When fed as a mixture into a DMFC, they react to generate one molecule of CO<sub>2</sub>, 6 protons (H<sup>+</sup>), and 6 electrons to generate a flow of electric current. The protons and electrons generated by methanol and water react with oxygen to generate water. The methanol-water mixture provides an easy means of storing and transporting hydrogen, and is much better than storing liquid or gaseous hydrogen in storage tanks. Unlike hydrogen, methanol and water are liquids at room temperature and are easily stored in thin walled plastic containers. Therefore, DMFCs are lighter than their most closely related fuel cells, hydrogen-air fuel cells.

[0006] FIG. 1 and FIG. 2 illustrates a conventional DMFC 10, wherein FIG. 1 is a plan view of the conventional DMFC 10 and FIG. 2 is a cross-sectional view of the conventional DMFC 10 along line 1-1 of FIG. 1. As shown in FIG. 1 and FIG. 2, the conventional DMFC 10 comprises a bipolar platelet assembly 12 and a fuel container 14. The bipolar platelet assembly 12 comprises an upper frame 51, lower frame 52, cathode wire lath 121, a plurality of bended bipolar wire laths 122, 123, 124, 125, an anode wire lath 126, and membrane electrode assembly (MEA) 131, 132, 133, 134, 135 interposed between corresponding wire laths. The upper frame 51, the lower frame 52, the cathode wire lath 121, the plural bended bipolar wire laths 122, 123, 124, 125, the anode wire lath 126, and the MEA 131, 132, 133, 134, 135 are adhesively stacked together to produce the stack structure as shown in FIG. 2. Typically, epoxy resin 53

or the like is used in between adjacent MEA, thereby forming five basic cell units 21, 22, 23, 24 and 25. As known in the art, the cathode wire lath 121, bended bipolar wire laths 122, 123, 124, 125, and the anode wire lath 126 are titanium meshes treated by gold plating, and are therefore costly.

[0007] The basic cell unit 21 of the prior art DMFC 10 consists of the cathode wire lath 121, MEA 131, and the bended bipolar wire lath 122. The basic cell unit 22 consists of the bended bipolar wire lath 122, which functions as a cathode of the cell unit 22, MEA 132, and the bended bipolar wire lath 123, which functions as an anode of the cell unit 22. The basic cell unit 23 consists of the bended bipolar wire lath 123, which functions as a cathode of the cell unit 23, MEA 133, and the bended bipolar wire lath 124, which functions as an anode of the cell unit 23. The basic cell unit 24 consists of the bended bipolar wire lath 124, which functions as a cathode of the cell unit 24, MEA 134, and the bended bipolar wire lath 125, which functions as an anode of the cell unit 24. The basic cell unit 25 consists of the bended bipolar wire lath 125, which functions as a cathode of the cell unit 25, MEA 135, and the bended bipolar wire lath 126, which functions as an anode of the cell unit 25. Typically, each of the basic cell units 21, 22, 23, 24 and 25 provides a voltage of 0.6V, such that DMFC 10 comprising five serially connected basic cell units 21, 22, 23, 24 and 25 can provide a total voltage of 3.0V (0.6V×5=3.0V).

[0008] However, the above-described conventional DMFC 10 has several drawbacks. First, the bipolar platelet assembly 12 is too thick and thus unwieldy to carry. Furthermore, as mentioned, the cost of producing the conventional DMFC 10 is high since the cathode wire lath 121, bended bipolar wire laths 122, 123, 124, 125, and the anode wire lath 126 are titanium meshes treated by gold plating. Besides, the throughput of the conventional DMFC 10 is low because the bipolar wire laths 122, 123, 124, 125 are bended manually before mounting on the upper and lower frames. In light of the above, there is a need to provide a thin, inexpensive, and highly integrated DMFC that is capable of achieving the scale of mass production.

### SUMMARY OF INVENTION

[0009] It is therefore the primary objective of the present invention to provide an improved thin flat panel type DMFC to solve the above-mentioned problems.

[0010] It is another objective of the present invention to provide a method for fabricating a thin and highly integrated DMFC, thereby achieving the scale of mass production and thus saving cost, wherein the method for fabricating the highly integrated DMFC is compatible with standard PCB (printed circuit board) processes.

[0011] It is another objective of the present invention to provide a method for assembling a flat panel DMFC.

[0012] According to the claimed invention, a flat-panel direct methanol fuel cell (DMFC) is provided. The present invention DMFC comprises an integrated cathode electrode sheet, a membrane electrode assembly (MEA) unit, an intermediate bonding layer, an integrated anode electrode sheet, and a fuel container. The integrated cathode electrode sheet comprises a first substrate, a plurality of cathode electrode areas, a plurality of first conductive via through

holes, wherein the cathode electrode areas is electroplated on a front side and backside of the first substrate and has a plurality of apertures therein, wherein the first conductive via through holes are disposed outside the cathode electrode areas and is electrically connected to respective cathode electrode areas with a conductive wire. The membrane electrode assembly (MEA) unit comprises a plurality of proton exchange membranes corresponding to the plurality of cathode electrode areas. The intermediate bonding layer comprises at least one bonding sheet, wherein the intermediate bonding layer comprises a plurality of openings for respectively accommodating the plurality of proton exchange membranes, and a plurality of second conductive via through holes that are aligned with the first conductive via through holes. The integrated anode electrode sheet comprises a second substrate, a plurality of anode electrode areas corresponding to the plurality of cathode electrode areas, and a plurality of third conductive via through holes corresponding to the second conductive via through holes.

[0013] According to one aspect of the present invention, a method for fabricating an integrated cathode electrode sheet of a flat-panel direct methanol fuel cell is provided. The method comprises the steps of:

[0014] (1) providing a CCL (copper clad laminate) substrate comprising a base layer, a first copper layer laminated on an upper surface of the base layer, and a second copper layer laminated on a lower surface of the base layer;

[0015] (2) drilling the CCL substrate within pre-selected electrode areas to form a plurality of apertures through the first copper layer, the base layer and the second copper layer;

[0016] (3) chemically depositing a third copper layer on the CCL substrate and interior sidewalls of inside the apertures;

[0017] (4) forming a patterned resist layer on the CCL substrate to expose the pre-selected electrode areas;

[0018] (5) using the patterned resist layer as a plating mask, performing an electroplating process to electroplate a fourth copper layer within the expose the pre-selected electrode areas and area not covered by the patterned resist layer, and then electroplating a Sn/Pb layer on the fourth copper layer;

[0019] (6) stripping the patterned resist layer;

[0020] (7) performing a copper etching process to etch away the third copper layer and the first and second copper layer that are not covered by the Sn/Pb layer; and

[0021] (8) removing the Sn/Pb layer to expose the fourth copper layer.

[0022] In addition, the present invention discloses a method for assembling flat panel direct methanol fuel cells, the method comprising: providing an integrated cathode electrode plate comprising a first substrate, a plurality of cathode electrode areas, and a first conductive via through hole, wherein the cathode electrode areas are electroplated on both the front and the backside of the first substrate and have a plurality of apertures therein, wherein the first conductive via through hole is disposed outside the cathode

electrode areas and is electronically connected to the respective cathode electrode areas with a conductive wire; providing a plurality of proton exchange membranes corresponding to the plurality of cathode electrode areas; providing an intermediate bonding layer comprising at least one bonding sheet, wherein the intermediate bonding layer comprises a plurality of openings for respectively accommodating the plurality of proton exchange membranes, and a second conductive via through hole that is aligned with the first conductive via through hole; providing an integrated anode electrode plate comprising a second substrate, a plurality of anode electrode areas corresponding to the plurality of cathode electrode areas, and a third conductive via through hole corresponding to the first conductive via through hole; stacking the integrated cathode electrode plate, the plurality of proton exchange membranes, the intermediate bonding layer, and the integrate anode electrode plate in order; aligning and penetrating the first conductive via through hole, the second conductive via through hole, and the third conductive via through hole by using a metal plug; utilizing the metal plug to conduct and to fix the first conductive via through hole, the second conductive via through hole, and the third conductive via through hole in place for forming a bipolar/MEA assembly; and combining the bipolar/MEA assembly with a fuel container.

[0023] These and other objectives of the present invention will no doubt become obvious to those of ordinary skill in the art after reading the following detailed description of the preferred embodiment that is illustrated in the various figures and drawings.

#### BRIEF DESCRIPTION OF DRAWINGS

[0024] FIG. 1 is a plain view of the conventional Direct Methanol Fuel Cell.

[0025] FIG. 2 is a cross-sectional view of the conventional Direct Methanol Fuel Cell along line 1-1 of FIG. 1.

[0026] FIG. 3 is a perspective, exploded diagram illustrating a flat panel Direct Methanol Fuel Cell with five serially connected basic cell units in accordance with one preferred embodiment of the present invention.

[0027] FIG. 4 to FIG. 12 illustrate a method for fabricating integrated thin cathode electrode sheet and integrated thin anode electrode sheet of the DMFC according to this invention.

[0028] FIG. 13 and FIG. 14 are side-view diagrams showing the means by which the integrated thin cathode electrode sheet, the MEA unit, the intermediate bonding layer, and the integrated thin anode electrode sheet are assembled according to another embodiment of the present invention.

[0029] FIG. 15 to FIG. 17 are side-view diagrams showing the means by which the integrated thin cathode electrode sheet, the MEA unit, the intermediate bonding layer, and the integrated thin anode electrode sheet are assembled according to another embodiment of the present invention.

[0030] FIG. 18 is a perspective diagram showing a stage before the integrated thin cathode electrode sheet, the MEA unit, the intermediate bonding layer, and the integrated thin anode electrode sheet are laminated.

[0031] FIG. 19 is a perspective diagram showing a stage after the integrated thin cathode electrode sheet, the MEA unit, the intermediate bonding layer, and the integrated thin anode electrode sheet are laminated.

#### DETAILED DESCRIPTION

[0032] Please refer to FIG. 3. FIG. 3 is a perspective, exploded diagram illustrating a flat panel DMFC 20 with five serially connected basic cell units in accordance with one preferred embodiment of the present invention. It is to be understood that the flat panel DMFC 20 with five serially connected basic cell units is merely an exemplary embodiment. Depending on the requirements of the applied apparatuses, other numbers of basic cell units such as ten or twenty may be used. As shown in FIG. 3, the present invention flat panel DMFC 20 generally comprises an integrated thin cathode electrode sheet 200, Membrane Electrode Assembly (MEA) unit 300, intermediate bonding layer 400, integrated thin anode electrode sheet 500, and a fuel container 600.

[0033] The integrated thin cathode electrode sheet 200 comprises a substrate 210, cathode electrode areas 201, 202, 203, 204, and 205, and conductive via through holes 211, 212, 213, 214, and 215. Preferably, on the surface area of the substrate 210 outside the cathode electrode areas 201, 202, 203, 204, and 205, and the conductive via through hole 211, 212, 213, 214, and 215, a layer of solder resist is coated thereon. At the corners of the substrate 210, mounting through holes 221, 222, 223, and 224 are provided. It is noteworthy that the integrated thin cathode electrode sheet 200 is fabricated by using PCB compatible processes. The substrate 210 may be made of ANSI-grade glass fiber reinforced polymeric materials such as FR-1, FR-2, FR-3, FR-4, FR-5, CEM-1 or CEM-3, but not limited thereto. Each of the cathode electrode areas 201, 202, 203, 204, and 205, on which a plurality of through holes are formed, is defined by a patterned copper foil. The opening ratio of each of the cathode electrode areas 201, 202, 203, 204, and 205, which is the ratio of the surface area of the through holes to the area of each of the cathode electrode areas, is preferably no less than 50%.

[0034] The conductive via through hole 212 is electrically connected to the cathode electrode area 201 with the conductive wire 250. The conductive via through hole 213 is electrically connected to the cathode electrode area 202 with the conductive wire 251. The conductive via through hole 214 is electrically connected to the cathode electrode area 203 with the conductive wire 252. The conductive via through hole 215 is electrically connected to the cathode electrode area 204 with the conductive wire 253. The cathode electrode area 205 is electrically connected to a positive (cathode) electrode node 261, which, in operation, is further electrically connected with an external circuit by conductive wire 254. The conductive via through hole 211, which acts as a negative (anode) electrode node of the DMFC 20, is electrically connected with the external circuit and positive (cathode) electrode node 261 in operation.

[0035] The MEA unit 300 comprises a first proton exchange membrane 301, a second proton exchange membrane 302, a third proton exchange membrane 303, a fourth proton exchange membrane 304, and a fifth proton exchange membrane 305, corresponding to the cathode electrode areas

201, 202, 203, 204, and 205. Each of the proton exchange membranes 301, 302, 303, 304, and 305 may use commercially available proton conducting polymer electrolyte membranes, for example, Nafion™, but not limited thereto.

[0036] The intermediate bonding layer 400 comprises at least one bonding sheet, which may be made of Prepreg B-stage resin, which is an ordinary material in PCB processes. The Prepreg B-stage resin may be completely cured at about 140° C. for process time period of about 30 minutes. Corresponding to the proton exchange membranes 301, 302, 303, 304, and 305, five openings 401, 402, 403, 404, and 405 are provided on the intermediate bonding layer 400 for fitly accommodating respective proton exchange membranes. At a side of the opening 401 corresponding to the conductive via through hole 211 of the substrate 210, as specifically indicated in FIG. 3, a conductive via through hole 411 is provided. At a side of respective openings 402, 403, 404, and 405 corresponding to the conductive via through holes 212, 213, 214, and 215, conductive via through holes 412, 413, 414, and 415 are provided. In another case, the intermediate bonding layer 400 may further a thin supporting layer that is made of glass fiber reinforced polymeric materials such as FR-1, FR-2, FR-3, FR-4, FR-5, CEM-1 or CEM-3. At the corners, corresponding to the mounting through holes 221, 222, 223, and 224 of the substrate 210, there are mounting through holes 421, 422, 423, and 424 provided.

[0037] The integrated thin anode electrode sheet 500 comprises a substrate 510, anode electrode areas 501, 502, 503, 504, and 505, and conductive pads 511, 512, 513, 514, and 515. It is noteworthy that the anode electrode areas 501, 502, 503, 504, 505 are defined simultaneously with the conductive pads 511, 512, 513, 514, 515. At the corners of the substrate 510, corresponding to the mounting through holes 221, 222, 223, and 224 of the substrate 210, there are mounting through holes 521, 522, 523, and 524 provided. The integrated thin anode electrode sheet 500 is fabricated by using PCB compatible processes. Likewise, the substrate 510 may be made of ANSI-grade glass fiber reinforced polymeric materials such as FR-1, FR-2, FR-3, FR-4, FR-5, CEM-1, CEM-3 or the like. Each of the anode electrode areas 501, 502, 503, 504, and 505, on which a plurality of through holes are formed, is defined by a patterned copper foil. The opening ratio of each of the anode electrode areas is preferably no less than 50%.

[0038] The fuel container 600 has fuel channel 601 and mounting through holes 621, 622, 623, and 624 corresponding to the mounting through holes 221, 222, 223, and 224 of the substrate 210. The fuel container 600 may be made of polymeric materials such as epoxy resin, polyimide, or Acrylic. The fuel channel 601 may be fabricated by using conventional mechanical grinding methods or plastic extrusion methods.

[0039] When assembling, the proton exchange membranes 301, 302, 303, 304, and 305 are fitly installed within the openings 401, 402, 403, 404, and 405 of the intermediate bonding layer 400. The intermediate bonding layer 400, together with the installed proton exchange membranes 301, 302, 303, 304, and 305, is then sandwiched by the integrated thin cathode electrode sheet 200 and the integrated thin anode electrode sheet 500. The resultant laminate stack consisting in the order of the integrated thin cathode electrode sheet 200, intermediate bonding layer 400 (and

installed MEA unit **300**), and the integrated thin anode electrode sheet **500** is then mounted on the fuel container **600**.

[0040] The conductive via through holes **211**, **212**, **213**, **214** and **215** of the integrated thin cathode electrode sheet **200** are aligned, and in contact, with the respective conductive via through holes **411**, **412**, **413**, **414** and **415** of the intermediate bonding layer **400**, which are aligned with the conductive pads **511**, **512**, **513**, **514** and **515** of the integrated thin anode electrode sheet **500**. Conventional soldering process may be used to electrically connected and fix the aligned conductive through holes such as conductive via through holes **211**, **411**, and conductive pad **511**, and so on. By doing this, the cathode electrode area **201** of the integrated thin cathode electrode sheet **200** is electrically connected to the anode electrode area **502** of the integrated thin anode electrode sheet **500** through the conductive path constituted by the conductive wire **250**, the soldered conductive via through holes **212** and **412**, and the conductive pad **512** of the integrated thin anode electrode sheet **500**. The cathode electrode area **202** of the integrated thin cathode electrode sheet **200** is electrically connected to the anode electrode area **503** of the integrated thin anode electrode sheet **500** through the conductive path constituted by the conductive wire **251**, the soldered conductive via through holes **213** and **413**, and the conductive pad **513** of the integrated thin anode electrode sheet **500**, and so on. The conductive via through hole **211** of the integrated thin cathode electrode sheet **200**, which acts as the negative electrode of the DMFC **20**, is electrically connected to the anode electrode area **501** of the integrated thin anode electrode sheet **500** through the conductive via through hole **411** of the intermediate bonding layer **400**.

[0041] It is advantageous to use the present invention because the DMFC **20** has integrated thin cathode electrode sheet **200** and integrated thin anode electrode sheet **500**, which reduce the thickness as well as the production cost of the DMFC **20**. No bended bipolar wire lath is needed. The integrated thin cathode electrode sheet **200** and integrated thin anode electrode sheet **500** are fabricated by using PCB compatible processes, thus can achieve the scale of mass production. Another benefit is that the control circuit layout for controlling the DMFC and external circuit can be integrated on the substrate **210** or **510**.

[0042] A method for fabricating integrated thin cathode electrode sheet **200** and integrated thin anode electrode sheet **500** of the DMFC **20** is now described in detail with reference to FIG. 4 to FIG. 12. According to this invention, the method for fabricating integrated thin cathode electrode sheet **200** and integrated thin anode electrode sheet **500** of the DMFC **20** is compatible with standard PCB processes.

[0043] First, as shown in FIG. 4, a CCL (Copper Clad Laminate) substrate **30** is provided. The CCL substrate **30** is commercially available and has a thickness of few millimeters. The CCL substrate **30** comprises a base layer **32**, a copper layer **34** laminated on an upper surface of the base layer **32**, and a copper layer **36** laminated on a lower surface of the base layer **32**.

[0044] As shown in FIG. 5, a conventional drilling process is carried out to drill a plurality of through holes **42** in the CCL substrate **30** within pre-selected electrode areas (not explicitly shown). In accordance with the preferred embodi-

ment, the surface area of the through holes **42** within a pre-selected electrode area is preferably more than 50% of the surface area of the pre-selected electrode area.

[0045] Subsequently, as shown in FIG. 6, a thin copper layer **46** is chemically deposited on the CCL substrate **30** and on the exposed interior sidewalls of the through holes **42**. It is noted that the copper layer **46** is deposited in a non-selective manner.

[0046] As shown in FIG. 7, a patterned resist (dry film) **48** is formed on the CCL substrate **30** to define the electrode area **49**. Taking the integrated cathode electrode sheet **200** of FIG. 3 as an example, the electrode area **49** defined by the patterned resist **48** is one of the cathode electrode areas **201~205**. Not shown in FIG. 7, the patterned resist **48** also defines the conductive wires **250~254** and the positive electrode node **261**. It is noted that the conductive via through holes **211~215** of the integrated cathode electrode sheet **200** are formed simultaneously with the through holes **42** in the same drilling process. Taking the integrated anode electrode sheet **500** of FIG. 3 as an example, the electrode area **49** defined by the patterned resist **48** is one of the anode electrode areas **501~505**, and the patterned resist **48** also defines the conductive pads **511~515** (not shown in FIG. 7).

[0047] As shown in FIG. 8, using the patterned resist **48** as a plating mask, an electroplating process is carried out to form a copper layer **62** on the CCL substrate **30** where is not covered by the patterned resist **48** including the electrode area **49**. A tin/lead (Sn/Pb) composite layer **64** is then electroplated on the copper layer **62**.

[0048] As shown in FIG. 9, the patterned resist **48** is stripped to expose the rest of the copper layer **46**.

[0049] As shown in FIG. 10, a copper etching process such as conventional wet etching is then carried out to etch away the copper layer **46** and the copper layers **34** and **36** that are not covered by the Sn/Pb layer **64**. After this, another etching process is carried out to etch away the Sn/Pb layer **64**, thereby exposing the remaining copper layer **62**. At this stage, the fabrication of the integrated anode electrode sheet **500** of FIG. 3 is complete.

[0050] To complete the fabrication of the integrated cathode electrode sheet **200** of FIG. 3, there are still few steps to go. As shown in FIG. 11, to prevent short-circuiting caused during the subsequent soldering process and potential damages to the substrate, a solder resist layer **72** is coated. The solder resist layer **72** may be made of materials that are commercially available and are commonly used in conventional PCB processes. Preferably, the solder resist layer **72** is made of photosensitive materials that can be patterned by using conventional lithographic process to define the protected area on the electrode sheet **200**.

[0051] As shown in FIG. 12, optionally, to further protect the integrated cathode electrode sheet **200** from oxidation due to long-term contact with air, a conductive protection layer **74** is coated on the electrode. The conductive protection layer **74** may be made of nickel/gold (Ni/Au), tin/lead (Sn/Pb), or chemical silver.

[0052] Nevertheless, the assembly of the integrated thin cathode electrode sheet **200**, the MEA unit **300**, the intermediate bonding layer **400**, and the integrated thin anode electrode sheet **500** still has a significant disadvantage.



Please refer to **FIG. 18** and **FIG. 19**. **FIG. 18** is a perspective diagram showing a stage before the integrated thin cathode electrode sheet **200**, the MEA unit **300**, the intermediate bonding layer **400**, and the integrated thin anode electrode sheet **500** are laminated whereas **FIG. 19** is a diagram showing a stage after the integrated thin cathode electrode sheet **200**, the MEA unit **300**, the intermediate bonding layer **400**, and the integrated thin anode electrode sheet **500** are laminated. As shown in **FIG. 19**, the excess resin **900** that is compressed during the laminating process will overflow and plug the conductive via holes **411** and eventually cause a circuit disconnection between the anode and cathode.

[0053] Please refer to **FIG. 13** and **FIG. 14**. **FIG. 13** and **FIG. 14** are side-view diagrams showing the means by which the integrated thin cathode electrode sheet **200**, the MEA unit **300**, the intermediate bonding layer **400**, and the integrated thin anode electrode sheet **500** are assembled according to another embodiment of the present invention. At first, the conductive pads **511-515** are fabricated into the conductive via through holes **511'-515'**. As shown in **FIG. 13**, a metal plug, such as a rivet **711**, is then used for aligning and penetrating through the conductive via through hole **211** of the integrated thin cathode electrode sheet **200**, the conductive via through hole **411** of the intermediate bonding layer **400**, and the conductive via through hole **511'** of the integrated thin anode electrode sheet **500**. Next, the integrated thin cathode electrode sheet **200**, the MEA unit **300**, the intermediate bonding layer **400**, and the integrated thin anode electrode sheet **500** are laminated together for forming a bipolar/MEA assembly **750**, which can further be fabricated into a fuel cell with a fuel base (not shown). According to the present invention, the rivet **711** used for conducting the integrated cathode electrode sheet **200** can be comprised of conductive materials such as aluminum, tin, or copper-zinc alloy.

[0054] Please refer to **FIG. 15** to **FIG. 17**. **FIG. 15** to **FIG. 17** are side-view diagrams showing the means by which the integrated thin cathode electrode sheet **200**, the MEA unit **300**, the intermediate bonding layer **400**, and the integrated thin anode electrode sheet **500** are assembled according to another embodiment of the present invention. At first, the conductive pads **511-515** are fabricated into the conductive via through holes **511'-515'**. As shown in **FIG. 15**, the integrated thin cathode electrode sheet **200**, the MEA unit **300**, the intermediate bonding layer **400**, and the integrated thin anode electrode sheet **500** are aligned and laminated together for forming a bipolar/MEA assembly **850**, as shown in **FIG. 16**. Since the resin utilized during the lamination process can easily plug the conductive via through holes, a screw **811a** and a screw nut **811b** are used as metal plugs for penetrating the plugged conductive via through holes and facilitating the conductivity of the bipolar/MEA assembly **860**.

[0055] To sum up, the present invention flat panel type DMFC encompasses at least the following advantages.

[0056] (1) The cost per cell is reduced since the starting material, CCL substrate, is cheaper. Besides, the process of fabricating the germane parts, the integrated thin cathode electrode sheet **200** and integrated thin anode electrode sheet **500** of the DMFC **20**, is compatible with mature PCB processes.

[0057] (2) The process of fabricating the germane parts, the integrated thin cathode electrode sheet **200** and integrated thin anode electrode sheet **500** of the DMFC **20**, is compatible with mature PCB process. The production cost is therefore reduced.

[0058] (3) No bended bipolar wire lath is needed. The manufacture of the integrated thin cathode electrode sheet **200** and integrated thin anode electrode sheet **500** can therefore achieve the scale of mass production. Direct stack assembly is more precise.

[0059] (4) The control circuit layout for controlling the lithium battery of portable apparatus, the DMFC and the external circuit can be simultaneously fabricated on the laminate substrate, thus reducing the size of the DMFC and increasing the integrity of the DMFC.

[0060] Those skilled in the art will readily observe that numerous modifications and alterations of the device and method may be made while retaining the teachings of the invention. Accordingly, the above disclosure should be construed as limited only by the metes and bounds of the appended claims.

What is claimed is:

1. A method for assembling a flat panel direct methanol fuel cell, the method comprising:

providing an integrated cathode electrode sheet comprising a first substrate, a plurality of cathode electrode areas, and a first conductive via through hole, wherein the cathode electrode areas are electroplated on both the front and the backside of the first substrate and have a plurality of apertures therein, wherein the first conductive via through hole is disposed outside the cathode electrode areas and is electronically connected to the respective cathode electrode areas with a conductive wire;

providing a plurality of proton exchange membranes corresponding to the plurality of cathode electrode areas;

providing an intermediate bonding layer comprising at least one bonding sheet, wherein the intermediate bonding layer comprises a plurality of openings for respectively accommodating the plurality of proton exchange membranes, and a second conductive via through hole that is aligned with the first conductive via through hole;

providing an integrated anode electrode sheet comprising a second substrate, a plurality of anode electrode areas corresponding to the plurality of cathode electrode areas, and a third conductive via through hole corresponding to the first conductive via through hole;

stacking the integrated cathode electrode sheet, the plurality of proton exchange membranes, the intermediate bonding layer, and the integrate anode electrode sheet in order;

aligning and penetrating the first conductive via through hole, the second conductive via through hole, and the third conductive via through hole by using a metal plug;

utilizing the metal plug to conduct and to fix the first conductive via through hole, the second conductive via

through hole, and the third conductive via through hole in place for forming a bipolar/MEA assembly; and

combining the bipolar/MEA assembly with a fuel container.

2. The method of claim 1, wherein the cathode electrode area comprises a copper clad base layer, a chemically deposited copper layer on the copper clad base layer, an electroplated copper layer formed on the chemically deposited copper layer, and a conductive protection layer on the electroplated copper layer.

3. The method of claim 2, wherein the conductive protection layer comprises Ni/Au.

4. The method of claim 1, wherein the proton exchange membrane is a solid-state proton exchange membrane.

5. The method of claim 1, wherein bonding sheet is comprised of "Prepreg" B-stage resin.

6. The method of claim 1, wherein the first substrate is comprised of glass fiber reinforced polymeric materials.

7. The method of claim 6, wherein the glass fiber reinforced polymeric materials comprise ANSI-grade FR-1, FR-2, FR-3, FR-4, FR-5, CEM-1, or CEM-3.

8. The method of claim 1, wherein the metal plug is a rivet.

9. The method of claim 1, wherein the metal plug is a screw.

10. A flat panel direct methanol fuel cell (DMFC) comprising:

an integrated cathode electrode sheet comprising a first substrate, a plurality of cathode electrode areas, a first conductive via through hole, wherein the cathode electrode areas are electroplated on both the front and the backside of the first substrate and have a plurality of apertures therein, wherein the first conductive via through hole is disposed outside the cathode electrode areas and is electronically connected to the respective cathode electrode areas with a conductive wire;

a plurality of proton exchange membranes corresponding to the plurality of cathode electrode areas;

an intermediate bonding layer comprising at least one bonding sheet, wherein the intermediate bonding layer comprises a plurality of openings for respectively accommodating the plurality of proton exchange membranes, and a second conductive via through hole that is aligned with the first conductive via through hole;

an integrated anode electrode sheet comprising a second substrate, a plurality of anode electrode areas disposed corresponding to the plurality of cathode electrode areas, and a third conductive via through hole corresponding to the first conductive via through hole, wherein the integrated cathode electrode sheet, the plurality of proton exchange membranes, the intermediate bonding layer, and the integrated anode electrode sheet are stacked in order;

a metal plug aligning and conducting the first conductive via through hole, the second conductive via through hole, and the third conductive via through hole; and a fuel container.

11. The flat panel direct methanol fuel cell of claim 10, wherein the cathode electrode area comprises a copper clad base layer, a chemically deposited copper layer on the copper clad base layer, an electroplated copper layer formed on the chemically deposited copper layer, and a conductive protection layer on the electroplated copper layer.

12. The flat panel direct methanol fuel cell of claim 11, wherein the conductive protection layer comprises Ni/Au.

13. The flat panel direct methanol fuel cell of claim 10, wherein the proton exchange membrane is a solid-state proton exchange membrane.

14. The flat panel direct methanol fuel cell of claim 10, wherein bonding sheet is comprised of Prepreg B-stage resin.

15. The flat panel direct methanol fuel cell of claim 10, wherein the metal plug is a rivet.

16. The flat panel direct methanol fuel cell of claim 10, wherein the metal plug is a screw.

\* \* \* \* \*