



US00D430525S

United States Patent [19]
Lampkin

[11] **Patent Number: Des. 430,525**
[45] **Date of Patent: ** Sep. 5, 2000**

[54] **FRONT FACE OF A VEHICLE WHEEL**
[75] Inventor: **Ivanov Lampkin**, Munich, Germany
[73] Assignee: **Bayerische Motoren Werke Aktiengesellschaft**, Munich, Germany
[**] Term: **14 Years**

D. 398,896	9/1998	Suprihanto	D12/209
D. 408,774	4/1999	Nishida	D12/209
D. 412,148	7/1999	Fitzgerald	D12/209
D. 412,149	7/1999	Corioni	D12/211
D. 416,845	11/1999	Frueh	D12/209
D. 416,846	11/1999	Melegari et al.	D12/209

[21] Appl. No.: **29/097,530**
[22] Filed: **Dec. 9, 1998**
[30] **Foreign Application Priority Data**
Jun. 10, 1998 [DE] Germany 980 08 185
[51] **LOC (7) Cl.** **12-16**
[52] **U.S. Cl.** **D12/211**
[58] **Field of Search** D12/204-211;
303/37.1, 64.1, 65

OTHER PUBLICATIONS

Custom Wheel & Tire Style Guide, p. 17, See "AC Schnitzer 1-PC Wheel", 1994

Primary Examiner—Stacia Cadmus
Attorney, Agent, or Firm—Evenson, McKeown, Edwards & Lenahan, P.L.L.C.

[57] **CLAIM**

The ornamental design for a front face of a vehicle wheel, as shown and described.

DESCRIPTION

FIG. 1 is a front view of a front face of a vehicle wheel according to my novel design; and, FIG. 2 is a perspective view from the front side of a front face of a vehicle wheel according to my novel design. The dash line included depicts environment and is not part of the claimed design.

[56] **References Cited**
U.S. PATENT DOCUMENTS
D. 302,264 7/1989 Soederberg D12/209
D. 350,523 9/1994 Mobius D12/209
D. 367,030 2/1996 Bouldoukian D12/209
D. 368,884 4/1996 Cole D12/209
D. 383,722 9/1997 Sgalia et al. D12/209

1 Claim, 1 Drawing Sheet

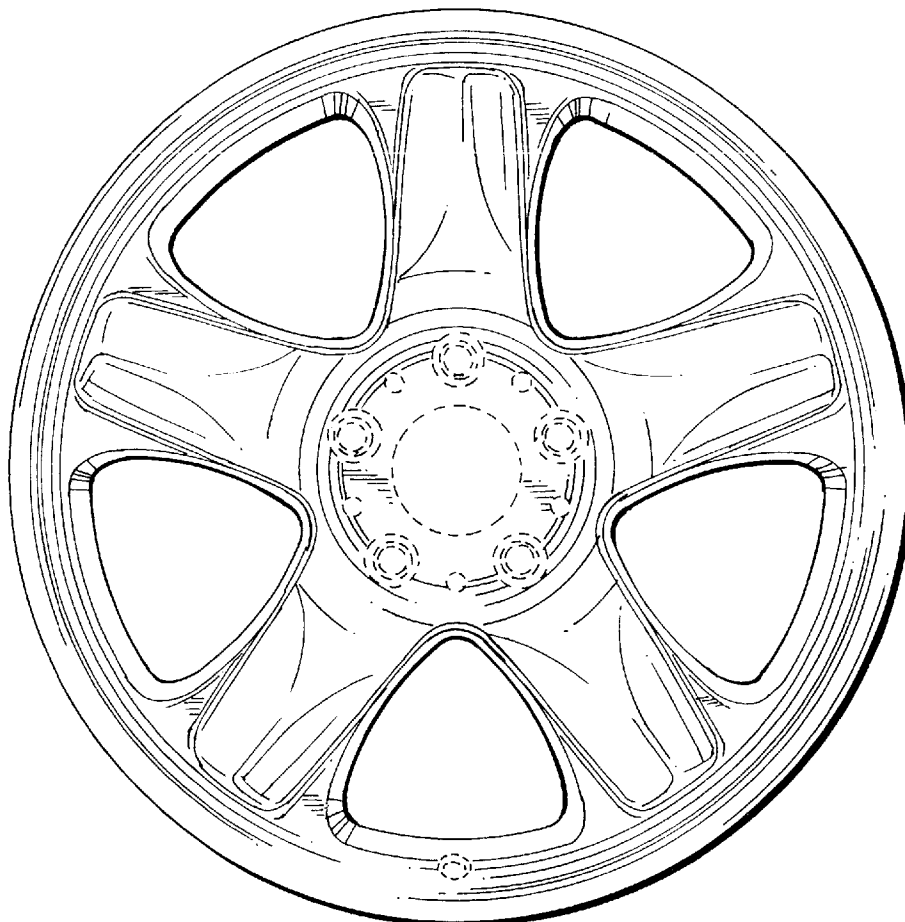

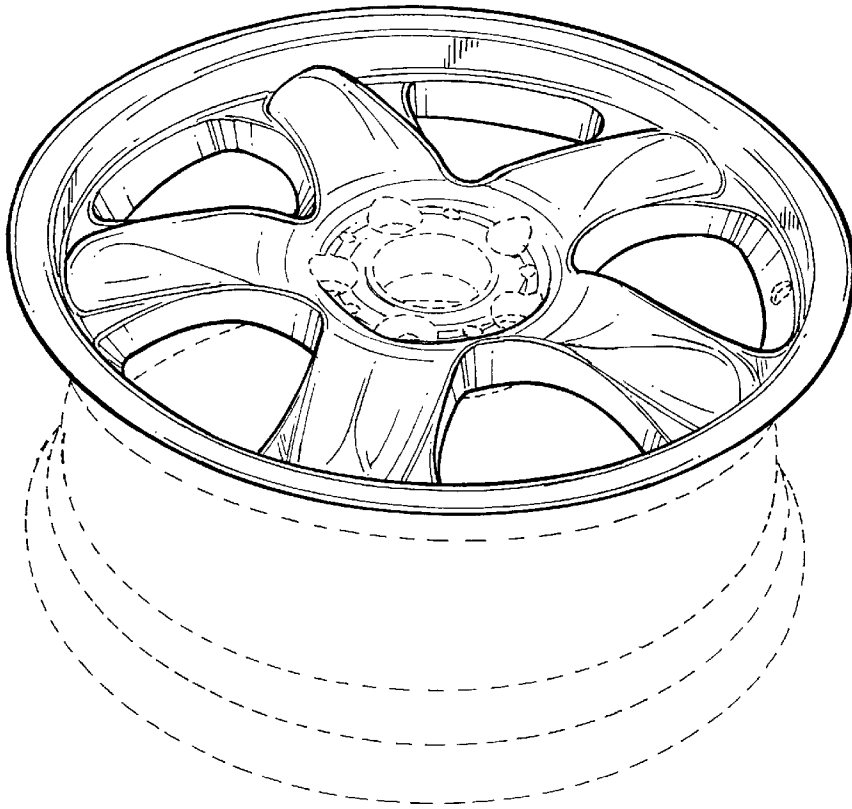

FIG. 2

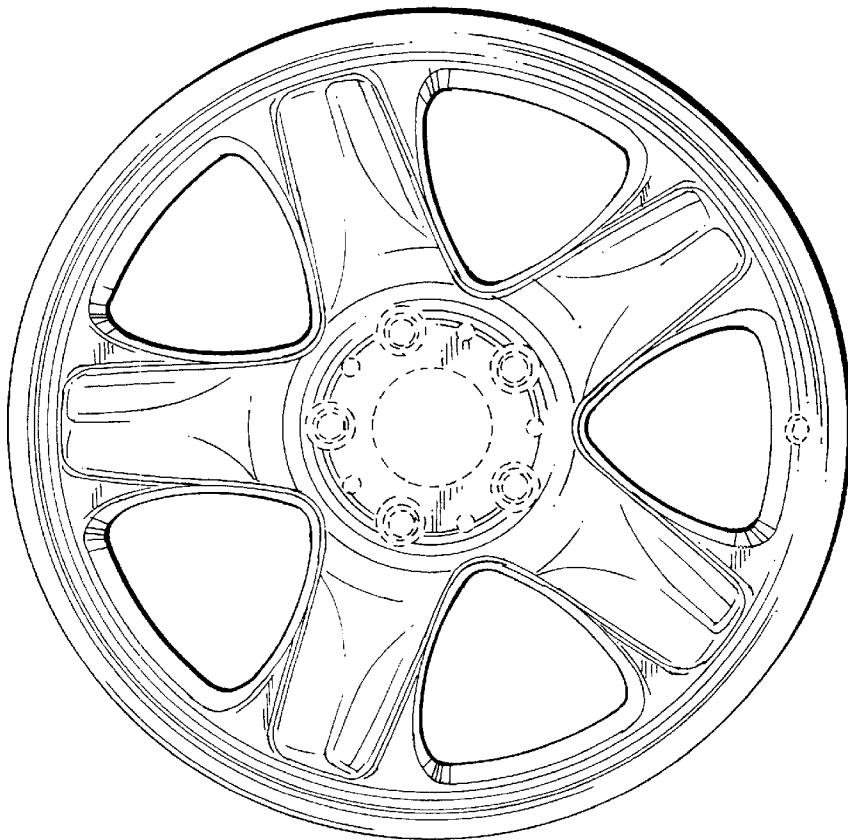

FIG. 1