

No. 626,085.

Patented May 30, 1899.

J. ORMEROD.
SYRUP JAR.

(Application filed Mar. 7, 1899.)

(No Model.)

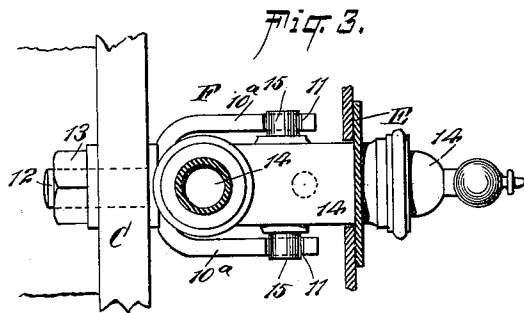
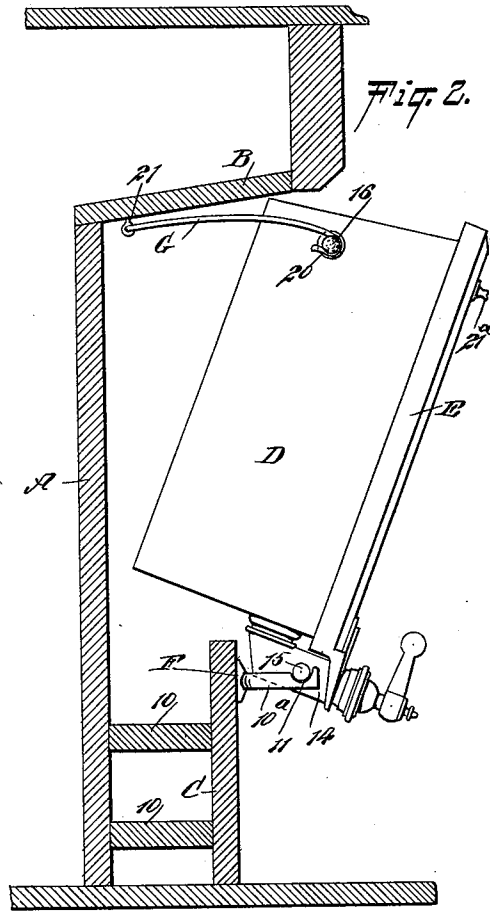
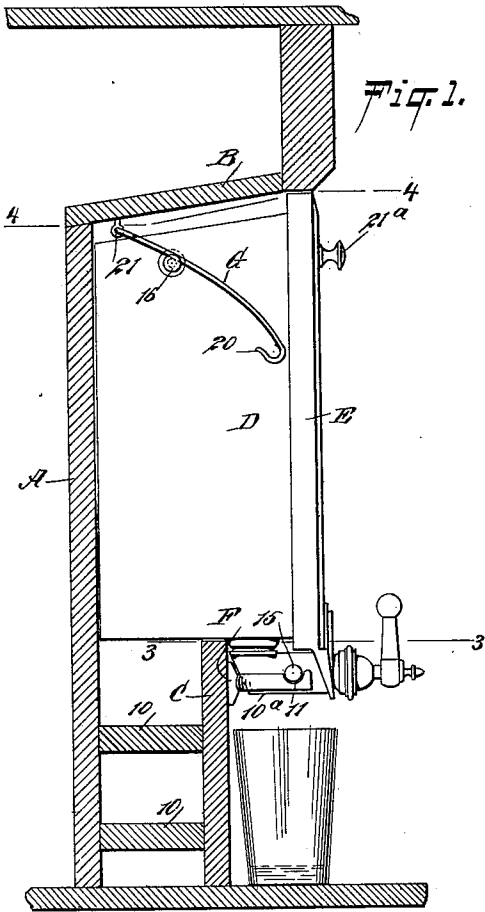

WITNESSES:

William P. Goebel,
John P. ...

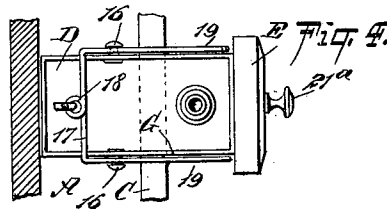

INVENTOR
John Ormerod.
BY *...*
ATTORNEYS.

UNITED STATES PATENT OFFICE.

JOHN ORMEROD, OF NEW YORK, N. Y.

SYRUP-JAR.

SPECIFICATION forming part of Letters Patent No. 626,085, dated May 30, 1899.

Application filed March 7, 1899. Serial No. 708,151. (No model.)

To all whom it may concern:

Be it known that I, JOHN ORMEROD, of the city of New York, borough of Brooklyn, in the county of Kings and State of New York, have invented a new and useful Improvement in Syrup-Jars, of which the following is a full, clear, and exact description.

The object of my invention is to provide a pivoted or drop syrup-jar especially adapted for use in connection with soda-water fountains and syrup racks, cases, and the like.

A further object of the invention is to provide a means whereby the jars may be pivoted at their faucets and moved inward and outward with the least possible exertion and whereby the center of gravity is such that when the jars are in an upright position they will not be liable to drop to an inclined position and whereby when the jars are inclined sufficiently to receive the supply of liquid they will not exert undue tension upon the check devices employed.

Another object of the invention is to provide a jar of the character above set forth that may be placed in a series, one immediately adjoining the other, the series of jars when set up presenting a series of panels that may be ornamental or plain.

The invention consists in the novel construction and combination of the several parts, as will be hereinafter fully set forth, and pointed out in the claims.

Reference is to be had to the accompanying drawings, forming a part of this specification, in which similar characters of reference indicate corresponding parts in all the figures.

Figure 1 is a vertical section through the front upper portion of a soda-water box and a side elevation of an improved jar applied thereto, the jar being in its normal or vertical position. Fig. 2 is a view similar to Fig. 1, the jar being in an inclined position or a position to receive liquid. Fig. 3 is a horizontal section taken substantially on the line 3 3 of Fig. 1, and Fig. 4 is a horizontal section taken substantially on the line 4 4 of Fig. 1.

A represents the front wall of a soda-water box, B the cornice of the box, and C the tumbler-back, said tumbler-back being spaced from the front wall A by suitable braces 10, as shown in Figs. 1 and 2.

D represents a syrup-jar, which may be

made of any desired material and of any dimensions, the top of the jar being open, and E represents a panel secured to the front of the jar; extending, preferably, to a point below the jar, and said panel E is of greater width than the width of the jar in order that the side portions of the panel may extend beyond the side portions of the jar, as shown in Fig. 4. When the improved jars are used with the form of the soda-water box illustrated, the jars are located between the upper edge of the tumbler-back and the lower surface of the cornice, and said jars are placed so close together that the side edges of the panels E are practically in engagement. The space between the panels is sufficient only to permit the boxes to be independently drawn outward.

A bracket F is provided for each of the jars, said brackets being so located that they will be beneath the jars, and said brackets are attached to the tumbler-board C. Each bracket preferably consists of a horizontal U-shaped body 10^a, provided with open bearings 11 in the upper edge of each member, near the outer end of said members, as shown particularly in Figs. 1, 2, and 3. The body of each bracket is provided with a shank 12, that extends through the tumbler-back, and the inner end of the shank is fitted to receive a suitable nut and washer 13, as shown in Fig. 3.

Each jar D is provided with a dispensing-faucet 14 of any desired construction, but each dispensing-faucet is provided at each side with a trunnion 15, and when the syrup-jar is in position the trunnions of its dispensing-faucet enter and are arranged to turn in the open bearings of the bracket F provided for said jar.

Preferably near the top of each jar, at one side of the center of each side of said jar, a button 16 is secured. The button does not extend out from the side surface of the jar as far as the projecting side portions of the panel attached to the jar. A bail G is provided for each set of jars, and each bail preferably consists of a rear cross-bar 17, having an eye 18 formed therein, and side members 19, forwardly projected from the cross-bar. These side members, as shown in Figs. 1 and 2, are preferably slightly curved and each terminates at its forward end in a hook 20,

the hooks being adapted to receive the buttons 16. The bails are pivotally attached to the under surface of the cornice B through the medium of an eye 21 or the equivalent thereof.

In operation, the bails having been connected with the syrup-jars, when a jar is to be filled or supplied with material it is drawn outward to the position shown in Fig. 2, its outward movement being limited by the length of the side members of the bail, the trunnions 15 constituting the pivots for the jar and the bracket F the bearing for the trunnions.

When the jar is in its outer inclined position, but little strain is brought to bear on the bail, since the center of gravity is so calculated as to produce such result, and the same gravity-line causes the jar when in its normal or vertical position to remain securely therein. A knob 21^a is preferably located upon the panel of each jar, near the upper end of said panel, to facilitate the manipulation of the jar. When it is desired to entirely remove the jar from its support, said jar is carried a sufficient distance outward to permit its bail to be disconnected from the buttons 16, whereupon the jar may be lifted from its support, readily cleaned, and expeditiously and conveniently replaced.

Having thus described my invention, I claim as new and desire to secure by Letters Patent—

1. A faucet provided with trunnions, bearings for the trunnions, and means for securing the bearings to a support, as described.

2. A faucet provided with trunnions, and a U-shaped bracket provided with open bearings adapted to receive said trunnions, said faucet being contained between the members of the bracket, as described.

3. The combination, with a syrup-jar and its faucet, of trunnions projected from opposite sides of the faucet, and a U-shaped bracket adapted to receive the faucet between its members, each of said members of the bracket having a bearing therein, arranged to receive a trunnion of said faucet, as set forth.

4. The combination, with a syrup-jar and its dispensing-faucet, of a trunnion projected from opposite sides of said faucet, a bracket provided with bearings to receive said trunnions, and a check device for the syrup-jar, adapted to limit the outward movement of said jar, as described.

5. The combination, with a syrup-jar, a dispensing-faucet for said jar, trunnions projected from opposite sides of said dispensing-faucet, and buttons located on said jar, of a U-bracket having open bearings to receive the trunnions of the dispensing-faucet, said bracket being arranged for attachment to a support, and a bail likewise adapted for attachment to a support, the bail having detachable and sliding connection with said buttons on the jar, as described.

JOHN ORMEROD.

Witnesses:

M. DPEKTORSKY,
B. GOLDSTEIN.