

R. C. MORRIS.
 FORM OR MOLD FOR CONCRETE RECEPTACLES.
 APPLICATION FILED AUG. 20, 1908.

939,059.

Patented Nov. 2, 1909.
 2 SHEETS—SHEET 1.

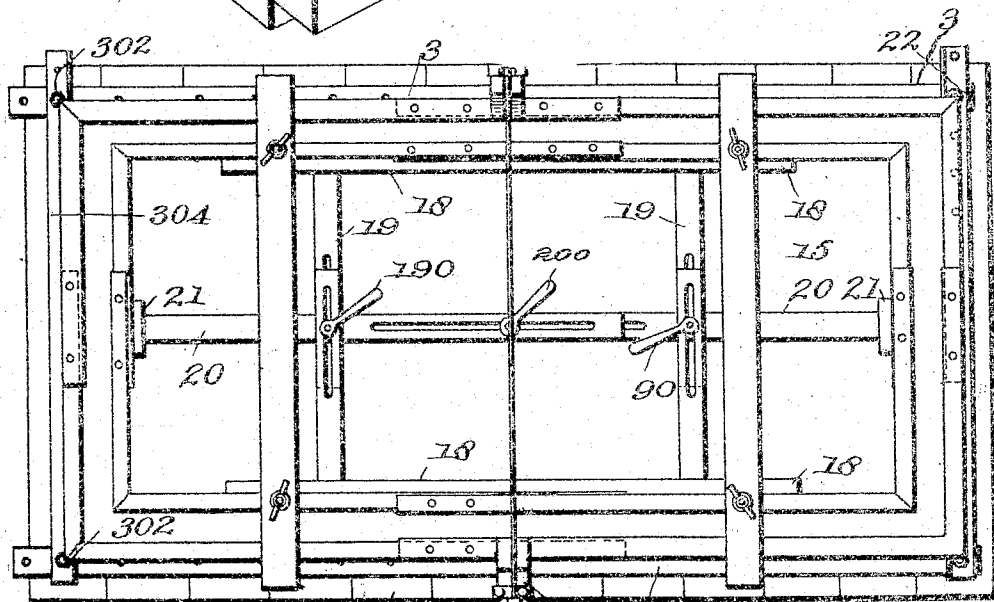
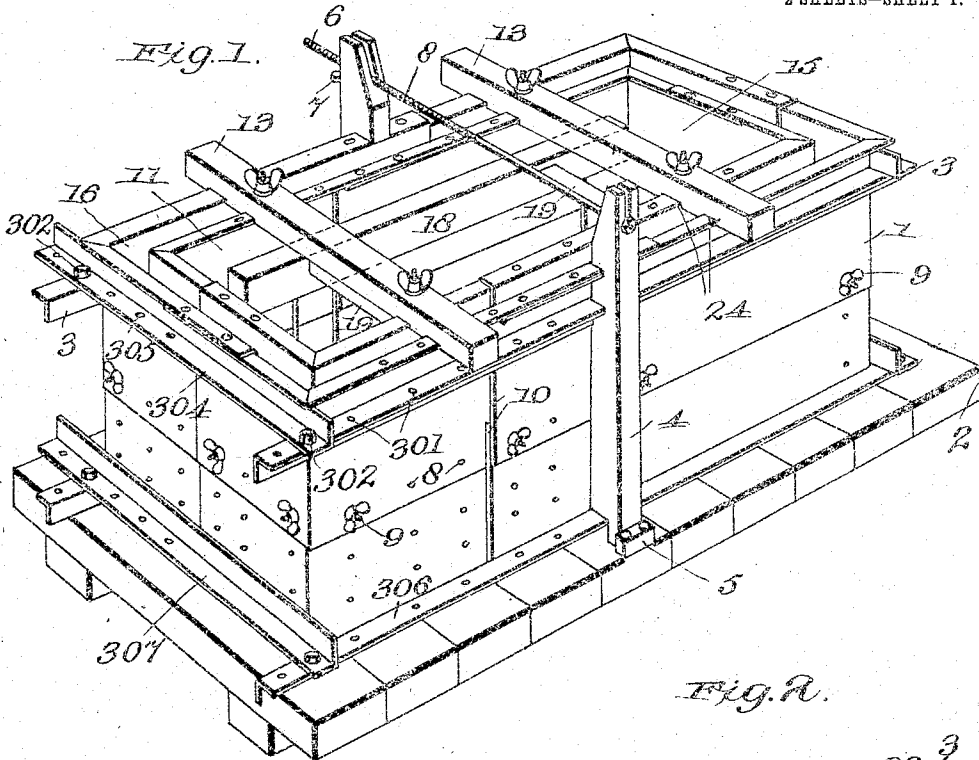

Witnesses
Wm. M. Dural
Geo. A. Byrnes

Inventor
R. C. Morris by
Wilkinson Fisher &
Wichers
 Attorney

R. C. MORRIS.
 FORM OR MOLD FOR CONCRETE RECEPTACLES.
 APPLICATION FILED AUG. 20, 1908.

939,059.

Patented Nov. 2, 1909.

2 SHEETS—SHEET 2.

Fig. 3.

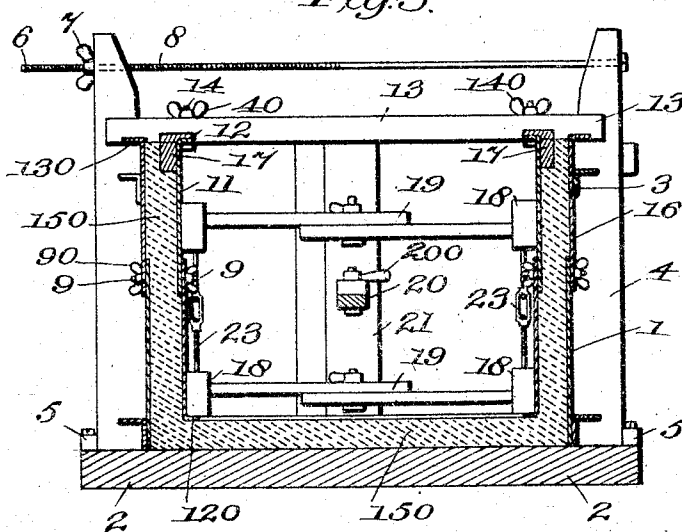

Fig. 4.

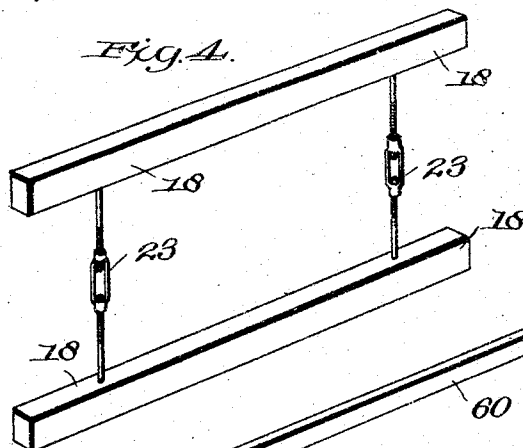

Fig. 5.

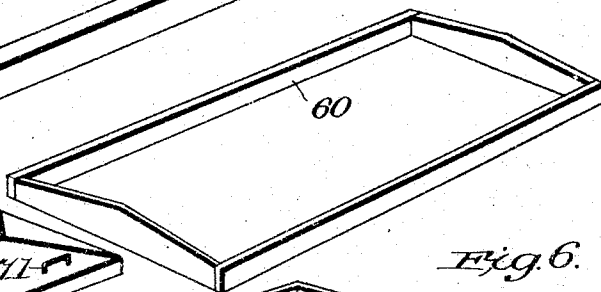

Fig. 7.

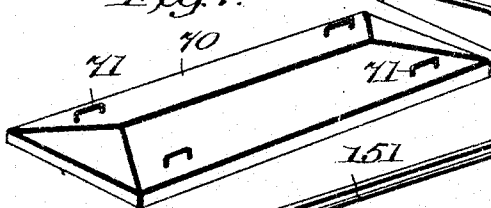
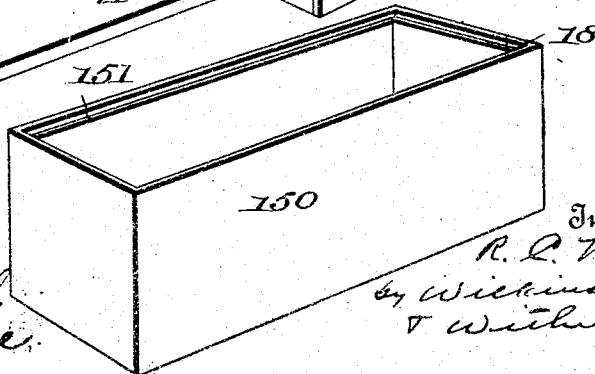

Fig. 6.



Witnesses
W. M. Durrill
Geo. H. Bogue

Inventor
R. C. Morris
 by *Wilkinson Fisher*
 & *Witherspoon*
 Attorneys

UNITED STATES PATENT OFFICE.

ROBERT C. MORRIS, OF LOUISVILLE, KENTUCKY, ASSIGNOR OF ONE-FOURTH TO GEORGE C. TERRY AND ONE-FOURTH TO CHANCEY O. TICE, OF LOUISVILLE, KENTUCKY.

FORM OR MOLD FOR CONCRETE RECEPTACLES.

939,059.

Specification of Letters Patent.

Patented Nov. 2, 1909.

Application filed August 20, 1908. Serial No. 449,522.

To all whom it may concern:

Be it known that I, ROBERT C. MORRIS, a citizen of the United States, residing at Louisville, in the county of Jefferson and State of Kentucky, have invented certain new and useful Improvements in Forms or Molds for Concrete Receptacles; and I do hereby declare the following to be a full, clear, and exact description of the invention, such as will enable others skilled in the art to which it appertains to make and use the same.

This invention relates to forms or molds for making concrete receptacles such as burial vaults, water tanks etc., and the object of this invention is to provide such forms or molds in sections of such a nature as can be conveniently assembled and disassembled in the operation of forming the concrete product, and of such a nature as to permit the ready removal of the forms from both the outside and inside of the product after it is formed.

To these ends my invention consists in the details of construction and combination of parts more fully hereinafter disclosed and particularly pointed out in the claims.

Referring to the accompanying drawings which are made a part of this specification and in which similar numerals of reference indicate similar parts in all the views:— Figure 1, is a perspective view of the completed form or mold when assembled. Fig. 2, is a top plan view of the same. Fig. 3, is a transverse vertical section of the form in operation. Fig. 4, shows the details of the interior side braces of the inside form. Fig. 5, shows the form or mold for the cover of the receptacle. Fig. 6, the completed receptacle or burial vault; and Fig. 7, shows the completed cover for the same.

1 represents the outside plates of the form or mold, which are in eight pieces to allow them to collapse or expand in three dimensions; 2 the bottom upon which the receptacle is formed; and 3 longitudinal supporting bars, preferably made of angle irons for supporting the plates 1, against outward pressure. These bars 3 are provided with the holes 301, for receiving the bolts 302, passing through said bars 3; and the end supporting bars 304, are also provided with the holes 305, adapted to register with said holes 302, when the form is collapsed or expanded. Similar perforated longitudinal

supporting bars of angle iron 306 are provided at or near the bottom of the form, and similar perforated end supporting bars 307 are also provided to cooperate therewith.

Rising from the bottom 2, at or about the middle of the sides 1, are the vertical standards or uprights 4, through which pass said longitudinal bars 3 and 306, as shown; the bottom is further provided with lugs 5, to hold said uprights in place. Passing through the upper ends of said uprights is the screw threaded rod 6, provided with the nut 7, taking against one of said uprights, and serving to adjustably hold all the parts together, as will be readily understood.

The various parts of the outer side plates 1, are provided with numerous holes 8, through which pass the bolts 9, provided with the wing nuts 90. Said holes, bolts and nuts permit the securing of the form or mold after it has been expanded or contracted in any direction. The ends 10 of the plates are suitably overlapped, as shown, to permit of such change in dimensions.

The inside plates 11 of the mold or form are similar in construction to the outside plates, and are preferably made of thin steel material, so that they may be light enough to be readily handled by hand; and are also provided with the top flanges 12 and bottom flanges 120 in order to strengthen and stiffen the same. 13 represents cross bars, which rest upon the top flanges 130 of the outer plates 1, and serve to support the inner plates 11 by means of the bolts 14 which pass through said cross bars and flanges 12, and which are provided with the wing nuts 140.

In order to hold the inner plates in position, I provide the two upper and two lower strips 18, connected by the turn buckles 23 as best shown in Figs. 3 and 4; and between these strips 18 extend the adjustable brace bars or spreaders 19, as shown in Figs. 2 and 3. These bars 19 may be suitably slotted, as shown, and provided with the adjustable securing means 190.

20 represents similar adjustable slotted, supporting brace bars extending between the inside ends of the mold, and similarly provided with an adjustable securing means 200; while 21 represents vertical end strips, against which the ends of said supporting bars 20 take as shown.

Between the outside plates 1, and the in-

side plates 11 of the mold is formed the mold cavity, in which the concrete material 150 is placed. The lower inside plates 11 are so adjusted by means of the bolts 9, that their flanges 120 rest a distance above the floor 2, equal to the thickness it is desired to give to the bottom of the concrete vault or receptacle, the whole inside being supported by the cross beams 13, as above described. When the concrete is poured in through the open top 15 of the mold, it is allowed to rise until it reaches these flanges 120, when the concrete is then poured into the mold cavity between the inner and outer plates, until it reaches nearly to the top of said cavity. By the time the mold cavity is thus formed, the bottom may be struck off, or leveled, using the flanges 120 as guides to determine the final thickness of said bottom. After this is done, the concrete will be sufficiently solid to support the side plates 11 and to permit the removal of the supporting beams 13.

The rabbet forming strips 17 may now be placed in the mold cavity, and the concrete filled up to the top of the latter and smoothed off; or these strips may be placed in said cavity at any earlier stage and suitably supported from the outside. When the strips 17 are removed a rabbet 151 will be formed in the finished receptacle 150, as shown in Fig. 6, which latter is obtained by disassembling the parts of the mold after the concrete has sufficiently hardened.

The operation of the form or mold will be clear from the above, but it may be summed up as follows:—When it is desired to assemble the mold, the floor 2, if a floor is to be used, is first brought into position; the outer and inner plates are so adjusted the one over the other as to form a mold cavity having any desired inside and outside dimensions and said plates are firmly secured together by means of the bolts 9; the longitudinal upper and lower outside supporting bars are brought into position, and the outside end bars are secured thereto by means of the bolts 302 passing through the proper holes in said bars. The uprights 4 are secured over said outside bars after the inside plates have been brought into position inside said outside plates. The inside strips 18 and 21 and the adjustable spreaders 19 and 20 are brought into place, and the whole inside wall of the mold cavity suspended by the cross bars 13, as above described.

The flanges 12, 120 and 130 are important features of this invention, for they serve to stiffen the plates as above stated, and thereby permit them to be made so light that they can for ordinary burial vaults be handled by one man by hand. And the flanges 120, are an additional especially important feature of this invention, for not only do they secure the necessary strength

above described, but they support the plates on the concrete while it sets, and constitute a convenient and ready gage by which the workman may at once know the thickness of the bottom of the vault and may level it off without any delay whatever.

After the vault is formed in the manner above set forth, the form or mold 60, shown in Fig. 5, may be used to form the finished cover 70, shown in Fig. 7, which is preferably provided with the handles 71 before the concrete sets.

Various changes coming within the spirit of this invention will readily suggest themselves to those skilled in the art, and therefore I do not wish to be limited to the exact details of construction, except as specified in the claims.

What I claim is:—

1. In a form or mold for concrete receptacles, the combination of telescoping inner and outer side and end walls flanged at their top edges and provided with registering holes; telescoping upper and lower outer side and end supporting bars, also, provided with registering holes; two pairs of horizontal supporting strips 18 adapted to rest on the inside of said inner walls; and adjustable spreader bars 19 adapted to extend between said strips, substantially as described.

2. In a form or mold for concrete receptacles, the combination of telescoping inner and outer side and end walls flanged at their top edges and provided with registering holes, and bolts adapted to secure said sides together; telescoping upper and lower outer side and end supporting bars, also provided with registering holes; two pairs of horizontal supporting strips 18 and one pair of vertical strips 21 adapted to rest on the inside of said inner walls; and adjustable spreader bars 19 and 20 adapted to extend between said strips, substantially as described.

3. In a form or mold for concrete receptacles, the combination of perforated inner and outer adjustable telescoping plates provided with stiffening flanges at the upper edges; means comprising bolts for holding said plates in their adjusted positions; cross bars 13 extending across and resting on the upper flanges of said outer plates; and bolts passing through said bars and the flanges of said inner plates and serving to support the same above the bottoms of said outer plates, substantially as described.

4. In a form or mold for concrete receptacles, the combination of inner adjustable telescoping plates provided with registering holes and flanges on their top and bottom edges; outer plates also provided with registering holes and flanges on their top edges; cross beams adapted to rest on said latter flanges; means passing through said beams adapted to hold the bottom flanges of said

inner plates a predetermined distance above the bottom edges of the outer plates; and adjustable spreaders inside said inner plates, substantially as described.

5 5. In a form or mold for concrete receptacles, the combination of inner adjustable telescoping plates provided with registering holes and flanges on their top and bottom edges; outer plates also provided with registering holes and flanges on their top edges; 10 cross beams adapted to rest on said latter flanges; means passing through said beams adapted to hold the bottom flanges of said inner plates a predetermined distance above 15 the bottom edges of the outer plates; horizontal strips 18, and vertical strips 21 adapted to contact with said inner plates; and adjustable spreaders inside said inner plates adapted to contact with said strips, substantially 20 as described.

6. In a form or mold for concrete receptacles, the combination of inner and outer adjustable telescoping plates provided with stiffening flanges at their upper edges, and 25 said inner plates provided with stiffening flanges at their lower edges; a bottom for said mold; cross beams 13 adapted to rest on the upper flanges of said outer plates and provided with means whereby the lower 30 flanges of said inner plates are supported a predetermined distance above said bottom; and inner and outer means for holding said plates in position, substantially as described.

7. In a form or mold for concrete receptacles, the combination of inner and outer adjustable telescoping plates provided with registering holes, stiffening flanges at their upper edges and said inner plates provided with stiffening flanges at their lower edges;

a bottom for said mold; cross beams 13 provided with recesses fitting and adapted to rest on the upper flanges of said outer plates and provided with means whereby the lower flanges of said inner plates are supported a predetermined distance above said bottom; 40 and inner and outer means for holding said plates in position, comprising supporting bars on the outside of said mold and spreader bars on the inside of the same, substantially 45 as described.

8. In a form or mold for concrete receptacles, the combination of inner plates flanged at their bottom edges; outer adjustable telescoping plates flanged at their upper edges and provided with registering holes; bolts 50 passing through said holes adapted to hold said plates in their adjusted positions; outer, upper and lower supporting side and end bars also provided with registering holes; a bottom for said mold; vertical braces 4 60 through which said supporting side plates pass; an adjustable rod passing through said vertical braces; cross bars provided with recesses fitting the flanges of said outer plates and provided with means for holding the 65 flanges of said inner plates a predetermined distance above said bottom; two pairs of horizontal strips 18 fitting the inside of said inner plates; and vertical strips 21, also, fitting the inside of said inner plates; and 70 adjustable spreaders contacting with said strips, substantially as described.

In testimony whereof, I affix my signature, in presence of two witnesses.

ROBT. C. MORRIS.

Witnesses:

W. MAX. DUVALL,
T. A. WITHERSPOON.